

TECHNICAL MANUAL

UNIT MAINTENANCE MANUAL

FOR
CARRIER, PERSONNEL, FULL TRACKED, ARMORED M113A3
2350-01-219-7577 (EIC AEY)

CARRIER, COMMAND POST, LIGHT TRACKED M577A3
2350-01-369-6085 (EIC AE7)

CARRIER, SMOKE GENERATOR, FULL TRACKED M1059A3
2350-01-369-6083 (EIC AFA)

CARRIER, MORTAR, 120-MM M121, SELF-PROPELLED M1064A3
2350-01-369-6082 (EIC AE8)

CARRIER, STANDARDIZED INTEGRATED COMMAND POST SYSTEM
(SICPS) M1068A3
2350-01-369-6086 (EIC AFC)

CARRIER, MECHANIZED SMOKE OBSCURANT M58
2350-01-418-6654 (EIC 5CG)

SUPERSEDURE NOTICE — This manual supersedes TM 9-2350-277-20 dated 24 July 1994, including all changes.

DISTRIBUTION STATEMENT A — Approved for public release; distribution is unlimited.

HEADQUARTERS, DEPARTMENT OF THE ARMY

January 2001

CHANGE
NO. 3

HEADQUARTERS DEPARTMENT OF THE ARMY
WASHINGTON, D.C., 27 April 2004

TECHNICAL MANUAL

UNIT MAINTENANCE MANUAL

FOR

CARRIER, PERSONNEL, FULL TRACKED, ARMORED M113A3
2350-01-219-7577 (EIC AEY)

CARRIER, COMMAND POST, LIGHT TRACKED M577A3
2350-01-369-6085 (EIC AE7)

CARRIER, SMOKE GENERATOR, FULL TRACKED M1059A3
2350-01-369-6083 (EIC AFA)

CARRIER, MORTAR, 120-MM M121, SELF-PROPELLED M1064A3
2350-01-369-6082 (EIC AE8)

CARRIER, STANDARDIZED INTEGRATED COMMAND POST SYSTEM (SICPS) M1068A3
2350-01-369-6086 (EIC AFC)

CARRIER, MECHANIZED SMOKE OBSCURANT M58
2350-01-418-6654 (EIC 5CG)

DISTRIBUTION STATEMENT A – Approved for public release; distribution is unlimited.

TM 9-2350-277-20-3, 2 January 2001 is updated as follows:

1. File this change sheet in front of the publication for reference purposes.
2. New or updated text is indicated by a vertical bar in the outer margin of the page.
3. Revised illustrations are indicated by a miniature pointing hand adjacent to the updated area.
4. Remove old pages/Work Packages and insert new pages/Work Packages as indicated below.

Remove Pages/Work Packages

A/B blank
WP 0328 00
WP 0361 00
WP 0403 00
Index 17 – Index 28
Index 53 – Index 54
Index 93 – Index 94
Index 99 – Index 102

Insert Pages/Work Packages

A/B blank
WP 0328 00
WP 0361 00
WP 0403 00
Index 17 – Index 28
Index 53 – Index 54
Index 93 – Index 94
Index 99 – Index 102

By Order of the Secretary of the Army:

Official:

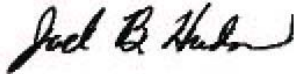

JOEL B. HUDSON
*Administrative Assistant to the
Secretary of the Army*
0405805

PETER J. SCHOOMAKER
*General, United States Army
Chief of Staff*

DISTRIBUTION:

To be distributed in accordance with the initial distribution number (IDN) 371205 requirements for TM 9-2350-277-20-3.

CHANGE
NO. 2

HEADQUARTERS
DEPARTMENT OF THE ARMY
WASHINGTON, D.C. 02 OCTOBER 2003

**TECHNICAL MANUAL
UNIT MAINTENANCE MANUAL
FOR**

**CARRIER, PERSONNEL, FULL TRACKED, ARMORED M113A3
2350-01-219-7577 (EIC AEY)**

**CARRIER, COMMAND POST, LIGHT TRACKED M577A3
2350-01-369-6085 (EIC AE7)**

**CARRIER, SMOKE GENERATOR, FULL TRACKED M1059A3
2350-01-369-6083 (EIC AFA)**

**CARRIER, MORTAR, 120-MM M121, SELF-PROPELLED M1064A3
2350-01-369-6082 (EIC AE8)**

**CARRIER, STANDARDIZED INTEGRATED COMMAND POST SYSTEM (SICPS) M1068A3
2350-01-369-6086 (EIC AFC)**

**CARRIER, MECHANIZED SMOKE OBSCURANT M58
2350-01-418-6654 (EIC 5CG)**

DISTRIBUTION STATEMENT A – Approved for public release; distribution is unlimited.

TM 9-2350-277-20-3, 2 January 2001 is updated as follows:

1. File this change sheet in front of the publication for reference purposes.
2. New or updated text is indicated by a vertical bar in the outer margin of the page.
3. Revised illustrations are indicated by a miniature pointing hand adjacent to the updated area.
4. Remove old pages/Work Packages and insert new pages/Work Packages as indicated below.

Remove Pages/Work Packages

Title

A/B

i-xxx

Chapter 8 WP Index

WP 0260 00

WP 0262 00

WP 0263 00

WP 0264 00

WP 0265 00

WP 0266 00

WP 0268 00

WP 0269 00

WP 0270 00

WP 0272 00

WP 0273 00

WP 0274 00

WP 0275 00

WP 0289 00

WP 0296 00

WP 0298 00

WP 0319 00

None

WP 0337 00

WP 0339 00

WP 0340 00

WP 0342 00

WP 0346 00

WP 0348 00

WP 0350 00

WP 0355 00

WP 0356 00

None

WP 0362 00

WP 0366 00

WP 0369 00

WP 0371 00

WP 0372 00

WP 0379 00

Index

Cover

Insert Pages/Work Packages

Title

A/B

i-vii/viii blank

Chapter 8 WP Index

WP 0260 00

WP 0262 00

WP 0263 00

WP 0264 00

WP 0265 00

WP 0266 00

WP 0268 00

WP 0269 00

WP 0270 00

None

None

None

WP 0275 00

WP 0289 00

WP 0296 00

WP 0298 00

None

WP 0321 01

WP 0337 00

None

WP 0340 00

None

WP 0346 00

WP 0348 00

WP 0350 00

WP 0355 00

WP 0356 00

WP 0359 01

WP 0362 00

WP 0366 00

WP 0369 00

None

None

WP 0379 00

Index

Cover

PETER J. SCHOOMAKER
General, United States Army
Chief of Staff

Official:



JOEL B. HUDSON

Administrative Assistant to the
Secretary of the Army
0133207

DISTRIBUTION:

To be distributed in accordance with the initial distribution number (IDN) 371205 requirements for TM 9-2350-277-20-3.

**TECHNICAL MANUAL
UNIT MAINTENANCE MANUAL
FOR**

**CARRIER, PERSONNEL, FULL TRACKED, ARMORED M113A3
2350-01-219-7577 (EIC AEY)**

**CARRIER, COMMAND POST, LIGHT TRACKED M577A3
2350-01-369-6085 (EIC AE7)**

**CARRIER, ANTI-TANK (TOW), FULL TRACKED, ARMORED M901A3
2350-01-369-7253 (EIC AFD)**

**CARRIER, FIRE SUPPORT PERSONNEL, FULL TRACKED, ARMORED M981A3
2350-01-369-6079 (EIC AFB)**

**CARRIER, SMOKE GENERATOR, FULL TRACKED M1059A3
2350-01-369-6083 (EIC AFA)**

**CARRIER, MORTAR, 120-MM M121, SELF-PROPELLED M1064A3
2350-01-369-6082 (EIC AE8)**

**CARRIER, STANDARDIZED INTEGRATED COMMAND POST SYSTEM (SICPS) M1068A3
2350-01-369-6086 (EIC AFC)**

**CARRIER, MECHANIZED SMOKE OBSCURANT M58
2350-01-418-6654 (EIC 5CG)**

DISTRIBUTION STATEMENT A – Approved for public release; distribution is unlimited.

TM 9-2350-277-20-3, 2 January 2001 is updated as follows:

1. File this change sheet in front of the publication for reference purposes.
2. New or updated text is indicated by a vertical bar in the outer margin of the page.
3. Revised illustrations are indicated by a miniature pointing hand adjacent to the updated area.
4. Remove old pages/Work Packages and insert new pages/Work Packages as indicated below.

Remove Pages/Work Packages

A/B
i-xxix/xxx blank
Chapter 8 WP Index
WP 0269 00
WP 0279 00
NEW
WP 0287 00
WP 0288 00
WP 0289 00
WP 0290 00
WP 0291 00
WP 0292 00
WP 0293 00
NEW
WP 0294 00
NEW
WP 0295 00
NEW
WP 0328 00
WP 0330 00
WP 0337 00
WP 0349 00
WP 0351 00
WP 0361 00
WP 0362 00
WP 0363 00
WP 0365 00
WP 0367 00
NEW
WP 0369 00
WP 0371 00
WP 0391 00
Index

Insert Pages/Work Packages

A/B
i-xxx
Chapter 8 WP Index
WP 0269 00
WP 0279 00
WP 0279 01
WP 0287 00
WP 0288 00
WP 0289 00
WP 0290 00
WP 0291 00
WP 0292 00
WP 0293 00
WP 0293 01
WP 0294 00
WP 0294 01
WP 0295 00
WP 0295 01
WP 0328 00
WP 0330 00
WP 0337 00
WP 0349 00
WP 0351 00
WP 0361 00
WP 0362 00
WP 0363 00
WP 0365 00
WP 0367 00
WP 0367 01
WP 0369 00
WP 0371 00
WP 0391 00
Index

Official:



JOEL B. HUDSON

*Administrative Assistant to the
Secretary of the Army*
0133207

PETER J. SCHOOMAKER
*General, United States Army
Chief of Staff*

DISTRIBUTION:

To be distributed in accordance with the initial distribution number (IDN) 371205 requirements for TM 9-2350-277-20-3.

INSERT LATEST UPDATED PAGES/WORK PACKAGES. DESTROY SUPERSEDED DATA.

LIST OF EFFECTIVE PAGES/WORK PACKAGES

Note: Updates to all portions of this TM are indicated by a vertical bar in the outer margin of the page.

Dates of issue for original and updated pages/work packages are:

- Original 0 (2 January 2001)
- Change 1 (5 September 2003)
- Change 2 (2 October 2003)
- Change 3 (27 April 2004)

TOTAL NUMBER OF PAGES FOR FRONT AND REAR MATTER IS 156 AND TOTAL NUMBER OF WORK PACKAGES IS 158 CONSISTING OF THE FOLLOWING:

Page/WP No.	*Change No.	Page/WP No.	*Change No.	Page/WP No.	*Change No.
Cover	2	WP 0346 00	2	Index 29 – Index 52	2
A/B blank	3	WP 0347 00	0	Index 53 – Index 54	3
i – vii/viii blank	2	WP 0348 00	2	Index 55 – Index 92	2
Chapter 8 WP Index	2	WP 0349 00	1	Index 93 – Index 94	3
WP 0252 00 – 0259 00	0	WP 0350 00	2	Index 95 – Index 98	2
WP 0260 00	2	WP 0351 00	1	Index 99 – Index 102	3
WP 0261 00	0	WP 0352 00 – 0354 00	0	Index 103/104 blank	2
WP 0262 00 – 0266 00	2	WP 0355 00 – 0356 00	2	DA 2028 Sample/Reverse	0
WP 0267 00	0	WP 0357 00 – 0359 00	0	DA 2028/Reverse (3)	0
WP 0268 00 – 0270 00	2	WP 0359 01 (Added)	2	Authentication Page	0
WP 0271 00	0	WP 0360 00	0	Metric Chart	0
WP 0272 00 – 0274 00 (Deleted)	2	WP 0361 00	3	Back Cover	0
WP 0275 00	2	WP 0362 00	2		
WP 0276 00 – 0277 00	0	WP 0363 00	1		
WP 0278 00	0	WP 0364 00	0		
WP 0279 00 – 0279 01	1	WP 0365 00	1		
WP 0280 00 – 0286 00	0	WP 0366 00	2		
WP 0287 00 – 0288 00	1	WP 0367 00 – 0367 01	1		
WP 0289 00	2	WP 0368 00	0		
WP 0290 00 – 0295 01	1	WP 0369 00	2		
WP 0296 00	2	WP 0370 00	0		
WP 0297 00	0	WP 0371 00 – 0372 00 (Deleted)	2		
WP 0298 00	2	WP 0373 00 – 0378 00	0		
WP 0299 00 – 0318 00	0	WP 0379 00	2		
WP 0319 00 (Deleted)	2	WP 0380 00 – 0383 00	0		
WP 0320 00 – 0321 00	0	Chapter 9 WP Index	1		
WP 0321 01 (Added)	2	WP 0384 00 – 0390 00	0		
WP 0322 00 – 0327 00	0	WP 0391 00	1		
WP 0328 00	3	WP 0392 00 – 0401 00	0		
WP 0329 00	0	Chapter 10 WP Index	0		
WP 0330 00	1	WP 0402 00	0		
WP 0331 00 – 0336 00	0	WP 0403 00	3		
WP 0337 00	2	WP 0404 00	0		
WP 0338 00	0	Chapter 11 WP Index	0		
WP 0339 00 (Deleted)	2	WP 0405 00	0		
WP 0340 00	2	Chapter 12 WP Index	0		
WP 0341 00	0	WP 0406 00 – 0412 00	0		
WP 0342 00 (Deleted)	2	Index 1 – Index 16	2		
WP 0343 00 – 0345 00	0	Index 17 – Index 28	3		

*Zero in this column indicates an original page

HEADQUARTERS
DEPARTMENT OF THE ARMY
WASHINGTON, D.C. 02 JANUARY 2001

TECHNICAL MANUAL**UNIT MAINTENANCE MANUAL****FOR**

CARRIER, PERSONNEL, FULL TRACKED, ARMORED M113A3
NSN 2350-01-219-7577
(EIC AEY)

CARRIER, COMMAND POST, LIGHT TRACKED M577A3
NSN 2350-01-369-6085
(EIC AE7)

CARRIER, SMOKE GENERATOR, FULL TRACKED M1059A3
NSN 2350-01-369-6083
(EIC AFA)

CARRIER, MORTAR, 120-MM M121, SELF-PROPELLED M1064A3
NSN 2350-01-369-6082
(EIC AE8)

CARRIER, STANDARDIZED INTEGRATED COMMAND POST SYSTEM (SICPS) M1068A3
NSN 2350-01-369-6086
(EIC AFC)

CARRIER, MECHANIZED SMOKE OBSCURANT M58
NSN 2350-01-418-6654
(EIC 5CG)

REPORTING ERRORS AND RECOMMENDING IMPROVEMENTS

You can help improve this publication. If you find any mistakes or if you know of a way to improve the procedures, please let us know. Submit your DA Form 2028-2 (Recommended Changes to Equipment Technical Publications), through the Internet, on the Army Electronic Product Support (AEPS) website. The internet address is <http://aeeps.ria.army.mil>. If you need a password, scroll down and click on "ACCESS REQUEST FORM". The DA 2028 is located in the ONLINE FORMS PROCESSING section of the AEPS. Fill out the form and click on SUBMIT. Using this form on the AEPS will enable us to respond quicker to your comments and better manage the DA Form 2028 program. You may also mail, fax, or E-mail your letter, DA Form 2028 or DA Form 2028-2 direct to: Technical Publication Information Office, TACOM-RI, 1 Rock Island Arsenal, Rock Island, IL 61299-7630. The email address is TACOM-TECH-PUBS@ria.army.mil. The fax number is DSN 793-0726 or Commercial (309)782-0726.

SUPERSEDURE NOTICE — This manual supersedes TM 9-2350-277-20 dated 24 July 1994, including all changes.

DISTRIBUTION STATEMENT A — Approved for public release; distribution is unlimited.

TABLE OF CONTENTS

WP Sequence No.

Volume 3

CHAPTER 8 —UNIT MAINTENANCE INSTRUCTIONS FOR ELECTRICAL SYSTEM

ADJUST GENERATOR DRIVE BELT	0252 00
REPLACE GENERATOR DRIVE BELT	0253 00
REPLACE GENERATOR TURNBUCKLE PARTS	0254 00
REPLACE GENERATOR/BRACKET	0255 00
ADJUST VOLTAGE REGULATOR	0256 00
REPLACE REGULATOR ASSEMBLY	0257 00
REPLACE STARTER RELAY SWITCH	0258 00
REPLACE STARTER	0259 00
REPLACE MASTER SWITCH PANEL ASSEMBLY (M113A3, M1059A3, M1064A3, AND M58 ONLY)	0260 00
REPLACE MASTER SWITCH PANEL ASSEMBLY (M577A3 AND M1068A3 ONLY)	0261 00
REPLACE MASTER SWITCH (M113A3, M1059A3, M1064A3, AND M58 ONLY).....	0262 00
REPLACE AUXILIARY POWER (SLAVE) RECEPTACLE (M113A3, M1059A3, M1064A3, AND M58 ONLY).....	0263 00
REPLACE NATO AUXILIARY POWER (SLAVE) RECEPTACLE (M577A3 AND M1068A3 ONLY).....	0264 00
REPLACE UTILITY OUTLET RECEPTACLE	0265 00
REPLACE MASTER SWITCH TO DISTRIBUTION BOX LEAD (CIRCUIT 49) (M113A3, M1059A3, M1064A3, AND M58 ONLY)	0266 00
REPLACE MASTER SWITCH TO DISTRIBUTION BOX LEAD (CIRCUIT 49) (M577A3 AND M1068A3 ONLY)	0267 00
REPLACE MASTER SWITCH TO AUXILIARY POWER RECEPTACLE LEAD (CIRCUIT 50) (M113A3, M1059A3, M1064A3, AND M58)	0268 00
REPLACE DISTRIBUTION BOX (M113A3, M1059A3, M1064A3, AND M58 ONLY)	0269 00
REPAIR DISTRIBUTION BOX (M113A3, M1059A3, M1064A3, AND M58 ONLY).....	0270 00
REPLACE DISTRIBUTION BOX ASSEMBLY (M577A3 AND M1068A3 ONLY)	0271 00
DELETED	0272 00
DELETED	0273 00
DELETED	0274 00
REPLACE BILGE PUMP CIRCUIT BREAKERS	0275 00

TABLE OF CONTENTS (cont)

	<u>WP Sequence No.</u>
REPLACE REAR UTILITY RECEPTACLE CIRCUIT BREAKERS (M577A3 AND M1068A3 ONLY)	0276 00
REPLACE FUEL SELECTOR SWITCH (M577A3 AND M1068A3 ONLY)	0277 00
REPLACE BLOWER SWITCH (M577A3 AND M1068A3 ONLY).....	0278 00
REPLACE INSTRUMENT PANEL ASSEMBLY (ALL EXCEPT M58)	0279 00
REPLACE INSTRUMENT PANEL ASSEMBLY (M58 ONLY).....	0279 01
REPLACE CIRCUIT BREAKER.....	0280 00
REPLACE FUEL SELECT SWITCH TO GAUGE LEAD (ALL EXCEPT M577A3 AND M1068A3).....	0281 00
REPLACE INSTRUMENT PANEL ON-OFF SWITCHES	0282 00
REPLACE MAIN LIGHT SWITCH	0283 00
REPLACE ENGINE START SWITCH	0284 00
REPLACE INSTRUMENT PANEL GAUGES	0285 00
REPLACE PANEL LIGHTS AND INDICATOR LIGHTS	0286 00
REPLACE INSTRUMENT PANEL WARNING LIGHTS	0287 00
REPLACE INSTRUMENT WARNING LIGHT PANEL	0288 00
REPLACE INSTRUMENT PANEL BATTERY-GENERATOR GAUGE WIRING HARNESS	0289 00 ■
REPLACE INSTRUMENT PANEL SPECIAL PURPOSE CABLE.....	0290 00
REPLACE WARNING LIGHT PANEL ASSEMBLY (ALL EXCEPT M58).....	0291 00
REPLACE WARNING LIGHT PANEL (ALL EXCEPT M58).....	0292 00
REPLACE HORN SWITCH (ALL EXCEPT M58)	0293 00
REPLACE HORN SWITCH (M58 ONLY)	0293 01
REPLACE WARNING PANEL LIGHTS (ALL EXCEPT M58).....	0294 00
REPLACE WARNING PANEL LIGHTS (M58 ONLY)	0294 01
REPLACE INSTRUMENT PANEL MOUNTS AND GROUND LEAD (ALL EXCEPT M58)	0295 00
REPLACE INSTRUMENT PANEL MOUNTS AND GROUND LEAD (M58 ONLY)	0295 01
REPLACE TELEPOSTS AND COVER	0296 00
REPLACE SOLID STATE INFRARED POWER SUPPLY	0297 00
REPLACE STOP LIGHT-TAIL LIGHT AND GUARDS (ALL EXCEPT M577A3 AND M1068A3)	0298 00
REPLACE LEFT STOP LIGHT-TAIL LIGHT (M577A3 AND M1068A3 ONLY)	0299 00
REPAIR LEFT STOP LIGHT-TAIL LIGHT	0300 00
REPLACE RIGHT STOP LIGHT-TAIL LIGHT (M577A3 ONLY).....	0301 00
REPAIR RIGHT STOP LIGHT-TAIL LIGHT	0302 00
REPLACE SERVICE AND INFRARED HEADLIGHTS.....	0303 00
REPAIR SERVICE AND INFRARED HEADLIGHTS	0304 00

TABLE OF CONTENTS (cont)

	<u>WP Sequence No.</u>
REPLACE BLACKOUT HEADLIGHT	0305 00
REPAIR BLACKOUT HEADLIGHT	0306 00
REPLACE BLACKOUT MARKER LIGHT.....	0307 00
REPAIR BLACKOUT MARKER LIGHT	0308 00
REPLACE DOME LIGHT (ALL EXCEPT M577A3 AND M1068A3).....	0309 00
REPAIR DOME LIGHT (ALL EXCEPT M577A3 AND M1068A3)	0310 00
REPLACE DOME LIGHT (M577A3 AND M1068A3 ONLY)	0311 00
REPAIR DOME LIGHT AND MOUNT (M577A3 AND M1068A3 ONLY).....	0312 00
REPLACE DOME LIGHT LENS (ALL EXCEPT M577A3 AND M1068A3).....	0313 00
REPLACE FRONT DOME LIGHT SWITCH (M577A3 AND M1068A3 ONLY).....	0314 00
REPLACE REAR DOME LIGHT SWITCH (M577A3 AND M1068A3 ONLY)	0315 00
REPLACE DOME LIGHT CIRCUIT BREAKER (M577A3 AND M1068A3 ONLY).....	0316 00
REPLACE DOME BLACKOUT LIGHT BYPASS SWITCH (M577A3 AND M1068A3 ONLY).....	0317 00
REPLACE TENT LIGHT ASSEMBLY (M577A3 AND M1068A3 ONLY).....	0318 00
DELETED.....	0319 00
REPLACE ENGINE OIL LOWPRESSURE TRANSMITTER AND HARDWARE	0320 00
REPLACE COOLANT TEMPERATURE TRANSMITTER	0321 00
REPLACE VARIABLE SPEED FAN DRIVE SENSORS AND SWITCHES (NEW CONFIGURATION).....	0321 01
REPLACE TRANSMISSION OIL HIGH TEMPERATURE SWITCH.....	0322 00
REPLACE GENERATOR FIELD PRESSURE SWITCH.....	0323 00
REPLACE FUEL SUPPLY PRESSURE TRANSDUCER	0324 00
REPLACE FUEL RETURN PRESSURE TRANSDUCER	0325 00
REPLACE TURBO OUTLET PRESSURE TRANSDUCER.....	0326 00
REPLACE AIR BOX PRESSURE TRANSDUCER.....	0327 00
REPLACE FUEL FILTER DIFFERENTIAL PRESSURE SWITCH.....	0328 00
REPLACE AUXILIARY TANK FLUID LEVEL DETECTOR.....	0329 00
REPLACE STEERING LOCK SWITCH.....	0330 00
REPLACE PARKING BRAKE SWITCH/BRACKET	0331 00
REPLACE STOP SWITCH	0332 00
REPLACE HEADLIGHT HIGH BEAM SELECTOR SWITCH	0333 00
REPLACE ADMITTANCE BUZZER AND SWITCH (M577A3 AND M1068A3 ONLY)	0334 00
REPLACE RAMP DOOR SWITCH AND MOUNT (M577A3 AND M1068A3 ONLY).....	0335 00
REPLACE HORN AND GROUND LEAD.....	0336 00
DISCONNECT/CONNECT BATTERY GROUND STRAP (M113A3,	

TABLE OF CONTENTS (cont)

	<u>WP Sequence No.</u>
M1059A3, M1064A3, AND M58 ONLY).....	0337 00
DISCONNECT/CONNECT BATTERY GROUND LEAD (M577A3 AND M1068A3 ONLY).....	0338 00
DELETED.....	0339 00
REPLACE BATTERY LEADS AND TERMINALS (M113A3 AND M1059A3 ONLY)	0340 00
REPLACE BATTERY LEADS AND TERMINALS (M577A3 AND M1068A3 ONLY)	0341 00
DELETED.....	0342 00
REPLACE BATTERY LEADS AND TERMINALS (LEFT SIDE) (M1064A3 ONLY)	0343 00
REPLACE BATTERY LEADS AND TERMINALS (RIGHT SIDE) (M1064A3 ONLY).....	0344 00
REPLACE BATTERY LEADS AND TERMINALS (M58 ONLY)	0345 00
REPLACE BATTERIES AND RETAINERS (M113A3 AND M1059A3 ONLY)	0346 00
REPLACE BATTERIES AND RETAINERS (M577A3 AND M1068A3 ONLY).....	0347 00
REPLACE BATTERIES AND BATTERY BOX (M58 ONLY).....	0348 00
REPLACE BATTERIES AND RETAINERS (M1064A3 ONLY)	0349 00
REPAIR BATTERY BOX (M113A3 AND M1059A3 ONLY).....	0350 00
REPAIR BATTERY BOX (M577A3 AND M1068A3 ONLY).....	0351 00
REPAIR BATTERY BOX ACCESS COVER (M577A3 AND M1068A3 ONLY).....	0352 00
REPAIR BATTERY DRAWER (M1064A3 ONLY).....	0353 00
REPAIR BATTERY BOX (RIGHT SIDE) (M1064A3)	0354 00
REPLACE BATTERY BOX VENT FITTING (M58 ONLY).....	0355 00
REPLACE BATTERY TO MASTER SWITCH LEAD (CIRCUIT 6) (M113A3 AND M1059A3).....	0356 00
REPLACE BATTERY TO MASTER SWITCH LEAD (CIRCUIT 6) (M577A3 AND M1068A3 ONLY)	0357 00
REPLACE BATTERY TO MASTER SWITCH LEAD (CIRCUIT 6) (M1064A3 ONLY)	0358 00
REPLACE ENGINE WIRING HARNESS	0359 00
REPLACE VARIABLE SPEED FAN DRIVE WIRING HARNESS, 3W1 (NEW CONFIGURATION).....	0359 01
REPLACE TRANSMISSION WIRING HARNESS	0360 00
REPLACE TRANSMISSION CONTROLLER WIRING HARNESS	0361 00
REPLACE REAR MAIN WIRING HARNESS (M113A3, M1059A3, AND M58)	0362 00
REPLACE REAR MAIN WIRING HARNESS (M577A3 ONLY).....	0363 00
REPLACE REAR MAIN WIRING HARNESS (M1064A3 ONLY).....	0364 00
REPLACE REAR MAIN WIRING HARNESS (M1068A3 ONLY).....	0365 00
REPLACE SMOKE GRENADE LAUNCHER WIRING HARNESS (M113A3, M1059A3, AND M58 ONLY)	0366 00

TABLE OF CONTENTS (cont)

WP Sequence No.

REPLACE STEERING LOCK SWITCH WIRING HARNESS (ALL EXCEPT M58)..... 0367 00

REPLACE STEERING LOCK SWITCH WIRING HARNESS (M58 ONLY)..... 0367 01

REPLACE DRIVER’S NIGHT VISION (DNV) (AN/VVS-2) POWER SUPPLY CABLE
ASSEMBLY (ALL EXCEPT M58) 0368 00

REPLACE BATTERY-TO-RADIO WIRING HARNESS (LEFT SIDE) (M113A3
AND M1059A3 ONLY)..... 0369 00

REPLACE BATTERY-TO-RADIO WIRING HARNESS (RIGHT SIDE) (M113A3 ONLY) 0370 00

DELETED 0371 00

DELETED 0372 00

REPLACE RIGHT HEADLIGHT WIRING HARNESS 0373 00

REPLACE WARNING PANEL WIRING HARNESS 0374 00

REPLACE TRAILER HARNESS 0375 00

REPLACE RADIAC WIRE HARNESS (M113A3, M577A3, AND M1068A3 ONLY)..... 0376 00

REPLACE UTILITY OUTLET LEAD ASSEMBLY (M577A3 AND M1068A3 ONLY)..... 0377 00

REPLACE REAR UTILITY OUTLET RECEPTACLES (M577A3 AND M1068A3 ONLY)..... 0378 00

REPLACE AUXILIARY POWER (SLAVE) RECEPTACLE GROUND LEAD
(M113A3, M1059A3, M1064A3, AND M58 ONLY) 0379 00

REPLACE MASTER SWITCH PANEL DOME LIGHTS LEAD ASSEMBLY (M577A3
AND M1068A3 ONLY)..... 0380 00

REPAIR INTERVEHICLE POWER CABLE (M577A3 AND M1068A3 ONLY)..... 0381 00

REPAIR WIRING HARNESS..... 0382 00

REPLACE VENTILATION FAN (M577A3 AND M1068A3 ONLY) 0383 00

CHAPTER 9 —UNIT MAINTENANCE INSTRUCTIONS FOR TRANSMISSION

REPLACE TRANSMISSION OIL DRAIN TUBES AND BRACKET..... 0384 00

REPLACE TRANSMISSION MOUNTS 0385 00

REPLACE TRANSMISSION RANGE CONTROLLER/BRACKET (USED WITH
SOLENOID-ACTIVATED STEERING LOCK)..... 0386 00

REPLACE TRANSMISSION RANGE CONTROLLER/BRACKET (USED WITH
CABLE-ACTIVATED STEERING LOCK)..... 0387 00

REPLACE TRANSMISSION RANGE CONTROLLER LAMP..... 0388 00

REPLACE TRANSMISSION RANGE CONTROLLER SWITCH 0389 00

ADJUST TOW START CONTROL CABLE ASSEMBLY 0390 00

REPLACE TOWSTART CONTROL ASSEMBLY AND BEARING 0391 00

REPLACE TOWSTART CONTROL ASSEMBLY COVER..... 0392 00

ADJUST TRANSMISSION STEERING 0393 00

ADJUST TRANSMISSION BRAKES..... 0394 00

REPLACE TRANSMISSION OIL LEVEL DIPSTICK, FILLER TUBE, AND

TABLE OF CONTENTS (cont)

	<u>WP Sequence No.</u>
ADAPTER (X200-4 ONLY).....	0395 00
REPLACE TRANSMISSION OIL LEVEL DIPSTICK, FILLER TUBE, AND ADAPTER (X200-4A ONLY).....	0396 00
REPLACE GOVERNOR ASSEMBLY.....	0397 00
REPLACE TRANSMISSION OIL AND OIL FILTER ELEMENT.....	0398 00
REPLACE TRANSMISSION OIL COOLER HOSES, FITTINGS, AND MOUNTING	0399 00
REPLACE TRANSMISSION OIL SAMPLING VALVE AND PRESSURE SWITCH	0400 00
REPLACE DIFFERENTIAL PRESSURE SWITCH AND BYPASS PLUG.....	0401 00
 CHAPTER 10 – UNIT MAINTENANCE INSTRUCTIONS FOR TRANSFER AND FINAL DRIVE ASSEMBLIES	
REPLACE FINAL DRIVE FILLER TUBE AND DIPSTICK.....	0402 00
REPLACE FINAL DRIVE	0403 00
REPLACE FINAL DRIVE DIFFERENTIAL OIL SEAL	0404 00
 CHAPTER 11 — UNIT MAINTENANCE INSTRUCTIONS FOR PROPELLER SHAFTS AND UNIVERSAL JOINTS	
REPLACE PROPELLER SHAFT AND UNIVERSAL JOINTS.....	0405 00
 CHAPTER 12 — UNIT MAINTENANCE INSTRUCTIONS FOR BRAKES	
CHECK TRANSMISSION BRAKE ADJUSTMENT	0406 00
ADJUST SERVICE BRAKE CONTROL LINKAGE	0407 00
ADJUST PARKING BRAKE	0408 00
REPLACE UPPER AND LOWER SERVICE BRAKE PEDAL.....	0409 00
REPLACE SERVICE BRAKE CONTROL LINKAGE	0410 00
REPLACE PARKING BRAKE CONTROL CABLE ASSEMBLY.....	0411 00
REPLACE PARKING BRAKE CONTROL LEVER ASSEMBLY	0412 00

CHAPTER 8

UNIT MAINTENANCE INSTRUCTIONS
FOR ELECTRICAL SYSTEM

WORK PACKAGE INDEX

<u>Title</u>	<u>WP Sequence No.</u>
ADJUST GENERATOR DRIVE BELT.....	0252 00
REPLACE GENERATOR DRIVE BELT.....	0253 00
REPLACE GENERATOR TURNBUCKLE PARTS.....	0254 00
REPLACE GENERATOR/BRACKET.....	0255 00
ADJUST VOLTAGE REGULATOR.....	0256 00
REPLACE REGULATOR ASSEMBLY.....	0257 00
REPLACE STARTER RELAY SWITCH.....	0258 00
REPLACE STARTER.....	0259 00
REPLACE MASTER SWITCH PANEL ASSEMBLY (M113A3, M1059A3, M1064A3, AND M58 ONLY).....	0260 00
REPLACE MASTER SWITCH PANEL ASSEMBLY (M577A3 AND M1068A3 ONLY).....	0261 00
REPLACE MASTER SWITCH (M113A3, M1059A3, M1064A3, AND M58 ONLY).....	0262 00
REPLACE AUXILIARY POWER (SLAVE) RECEPTACLE (M113A3, M1059A3, M1064A3, AND M58 ONLY).....	0263 00
REPLACE NATO AUXILIARY POWER (SLAVE) RECEPTACLE (M577A3 AND M1068A3 ONLY).....	0264 00
REPLACE UTILITY OUTLET RECEPTACLE.....	0265 00
REPLACE MASTER SWITCH TO DISTRIBUTION BOX LEAD (CIRCUIT 49) (M113A3, M1059A3, M1064A3, AND M58 ONLY).....	0266 00
REPLACE MASTER SWITCH TO DISTRIBUTION BOX LEAD (CIRCUIT 49) (M577A3 AND M1068A3 ONLY).....	0267 00
REPLACE MASTER SWITCH TO AUXILIARY POWER RECEPTACLE LEAD (CIRCUIT 50) (M113A3, M1059A3, M1064A3, AND M58).....	0268 00
REPLACE DISTRIBUTION BOX (M113A3, M1059A3, M1064A3, AND M58 ONLY).....	0269 00
REPAIR DISTRIBUTION BOX (M113A3, M1059A3, M1064A3, AND M58 ONLY).....	0270 00
REPLACE DISTRIBUTION BOX ASSEMBLY (M577A3 AND M1068A3 ONLY).....	0271 00
DELETED.....	0272 00
DELETED.....	0273 00
DELETED.....	0274 00
REPLACE BILGE PUMP CIRCUIT BREAKERS.....	0275 00
REPLACE REAR UTILITY RECEPTACLE CIRCUIT BREAKERS (M577A3 AND M1068A3 ONLY).....	0276 00
REPLACE FUEL SELECTOR SWITCH (M577A3 AND M1068A3 ONLY).....	0277 00

CHAPTER 8

UNIT MAINTENANCE INSTRUCTIONS
FOR ELECTRICAL SYSTEM

WORK PACKAGE INDEX (Continued)

<u>Title</u>	<u>WP Sequence No</u>
REPLACE BLOWER SWITCH (M577A3 AND M1068A3 ONLY).....	0278 00
REPLACE INSTRUMENT PANEL ASSEMBLY (ALL EXCEPT M58)	0279 00
REPLACE INSTRUMENT PANEL ASSEMBLY (M58 ONLY)	0279 01
REPLACE CIRCUIT BREAKER.....	0280 00
REPLACE FUEL SELECT SWITCH TO GAUGE LEAD (ALL EXCEPT M577A3 AND M1068A3).....	0281 00
REPLACE INSTRUMENT PANEL ON-OFF SWITCHES	0282 00
REPLACE MAIN LIGHT SWITCH	0283 00
REPLACE ENGINE START SWITCH	0284 00
REPLACE INSTRUMENT PANEL GAUGES	0285 00
REPLACE PANEL LIGHTS AND INDICATOR LIGHTS	0286 00
REPLACE INSTRUMENT PANEL WARNING LIGHTS	0287 00
REPLACE INSTRUMENT WARNING LIGHT PANEL	0288 00
REPLACE INSTRUMENT PANEL BATTERY-GENERATOR GAUGE WIRING HARNESS	0289 00
REPLACE INSTRUMENT PANEL SPECIAL PURPOSE CABLE	0290 00
REPLACE WARNING LIGHT PANEL ASSEMBLY (ALL EXCEPT M58).....	0291 00
REPLACE WARNING LIGHT PANEL (ALL EXCEPT M58)	0292 00
REPLACE HORN SWITCH (ALL EXCEPT M58).....	0293 00
REPLACE HORN SWITCH (M58 ONLY)	0293 01
REPLACE WARNING PANEL LIGHTS (ALL EXCEPT M58).....	0294 00
REPLACE WARNING PANEL LIGHTS (M58 ONLY).....	0294 01
REPLACE INSTRUMENT PANEL MOUNTS AND GROUND LEAD (ALL EXCEPT M58).....	0295 00
REPLACE INSTRUMENT PANEL MOUNTS AND GROUND LEAD (M58 ONLY)	0295 01
REPLACE TELEPOSTS AND COVER	0296 00
REPLACE SOLID STATE INFRARED POWER SUPPLY	0297 00
REPLACE STOP LIGHT-TAIL LIGHT AND GUARDS (ALL EXCEPT M577A3 AND M1068A3).....	0298 00
REPLACE LEFT STOP LIGHT-TAIL LIGHT (M577A3 AND M1068A3 ONLY)	0299 00
REPAIR LEFT STOP LIGHT-TAIL LIGHT	0300 00
REPLACE RIGHT STOP LIGHT-TAIL LIGHT (M577A3 ONLY).....	0301 00
REPAIR RIGHT STOP LIGHT-TAIL LIGHT	0302 00

CHAPTER 8

UNIT MAINTENANCE INSTRUCTIONS
FOR ELECTRICAL SYSTEM

WORK PACKAGE INDEX (Continued)

<u>Title</u>	<u>WP Sequence No.</u>
REPLACE SERVICE AND INFRARED HEADLIGHTS.....	0303 00
REPAIR SERVICE AND INFRARED HEADLIGHTS	0304 00
REPLACE BLACKOUT HEADLIGHT	0305 00
REPAIR BLACKOUT HEADLIGHT.....	0306 00
REPLACE BLACKOUT MARKER LIGHT	0307 00
REPAIR BLACKOUT MARKER LIGHT.....	0308 00
REPLACE DOME LIGHT (ALL EXCEPT M577A3 AND M1068A3)	0309 00
REPAIR DOME LIGHT (ALL EXCEPT M577A3 AND M1068A3).....	0310 00
REPLACE DOME LIGHT (M577A3 AND M1068A3 ONLY).....	0311 00
REPAIR DOME LIGHT AND MOUNT (M577A3 AND M1068A3 ONLY)	0312 00
REPLACE DOME LIGHT LENS (ALL EXCEPT M577A3 AND M1068A3)	0313 00
REPLACE FRONT DOME LIGHT SWITCH (M577A3 AND M1068A3 ONLY).....	0314 00
REPLACE REAR DOME LIGHT SWITCH (M577A3 AND M1068A3 ONLY)	0315 00
REPLACE DOME LIGHT CIRCUIT BREAKER (M577A3 AND M1068A3 ONLY).....	0316 00
REPLACE DOME BLACKOUT LIGHT BYPASS SWITCH (M577A3 AND M1068A3 ONLY).....	0317 00
REPLACE TENT LIGHT ASSEMBLY (M577A3 AND M1068A3 ONLY)	0318 00
DELETED.....	0319 00
REPLACE ENGINE OIL LOWPRESSURE TRANSMITTER AND HARDWARE	0320 00
REPLACE COOLANT TEMPERATURE TRANSMITTER	0321 00
REPLACE VARIABLE SPEED FAN DRIVE SENSORS AND SWITCHES (NEW CONFIGURATION).....	0321 01
REPLACE TRANSMISSION OIL HIGH TEMPERATURE SWITCH.....	0322 00
REPLACE GENERATOR FIELD PRESSURE SWITCH.....	0323 00
REPLACE FUEL SUPPLY PRESSURE TRANSDUCER.....	0324 00
REPLACE FUEL RETURN PRESSURE TRANSDUCER.....	0325 00
REPLACE TURBO OUTLET PRESSURE TRANSDUCER.....	0326 00
REPLACE AIR BOX PRESSURE TRANSDUCER.....	0327 00
REPLACE FUEL FILTER DIFFERENTIAL PRESSURE SWITCH.....	0328 00
REPLACE AUXILIARY TANK FLUID LEVEL DETECTOR.....	0329 00
REPLACE STEERING LOCK SWITCH.....	0330 00
REPLACE PARKING BRAKE SWITCH/BRACKET.....	0331 00

CHAPTER 8

UNIT MAINTENANCE INSTRUCTIONS
FOR ELECTRICAL SYSTEM

WORK PACKAGE INDEX (Continued)

<u>Title</u>	<u>WP Sequence No</u>
REPLACE STOP SWITCH	0332 00
REPLACE HEADLIGHT HIGH BEAM SELECTOR SWITCH	0333 00
REPLACE ADMITTANCE BUZZER AND SWITCH (M577A3 AND M1068A3 ONLY)	0334 00
REPLACE RAMP DOOR SWITCH AND MOUNT (M577A3 AND M1068A3 ONLY).....	0335 00
REPLACE HORN AND GROUND LEAD.....	0336 00
DISCONNECT/CONNECT BATTERY GROUND STRAP (M113A3, M1059A3, M1064A3, AND M58 ONLY).....	0337 00
DISCONNECT/CONNECT BATTERY GROUND LEAD (M577A3 AND M1068A3 ONLY).....	0338 00
DELETED.....	0339 00
REPLACE BATTERY LEADS AND TERMINALS (M113A3 AND M1059A3 ONLY)	0340 00
REPLACE BATTERY LEADS AND TERMINALS (M577A3 AND M1068A3 ONLY)	0341 00
DELETED.....	0342 00
REPLACE BATTERY LEADS AND TERMINALS (LEFT SIDE) (M1064A3 ONLY)	0343 00
REPLACE BATTERY LEADS AND TERMINALS (RIGHT SIDE) (M1064A3 ONLY).....	0344 00
REPLACE BATTERY LEADS AND TERMINALS (M58 ONLY)	0345 00
REPLACE BATTERIES AND RETAINERS (M113A3 AND M1059A3 ONLY)	0346 00
REPLACE BATTERIES AND RETAINERS (M577A3 AND M1068A3 ONLY).....	0347 00
REPLACE BATTERIES AND BATTERY BOX (M58 ONLY).....	0348 00
REPLACE BATTERIES AND RETAINERS (M1064A3 ONLY)	0349 00
REPAIR BATTERY BOX (M113A3 AND M1059A3 ONLY).....	0350 00
REPAIR BATTERY BOX (M577A3 AND M1068A3 ONLY).....	0351 00
REPAIR BATTERY BOX ACCESS COVER (M577A3 AND M1068A3 ONLY).....	0352 00
REPAIR BATTERY DRAWER (M1064A3 ONLY).....	0353 00
REPAIR BATTERY BOX (RIGHT SIDE) (M1064A3)	0354 00
REPLACE BATTERY BOX VENT FITTING (M58 ONLY).....	0355 00
REPLACE BATTERY TO MASTER SWITCH LEAD (CIRCUIT 6) (M113A3 AND M1059A3 ONLY).....	0356 00
REPLACE BATTERY TO MASTER SWITCH LEAD (CIRCUIT 6) (M577A3 AND M1068A3 ONLY)	0357 00
REPLACE BATTERY TO MASTER SWITCH LEAD (CIRCUIT 6) (M1064A3 ONLY)	0358 00

CHAPTER 8

UNIT MAINTENANCE INSTRUCTIONS
FOR ELECTRICAL SYSTEM

WORK PACKAGE INDEX (Continued)

<u>Title</u>	<u>WP Sequence No.</u>
REPLACE ENGINE WIRING HARNESS	0359 00
REPLACE VARIABLE SPEED FAN DRIVE WIRING HARNESS, 3W1 (NEW CONFIGURATION)	0359 01
REPLACE TRANSMISSION WIRING HARNESS	0360 00
REPLACE TRANSMISSION CONTROLLER WIRING HARNESS	0361 00
REPLACE REAR MAIN WIRING HARNESS (M113A3, M1059A3, AND M58)	0362 00
REPLACE REAR MAIN WIRING HARNESS (M577A3 ONLY).....	0363 00
REPLACE REAR MAIN WIRING HARNESS (M1064A3 ONLY).....	0364 00
REPLACE REAR MAIN WIRING HARNESS (M1068A3 ONLY).....	0365 00
REPLACE SMOKE GRENADE LAUNCHER WIRING HARNESS (M113A3, M1059A3, AND M58 ONLY)	0366 00
REPLACE STEERING LOCK SWITCH WIRING HARNESS (ALL EXCEPT M58).....	0367 00
REPLACE STEERING LOCK SWITCH WIRING HARNESS (M58 ONLY)	0367 01
REPLACE DRIVER'S NIGHT VISION (DNV) (AN/VVS-2) POWER SUPPLY CABLE ASSEMBLY (ALL EXCEPT M58).....	0368 00
REPLACE BATTERY-TO-RADIO WIRING HARNESS (LEFT SIDE) (M113A3 AND M1059A3 ONLY).....	0369 00
REPLACE BATTERY-TO-RADIO WIRING HARNESS (RIGHT SIDE) (M113A3 ONLY)	0370 00
DELETED.....	0371 00
DELETED.....	0372 00
REPLACE RIGHT HEADLIGHT WIRING HARNESS.....	0373 00
REPLACE WARNING PANEL WIRING HARNESS.....	0374 00
REPLACE TRAILER HARNESS	0375 00
REPLACE RADIAC WIRE HARNESS (M113A3, M577A3, AND M1068A3 ONLY).....	0376 00
REPLACE UTILITY OUTLET LEAD ASSEMBLY (M577A3 AND M1068A3 ONLY).....	0377 00
REPLACE REAR UTILITY OUTLET RECEPTACLES (M577A3 AND M1068A3 ONLY).....	0378 00
REPLACE AUXILIARY POWER (SLAVE) RECEPTACLE GROUND LEAD (M113A3, M1059A3, M1064A3, AND M58 ONLY).....	0379 00
REPLACE MASTER SWITCH PANEL DOME LIGHTS LEAD ASSEMBLY (M577A3 AND M1068A3 ONLY).....	0380 00
REPAIR INTERVEHICLE POWER CABLE (M577A3 AND M1068A3 ONLY).....	0381 00
REPAIR WIRING HARNESS.....	0382 00
REPLACE VENTILATION FAN (M577A3 AND M1068A3 ONLY).....	0383 00

ADJUST GENERATOR DRIVE BELT

0252 00

THIS WORK PACKAGE COVERS:

Adjustment (page 0252 00-2).

INITIAL SETUP:

Maintenance Level

Unit

Personnel Required

Unit Mechanic

Tools and Special Tools

General Mechanic's Tool Kit (WP 0926 00, Item 65)
 Tensiometer (WP 0926 00, Item 59)
 Torque Wrench (WP 0926 00, Item 85)
 Yardstick (WP 0926 00, Item 87)
 Yardstick (WP 0926 00, Item 88)

References

See your -10

Equipment Condition

Engine stopped (see your -10)
 Carrier blocked (see your -10)
 Rear power plant access panels removed (see your -10)

ADJUSTMENT

NOTE

To allow for initial belt stretching, make sure belt tension is rechecked after 30 minutes of operation.

1. Check generator drive belt (1) for damage. If damaged, replace drive belt (WP 0253 00).
2. Position lower O-ring (2) on tensiometer (3) at maximum allowable belt deflection of 1/4 inch (0.6 cm) to 3/8 inch (1.0 cm).
3. Position upper O-ring (4) on tensiometer (3) to zero.
4. Place yardstick (5) on pulleys (6) and (7).
5. Place tensiometer (3) on belt (1) at midspan and at right angle to belt.
6. Press on top of tensiometer (3) until lower O-ring (2) aligns with bottom of yardstick (5). Remove tensiometer.
7. Take tensiometer reading at point where upper O-ring (4) stopped. Initial reading must be 15-17 lbs (7-8 kg). After 30 minutes of operation, reading must be 12-14 lbs (5-6 kg).

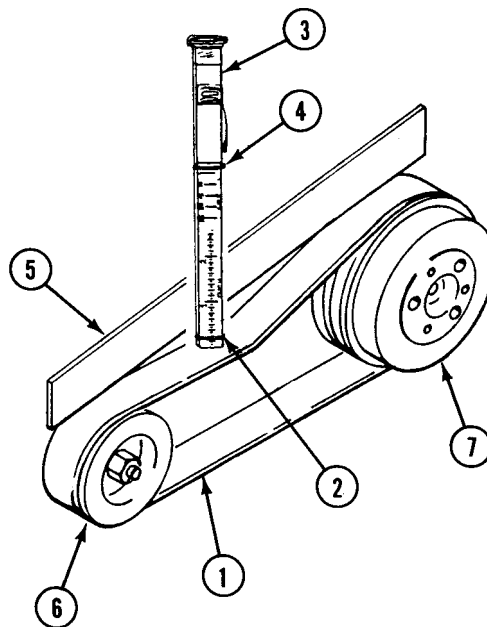

8. Adjust drive belt as follows:
 - a. Loosen two support screws (1) on top of generator (2).
 - b. Loosen jamnut (3) and adjust turnbuckle (4) until belt is at the right tension. Tighten jamnut.
 - c. TIGHTEN TWO SUPPORT SCREWS (1) TO 56-61 LB-FT (76-81 N·m) TORQUE.

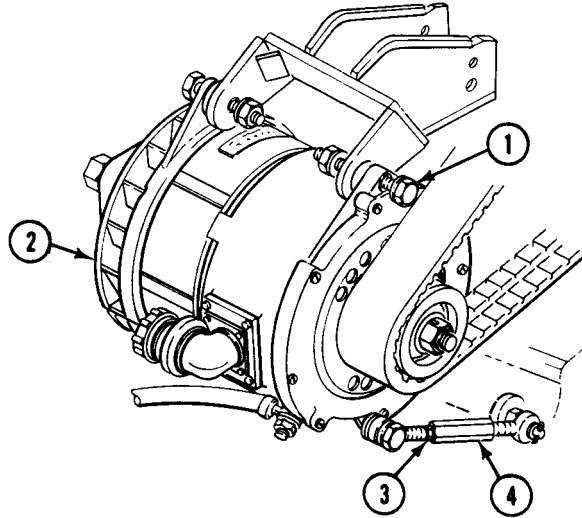
**FOLLOW-THROUGH STEPS**

1. Install rear power plant access panels (see your -10).

END OF TASK

REPLACE GENERATOR DRIVE BELT

0253 00

THIS WORK PACKAGE COVERS:

Removal (page 0253 00-1).
 Installation (page 0253 00-2).

INITIAL SETUP:

Maintenance Level

Unit

References

See your -10

Tools and Special Tools

General Mechanic's Tool Kit (WP 0926 00, Item 65)

Equipment Condition

Engine stopped (see your -10)
 Carrier blocked (see your -10)
 Lower rear power plant access panel removed (see your -10)
 Driver's power plant access panel removed (see your -10)

Materials/Parts

Belt

Personnel Required

Unit Mechanic

REMOVAL

1. Loosen turnbuckle jam nut (1).
2. Loosen two generator mounting screws (2).
3. Loosen turnbuckle (3) and remove drive belt (4). Discard belt.

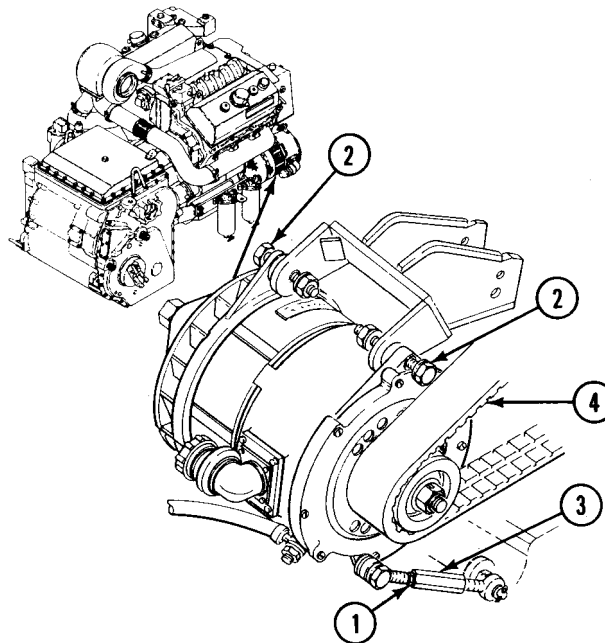

INSTALLATION

1. Install new drive belt (4).

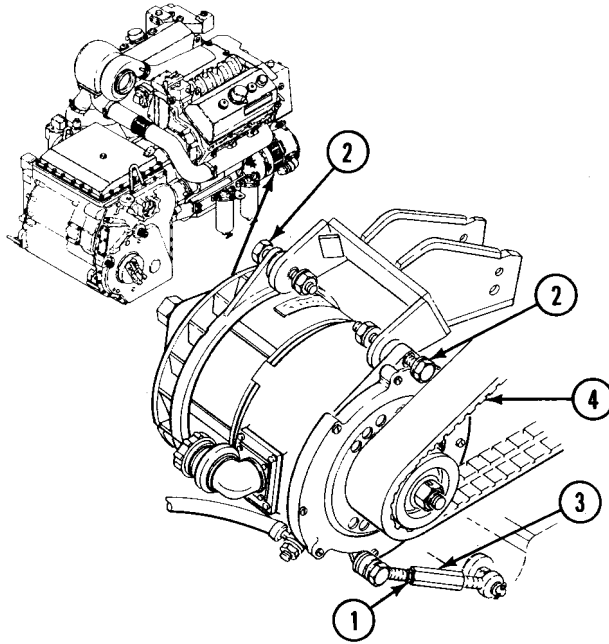

2. Adjust drive belt (WP 0252 00).

FOLLOW-THROUGH STEPS

1. Install lower rear power plant access panel (see your -10).
2. Install driver's power plant access panel (see your -10).

END OF TASK

REPLACE GENERATOR TURNBUCKLE PARTS

0254 00

THIS WORK PACKAGE COVERS:

Removal (page 0254 00-1).
 Installation (page 0254 00-2).

INITIAL SETUP:

Maintenance Level

Unit

References

TM 9-2350-277-10

Tools and Special Tools

General Mechanic's Tool Kit (WP 0926 00, Item 65)

Equipment Condition

Engine stopped (see your -10)

Carrier blocked (see your -10)

Materials/Parts

Cotter pin

Lockwasher

Lower rear power plant access panel removed
 (see your -10)

Personnel Required

Unit Mechanic

REMOVAL

1. Loosen jam nut (1). Rotate turnbuckle (2) to loosen drive belt.
2. Remove cotter pin (3) and washer (4). Discard cotter pin.
3. Remove screw (5), washer (6), turnbuckle screw end (7), spacer (8), and washer (9) from generator (10).
4. Remove turnbuckle screw ends (7) and (11) from turnbuckle sleeve (2).
5. Remove pin (12), lockwasher (13), and washer (14) from bracket (15). Discard lockwasher.

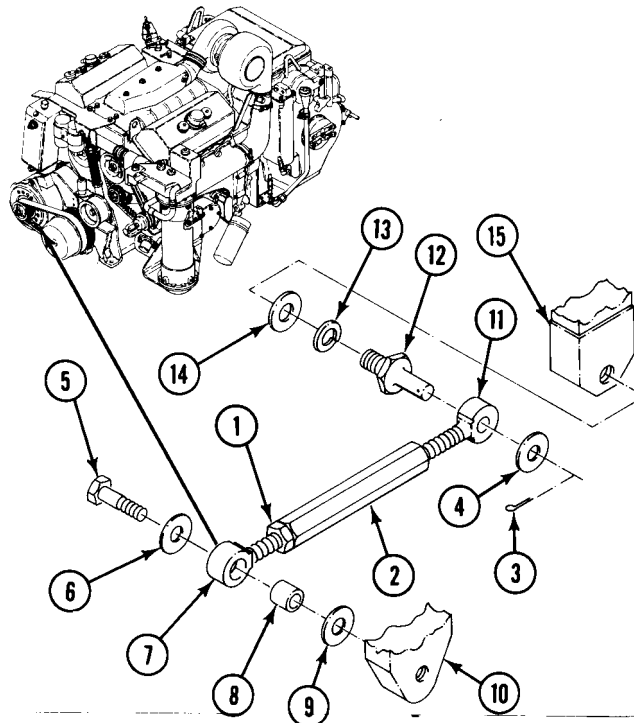

INSTALLATION

1. Install washer (14), new lockwasher (13), and pin (12) in bracket (15).
2. Install jam nut (1) on screw end (7). Install screw ends (7) and (11) into turnbuckle sleeve (2). Center screw ends in sleeve.
3. Install screw end (11) on pin (12) and secure with washer (4) and new cotter pin (3).
4. Install washer (6), screw (5), and spacer (8) in screw end (7). Install washer (9) on screw (5) and secure to generator (10).

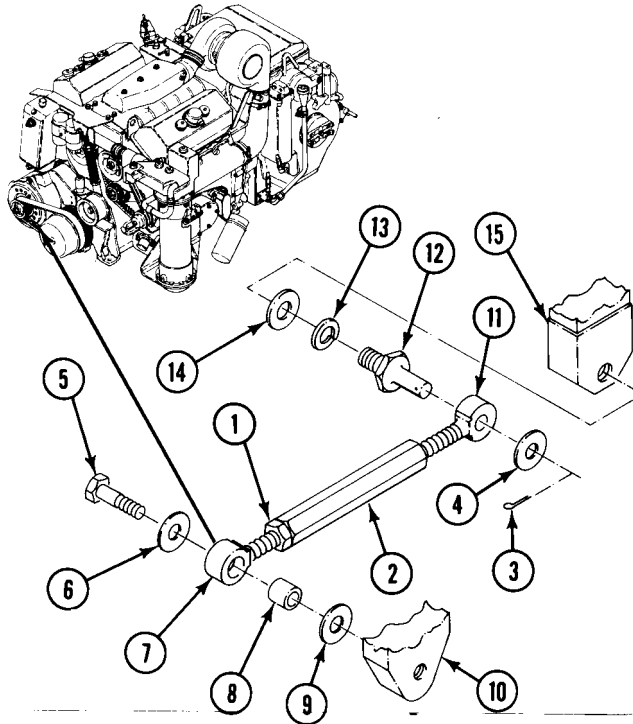
**FOLLOW-THROUGH STEPS**

1. Adjust generator drive belt (WP 0252 00).
2. Install lower rear power plant access panel (see your -10).

END OF TASK

REPLACE GENERATOR/BRACKET

0255 00

THIS WORK PACKAGE COVERS:

Removal (page 0255 00-1).
 Installation (page 0255 00-4).

INITIAL SETUP:

Maintenance Level

Unit

References

See your -10

Tools and Special Tools

General Mechanic's Tool Kit (WP 0926 00, Item 65)
 Torque Wrench (WP 0926 00, Item 65)
 Puller (WP 0926 00, Item 38)

Equipment Condition

Engine stopped (see your -10)
 Carrier blocked (see your -10)
 Driver's power plant access panel removed (see your -10)
 Power plant lower rear access panel removed (see your -10)
 Battery ground strap disconnected (WP 0337 00), (WP 0338 00), or (WP 0339 00)
 Generator drive belt removed (WP 0253 00)

Materials/Parts

Locknut (2)
 Key

Personnel Required

Unit Mechanic
 Helper (H)

REMOVAL

1. Remove nut (7), washer (8), and ground lead (9) from generator (2).
2. Remove harness circuit lead (1) from generator (2).
3. Remove screw (6), two washers (5), spacer (4), and turnbuckle (3) from generator (2).

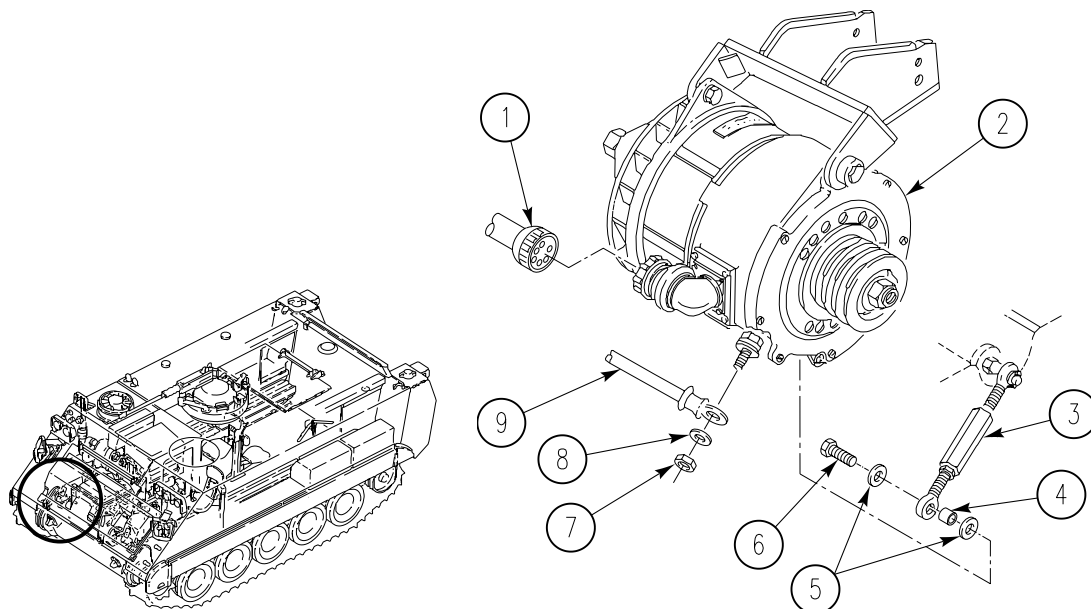

WARNING

Generator weighs 80 lb (37 kg) and can cause back injury if handled improperly. Be sure to use a hoist or a helper to remove generator.

4. Remove two screws (1), locknuts (2), and three washers (3) from generator (9). Remove generator from bracket (4). Have helper assist. Discard locknuts.

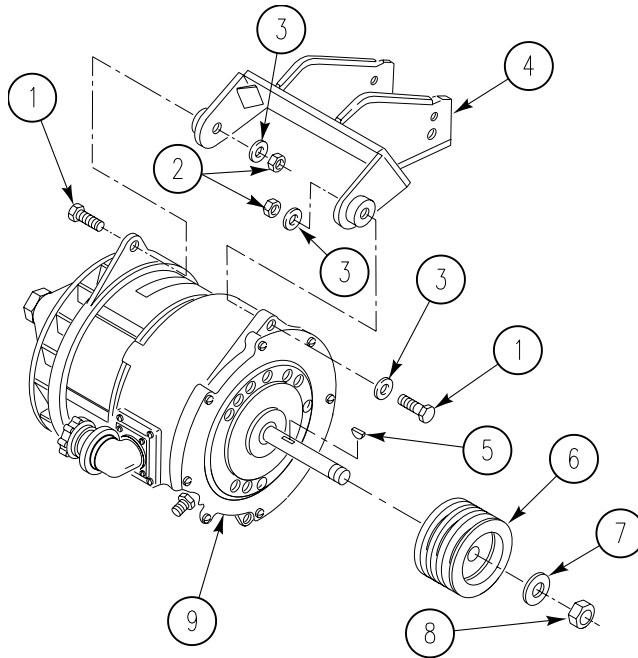

NOTE

Do Step 5 if bracket needs to be removed.

5. Remove three screws (2), (5), and (6), washers (3), (4), and (7), and bracket (1) from engine block.

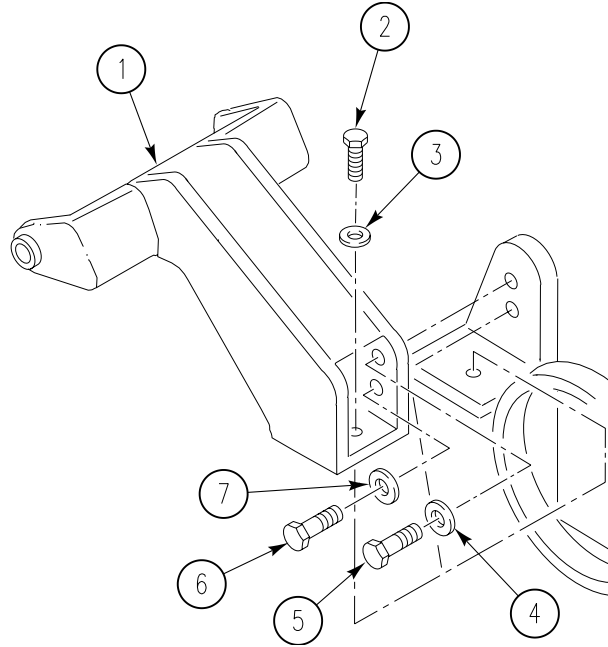

NOTE

It may be necessary to use puller to remove pulley from generator.

6. Remove nut (8), washer (7), pulley (6), and key (5) from generator (9). Discard nut, washer and key.

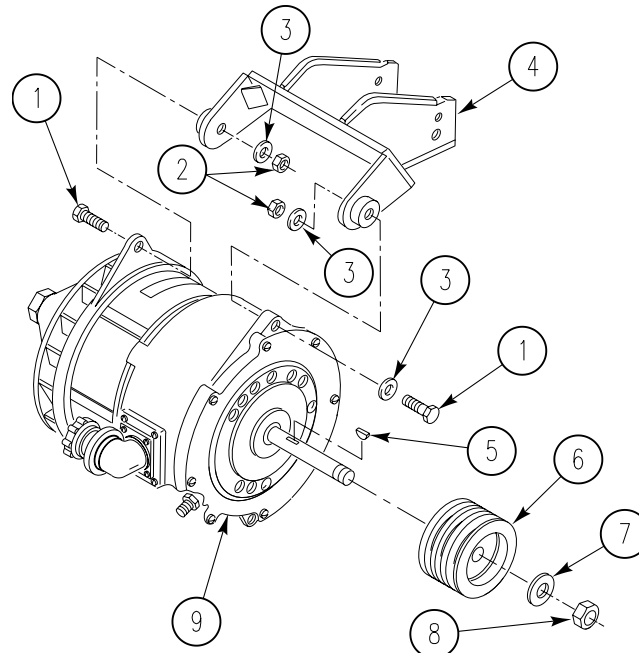

INSTALLATION

NOTE

Use nut and washer furnished with new generator.

1. Install new key (5) and pulley (6) on new generator (9). Secure with new nut (8) and washer (7).

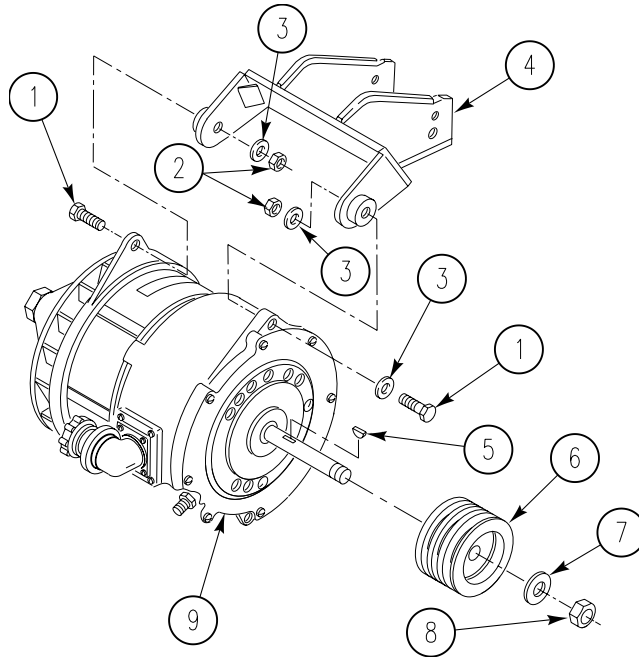

NOTE

The pulley locknut must be tightened. Follow Steps 2 - 6. Performing these steps will lock the shaft in place with no damage. After the locknut is tightened, the generator is ready to be installed.

2. Loop the pulley belt (1) on the bottom groove of the pulley (2)

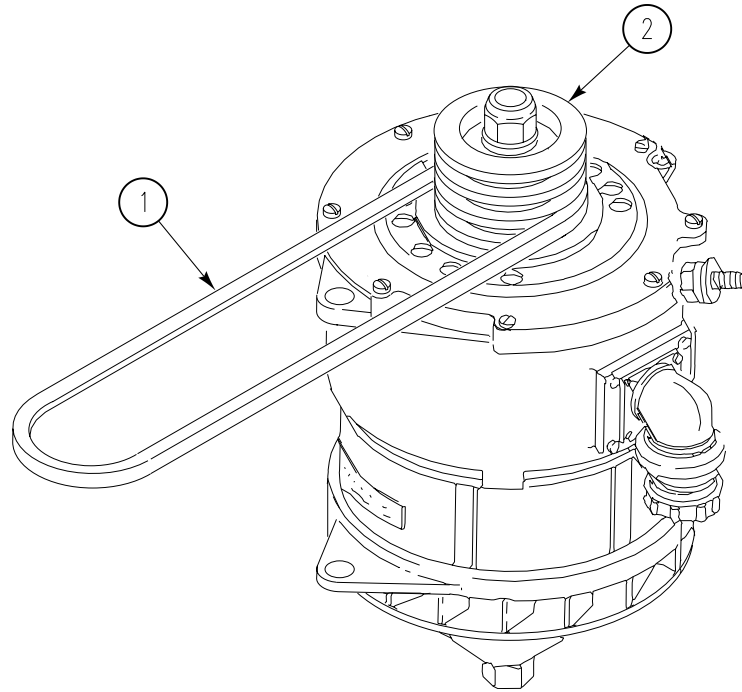

3. Cross the pulley belt (1) and put the other loop on the top groove of the pulley (2).

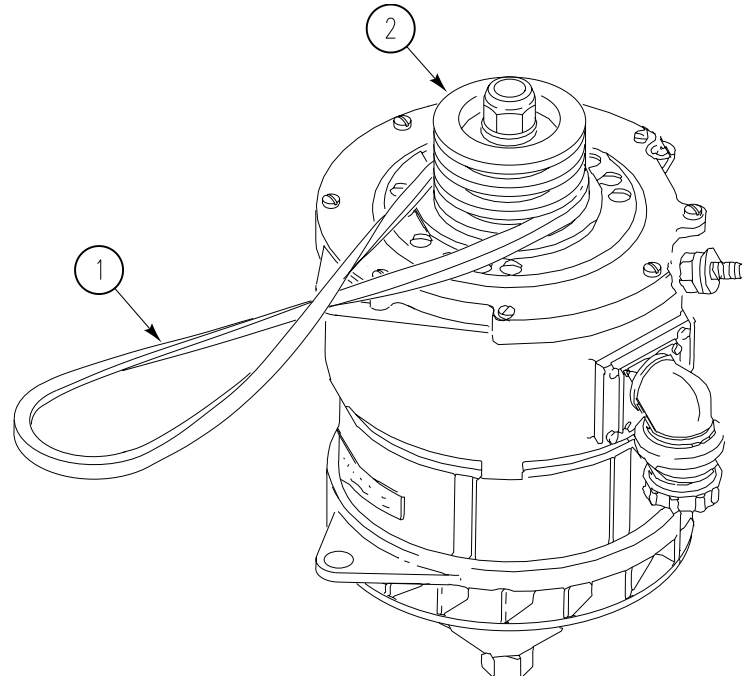

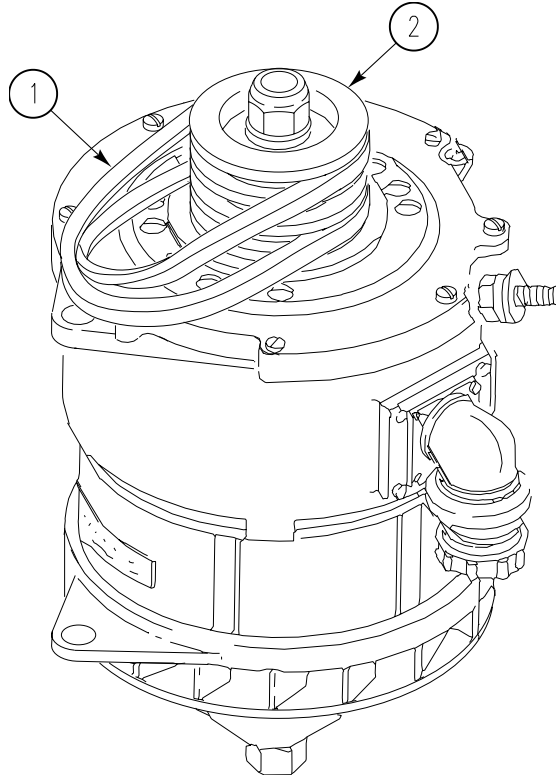

4. Stretch the crossed end of the pulley belt (1) over the generator's mounting ear (2).

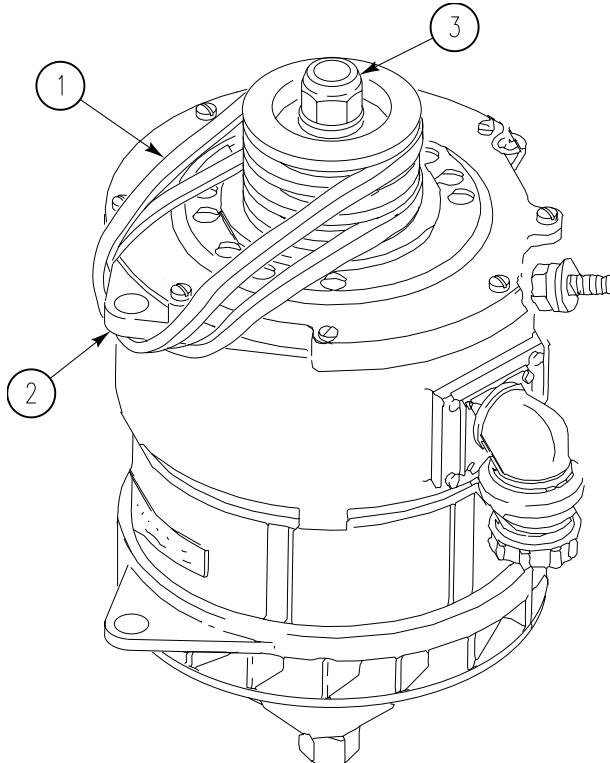

5. TORQUE NUT (3) TO 70 - 75 LB-FT (95 - 102 N·m).

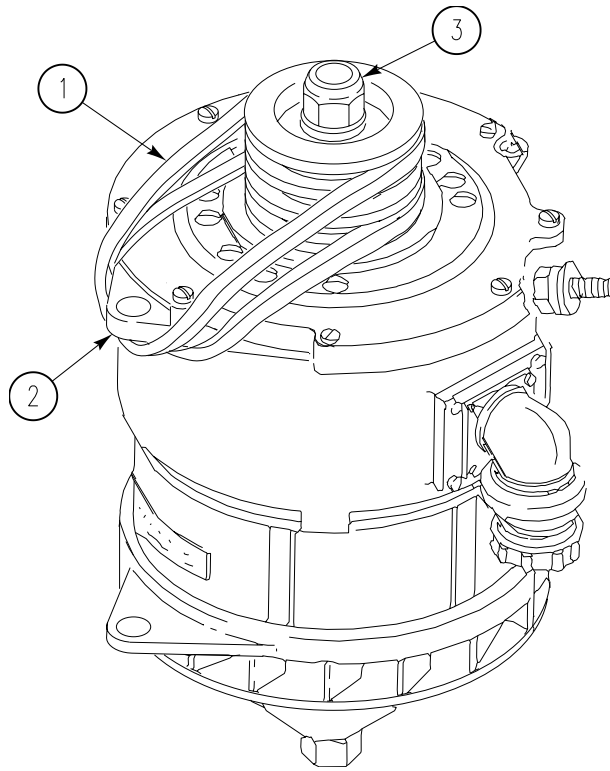

6. Remove pulley belt (1) from pulley (2).

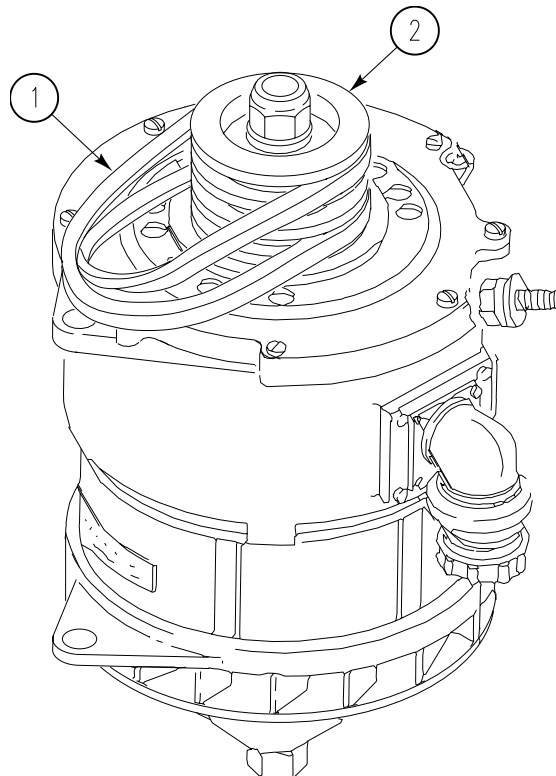

NOTE

Do Step 7 and Step 8 if bracket was removed.

NOTE

Do not tighten bracket mounting screws until all mounting screws have been installed. All three screws require a specific torque.

7. Position bracket (1) on engine block and install screw (2) and washer (3). Align bracket holes with block holes and install screws (5) and (6) and washers (4) and (7).
8. Tighten screws (2), (5), and (6) to the following torque values:

Torque Values

<u>SCREW</u>	<u>TORQUE</u>
2	32-34 lb-ft (43-46 N·m)
5	36-38 lb-ft (49-52 N·m)
6	32-34 lb-ft (43-46 N·m)

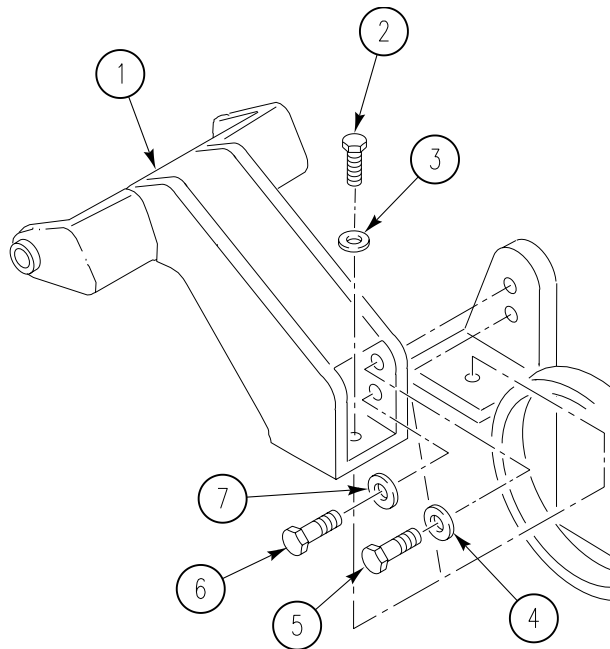

NOTE

Use bushing furnished with new generator.

9. Install generator (9) on bracket (4). Secure with two screws (1), new locknuts (2), and three washers (3).

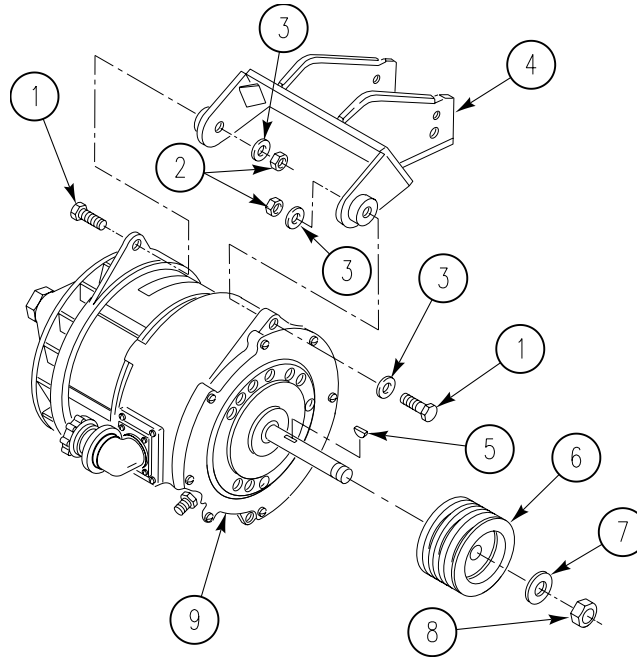

10. Install turnbuckle (3) on generator (2). Secure with screw (6), two washers (5), and spacer (4).
11. Install harness circuit lead (1) on generator (2).
12. Install ground lead (9) on generator (2). Secure with nut (7) and washer (8).

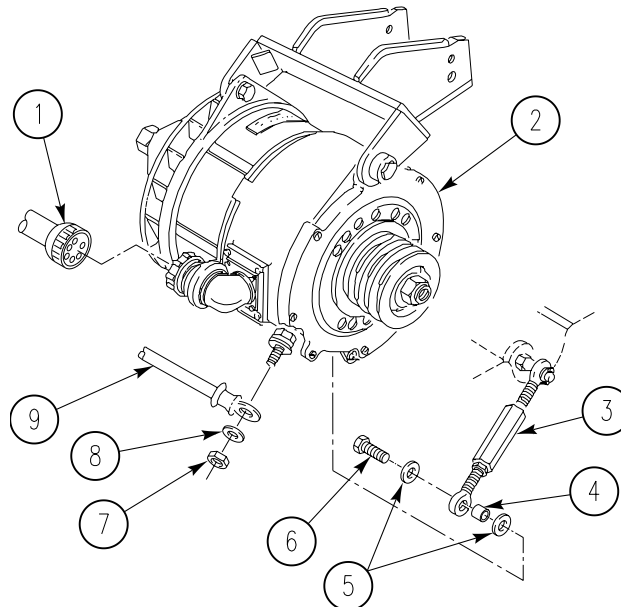

13. Install generator drive belt (WP 0253 00).
14. Adjust generator drive belt (WP 0252 00).
15. TORQUE SCREWS (1) SECURING GENERATOR (9) TO BRACKET (4) TO 36-38 LB-FT (49-52 N·m).

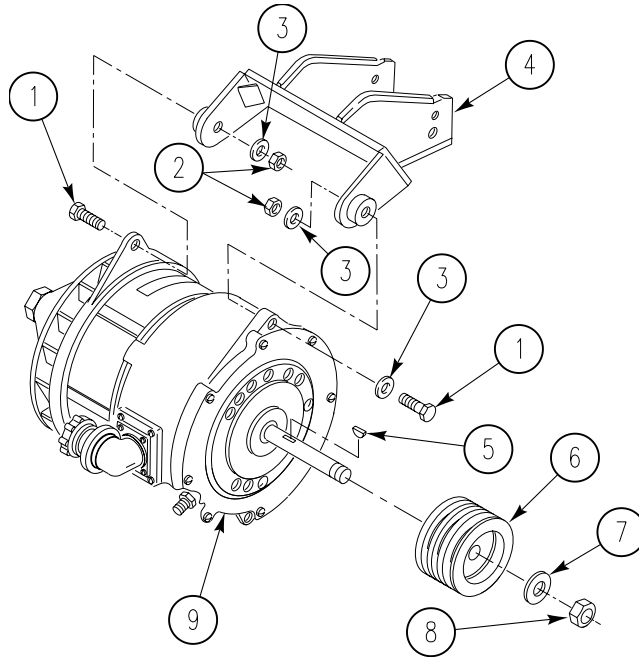

FOLLOW-THROUGH STEPS

1. Connect battery ground strap (WP 0337 00), (WP 0338 00), or (WP 0339 00).
2. Install power plant lower rear access panel (see your -10).
3. Install driver's power plant access panel (see your -10).

END OF TASK

ADJUST VOLTAGE REGULATOR

0256 00

THIS WORK PACKAGE COVERS:

Adjustment (page 0256 00-1)

INITIAL SETUP:

Maintenance Level

Unit

Tools and Special Tools

General Mechanic's Tool Kit (WP 0926 00, Item 65)
 Multimeter (WP 0926 00, Item 30)

Personnel Required

Unit Mechanic

References

See your -10
 TM 9-6140-200-14

Equipment Condition

Engine stopped (see your -10)
 Carrier blocked (see your -10)

ADJUSTMENT

NOTE

Check batteries to make sure they are fully charged. See TM 9-6140-200-14.

1. Remove access screw (1) from regulator (2).

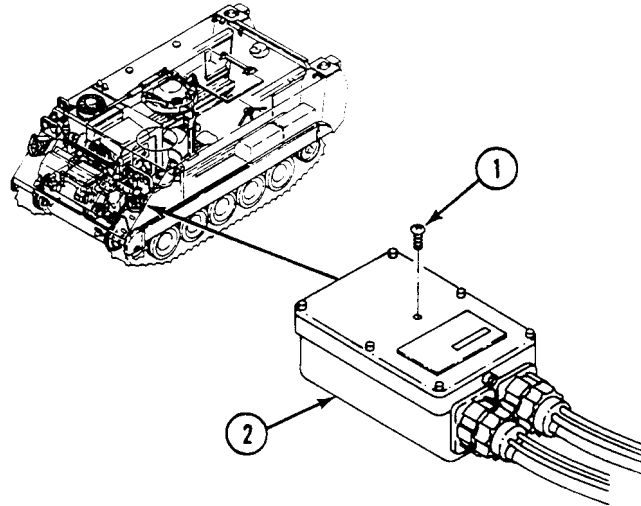

ADJUST VOLTAGE REGULATOR — Continued**0256 00**

2. Start engine (see your -10) and allow to run for about 20 minutes with service headlights on (see your -10).
3. Turn off service headlights (see your -10).
4. Set multimeter to read voltage on the 50 V dc scale.
5. Remove receptacle cap (3).
6. Place red lead (4) in positive socket of NATO plug (5) on auxiliary power (slave) receptacle (6). Touch negative lead (7) to outside of NATO plug (8) on receptacle.

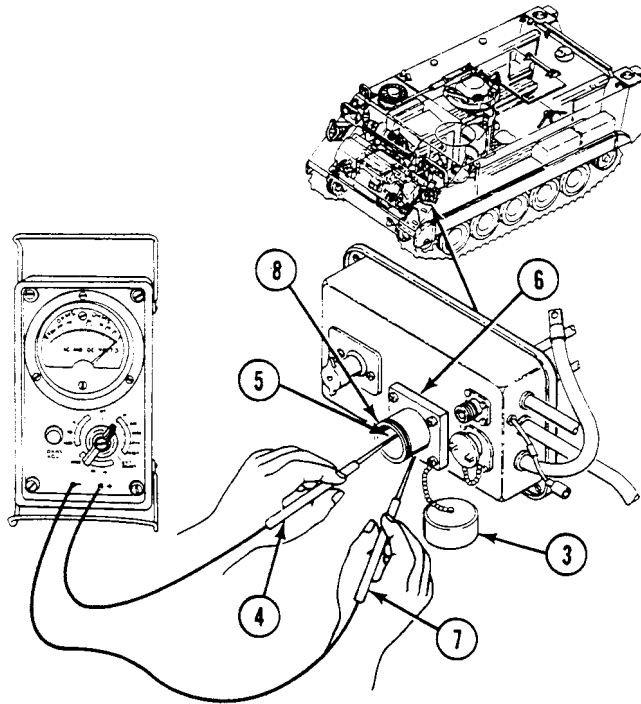

CAUTION

Battery can get overcharged and explode if the charging volts exceed 29. Adjust voltage regulator to 29 volts.

NOTE

Do not force adjusting screw past stop. If regulator cannot be adjusted, replace bad regulator (WP 0257 00).

Use insulated cross-tip screw driver #1 to adjust voltage.

7. With engine operating at 900 to 1100 rpm, turn adjusting screw (1) in regulator (2) until proper voltage reading is achieved.

90° and above:	27 V dc
50° thru 89°:	28 V dc
49° and below:	29 V dc

8. Install receptacle cap (3).

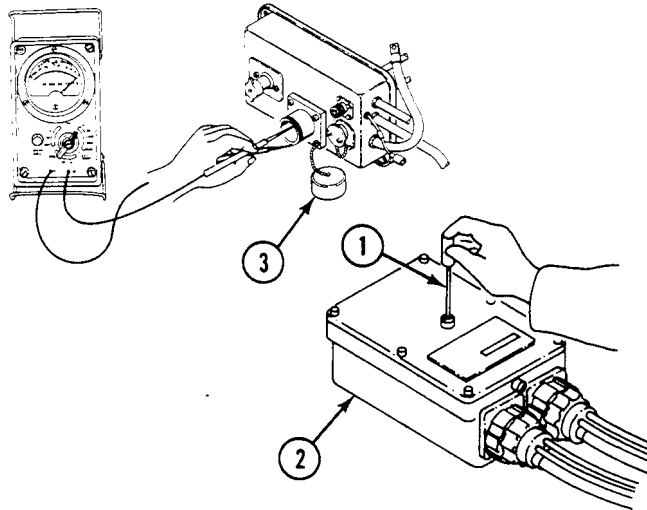

ADJUST VOLTAGE REGULATOR — Continued

0256 00

9. Stop engine (see your -10).
10. Install access screw (4) on regulator (5).

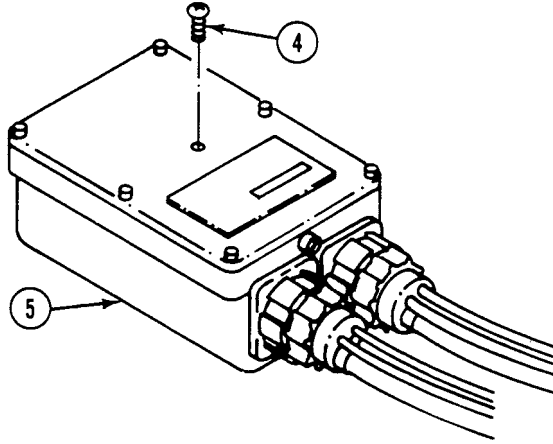
**END OF TASK**

REPLACE REGULATOR ASSEMBLY

0257 00

THIS WORK PACKAGE COVERS:

- Removal (page 0257 00-1).
 - Inspection and Repair (page 0257 00-2)
 - Installation (page 0257 00-3).
-

INITIAL SETUP:

Maintenance Level

Unit

Personnel Required

Unit Mechanic

Tools and Special Tools

General Mechanic's Tool Kit (WP 0926 00, Item 65)

References

See your -10

Materials/Parts

- Lockwasher (8)
- Lockwasher (8)
- Lockwasher

Equipment Condition

- Engine stopped (see your -10)
 - Carrier blocked (see your -10)
 - Battery ground strap disconnected (WP 0337 00), (WP 0338 00), or (WP 0339 00).
-

REMOVAL

1. Disconnect two cannon plugs (1) and (2) from regulator (3).

REPLACE REGULATOR ASSEMBLY — Continued**0257 00**

2. Remove four screws (4), eight lockwashers (5), ground strap (11), and mount plate (6) with attached regulator (3) from hull weldnuts. Discard lockwashers.
3. Remove four screws (7), eight lockwashers (8), and mount plate (6) from regulator (3). Discard lockwashers.
4. Remove nut (9), lockwasher (10), and ground strap (11) from regulator (3). Discard lockwasher.

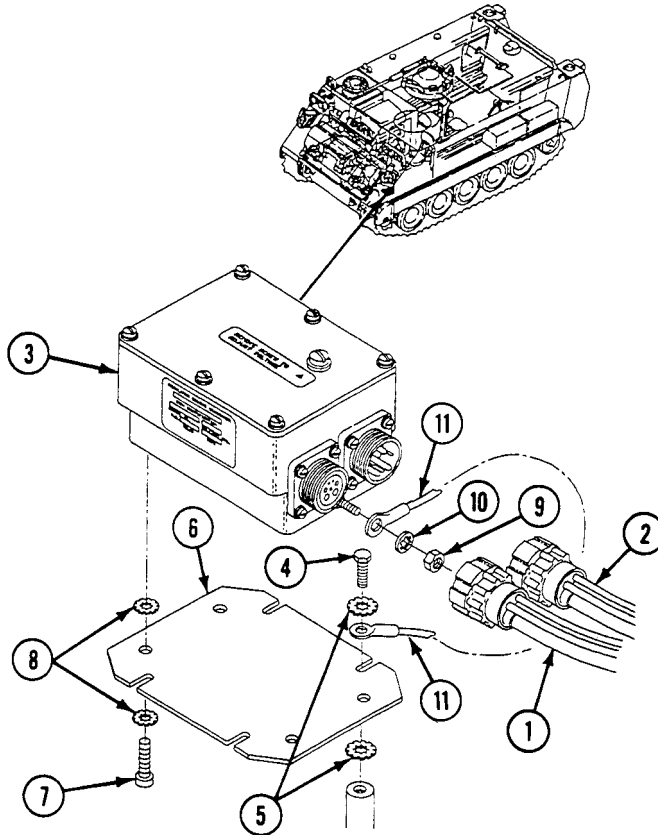
**INSPECTION-ACCEPTANCE AND REJECTION CRITERIA**

1. Check cables. Replace worn or cracked cables and damaged connectors (WP 0382 00)

INSTALLATION

1. Install ground strap (11), new lockwasher (10), and nut (9) on regulator (3).
2. Install mount plate (6) on regulator (3) with eight new lockwashers (8) and four screws (7).
3. Install mount plate (6) with regulator (3) and ground strap (11) on hull weldnuts with eight new lockwashers (5) and four screws (4).
4. Connect two cannon plugs (1) and (2) to regulator (3).

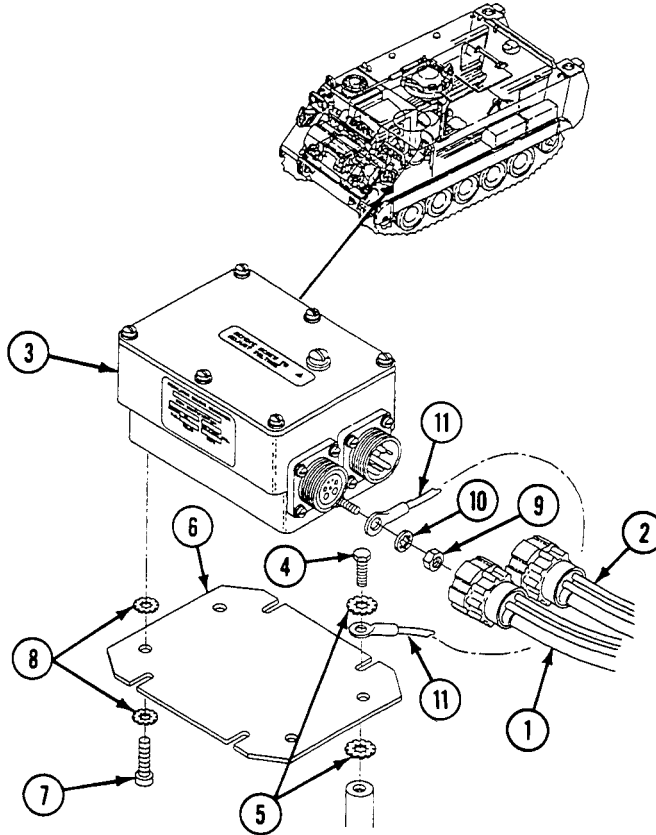

FOLLOW-THROUGH STEPS

1. Connect battery ground strap (WP 0337 00), (WP 0338 00), or (WP 0339 00).
2. Adjust regulator voltage (WP 0256 00).

END OF TASK

REPLACE STARTER RELAY SWITCH

0258 00

THIS WORK PACKAGE COVERS:

Removal (page 0258 00-2).
 Installation (page 0258 00-5).

INITIAL SETUP:

Maintenance Level

Unit

References

See your -10

Tools and Special Tools

General Mechanic's Tool Kit (WP 0926 00, Item 65)

Equipment Condition

Engine stopped (see your -10)
 Carrier blocked (see your -10)
 Driver's power plant access panel
 removed (see your -10)
 Battery ground strap disconnected (WP 0337 00),
 (WP 0338 00), or (WP 0339 00)
 Secondary fuel filter removed (WP 0202 00)

Materials/Parts

Locknut (2)
 Lockwasher

Personnel Required

Unit Mechanic

REMOVAL

1. Remove nut (1), lockwasher (2), two washers (9), and circuit lead 74A (3) from relay switch (4). Discard lockwashers.

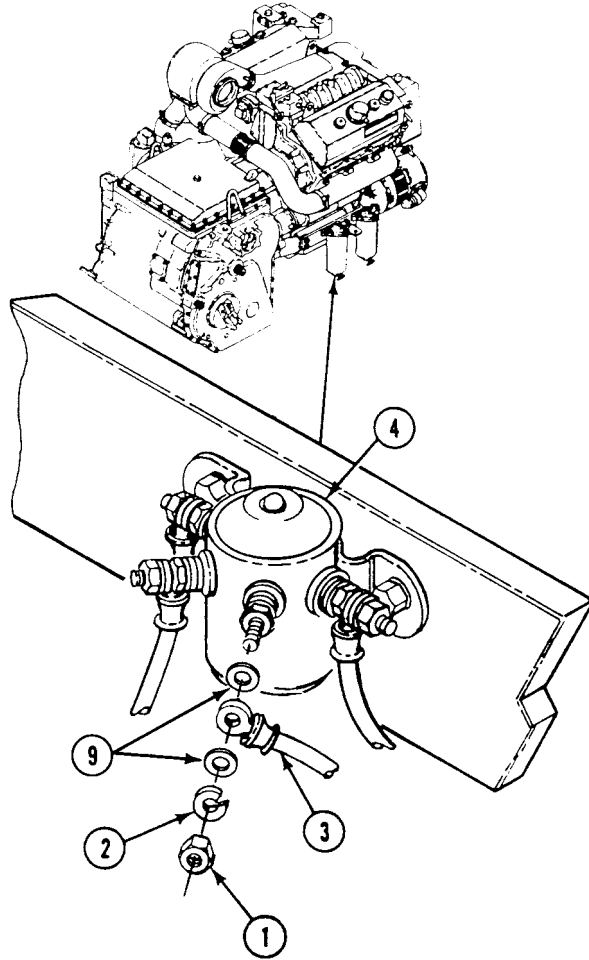

2. Remove nut (5), washer (6), lead 74A (3), and ground lead (7) from starter ground terminal (8).

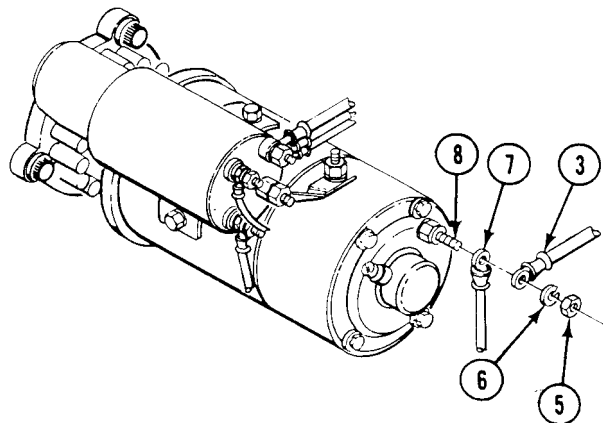

3. Remove nut (1), lockwasher (2), two washers (19), and circuit lead 74 (3) from relay switch (4). Discard lockwashers.
4. Remove nut (5), lockwasher (6), two washers (2), and circuit lead 74D (7) from relay switch (4). Discard lockwasher.

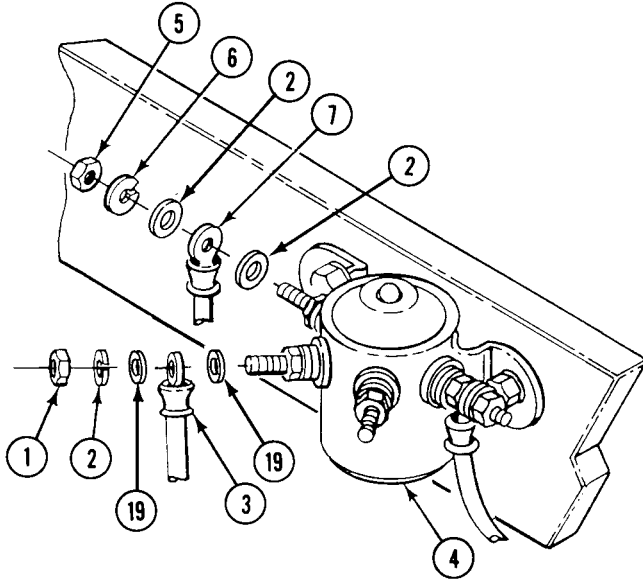

5. Remove nut (8), washer (9), and circuit lead 74D (7) from solenoid switch terminal (10).

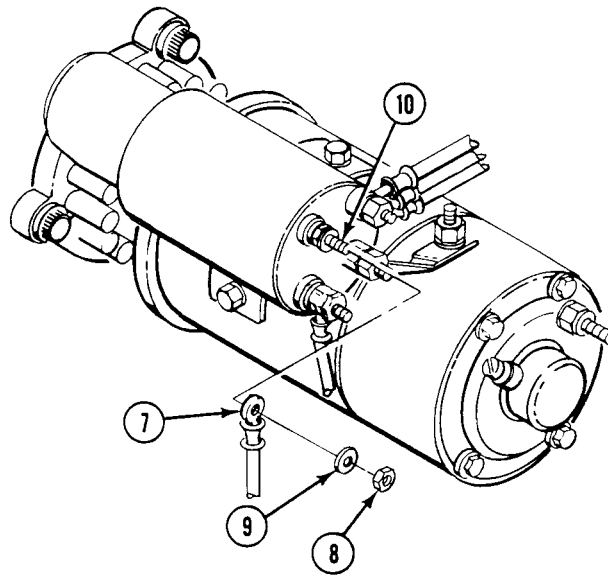

6. Remove nut (13), lockwasher (12), two washers (21), and circuit lead 74C (6) from relay switch (4). Discard lockwasher.

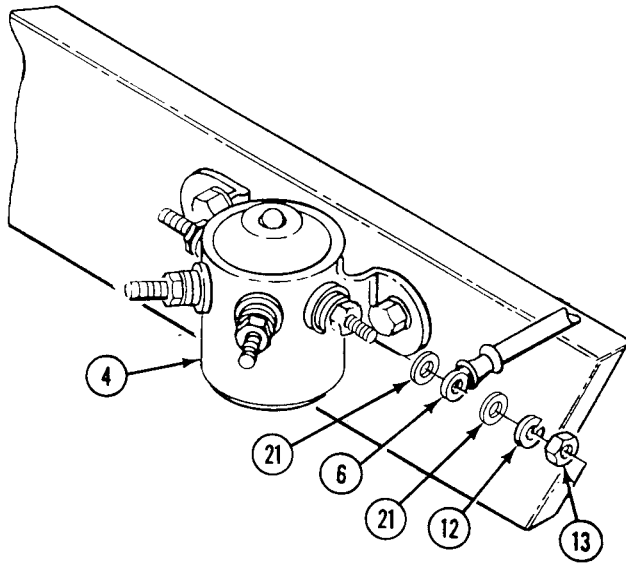

7. Remove nut (14), lockwasher (15), and circuit leads 74C (13), 6 (16), and 6A (17) from solenoid battery terminal (18). Discard lockwasher.

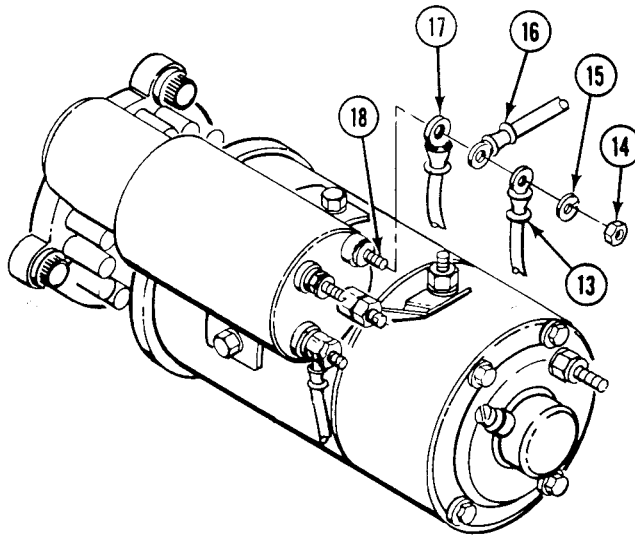

8. Remove two screws (1), washers (2), and locknuts (3) from starter relay switch (4) and bracket (5). Remove relay switch. Discard locknuts.

INSTALLATION

1. Position starter relay switch (4) on bracket (5). Secure relay with two screws (1), washers (2), and new locknuts (3).

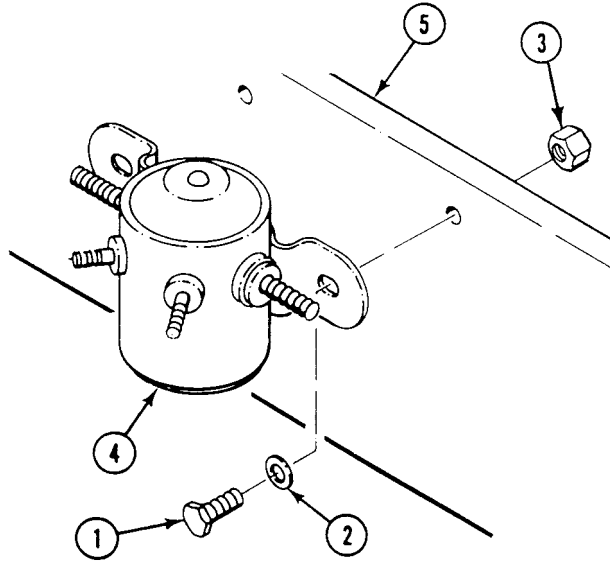

2. Install circuit leads 74C (6), 6 (7), and 6A (8), on starter solenoid battery terminal (9). Secure leads with new lockwasher (10) and nut (11).

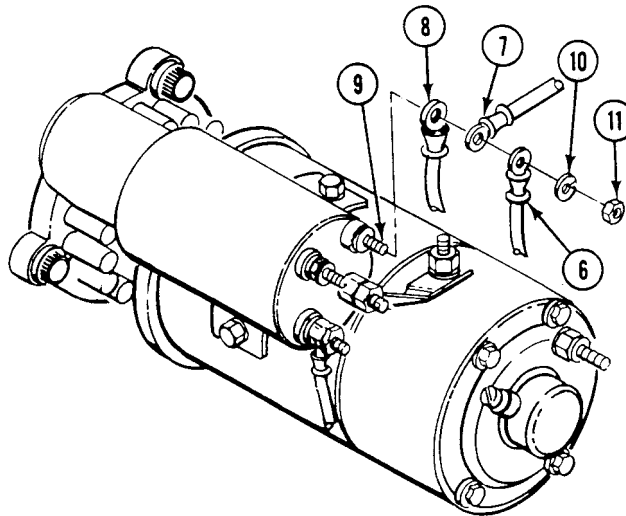

3. Install circuit lead 74C (6) on relay switch (4). Secure with new lockwasher (12), two washers (18), and nut (13).

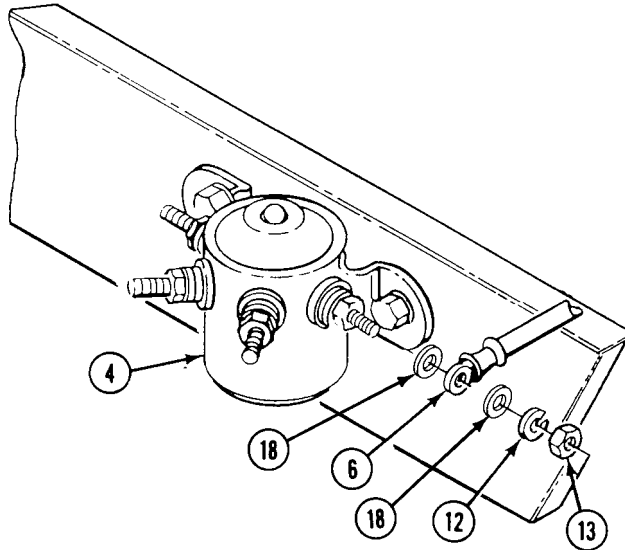

4. Install circuit lead 74D (14) on solenoid switch terminal (15). Secure lead with washer (16) and nut (17).

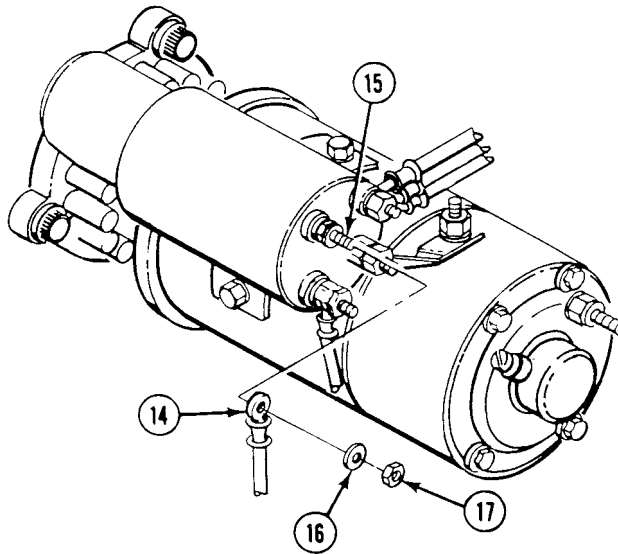

5. Install circuit lead 74D (1) on relay switch (2). Secure lead with nut (3) new lockwasher (4), and two washers (15).
6. Install circuit lead 74 (5) on relay switch (2). Secure lead with nut (6), new lockwasher (7), and two washers (16).

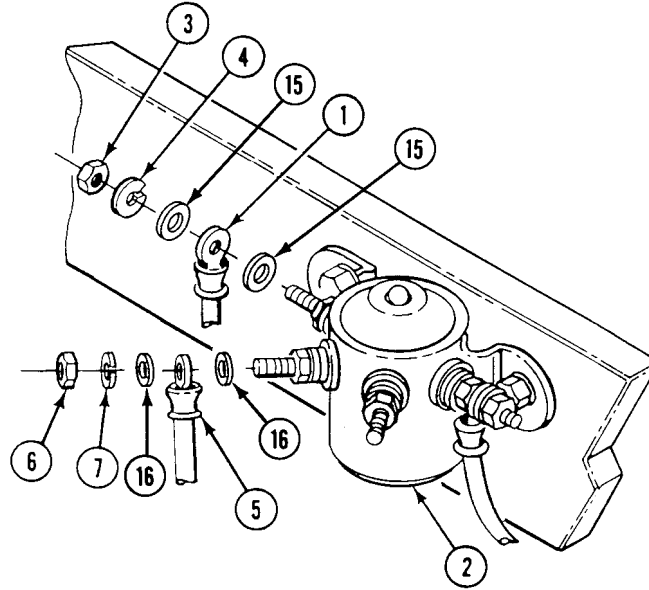

7. Install starter ground lead (8) and circuit lead 74A (9) on starter ground terminal (10). Secure leads with nut (11) and washer (12).

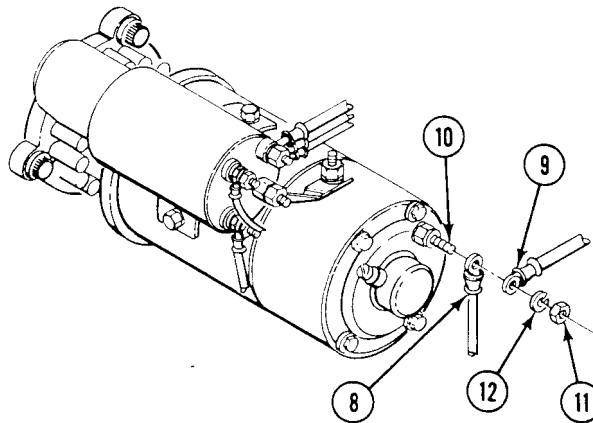

8. Install circuit lead 74A (9) on relay switch (2). Secure lead with nut (13), new lock washer (14), and two washers (17).

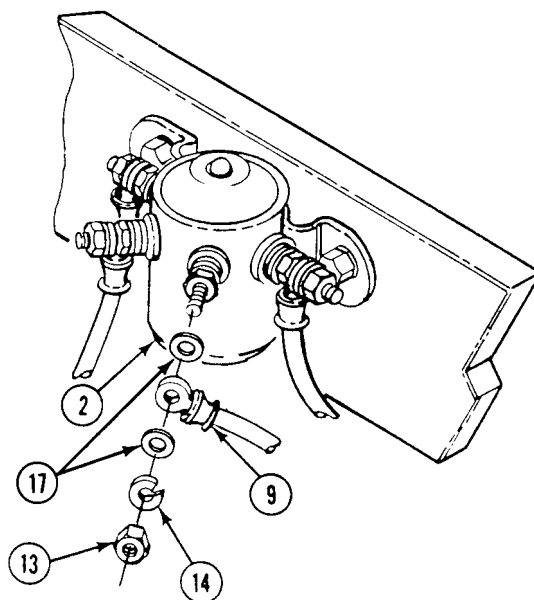

FOLLOW-THROUGH STEPS

1. Install secondary fuel filter (WP 0202 00).
2. Connect battery ground strap (WP 0337 00), (WP 0338 00), or (WP 0339 00).
3. Install driver's power plant access panel (see your -10).

END OF TASK

REPLACE STARTER

0259 00

THIS WORK PACKAGE COVERS:

Removal (page 0259 00-1).
 Installation (page 0259 00-2).

INITIAL SETUP:

Maintenance Level

Unit

References

See your -10

Tools and Special Tools

General Mechanic's Tool Kit (WP 0926 00, Item 65)
 Torque Wrench (WP 0926 00, Item 85)

Equipment Condition

Engine stopped (see your -10)
 Carrier blocked (see your -10)
 Battery ground strap disconnected (WP 0337 00),
 (WP 0338 00), or (WP 0339 00).
 Radiator drained (WP 0227 00)
 Driver's seat removed (WP 0551 00)
 Radiator outlet tube removed (WP 0233 00)
 Fuel filters and bracket removed (WP 0203 00)

Materials/Parts

Insulating compound (WP 0928 00, Item 38)
 Gasket
 Lockwasher (3)

Personnel Required

Unit Mechanic
 Helper (H)

REMOVAL

1. Remove nut (1), lockwasher (2), circuit 6 (3), circuit 6A (4), and 74C leads (5) from terminal (6) of starter solenoid (7).
2. Remove nut (8), lockwasher (9), circuit 74A (10), and ground lead (11) from lower terminal (12) of starter (13).

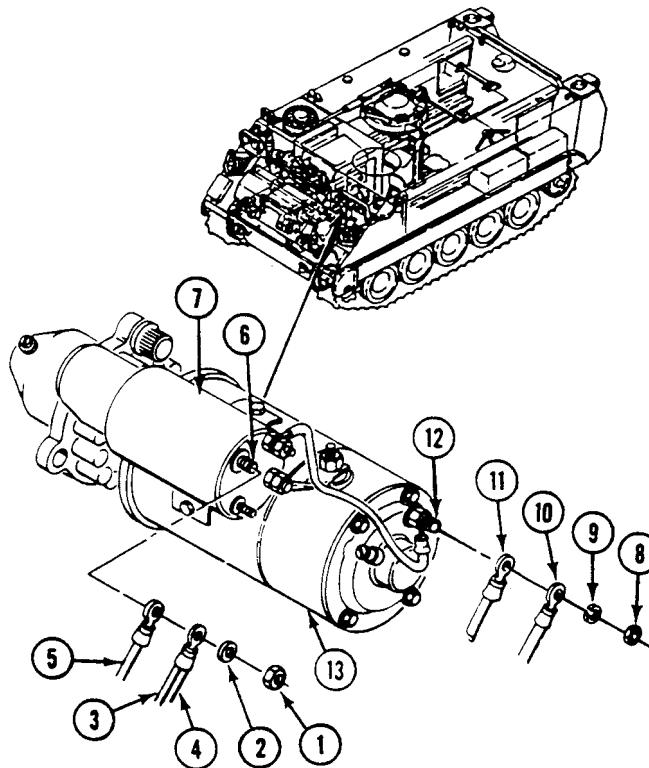

WARNING

Starter weighs 75 lbs (34 kg) and can cause back injury if handled improperly. Be sure to use a hoist or a helper to remove starter.

3. Remove three bolts (1), lockwashers (2), gasket (3), and starter (4) from engine. Discard gasket and lockwashers.

INSTALLATION

1. Apply thin coating of insulating compound to electrical connectors (5), and terminals (6) of starter (4).
2. Install new gasket (3) on starter (4). Install starter on engine. Secure with three bolts (1) and new lockwashers (2).
TIGHTEN BOLTS TO 137-147 LB-FT (186-198 N•m) TORQUE.

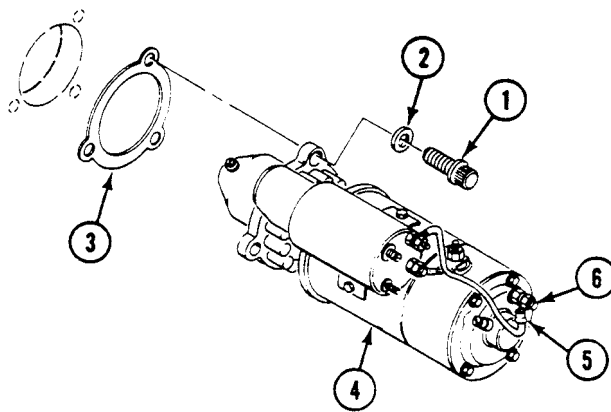

REPLACE STARTER — Continued**0259 00**

3. Install circuit 74A (7) and ground lead (8) on lower terminal (9) of starter (4). Secure with nut (10) and lockwasher (11).
4. Install circuit 6 and 6A leads (12), and 74C lead (13) on terminal (14) of starter solenoid (15). Secure with nut (16) and lockwasher (17).

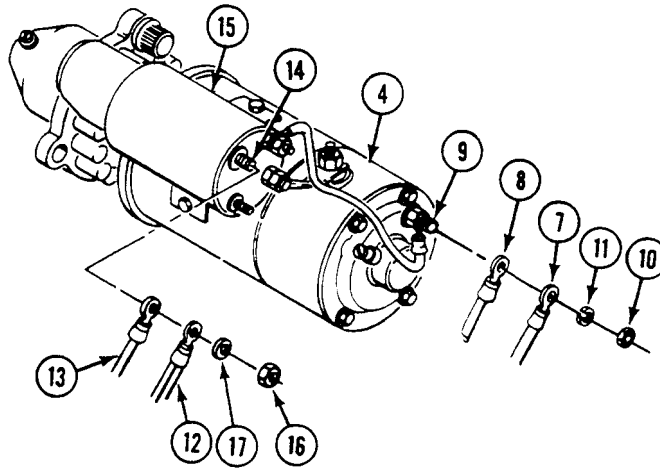
**FOLLOW-THROUGH STEPS**

1. Install fuel filters and bracket (WP 0203 00).
2. Install radiator outlet tube (WP 0233 00).
3. Install driver's seat (WP 0551 00).
4. Fill radiator (WP 0227 00).
5. Connect battery ground strap (WP 0337 00), (WP 0338 00), or (WP 0339 00).

END OF TASK

REPLACE MASTER SWITCH PANEL ASSEMBLY (M113A3, M1059A3, M1064A3, AND M58 ONLY)

0260 00 ■

THIS WORK PACKAGE COVERS:

Removal (page 0260 00-1).
 Installation (page 0260 00-4).

INITIAL SETUP:

Maintenance Level

Unit

Personnel Required

Unit Mechanic

Tools and Special Tools

General Mechanic's Tool Kit (WP 0926 00, Item 65)

References

See your -10

Materials/Parts

Grommet (3)
 Locknut
 Locknut (8)
 Lockwasher
 Lockwasher
 Lockwasher

Equipment Condition

Engine stopped (see your -10)
 Carrier blocked (see your -10)
 Battery ground strap disconnected (WP 0337 00)
 Infrared power supply cable disconnected from master switch panel (see your -10)
 Instrument warning light panel removed (WP 0288 00)

REPLACE MASTER SWITCH PANEL ASSEMBLY (M113A3, M1059A3, M1064A3, AND M58 ONLY) — Continued

0260 00

REMOVAL

1. Disconnect circuit 37 lead (1) from connector (2).
2. Remove eight locknuts (3), washers (4), screws (5), and master switch panel assembly (6) from distribution box (7). Discard locknuts.

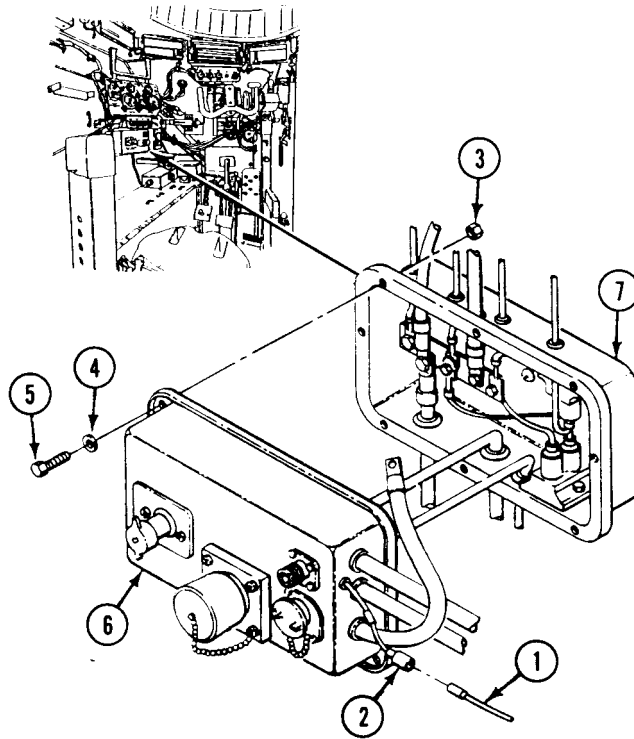

3. Remove screw (8), lockwasher (9), and ground lead (10) from negative post (11) of auxiliary power receptacle (12). Remove ground lead (10) and grommet (13) from master switch panel assembly (6). Discard lockwasher and grommet.

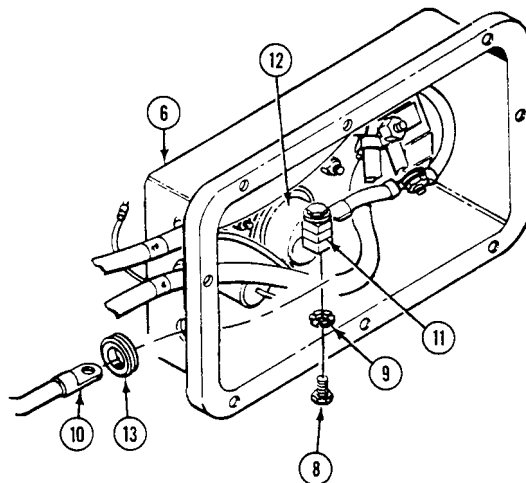

**REPLACE MASTER SWITCH PANEL ASSEMBLY (M113A3, M1059A3, M1064A3,
AND M58 ONLY) — Continued**

0260 00 ■

4. Remove screw (1), locknut (2), circuit 400 lead (3), circuit 2 lead (4), and circuit 6 lead (5) from conductor bus (6). Remove circuit 6 lead (5) and grommet (7) from master switch panel assembly (8). Discard locknut and grommet.
5. Remove nut (9), lockwasher (10), and circuit 2A lead (11) from master switch post (12). Discard lockwasher.

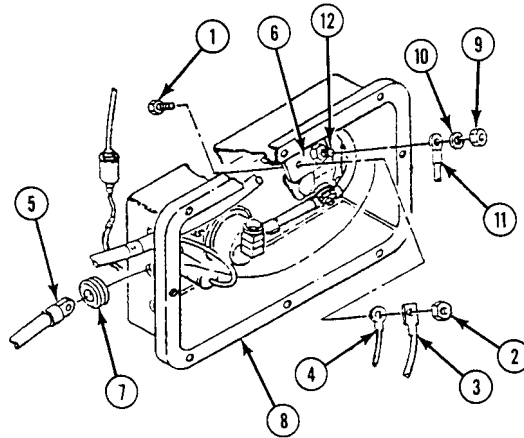

6. Remove screw (13), lockwasher (14), and circuit 49 lead (15) from bus bar (16) of distribution box (17). Remove circuit 49 lead (15) and grommet (18) from distribution box (17). Discard lockwasher and grommet.
7. Remove master switch panel assembly (8) from carrier.

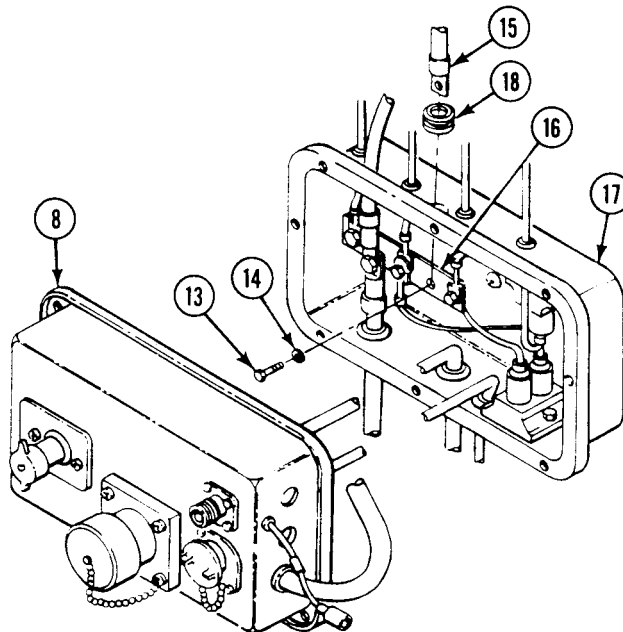

REPLACE MASTER SWITCH PANEL ASSEMBLY (M113A3, M1059A3, M1064A3, AND M58 ONLY) — Continued

0260 00

INSTALLATION

1. Install new grommet (18) on circuit 49 lead (15). Route lead into distribution box (17) and secure grommet.
2. Install circuit 49 lead (15) on bus bar (16). Secure with new lockwasher (14) and screw (13).

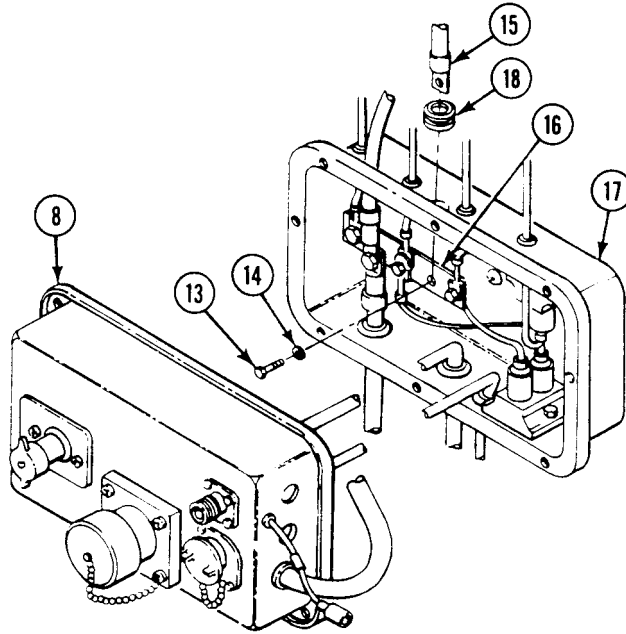

3. Install new grommet (7) on circuit 6 lead (5). Route lead into master switch panel assembly (8) and secure grommet.
4. Install circuit 6 lead (5), circuit 2 lead (3), and circuit 400 lead (4) on conductor bus (6). Secure with screw (1) and new locknut (2).
5. Install circuit 2A lead (11) on master switch post (12). Secure with new lockwasher (10) and nut (9).

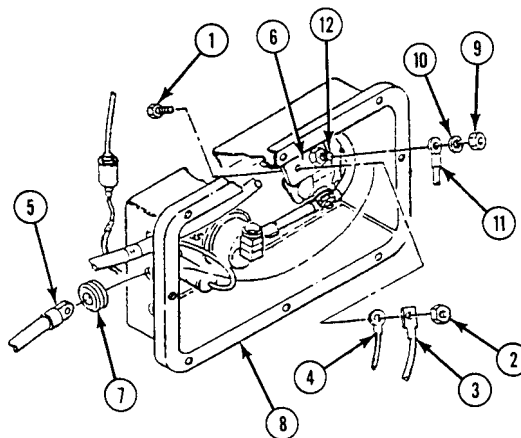

**REPLACE MASTER SWITCH PANEL ASSEMBLY (M113A3, M1059A3, M1064A3,
AND M58 ONLY) — Continued**

0260 00 ■

6. Install new grommet (1) on ground lead (2). Route ground lead into master switch panel assembly (3) and secure grommet.
7. Install ground lead (2) on negative post (4) of auxiliary power receptacle (5). Secure with screw (6) and new lockwasher (7).

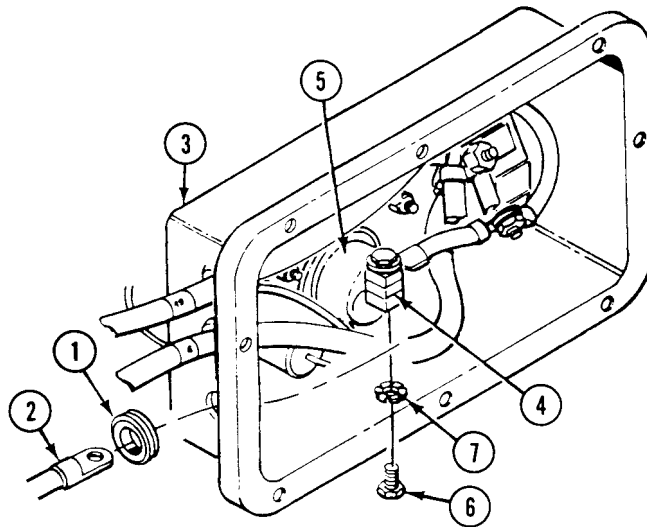

**REPLACE MASTER SWITCH PANEL ASSEMBLY (M113A3, M1059A3, M1064A3,
AND M58 ONLY) — Continued**

0260 00

8. Install master switch panel (3) on distribution box (8). Secure with eight screws (9), washers (10), and new locknuts (11).
9. Connect circuit 37 lead (12) to connector (13).

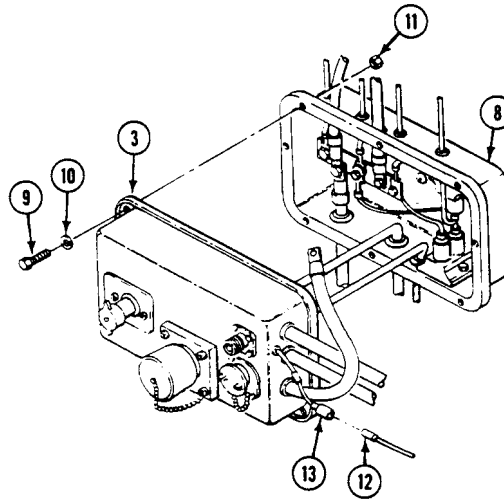
**FOLLOW-THROUGH STEPS**

1. Install instrument warning light panel (WP 0288 00).
2. Connect infrared power supply cable to dummy connector (see your -10).
3. Connect battery ground strap (WP 0337 00).
4. Turn MASTER SWITCH ON (see your -10).
5. Check that MASTER SWITCH ON indicator light comes on (see your -10).
6. Turn MASTER SWITCH OFF (see your -10).

END OF TASK

REPLACE MASTER SWITCH PANEL ASSEMBLY (M577A3 AND M1068A3 ONLY)

0261 00

THIS WORK PACKAGE COVERS:

Removal (page 0261 00-1).
 Installation (page 0261 00-4).

INITIAL SETUP:

Maintenance Level

Unit

Personnel Required

Unit Mechanic

Tools and Special Tools

General Mechanic's Tool Kit (WP 0926 00, Item 65)

References

See your -10

Materials/Parts

Grommet (11)
 Locknut (8)
 Lockwasher

Equipment Condition

Engine stopped (see your -10)
 Carrier blocked (see your -10)
 Battery ground lead disconnected (WP 0338 00)

REMOVAL

1. Remove eight locknuts (1), washers (2), and screws (3). Separate master switch panel assembly (4) from distribution box (5). Discard locknuts.
2. Disconnect wiring harness (6) leads (7)(8), and (9) from three circuit breakers (10)(11) and (12).
3. Remove nut (16), washer (17), and circuit 49 lead (13) from bottom terminal on master switch (14).
4. Remove circuit 49 lead (13) and grommet (15) from master switch panel assembly (4). Discard grommet.

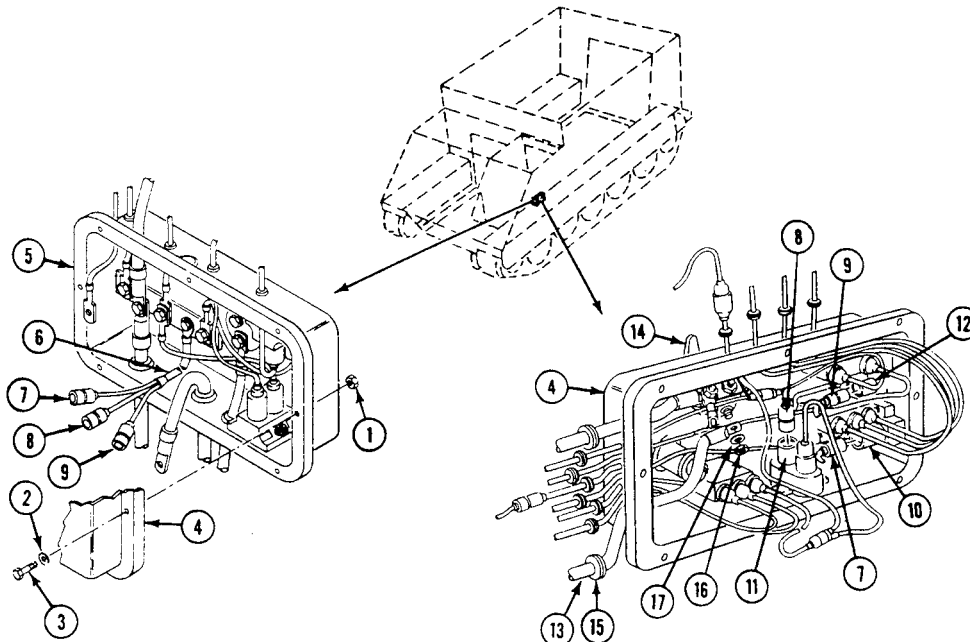

**REPLACE MASTER SWITCH PANEL ASSEMBLY (M577A3 AND M1068A3 ONLY) —
Continued**

0261 00

5. Remove nut (1), screw (2), and circuits 400 (3), 2 (4), and 6 (5) leads from bus bar (6).
6. Remove nut (7), lockwasher (8), and circuit 2A lead (9) from top terminal on master switch (10). Discard lockwasher.
7. Remove circuit 6 lead (5) and grommet (11) from master switch panel (12). Discard grommet.
8. Disconnect wiring harness (13) from circuit 38E (14). Disconnect circuit 10 lead (15) from circuit breaker (16). Disconnect circuit 10 lead connector (17) from dome light switch (18).
9. Remove wiring harness (13) and grommet (19) from master switch panel (12). Discard grommet.

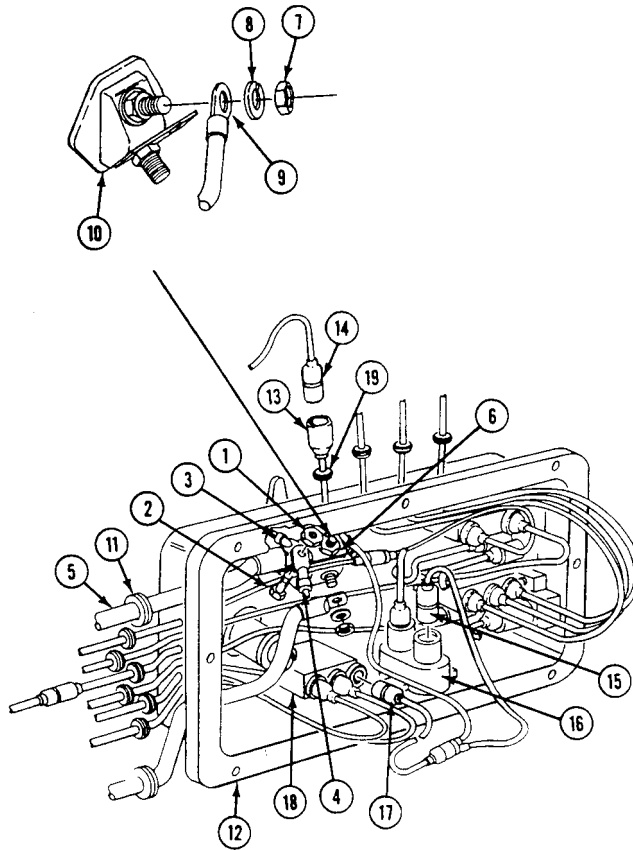

**REPLACE MASTER SWITCH PANEL ASSEMBLY (M577A3 AND M1068A3 ONLY) —
Continued**

0261 00

10. Disconnect wiring harness (20) from blower switch (21) and circuit 37B on circuit breaker (22).
11. Disconnect circuit 59 lead (23) from blower switch (21).
12. Remove circuit 59 lead (23), wiring harness (20), and two grommets (24) from master switch panel assembly (12). Discard grommets.
13. Disconnect utility outlet lead (25) from circuit 37 lead (26).
14. Disconnect circuit 37A lead (27) from circuit 37A lead on circuit breaker (28).

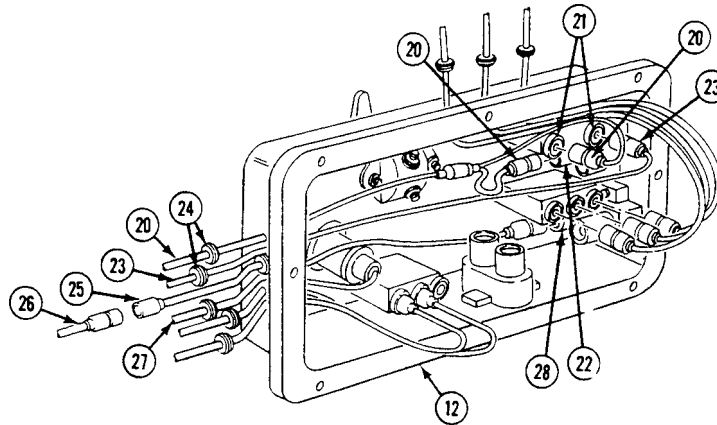

15. Disconnect circuits 38A lead (1) and 38 lead (2) from dome light switch (3).
16. Remove circuits 37A (4), 38 (2), 38A (1) leads and three grommets (5) from master switch panel (6). Discard grommets.
17. Disconnect circuits 28 (7), 29 (8), and 30 (9) leads from fuel selector switch (10).
18. Remove circuits 28 (7), 29 (8), and 30 (9) leads and three grommets (11) from master switch panel (6). Discard grommets.
19. Remove master switch panel assembly (6) from carrier.

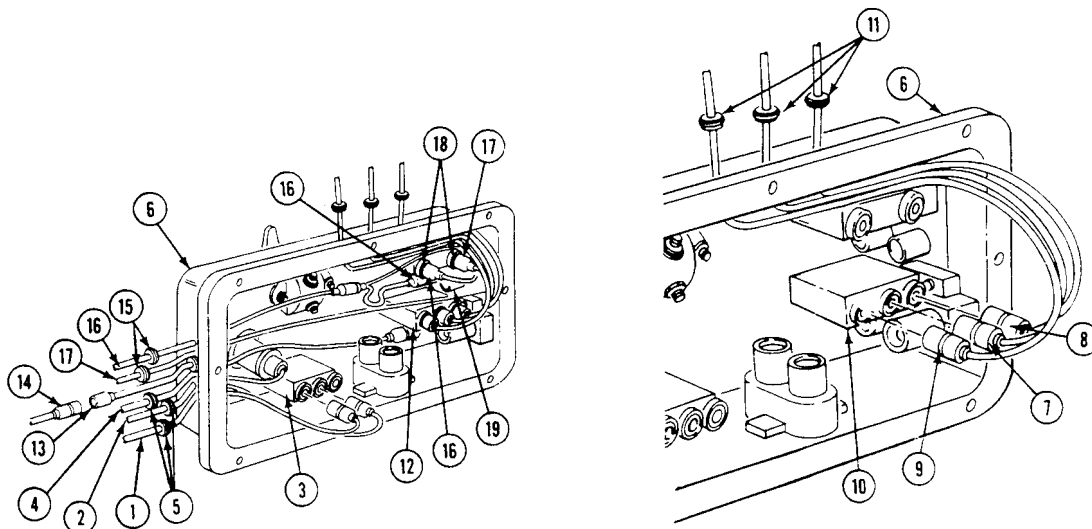

**REPLACE MASTER SWITCH PANEL ASSEMBLY (M577A3 AND M1068A3 ONLY) —
Continued**

0261 00

INSTALLATION

1. Install three new grommets (11) and circuits 28 (7), 29 (8), and 30 (9) leads in master switch panel (6).
2. Connect circuits 28 (7), 29 (8), and 30 (9) leads to fuel selector switch (10).
3. Install three new grommets (5) and circuits 37A (4), 38 (1), 38A (2) leads in master switch panel assembly (6).
4. Connect circuit 37A lead (4) to circuit breaker (12).
5. Connect circuits 38 (1), 38A (2) leads to dome light switch (3).
6. Connect utility outlet lead (13) to circuit 37 lead (14).
7. Install two new grommets (15), wiring harness (16), and circuit 59 lead (17) in master switch panel (6).
8. Connect wiring harness (16) to blower switch (18) and to circuit 37B lead on circuit breaker (19).
9. Connect circuit 59 lead (17) to blower switch (18).

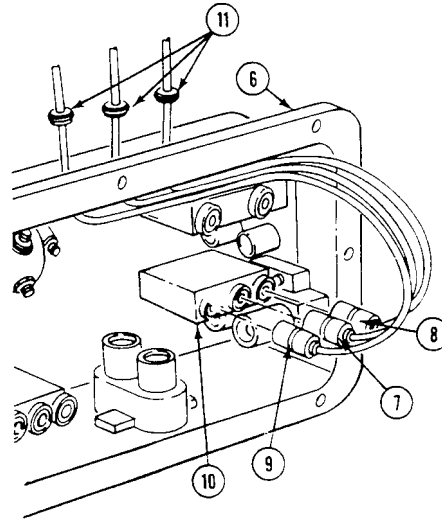
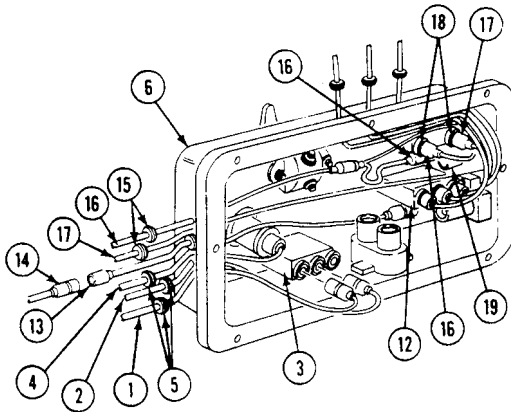

REPLACE MASTER SWITCH PANEL ASSEMBLY (M577A3 AND M1068A3 ONLY) —
Continued

0261 00

10. Install a new grommet (1) and wiring harness (2) in master switch panel (3).
11. Connect wiring harness (2) to circuit 38E lead (4). Connect circuit 10 lead (5) on circuit breaker (6). Connect circuit 10 lead (7) on dome light switch (8).
12. Install a new grommet (9) and circuit 6 lead (10) in master switch panel (3).
13. Install circuit 2A lead (11) on top terminal of master switch (12). Secure with new lockwasher (13) and nut (14).
14. Install circuits 6 (10), 2 (15), and 400 (16) leads on bus bar (17). Secure with screw (18) and nut (19).
15. Install new grommet (20) and circuit 49 lead (21) in master switch panel assembly (3).
16. Install circuit 49 lead (21) on bottom terminal of master switch (12). Secure with washer (22) and nut (23).

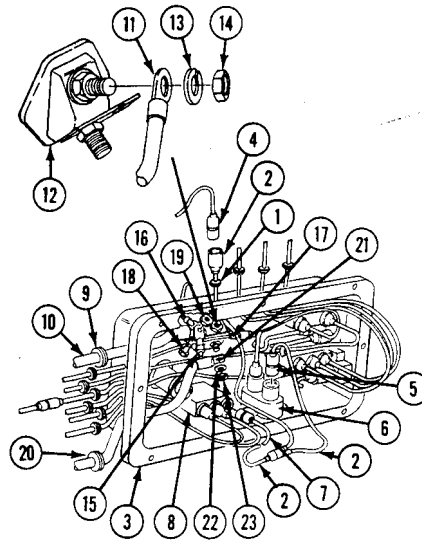

REPLACE MASTER SWITCH PANEL ASSEMBLY (M577A3 AND M1068A3 ONLY) —
Continued

0261 00

17. Connect wiring harness (24) leads (25) (26)(27) to three circuit breakers (28)(29)(30).
18. If damaged, replace gasket between master switch panel and distribution box (WP 0271 00).
19. Install master switch panel (3) on distribution box (31). Secure with eight screws (32), washers (33), and new locknuts (34).

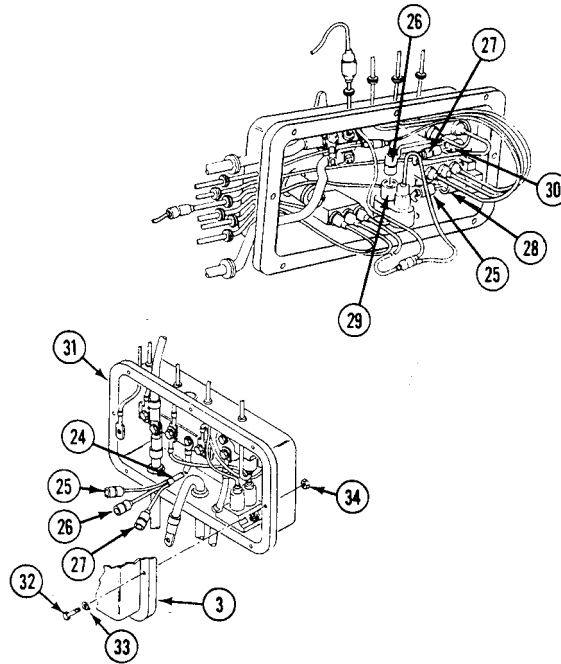
**FOLLOW-THROUGH STEPS**

1. Connect battery ground lead (WP 0338 00).
2. Start engine (see your -10). Check that master switch panel assembly is operable.
3. Stop engine (see your -10).

END OF TASK

REPLACE MASTER SWITCH (M113A3, M1059A3, M1064A3, AND M58 ONLY)

0262 00

THIS WORK PACKAGE COVERS:

Removal (page 0262 00-1).
 Installation (page 0262 00-2).

INITIAL SETUP:

Maintenance Level

Unit

References

See your -10

Tools and Special Tools

General Mechanic's Tool Kit (WP 0926 00, Item 65)

Equipment Condition

Engine stopped (see your -10)
 Carrier blocked (see your -10)
 Battery ground strap disconnected (WP 0337 00)
 Infrared power supply cable disconnected from master switch panel (see your -10)
 Warning light panel assembly removed (WP 0291 00)

Materials/Parts

Locknut (2)
 Locknut (8)
 Lockwasher (2)

Personnel Required

Unit Mechanic

REMOVAL

1. Disconnect circuit 37 lead (1) from connector (2) .
2. Remove eight locknuts (3) , washers (4) , screws (5) , and master switch panel (6) from distribution box (7) . Discard locknuts.

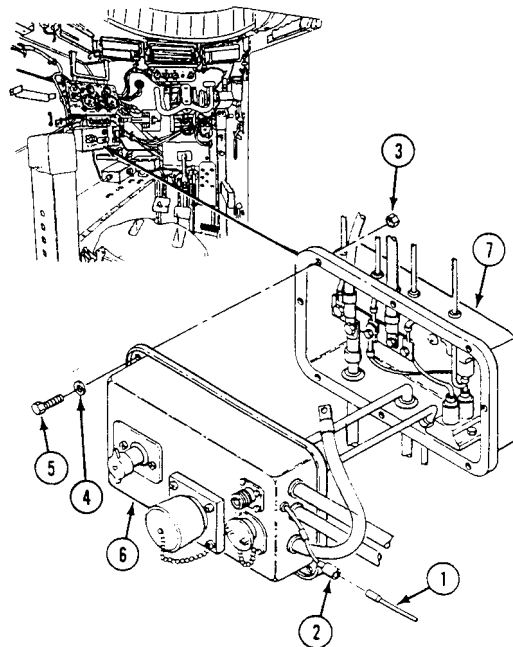

REPLACE MASTER SWITCH (M113A3, M1059A3, M1064A3, AND M58 ONLY) —
Continued

0262 00

3. Remove nut (8) , lockwasher (9) , circuit 50 lead (10) , and circuit 49 lead (11) from master switch terminal (12) . Discard lockwasher.
4. Remove nut (13) , lockwasher (14) , and conductor bus (15) with attached leads from master switch terminal (16) . Discard lockwasher.

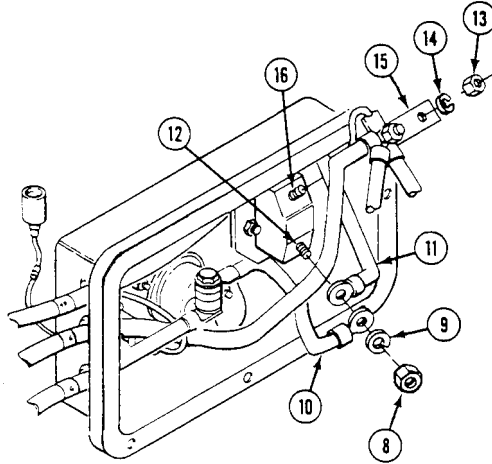

5. Remove screw (1) , washer (2) , and knob (3) from master switch (4) .
6. Remove two locknuts (5) , screws (6) , master switch (4) , and nameplate (7) from master switch panel (8) . Discard locknuts.

INSTALLATION

NOTE

Make sure nameplate is not installed upside down.

1. Align master switch (4) and nameplate (7) on master switch panel (8) . Secure with two screws (6) and new locknuts (5) .
2. Place knob (3) on master switch (4) . Secure with washer (2) and screw (1) .

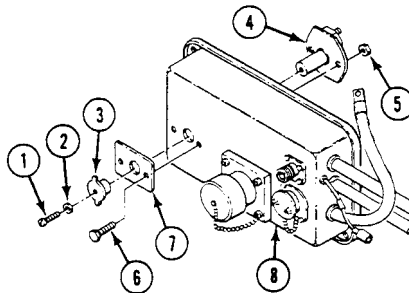

REPLACE MASTER SWITCH (M113A3, M1059A3, M1064A3, AND M58 ONLY) —
Continued

0262 00 ■

3. Install conductor bus (9) with attached leads on terminal (10) . Secure with new lockwasher (11) and nut (12) .
4. Install circuit 49 lead (13) and circuit 50 lead (14) on terminal (15) . Secure with new lockwasher (16) and nut (17) .

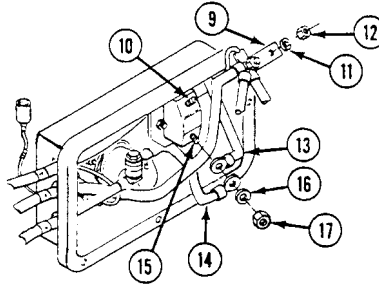

5. Install master switch panel (8) on distribution box (18) . Secure with eight screws (19) , washers (20) , and new locknuts (21) .
6. Connect circuit 37 lead (22) to connector (23) .

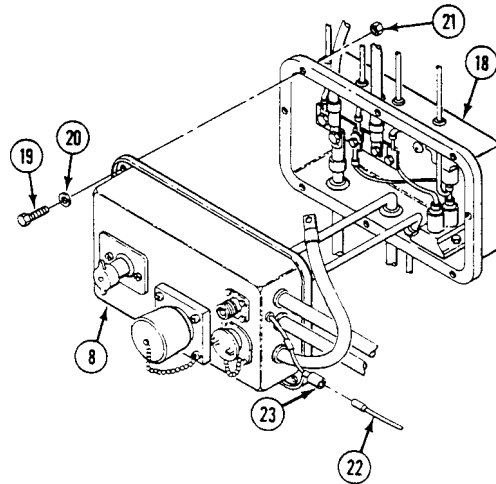

FOLLOW-THROUGH STEPS

1. Install warning light panel assembly(WP 0291 00).
2. Connect infrared power supply cable to dummy connector (see your -10).
3. Connect battery ground strap (WP 0337 00).
4. Turn MASTER SWITCH ON (see your -10).
5. Check that MASTER SWITCH ON indicator light comes ON (see your -10).
6. Turn MASTER SWITCH OFF (see your -10).

END OF TASK

REPLACE AUXILIARY POWER (SLAVE) RECEPTACLE (M113A3, M1059A3, M1064A3, AND M58 ONLY)

0263 00 ■

THIS WORK PACKAGE COVERS:

Removal (page 0263 00-1).
 Installation (page 0263 00-2).

INITIAL SETUP:

Maintenance Level
 Unit

References
 See your -10

Tools and Special Tools
 General Mechanic's Tool Kit (WP 0926 00, Item 65)

Equipment Condition

Materials/Parts

Locknut (4)
 Locknut (8)

Engine stopped (see your -10)
 Carrier blocked (see your -10)
 Battery ground strap disconnected (WP 0337 00)
 Warning light panel assembly removed (WP 0291 00)

Personnel Required
 Unit Mechanic

REMOVAL

1. Disconnect circuit 37 lead (1) from connector (2).
2. Remove eight locknuts (3), washers (4), screws (5), and master switch panel (6) from distribution box. Discard locknuts.
3. Remove screw (7), lockwasher (8), and circuit 50 lead (9) from positive post (10) of auxiliary power receptacle (11).
4. Remove screw (12), lockwasher (13), and ground strap (14) from negative post (15) of receptacle (11).
5. Remove four screws (16), washers (17), locknuts (18), and receptacle (11) from master switch panel (6). Discard locknuts.

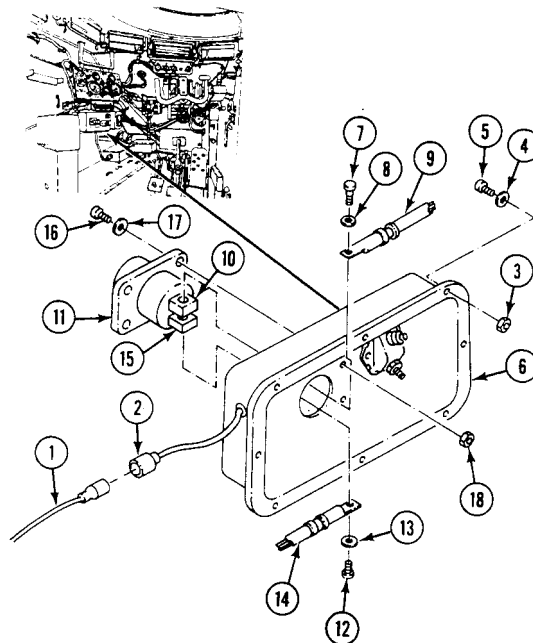

REPLACE AUXILIARY POWER (SLAVE) RECEPTACLE (M113A3, M1059A3, M1064A3, AND M58 ONLY) — Continued

0263 00

INSTALLATION**NOTE**

Make sure protective cap retaining cord is attached to receptacle lower mount screw.

1. Install receptacle (1) in master switch panel (2). Secure with four screws (3), washers (4), and new locknuts (5).
2. Install ground strap (6) on negative post (7) of receptacle (1). Secure with screw (8) and lockwasher (9).
3. Install circuit 50 lead (10) on positive post (11) of receptacle (1). Secure with screw (12) and lockwasher (13).
4. Install master switch panel (2) on distribution box. Secure with eight screws (14), washers (15), and new locknuts (16).
5. Connect circuit 37 lead (17) to connector (18).

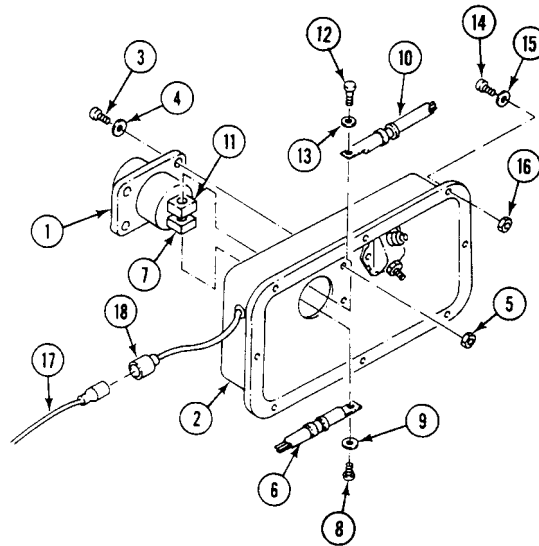
**FOLLOW-THROUGH STEPS**

1. Install warning light panel assembly (WP 0291 00).
2. Connect battery ground strap (WP 0337 00).

END OF TASK

REPLACE NATO AUXILIARY POWER (SLAVE) RECEPTACLE (M577A3 AND M1068A3 ONLY)

0264 00

THIS WORK PACKAGE COVERS:

- Removal (page 0264 00-1).
 - Installation (page 0264 00-3).
-

INITIAL SETUP:

Maintenance Level

Unit

Personnel Required

Unit Mechanic

Tools and Special Tools

- General Mechanic's Tool Kit (WP 0926 00, Item 65)
- Multimeter (WP 0926 00, Item 30)

References

See your -10

Materials/Parts

- Gasket
- Gasket
- Lockwashers (4)
- Lockwashers (4)
- Lockwashers (7)
- Lockwashers (2)

Equipment Condition

- Engine stopped (see your -10)
 - Carrier blocked (see your -10)
 - Battery ground lead disconnected (WP 0338 00)
-

REPLACE NATO AUXILIARY POWER (SLAVE) RECEPTACLE (M577A3 AND M1068A3 ONLY) — Continued

0264 00

REMOVAL

1. Remove seven screws (1), lockwashers (2), washers (3), and harness protector (4) from hull. Discard lockwashers.
2. Remove screw (5), washer (6), clamp (7), and circuit 50 lead (8) from hull weldnut.
3. Remove four screws (9), lockwashers (10), and washers (11) from receptacle (12). Discard lockwashers.
4. Pull receptacle (12) away from adapter (13).
5. Remove screw (14), lockwasher (15), and circuit 6 lead (16) from positive terminal of receptacle (12). Discard lockwasher.
6. Remove screw (17), lockwasher (18) and circuit 50 lead (8) from negative terminal of receptacle (12). Discard lockwasher.
7. Remove four screws (19), lockwashers (20), and washers (21) from adapter (13). Discard lockwashers.
8. Remove receptacle (12), gasket (22), insulator (23), adapter (13), and gasket (24) from hull. Discard gaskets.
9. Remove insulator bushing (25) from hull.

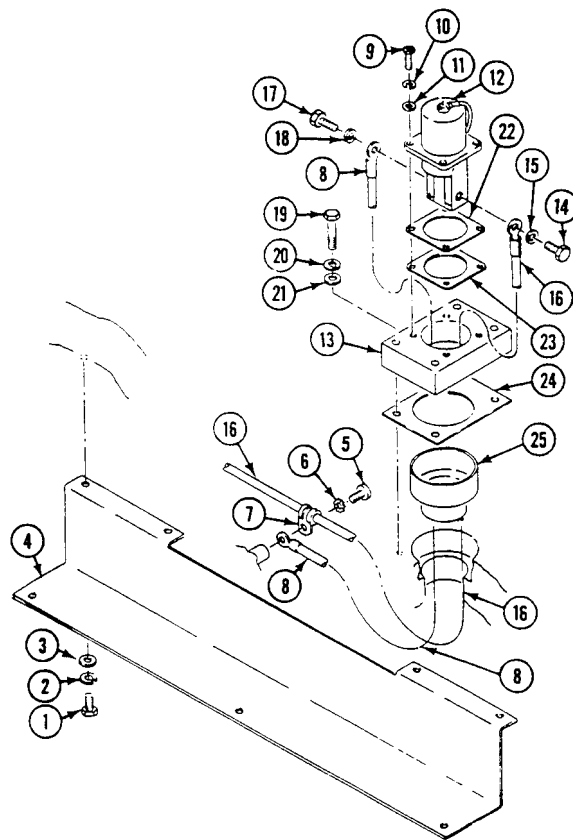

REPLACE NATO AUXILIARY POWER (SLAVE) RECEPTACLE (M577A3 AND M1068A3 ONLY) — Continued

0264 00

INSTALLATION

1. Install insulator bushing (1) in hull.
2. Install receptacle (2), new gasket (3), insulator (4), adapter (5), and new gasket (6).
3. Connect circuit 6 lead (7) to positive terminal of receptacle (2) with new lockwasher (8) and screw (9).
4. Connect circuit 50 lead (10) to negative terminal of receptacle (2) with new lockwasher (11) and screw (12).
5. Position new gasket (6) and adapter (5) on hull and secure with four screws (13), new lockwashers (14), and washers (15).
6. Align receptacle (2), new gasket (3), and insulator (4) with adapter (5). Install four screws (16), new lockwashers (17), and washers (18).
7. Place circuit 50 lead (10) and clamp (19) on hull weldnut. Secure with washer (20) and screw (21).
8. Position harness protector (22) and secure with seven screws (23) new lockwashers (24), and washers (25).

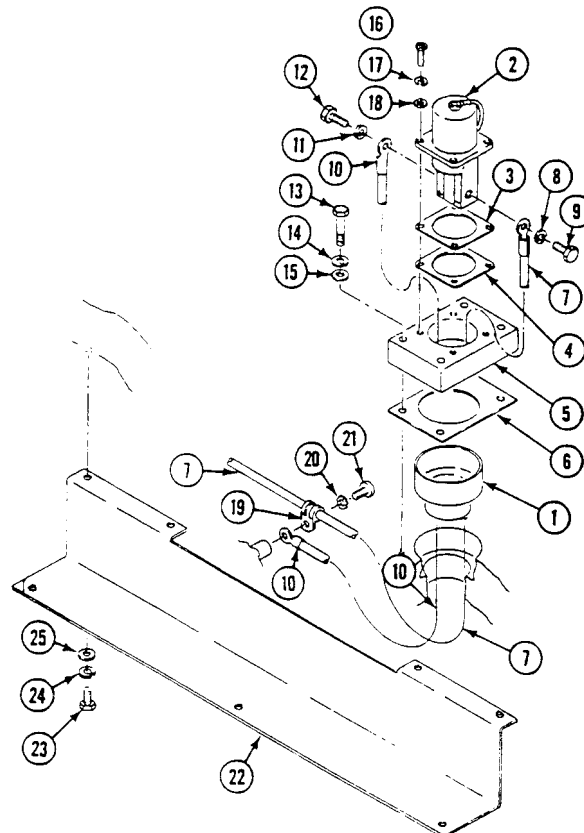

FOLLOW-THROUGH STEPS

1. Connect battery ground lead (WP 0338 00).

END OF TASK

REPLACE UTILITY OUTLET RECEPTACLE

0265 00

THIS WORK PACKAGE COVERS:

- Removal (page 0265 00-1).
- Inspection and Repair (page 0265 00-2).
- Installation (page 0265 00-2).

INITIAL SETUP:

Maintenance Level

Unit

References

See your -10

Tools and Special Tools

- General Mechanic's Tool Kit (WP 0926 00, Item 65)
- Multimeter (WP 0926 00, Item 30)

Equipment Condition

- Engine stopped (see your -10)
- Carrier blocked (see your -10)
- Battery ground lead disconnected (WP 0337 00) or (WP 0338 00)
- Warning light panel assembly removed (WP 0291 00)

Materials/Parts

- Locknut (8)
- Lockwashers (2)

Personnel Required

Unit Mechanic

REMOVAL

1. Disconnect circuit 37 lead (1) from utility outlet receptacle lead (2).
2. Slide shell connector (3) down lead (2). Remove slotted washer (4) from lead. Remove shell connector from lead.
3. Remove eight locknuts (5), washers (6), screws (7) and master switch panel (8) from distribution box (9). Discard locknuts.

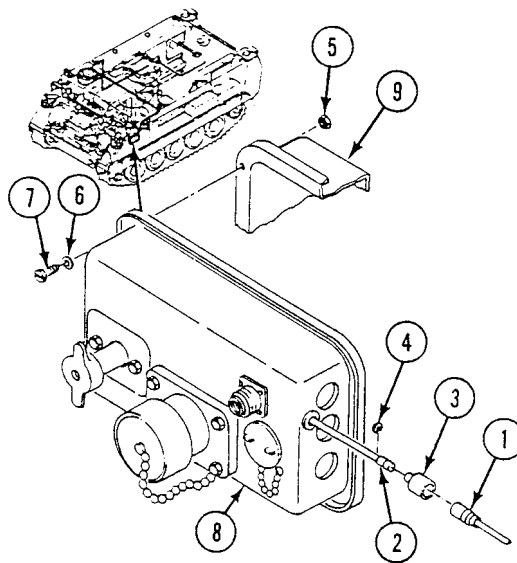

4. Remove two screws (10), lockwashers (11), and receptacle (12) from master switch panel (8). Discard lockwashers.
5. If needed, remove grommet (13) from master switch panel (8).

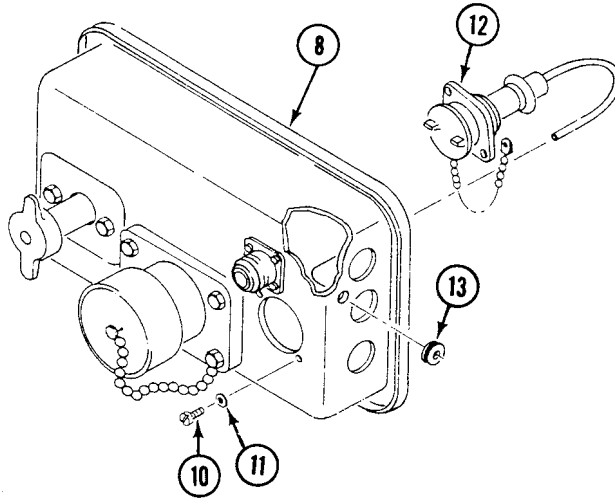

INSPECTION-ACCEPTANCE AND REJECTION CRITERIA

1. Check connectors. Replace cracked or broken connector (WP 0382 00).

INSTALLATION

1. If removed, install new grommet (1) from master switch panel (2).

NOTE

Make sure receptacle cover retaining chain is installed on lower screw.

2. Place utility outlet receptacle (3) on rear of panel (2). Secure with two new lockwashers (4) and screws (5).
3. Route utility outlet receptacle lead (6) through grommet (1). Install shell connector (7) and slotted washer (8).

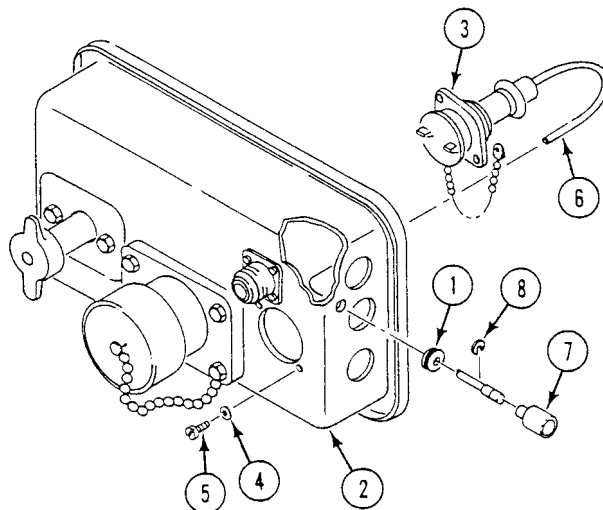

REPLACE UTILITY OUTLET RECEPTACLE — Continued**0265 00** ■

4. Install master switch panel (2) on distribution box (9) Secure with eight screws (10), washers (11), and new locknuts (12).
5. Connect circuit 37 lead (13) to utility receptacle lead (6).

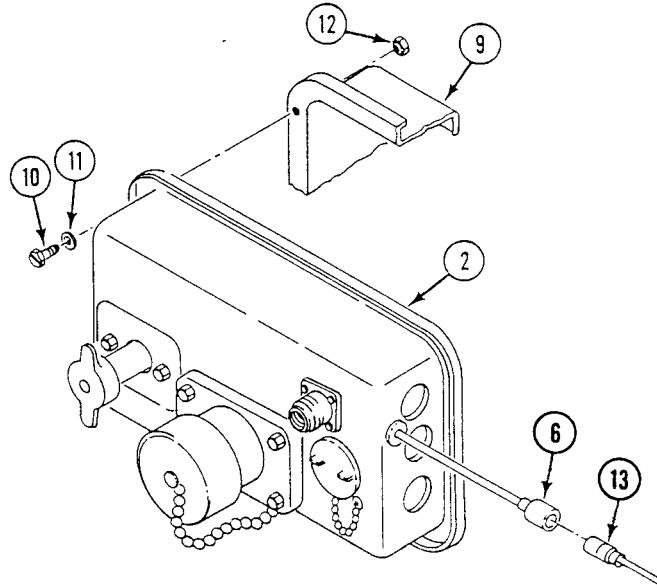
**FOLLOW-THROUGH STEPS**

1. Install warning light panel assembly (WP 0291 00).
2. Connect battery ground lead (WP 0337 00) or (WP 0338 00).
3. Turn MASTER SWITCH to ON (see your -10).
4. Check receptacle for electrical continuity.
5. Turn MASTER SWITCH to OFF (see your -10).

END OF TASK

**REPLACE MASTER SWITCH TO DISTRIBUTION BOX LEAD (CIRCUIT 49)
(M113A3, M1059A3, M1064A3, AND M58 ONLY)**

0266 00

THIS WORK PACKAGE COVERS:

- Removal (page 0266 00-1).
- Inspection and Repair (page 0266 00-2).
- Installation (page 0266 00-3).

INITIAL SETUP:

Maintenance Level

Unit

Personnel Required

Unit Mechanic

Tools and Special Tools

- General Mechanic's Tool Kit (WP 0926 00, Item 65)
- Multimeter (WP 0926 00, Item 30)

References

See your -10

Materials/Parts

- Grommet (2)
- Locknut (8)
- Lockwasher
- Lockwasher

Equipment Condition

- Engine stopped (see your -10)
- Carrier blocked (see your -10)
- Battery ground strap disconnected (WP 0337 00)
- Instrument warning light panel removed (WP 0288 00)

REMOVAL

1. Remove eight locknuts (1), washers (2), screws (3), and master switch panel (4) from distribution box (5). Discard locknuts.

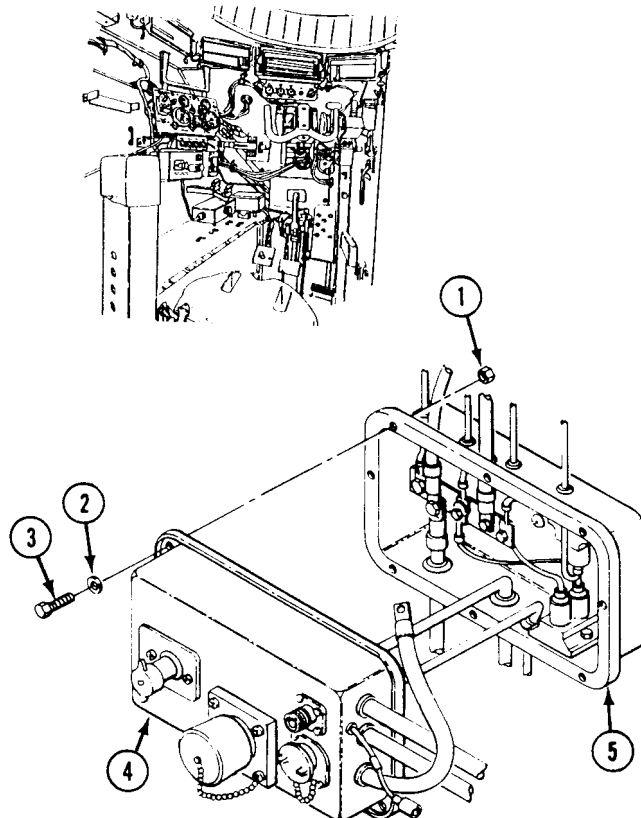

REPLACE MASTER SWITCH TO DISTRIBUTION BOX LEAD (CIRCUIT 49) (M113A3, M1059A3, M1064A3, AND M58 ONLY) — Continued

0266 00

2. Remove nut (6), lockwasher (7), circuit 49 lead (8), and circuit 50 lead (9) from master switch terminal (10). Discard lockwasher.
3. Remove screw (11), lockwasher (12), and circuit 49 lead (8) from bus bar (13) of distribution box (5). Discard lockwasher.

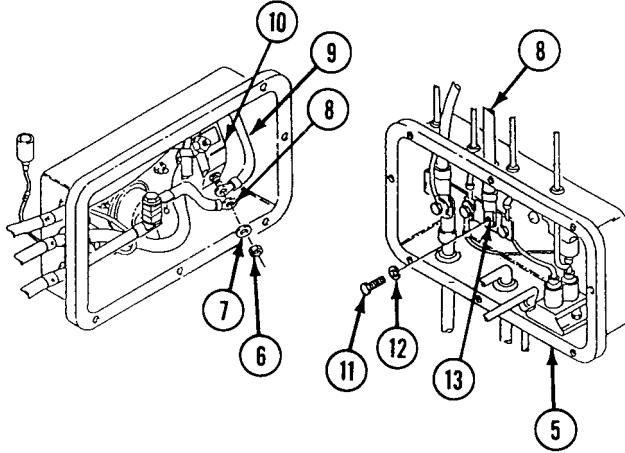

4. Remove circuit 49 lead (1) with two grommets (2) from master switch panel (3) and distribution box (4).

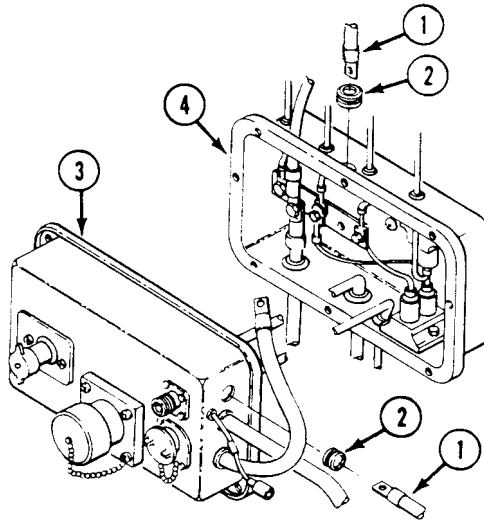

INSPECTION-ACCEPTANCE AND REJECTION CRITERIA

1. Check circuit 49 lead for continuity. Replace bad lead.

REPLACE MASTER SWITCH TO DISTRIBUTION BOX LEAD (CIRCUIT 49) (M113A3, M1059A3, M1064A3, AND M58 ONLY) — Continued

0266 00

INSTALLATION

1. Install two grommets (2) on circuit 49 lead (1).
2. Route circuit 49 lead (1) through distribution box (4) and master switch panel (3). Install grommets (2) in box and panel.

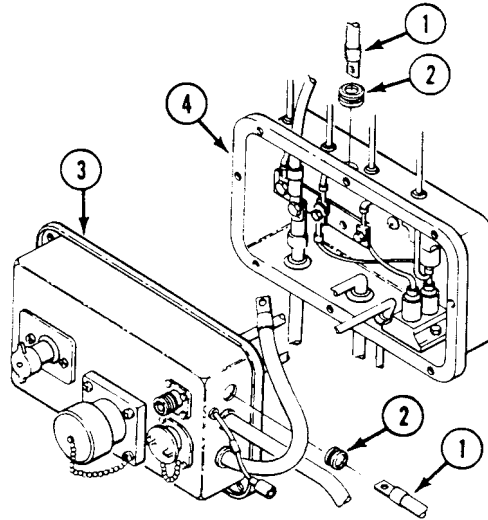

REPLACE MASTER SWITCH TO DISTRIBUTION BOX LEAD (CIRCUIT 49) (M113A3, M1059A3, M1064A3, AND M58 ONLY) — Continued

0266 00

3. Install circuit 49 lead (1) on bus bar (5) of distribution box (4). Secure with new lockwasher (6) and screw (7).
4. Install circuit 49 lead (1) and circuit 50 lead (8) on master switch terminal (9). Secure with nut (10) and new lockwasher (11).
5. Install master switch panel (3) on distribution box (4). Secure with eight screws (12), washers (13), and new locknuts (14).

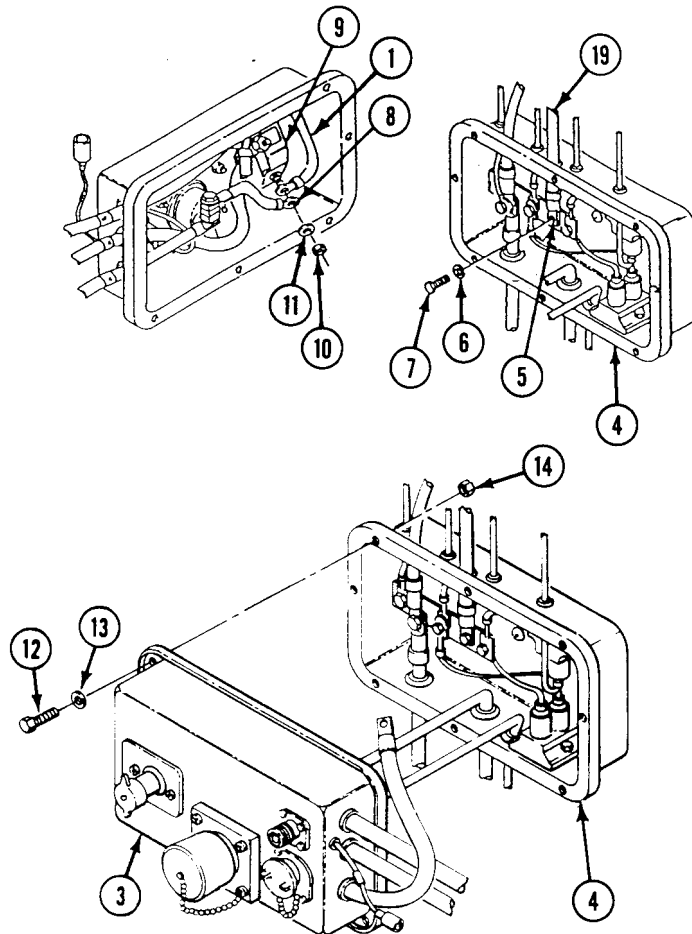
**FOLLOW-THROUGH STEPS**

1. Install instrument warning light panel (WP 0288 00).
2. Connect battery ground strap (WP 0337 00).
3. Turn MASTER SWITCH ON (see your -10).
4. Check that MASTER SWITCH ON indicator light comes on (see your -10).
5. Turn MASTER SWITCH OFF (see your -10).

END OF TASK

**REPLACE MASTER SWITCH TO DISTRIBUTION BOX LEAD (CIRCUIT 49)
(M577A3 AND M1068A3 ONLY)**

0267 00

THIS WORK PACKAGE COVERS:

- Removal (page 0267 00-1).
- Inspection and Repair (page 0267 00-2).
- Installation (page 0267 00-3).

INITIAL SETUP:

Maintenance Level

Unit

Personnel Required

Unit Mechanic

Tools and Special Tools

- General Mechanic's Tool Kit (WP 0926 00, Item 65)
- Multimeter (WP 0926 00, Item 30)

References

See your -10

Materials/Parts

- Grommet (2)
- Lockwasher
- Locknut (8)
- Locknut

Equipment Condition

- Engine stopped (see your -10)
- Carrier blocked (see your -10)
- Battery ground lead disconnected (WP 0338 00)

REMOVAL

1. Remove eight locknuts (1), washers (2), screws (3), and master switch panel (4) from distribution box (5). Discard locknuts.
2. Remove locknut (6), washer (7), and circuit 49 lead (8) from master switch terminal (9). Discard locknut.

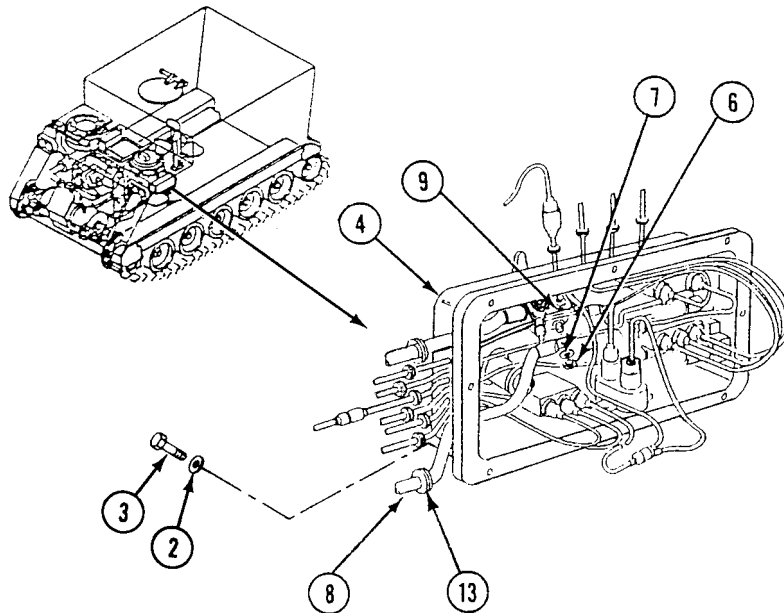

REPLACE MASTER SWITCH TO DISTRIBUTION BOX LEAD (CIRCUIT 49) (M577A3 AND M1068A3 ONLY) — Continued

0267 00

3. Remove screw (10), lockwasher (11), and circuit 49 lead (8) from distribution box bus bar (12). Discard lockwasher.
4. Remove circuit 49 lead (8) with two grommets (13) from master switch panel (4) and distribution box (5). Discard grommets.

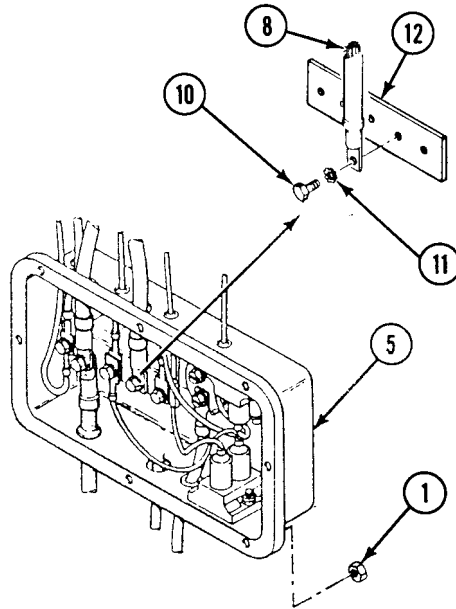
**INSPECTION-ACCEPTANCE AND REJECTION CRITERIA**

1. Check circuit 49 lead for continuity. Replace bad lead.

REPLACE MASTER SWITCH TO DISTRIBUTION BOX LEAD (CIRCUIT 49) (M577A3 AND M1068A3 ONLY) — Continued

0267 00

INSTALLATION

1. Install two new grommets (1) on circuit 49 lead (2).
2. Route circuit 49 lead (2) through distribution box (3) and master switch panel (4). Install new grommets (1) in box and panel.
3. Install circuit 49 lead (2) on bus bar (5) of distribution box (3). Secure with new lockwasher (6) and screw (7).
4. Install circuit 49 lead (2) on master switch terminal (8). Secure with washer (9), and new locknut (10).
5. Install master switch panel (4) on distribution box (3). Secure with eight screws (11), washers (12), and new locknuts (13).

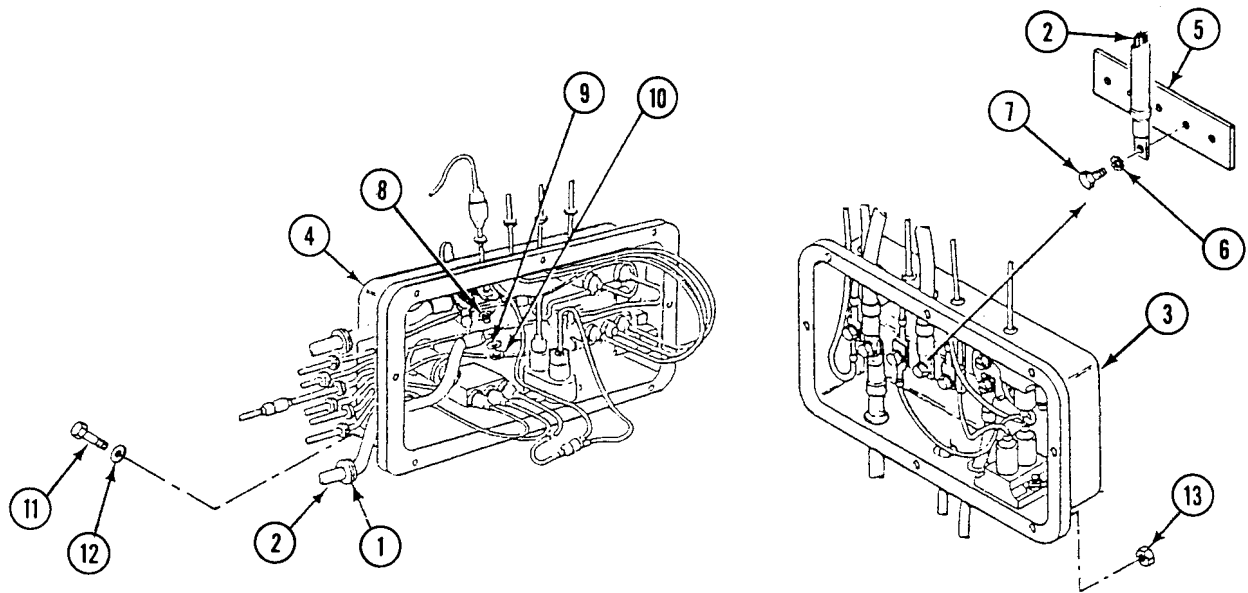

FOLLOW-THROUGH STEPS

1. Connect battery ground lead (WP 0338 00).
2. Turn MASTER SWITCH ON (see your -10).
3. Check that MASTER SWITCH light comes on (see your -10).
4. Turn MASTER SWITCH OFF (see your -10).

END OF TASK

**REPLACE MASTER SWITCH TO AUXILIARY POWER RECEPTACLE LEAD
(CIRCUIT 50) (M113A3, M1059A3, M1064A3, AND M58)**

0268 00

THIS WORK PACKAGE COVERS:

- Removal (page 0268 00-1).
- Inspection and Repair (page 0268 00-2).
- Installation (page 0268 00-3).

INITIAL SETUP:

Maintenance Level

Unit

References

See your -10

Tools and Special Tools

- General Mechanic's Tool Kit (WP 0926 00, Item 65)
- Multimeter (WP 0926 00, Item 30)

Equipment Condition

- Engine stopped (see your -10)
- Carrier blocked (see your -10)
- Battery ground strap disconnected (WP 0337 00)
- Warning light panel assembly removed (WP 0291 00)

Materials/Parts

- Locknut (9)
- Lockwasher (2)

Personnel Required

Unit Mechanic

REMOVAL

1. Remove eight locknuts (1), washers (2), screws (3) and master switch panel (4) from distribution box (5). Discard locknuts.

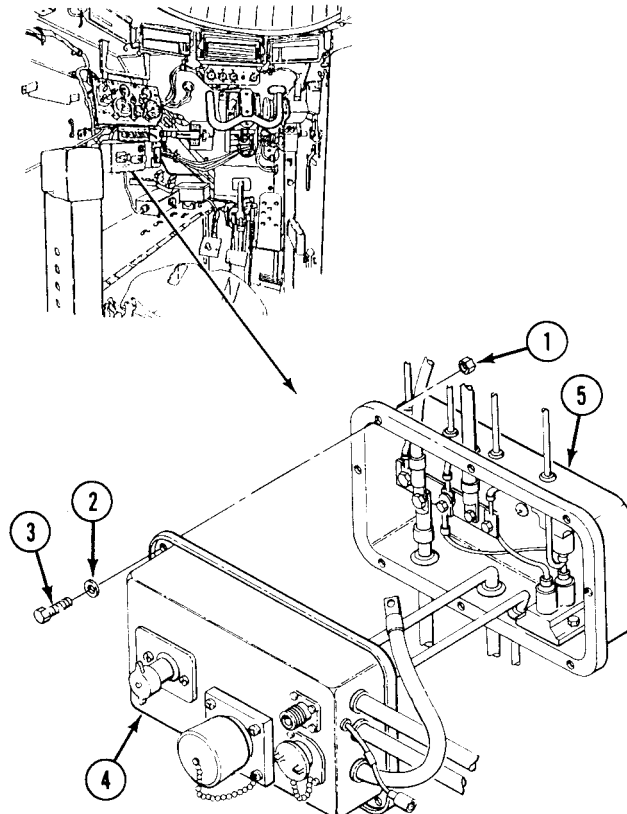

REPLACE MASTER SWITCH TO AUXILIARY POWER RECEPTACLE LEAD (CIRCUIT 50)**0268 00****■ (M113A3, M1059A3, M1064A3, AND M58) — Continued**

2. Remove locknut (6) and lockwasher (7) from circuit 50 lead (8) and circuit 49 lead (9) on master switch terminal (10). Discard locknut and lockwasher.
3. Remove screw (11), lockwasher (12) and circuit 50 lead (8) from positive terminal (13) of auxiliary power receptacle (14). Remove lead from master switch panel (4). Discard lockwasher.

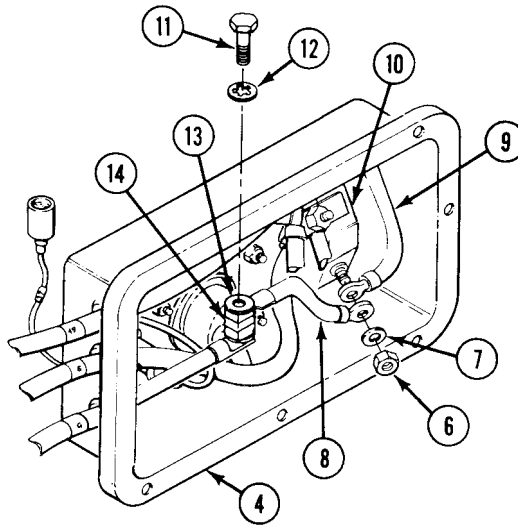
**INSPECTION-ACCEPTANCE AND REJECTION CRITERIA**

1. Check circuit 50 lead for continuity. Replace bad lead.

**REPLACE MASTER SWITCH TO AUXILIARY POWER RECEPTACLE LEAD (CIRCUIT 50)
(M113A3, M1059A3, M1064A3, AND M58) — Continued**

0268 00

INSTALLATION

1. Install circuit 50 lead (1) on positive terminal (2) of auxiliary power receptacle (3). Secure with screw (4) and new lockwasher (5).
2. Install circuit 50 lead (1) and circuit 49 lead (6) on master switch terminal (7). Secure with new lockwasher (8) and new locknut (9).

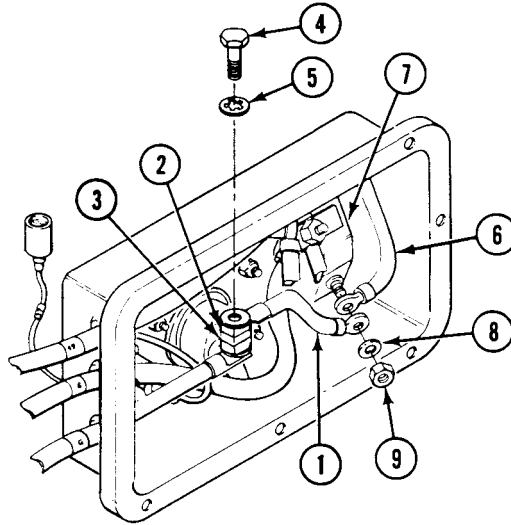

REPLACE MASTER SWITCH TO AUXILIARY POWER RECEPTACLE LEAD (CIRCUIT 50)**0268 00****(M113A3, M1059A3, M1064A3, AND M58) — Continued**

3. Install master switch panel (10) on distribution box (11) Secure with eight screws (12), washers (13) and new locknuts (14).

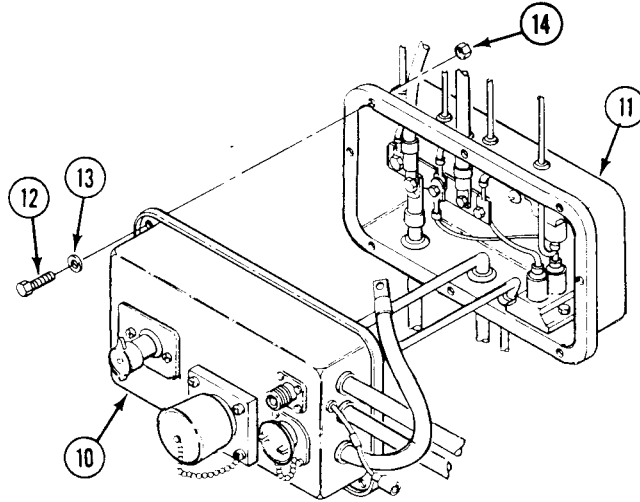
**FOLLOW-THROUGH STEPS**

1. Install warning light panel assembly (WP 0291 00).
2. Connect battery ground strap (WP 0337 00).
3. Turn MASTER SWITCH to ON (see your -10).
4. Check to see if MASTER SWITCH LIGHT comes on (see your -10).
5. Turn MASTER SWITCH to OFF (see your -10).

END OF TASK

**REPLACE DISTRIBUTION BOX (M113A3, M1059A3, M1064A3,
AND M58 ONLY)**

0269 00 ■

THIS WORK PACKAGE COVERS:

Removal (page 0269 00-2).
Installation (page 0269 00-4).

INITIAL SETUP:

Maintenance Level

Unit

References

See your -10

Tools and Special Tools

General Mechanic's Tool Kit (WP 0926 00, Item 65)

Equipment Condition

Engine stopped (see your -10)

Materials/Parts

Lockwasher (5)

Lockwasher (3)

Carrier blocked (see your -10)

Personnel Required

Unit Mechanic

Battery ground strap disconnected (WP 0337 00)

Master switch panel assembly removed (WP 0260 00)

■ REPLACE DISTRIBUTION BOX (M113A3, M1059A3, M1064A3, AND M58 ONLY)
— Continued

0269 00

REMOVAL

1. Remove screw (1), lockwasher (2), leads 27E, 10, 15, (3), and 450A (4) from bus bar (5) of distribution box (6). Remove grommet (7). Discard lockwasher and grommet.
2. Remove lead 400 (8) from distribution box (6).
3. Remove circuit leads 2 (9), 2A (10), and two grommets (11) from distribution box (6). Discard grommets.

NOTE

Step 4 applies to M113A3 carriers with water/ration heater kit installed only.

4. Remove circuit lead 222B (12) and grommet (13) from distribution box (6). Discard grommet.

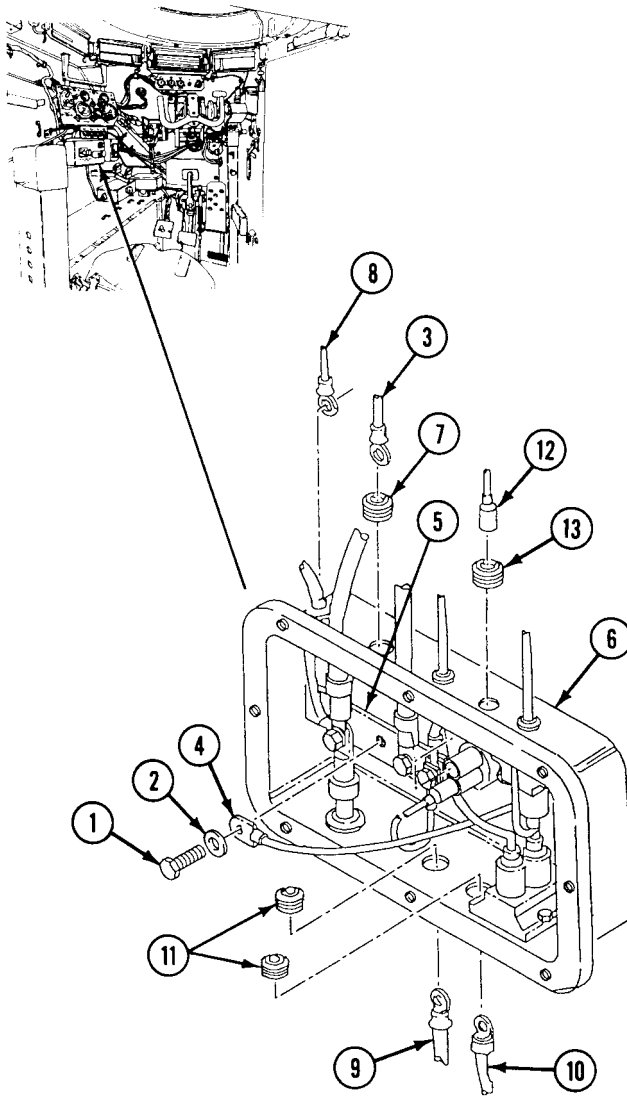

REPLACE DISTRIBUTION BOX (M113A3, M1059A3, M1064A3, AND M58 ONLY)

0269 00 ■

— Continued

5. Remove two screws (1), lockwashers (2), circuit leads 6 (3), 6A (4), 6L (5), 49 (6), and four grommets (7) from distribution box (8). Discard lockwashers and grommets.
6. Remove circuit leads 450 (9), 450B (10), and two grommets (11). Discard grommets.
7. Remove five screws (12), lockwashers (13), and distribution box (8) from hull. Discard lockwashers.

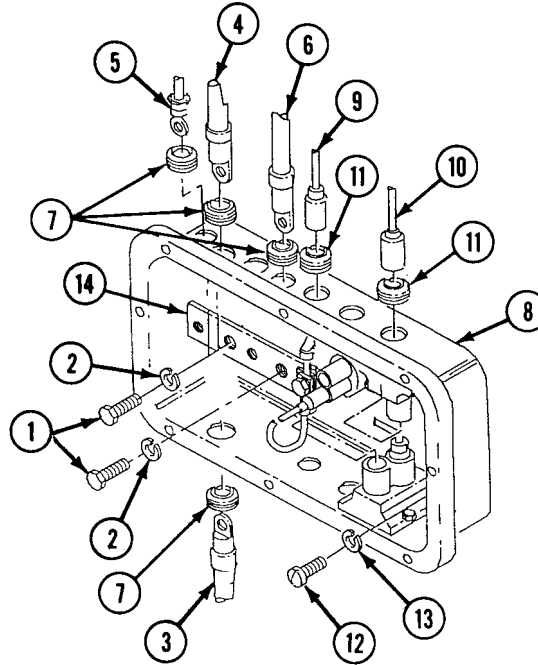

■ REPLACE DISTRIBUTION BOX (M113A3, M1059A3, M1064A3, AND M58 ONLY)
 — Continued

0269 00

INSTALLATION

1. Install distribution box (8) on hull. Secure with five screws (12) and new lockwashers (13).
2. Install circuit leads 450 (9), 450B (10), and two new grommets (11) in distribution box (8).
3. Install circuit leads 6 (3), 6A (4), 6L (5), 49 (6), and four new grommets (7) in distribution box (8). Secure leads to bus bar (14) with two screws (1) and new lockwashers (2).

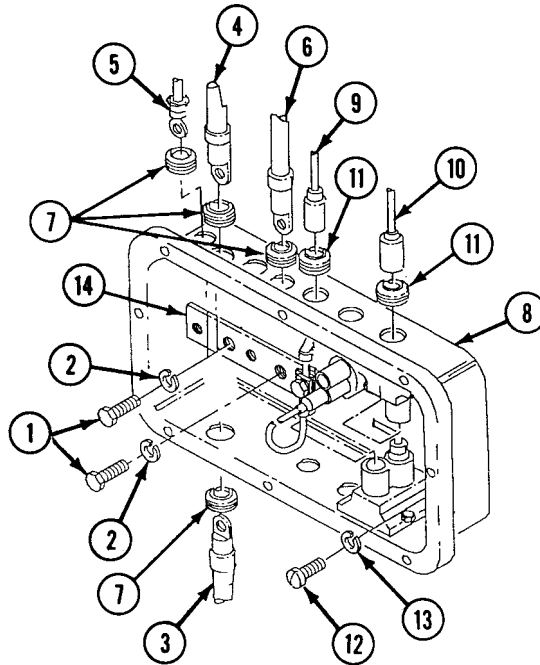

4. Install new grommet (15) on circuit lead 2 (16) and new grommet (17) on circuit lead 2A (18). Route leads into distribution box (8), and install grommets in box.

NOTE

Step 5 applies to M113A3 carriers with water/ration heater kit installed only.

5. Install circuit lead 222B (25) and grommet (26) in distribution box (8).
6. Install lead 400 (19) in distribution box (8).

REPLACE DISTRIBUTION BOX (M113A3, M1059A3, M1064A3, AND M58 ONLY)**0269 00** ■**— Continued**

7. Install circuit leads 27E, 10, 15 (20), 450A (21), and new grommet (22) in distribution box (8). Secure with screw (23) and new lockwasher (24).

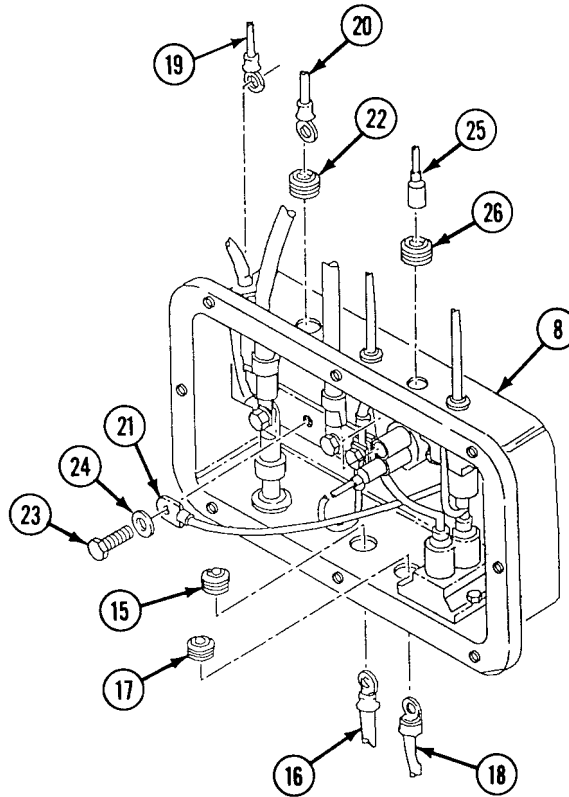
**FOLLOW-THROUGH STEPS**

1. Install master switch panel (WP 0260 00).
2. Connect battery ground strap (WP 0337 00).

END OF TASK

REPAIR DISTRIBUTION BOX (M113A3, M1059A3, M1064A3, AND M58 ONLY)

0270 00 ■

THIS WORK PACKAGE COVERS:

- Removal (page 0270 00-1).
 - Installation (page 0270 00-5).
-

INITIAL SETUP:

Maintenance Level

Unit

Personnel Required

Unit Mechanic

Tools and Special Tools

General Mechanic's Tool Kit (WP 0926 00, Item 65)

References

See your -10

Materials/Parts

Adhesive (WP 0928 00, Item 4)

Gasket

Locknut (2)

Locknut (4)

Lockwasher

Lockwasher (2)

Lockwasher (4)

Lockwasher (5)

Equipment Condition

Engine stopped (see your -10)

Carrier blocked (see your -10)

Battery ground strap disconnected (WP 0337 00)

Master switch panel assembly removed (WP 0260 00)

REMOVAL

1. Remove screw (1), lockwasher (2), circuit 27E, 10, and 15 lead (3), and circuit lead 450A (4) from bus bar (5) in distribution box (6). Remove circuit 27E, 10, and 15 lead (3) and grommet (7) from distribution box. Discard lockwasher.

NOTE

Do Step 2 and Step 3 for M113A3 carriers with water/ration heater kit installed only.

2. Disconnect circuit lead 222B (8) from water/ration heater circuit breaker (9).
3. Remove circuit lead 222B (8) and grommet (10) from distribution box (6).
4. Remove circuit leads 2 (11), 2A (12), and two grommets (13) from distribution box (6).
5. Remove screw (14), lockwasher (15), and lead 450C (16) from bus bar (5). Discard lockwasher.

NOTE

Do Step 6 and Step 7 for M113A3 carriers with water/ration heater kit installed only.

6. Remove lead 222A (17) from bus bar (5).
7. Disconnect lead 222A (17) from water/ratioheater circuit breaker (9). Remove lead 222A from distribution box (6).

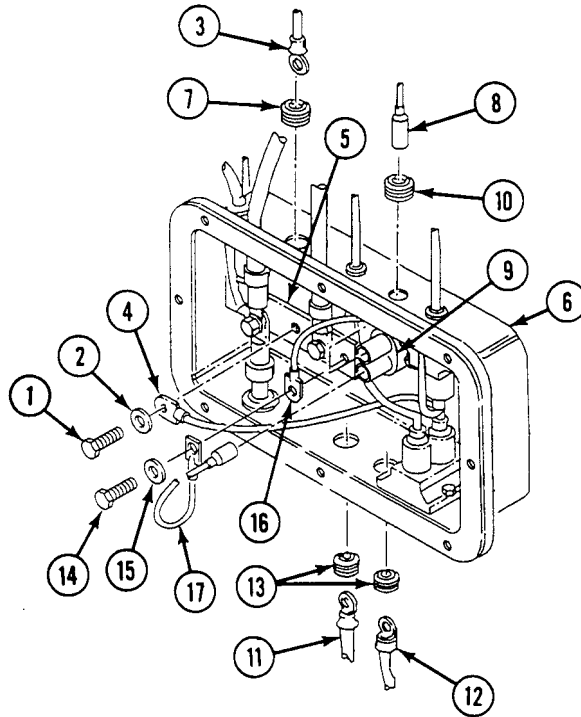

**REPAIR DISTRIBUTION BOX (M113A3, M1059A3, M1064A3, AND M58 ONLY) —
Continued**

0270 00 ■

8. Remove screw (1), lockwasher (2), and three circuit leads 6 (3), 6A (4), 6L (5), from bus bar (6). Remove bus bar and three leads with grommets (7) and (8) from distribution box (9). Discard lockwasher.

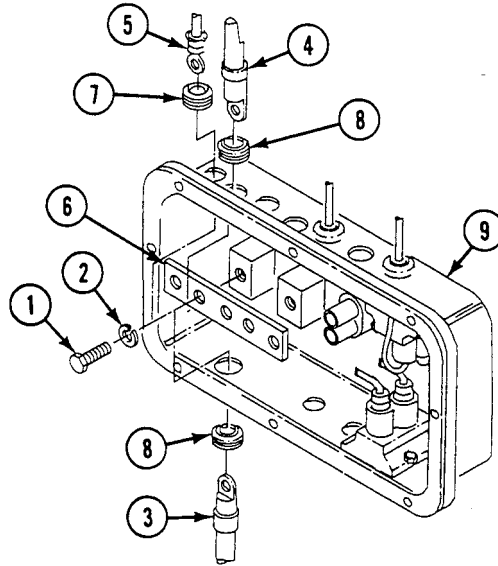

9. Disconnect circuit leads 450 (10), 450A (11), 450B (12), and 450C (13) from bilge pump circuit breakers (14). Remove leads 450A and 450C from distribution box.
10. Remove circuit leads 400 (15), 450 (10), and 450B (12) with three grommets (16) from distribution box (9).

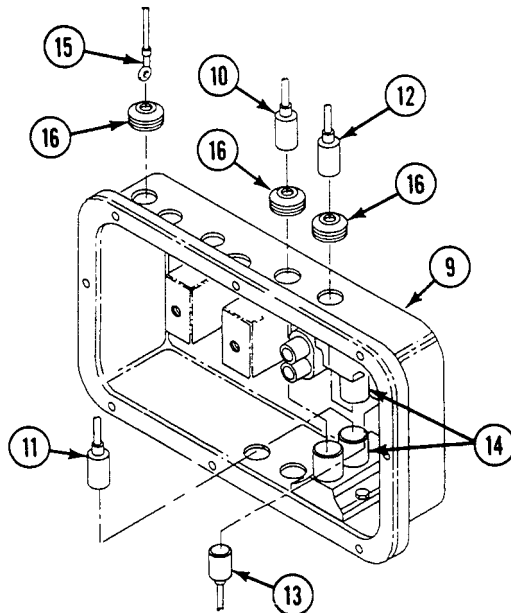

■ REPAIR DISTRIBUTION BOX (M113A3, M1059A3, M1064A3, AND M58 ONLY) —
Continued

0270 00

11. Remove five screws (17), lockwashers (18), and distribution box (9) from hull. Discard lockwashers.
12. Remove gasket (19) from distribution box (9). Discard gasket.
13. Remove four screws (20), lockwashers (21), and two blocks (22) from distribution box (9). Discard lockwashers.
14. Remove four screws (23), locknuts (24), and bilge pump circuit breakers (14) from distribution box (9). Discard locknuts.

NOTE

Do Step 15 for M113A3 carriers with water/ration heater kit installed only.

15. Remove two screws (25), locknuts (26), and water/ration heater circuit breaker (27) from distribution box (9). Discard locknuts.

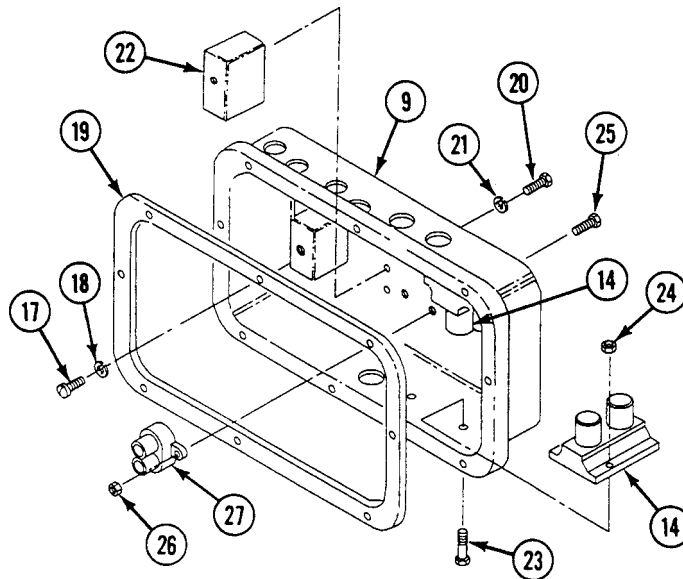

INSTALLATION

1. Install two bilge pump circuit breakers (1) in distribution box (2). Secure with four screws (3) and new locknuts (4).
2. Install two blocks (5) in distribution box (2). Secure with four screws (6) and new lockwashers (7).

NOTE

Do Step 3 for M113A3 carriers with water/ration heater kit installed only.

3. Install water/ration heater circuit breaker (8) in distribution box (2). Secure with two screws (9) and new locknuts (10).
4. Install distribution box (2) on hull. Secure with five screws (11) and new lockwashers (12).

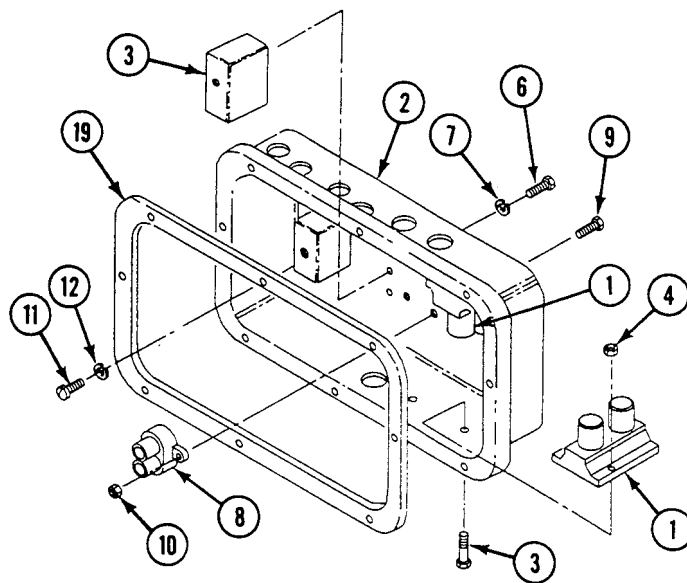

REPAIR DISTRIBUTION BOX (M113A3, M1059A3, M1064A3, AND M58 ONLY) —
Continued

0270 00

5. Install three grommets (13) on circuit leads 400 (14), 450 (15), and 450B (16). Route leads into distribution box (2) and install grommets in distribution box.
6. Connect circuit leads 450 (15), 450A (17), 450B (16), and 450C (18) to bilge pump circuit breakers (1).

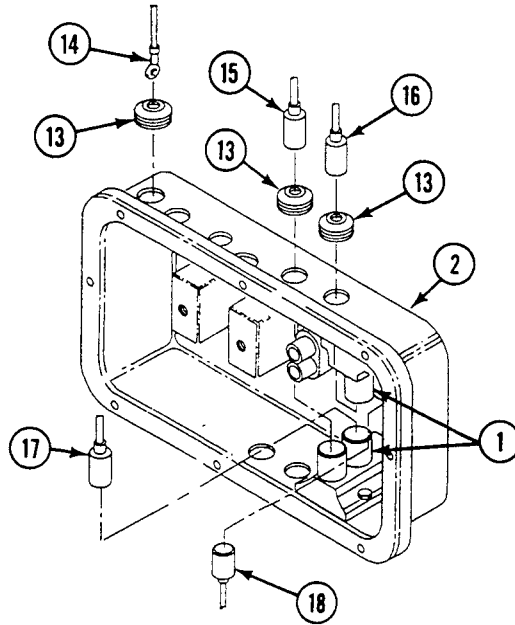

7. Install grommet (19) on circuit lead 6L (20). Route circuit lead 6L into distribution box (2) and install grommet in distribution box.
8. Install grommet (21) on circuit lead 6 (22) and grommet (23) on circuit lead 6A (24). Route leads into distribution box (2) and install grommets in distribution box.
9. Secure leads 6 (22), 6A (24), 6L (20), and bus bar (25) to distribution box (2) with screw (26) and new lockwasher (27).

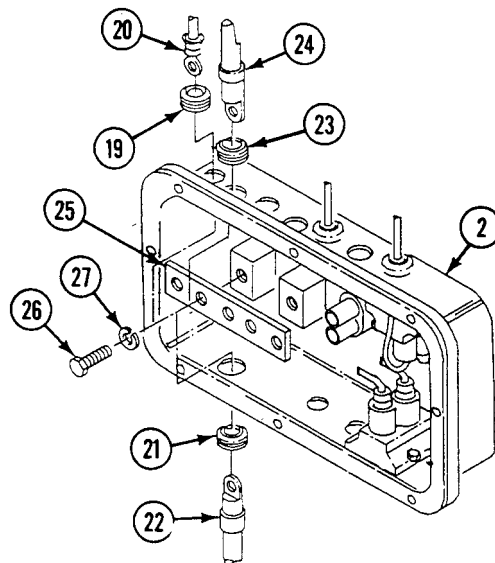

NOTE

Do Step 10 and Step 11 for M113A3 carriers with water/ration heater kit installed only.

10. Connect lead 222A (1) to water/ration heater circuit breaker (2).
11. Install lead 222A (1) on bus bar (3) in distribution box (4).
12. Secure circuit lead 450C (5) to bus bar (3) in distribution box (4) with screw (6) and new lockwasher (7).
13. Install grommet (8) on circuit lead 2 (9) and grommet (10) on lead 2A (11). Route leads into distribution box (4) and install grommets in distribution box.
14. Install grommet (12) on circuit 27E, 10, and 15 lead (13). Route lead into distribution box (4) and install grommet in distribution box.
15. Secure circuit 27E, 10, and 15 lead (13) and lead 450A (14) to bus bar (3) with screw (15) and new lockwasher (16).

NOTE

Do Step 16 and Step 17 for M113A3 carriers with water/ration heater kit installed only.

16. Install grommet (17) on circuit lead 222B (18). Route lead into distribution box (4) and install grommet in distribution box.
17. Connect circuit lead 222B (18) to water/ration circuit breaker (2) in distribution box (4).

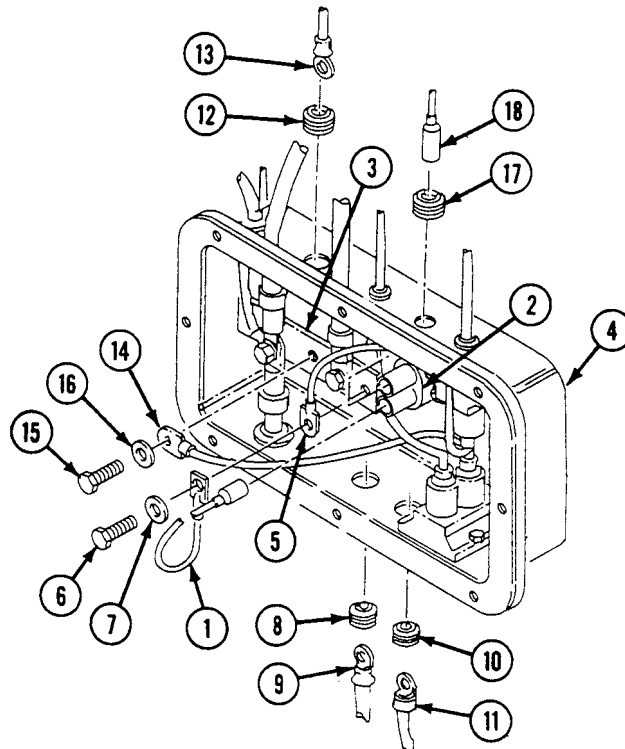

REPAIR DISTRIBUTION BOX (M113A3, M1059A3, M1064A3, AND M58 ONLY) —
Continued

0270 00 ■

18. Apply thin coat of adhesive sealant to one side of gasket (19) and to mounting surface of distribution box (4). Install gasket on distribution box.

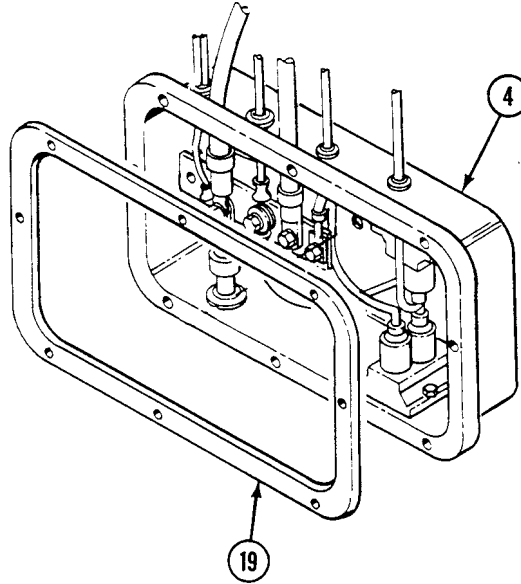
**FOLLOW-THROUGH STEPS**

1. Install master switch panel assembly (WP 0260 00).
2. Connect battery ground strap (WP 0337 00).

END OF TASK

REPLACE DISTRIBUTION BOX ASSEMBLY (M577A3 AND M1068A3 ONLY)

0271 00

THIS WORK PACKAGE COVERS:

Removal (page 0271 00-1).
 Installation (page 0271 00-3).

INITIAL SETUP:

Maintenance Level

Unit

Personnel Required

Unit Mechanic

Tools and Special Tools

General Mechanic's Tool Kit (WP 0926 00, Item 65)

References

See your -10

Materials/Parts

Adhesive (WP 0928 00, Item 4)
 Gasket
 Grommet (9)
 Lockwasher (5)
 Lockwasher (5)

Equipment Condition

Engine stopped (see your -10)
 Carrier blocked (see your -10)
 Battery ground lead disconnected (WP 0338 00)
 Master switch panel assembly removed (WP 0261 00)

REMOVAL

1. Remove screw (1), lockwasher (2), and circuit 415 lead (3) from bus bar (4). Remove circuit 415 lead and grommet (5) from distribution box (6). Discard grommet and lockwasher.
2. Remove screw (7), lockwasher (8), circuit 6 lead (9), and circuit 49 lead (10) from bus bar (4). Remove circuit 6 lead, circuit 49 lead, and two grommets (11), (12) from distribution box (6). Discard grommets and lockwasher.
3. Remove screw (13), lockwasher (14), circuit 10, 14, 15, 27E lead (15), and circuit 450A lead (16) from bus bar (4). Remove circuit 10, 14, 15, 27E lead and grommet (17) from distribution box (6). Discard grommet and lockwasher.
4. Remove screw (18), lockwasher (19), and wiring harness (20) from bus bar (4). Discard lockwasher.

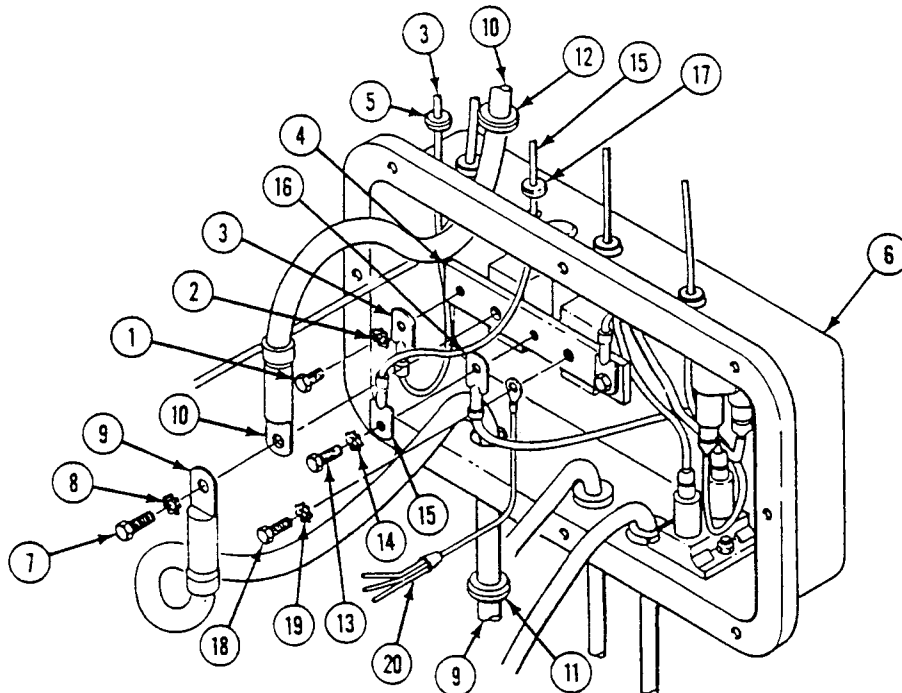

5. Disconnect circuit 450 lead (1) from circuit breaker (2). Remove circuit 450 lead and grommet (3) from distribution box (4). Discard grommet.
6. Disconnect circuit 450B lead (5) from circuit breaker (6). Remove circuit 450B lead and grommet (7) from distribution box (4). Discard grommet.

NOTE

If bilge pump circuit breakers must be removed, see (WP 0275 00) for removal. If bilge pump circuit breakers are not to be removed, go to Step 10.

7. Remove screw (8), lockwasher (9), and circuit 450C lead (10) from bus bar (11). Discard lockwasher.
8. Disconnect circuit 450C lead (10) from circuit breaker (12). Remove circuit 450C lead from distribution box (4).
9. Disconnect circuit 450A lead (13) from circuit breaker (14). Remove circuit 450A lead from distribution box (4).
10. Remove circuit 400 lead (15) and grommet (16) from distribution box (4). Discard grommet.
11. Remove circuit 2 lead (17) and grommet (18) from distribution box (4). Discard grommet.
12. Remove circuit 2A lead (19) and grommet (20) from distribution box (4). Discard grommet.

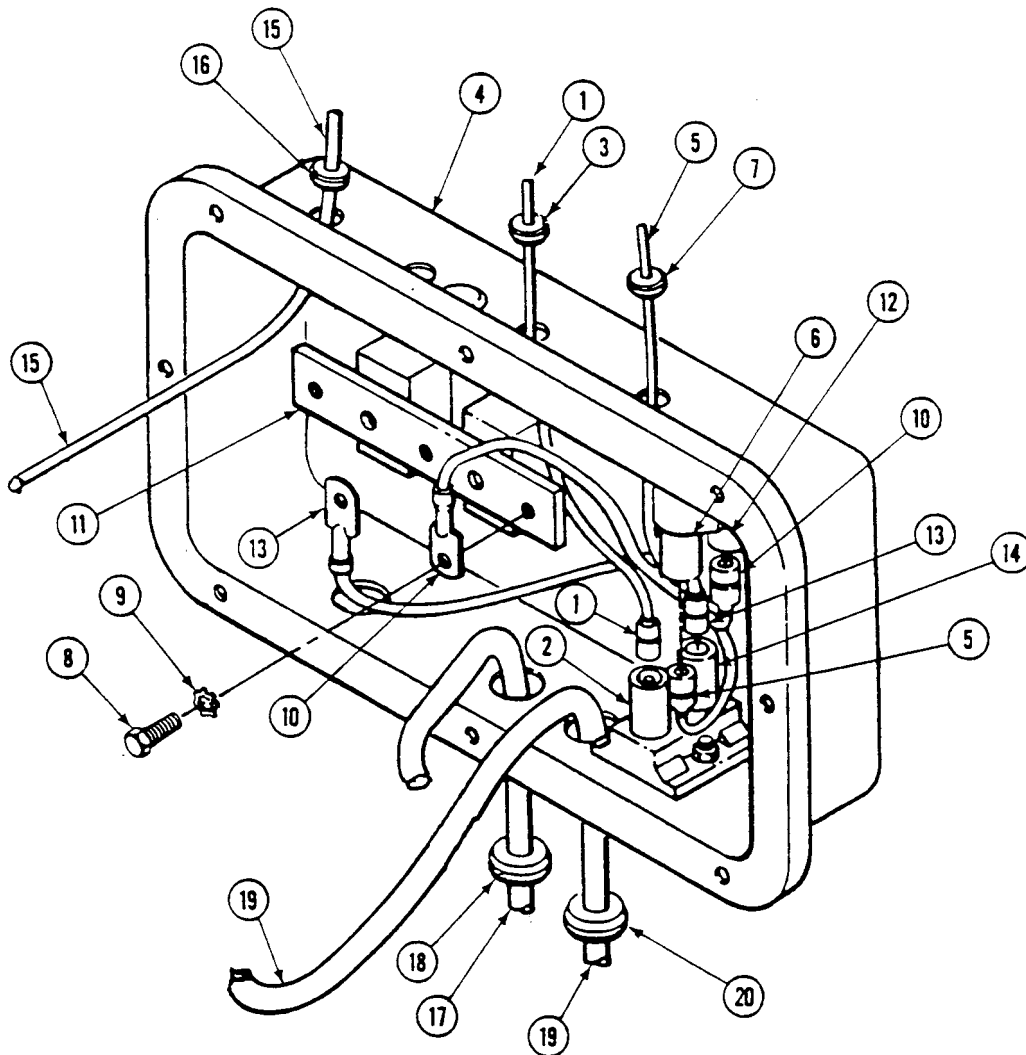

13. Remove five screws (1), lockwashers (2), and distribution box (3) from hull. Discard lockwashers.
14. Remove gasket (4) from distribution box (3). Discard gasket.

INSTALLATION

1. Install distribution box (3) on hull. Secure with five new lockwashers (2) and screws (1). Retain new gasket (4) for later installation.

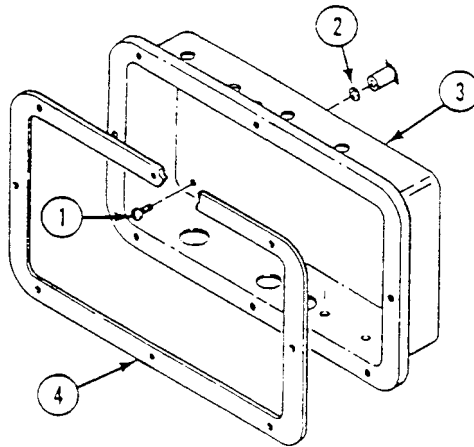

2. Install new grommet (5) and circuit 2A lead (6) in distribution box (3).
3. Install new grommet (7) and circuit 2 lead (8) in distribution box (3).
4. Install new grommet (9) and circuit 400 lead (10) in distribution box (3).

NOTE

If bilge pump circuit breakers were removed, see (WP 0275 00) for installation. If bilge pump circuit breakers were not removed, go to Step 8.

5. Connect circuit 450A lead (11) to circuit breaker (12).
6. Connect circuit 450C lead (13) to circuit breaker (14).
7. Install circuit 450C lead (13) on bus bar (15). Secure with new lockwasher (16) and screw (17).
8. Install new grommet (18) and circuit 450B lead (19) in distribution box (3). Connect circuit 450B lead to circuit breaker (20).
9. Install new grommet (21) and circuit 450 lead (22) in distribution box (3). Connect circuit 450 lead to circuit breaker (23).

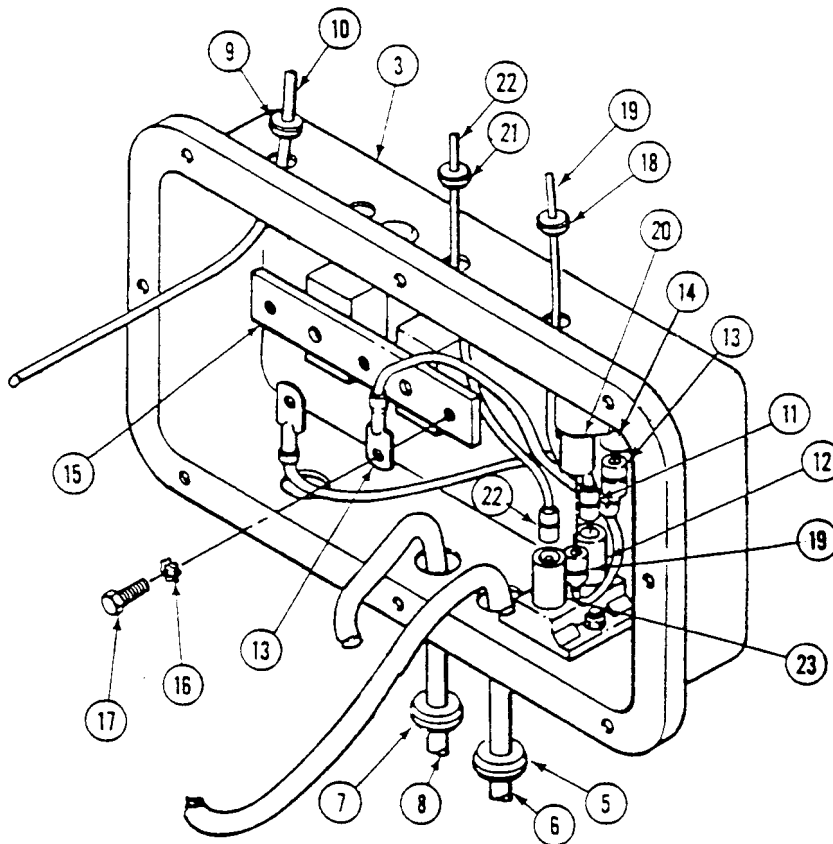

10. Install wiring harness (1) on bus bar (2). Secure with new lockwasher (3) and screw (4).
11. Install new grommet (5) and circuit 10, 14, 15, 27E lead (6) in distribution box (7). Install circuit 10, 14, 15, 27E lead (6) and circuit 450A lead (8) on bus bar (2). Secure with new lockwasher (9) and screw (10).
12. Install two new grommets (11) and (12), circuit 49 lead (13), and circuit 6 lead (14) in distribution box (7). Install circuit 49 lead (13) and circuit 6 lead (14) on bus bar (2). Secure with new lockwasher (15) and screw (16).
13. Install new grommet (17) and circuit 415 lead (18) in distribution box (7). Install circuit 415 lead (18) on bus bar (2). Secure with new lockwasher (19) and screw (20).

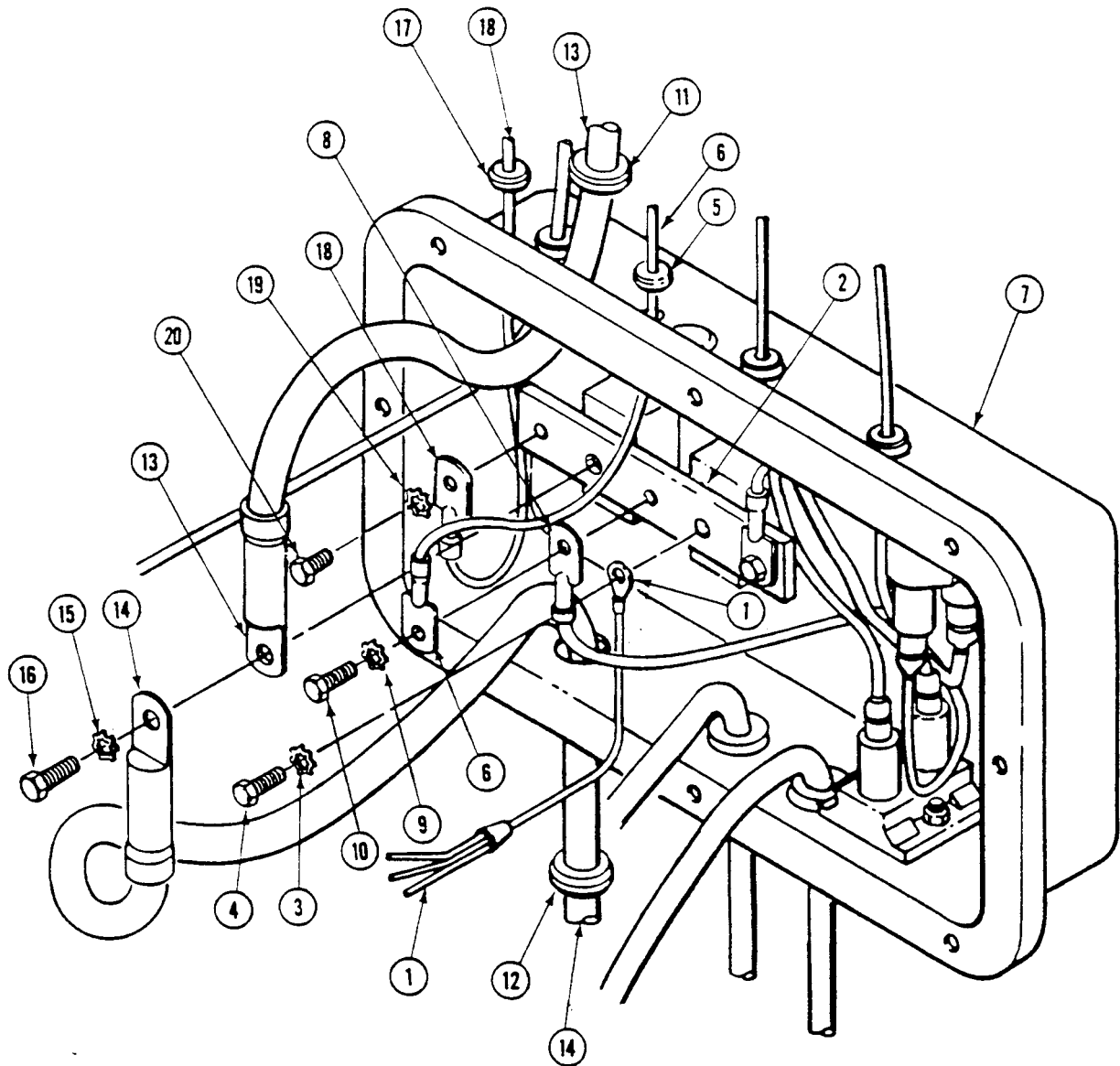

14. Apply one coat of adhesive to cleaned mounting surface of distribution box (1) and one side of new gasket (2).
15. Install new gasket (2) on coated mounting surface of distribution box (1).

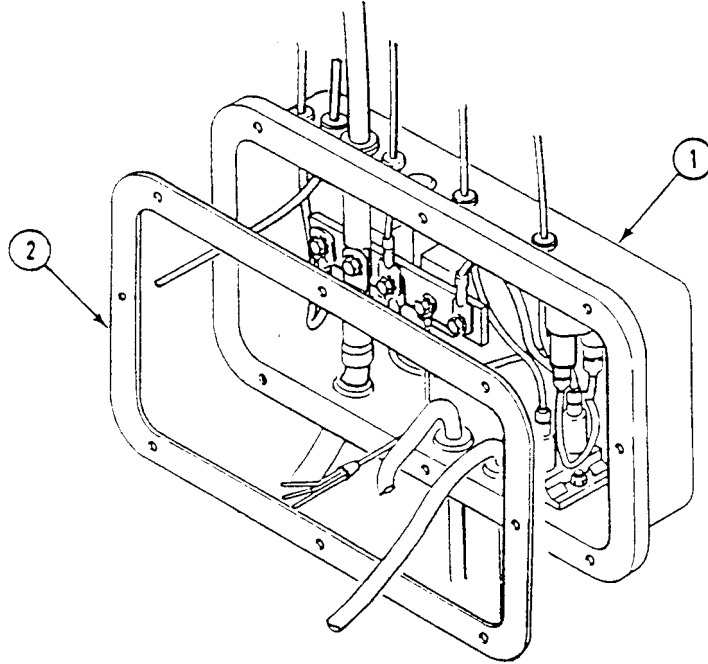
**FOLLOW-THROUGH STEPS**

1. Install master switch panel (WP 0261 00).
2. Connect battery ground lead (WP 0338 00).
3. Start engine (see your -10).
4. Check that distribution box is operable (see your -10).
5. Stop engine (see your -10).

END OF TASK

REPLACE BILGE PUMP CIRCUIT BREAKERS

0275 00

THIS WORK PACKAGE COVERS:

- Removal (page 0275 00-1).
- Installation (page 0275 00-2).

INITIAL SETUP:

Maintenance Level

Unit

References

See your -10

Tools and Special Tools

General Mechanic's Tool Kit (WP 0926 00, Item 65)

Equipment Condition

Engine stopped (see your -10)

Materials/Parts

Locknut (8)

Carrier blocked (see your -10)

Locknut (4)

Battery ground strap disconnected (WP 0337 00) or (WP 0338 00)

Personnel Required

Unit Mechanic

Instrument warning light panel removed (WP 0260 00)

REMOVAL

1. Remove eight screws (1), washers (2), and locknuts (3) from master switch panel (4) and distribution box (5). Remove master switch panel from distribution box. Discard locknuts.
2. Disconnect circuit 450 lead (6) and circuit 450A lead (7) from front bilge pump circuit breaker (8).
3. Disconnect circuit 450B lead (9) and circuit 450C lead (10) from rear bilge pump circuit breaker (11).
4. Remove four locknuts (12), screws (13), and two circuit breakers (8) and (11) from distribution box (5). Discard locknuts

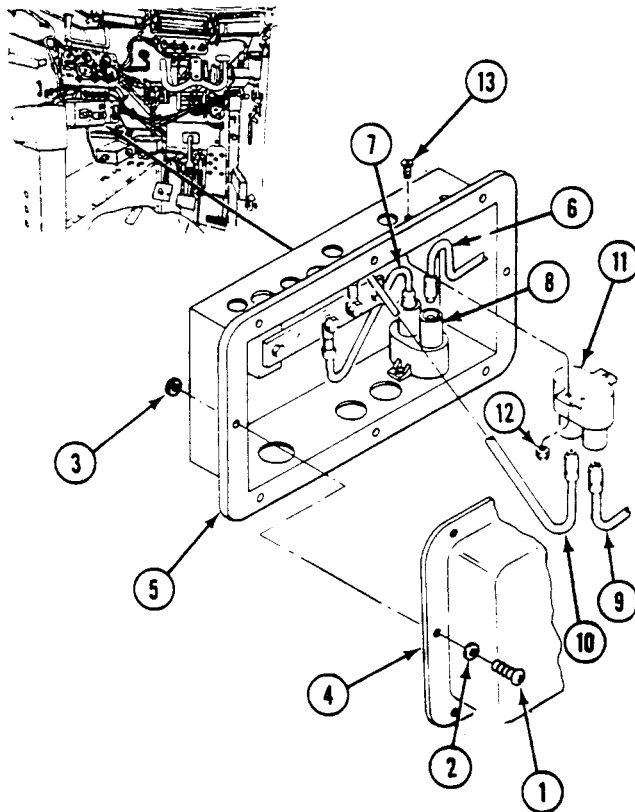

INSTALLATION

1. Install two circuit breakers (1) and (2) in distribution box (3). Secure with four screws (4) and new locknuts (5).
2. Connect circuit 450C lead (6) and circuit 450B lead (7) to rear bilge pump circuit breaker (2).
3. Connect circuit 450A lead (8) and circuit 450 lead (9) to front bilge pump circuit breaker (1).
4. Place master switch panel (10) on distribution box (3). Secure with eight screws (11), washers (12), and new locknuts (13).

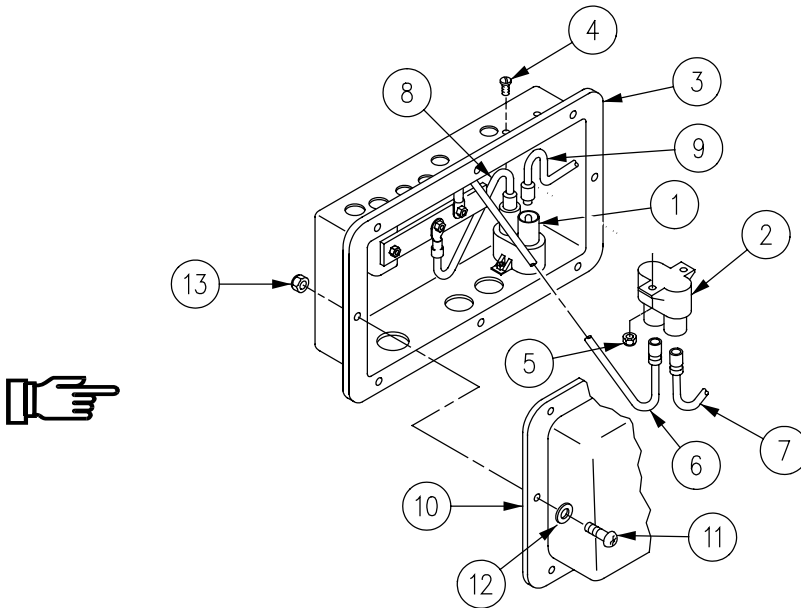
**FOLLOW-THROUGH STEPS**

1. Install instrument warning light panel (WP 0260 00).
2. Connect battery ground strap (WP 0337 00) or (WP 0338 00).
3. Turn MASTER SWITCH to ON (see your -10).
4. Turn bilge pump switches to ON to check that bilge pump circuit breaker works properly (see your -10). Bilge pump lights should come on (see your -10).
5. Turn all switches to OFF (see your -10).

END OF TASK

REPLACE REAR UTILITY RECEPTACLE CIRCUIT BREAKERS (M577A3 AND M1068A3 ONLY)

0276 00

THIS WORK PACKAGE COVERS:

- Removal (page 0276 00-1).
- Inspection and Repair (page 0276 00-2).
- Installation (page 0276 00-3).

INITIAL SETUP:

Maintenance Level

Unit

Personnel Required

Unit Mechanic

Tools and Special Tools

General Mechanic's Tool Kit (WP 0926 00, Item 65)

References

See your -10

Materials/Parts

Gasket

Locknut (8)

Equipment Condition

Engine stopped (see your -10)

Carrier blocked (see your -10)

Battery ground lead disconnected (WP 0338 00)

REMOVAL

NOTE

If you want to remove only the left circuit breaker, skip Step 3. If you want to remove only the right circuit breaker, skip Step 2.

1. Remove eight locknuts (1), washers (2), screws (3), and master switch panel (4) from distribution box (5). Discard locknuts.

REPLACE REAR UTILITY RECEPTACLE CIRCUIT BREAKERS (M577A3 AND M1068A3 ONLY) — Continued

0276 00

2. Disconnect circuit 10 lead (6) and circuit 37A lead (7) from left circuit breaker (8).
3. Disconnect circuit 38B lead (9) and circuit 10 lead (10) from right circuit breaker (11).
4. Remove four nuts (12), screws (13), and circuit breakers (8) and (11) from distribution box (5).

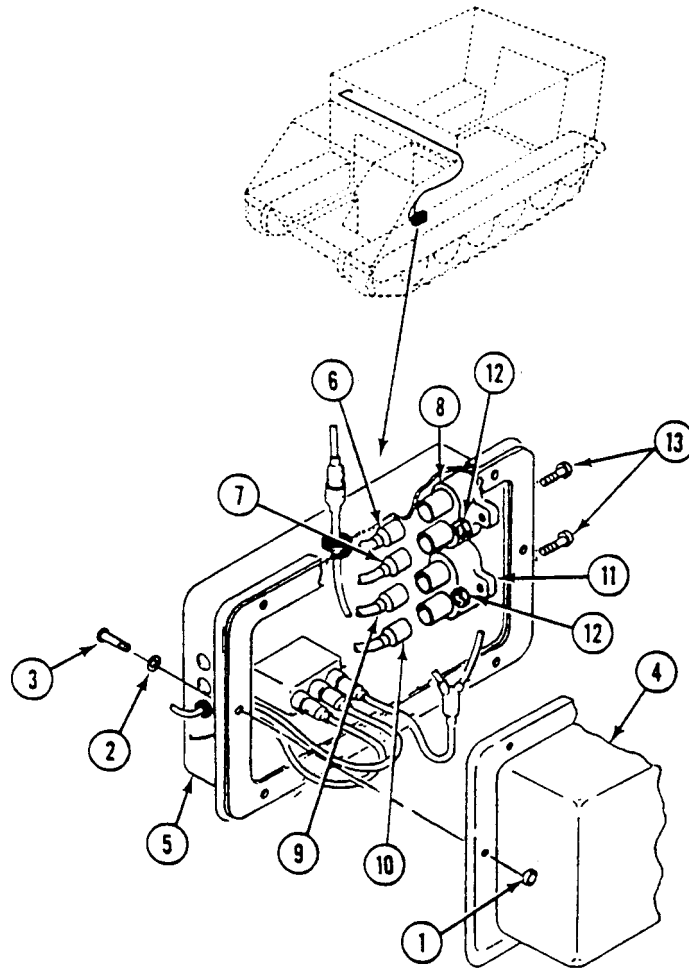
**INSPECTION-ACCEPTANCE AND REJECTION CRITERIA**

1. Inspect gasket on flange of distribution box. Replace if damaged.

REPLACE REAR UTILITY RECEPTACLE CIRCUIT BREAKERS (M577A3 AND M1068A3 ONLY) — Continued

0276 00

INSTALLATION

1. Install circuit breaker (1) in distribution box (2). Secure with two screws (3) and nuts (4).
2. Install circuit breaker (5) in distribution box (2). Secure with two screws (3) and nuts (4).
3. Connect circuit 10 lead (6) and circuit 37A lead (7) to circuit breaker (1).
4. Connect circuit 37B lead (8) and circuit 10 lead (9) to circuit breaker (5).
5. Install master switch panel (10) on distribution box (2). Secure with eight screws (11), washers (12), and new locknuts (13).

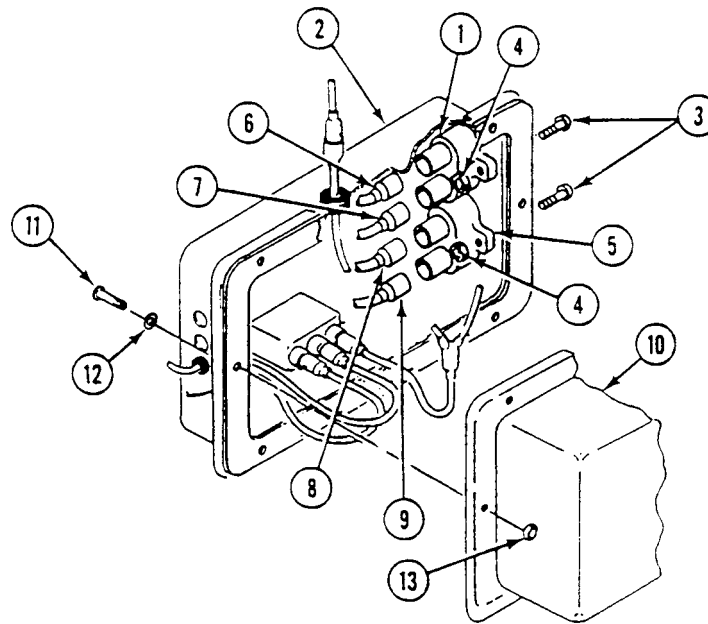
**FOLLOW-THROUGH STEPS**

1. Connect battery ground lead (WP 0338 00).
2. Turn MASTER SWITCH ON (see your -10).
3. Check for power at utility outlet receptacles (see your -10).
4. Turn MASTER SWITCH OFF (see your -10).

END OF TASK

REPLACE FUEL SELECTOR SWITCH (M577A3 AND M1068A3 ONLY)

0277 00

THIS WORK PACKAGE COVERS:

Removal (page 0277 00-1).
 Installation (page 0277 00-3).

INITIAL SETUP:

Maintenance Level

Unit

Personnel Required

Unit Mechanic

Tools and Special Tools

General Mechanic's Tool Kit (WP 0926 00, Item 65)

References

See your -10

Materials/Parts

Gasket

Locknut (8)

Equipment Condition

Engine stopped (see your -10)

Carrier blocked (see your -10)

Battery ground lead disconnected (WP 0338 00)

REMOVAL

1. Remove eight locknuts (1), washers (2), screws (3), and master switch panel (4) from distribution box (5). Discard locknuts.

REPLACE FUEL SELECTOR SWITCH (M577A3 AND M1068A3 ONLY) — Continued**0277 00**

2. Disconnect circuit 28 lead (6), circuit 29 lead (7), and circuit 30 lead (8) from fuel selector switch (9).
3. Remove two screws (10) and fuel selector switch (9) from master switch panel (4).
4. Inspect gasket (11). Replace if needed.

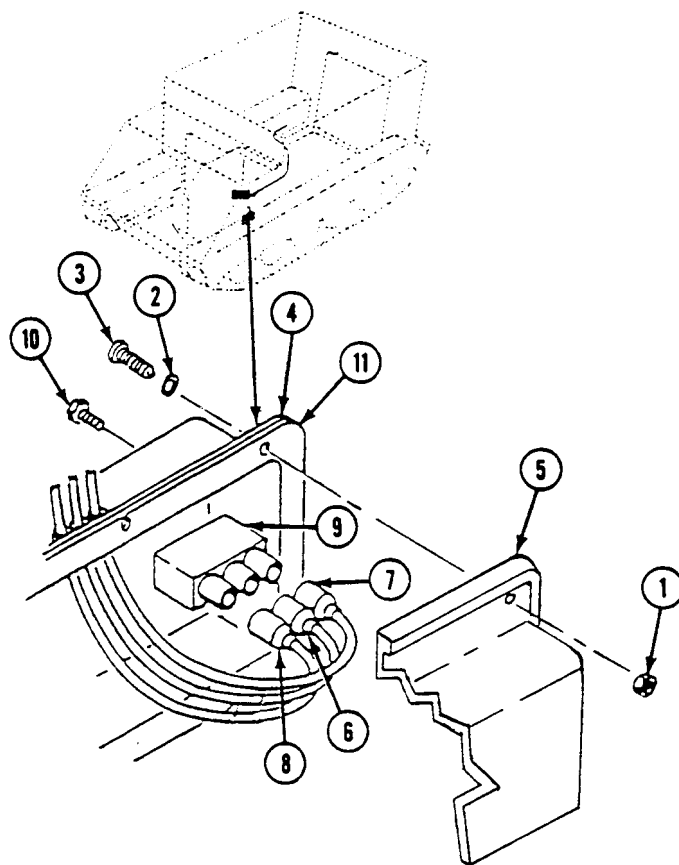

INSTALLATION

1. Install fuel selector switch (9) on master switch panel (4). Secure with two screws (10).
2. Connect circuit 30 lead (8), circuit 29 lead (7), and circuit 28 lead (6) to fuel selector switch (9).
3. Install master switch panel (4) on distribution box (5). Secure with eight screws (3), washers (2), and new locknuts (1).

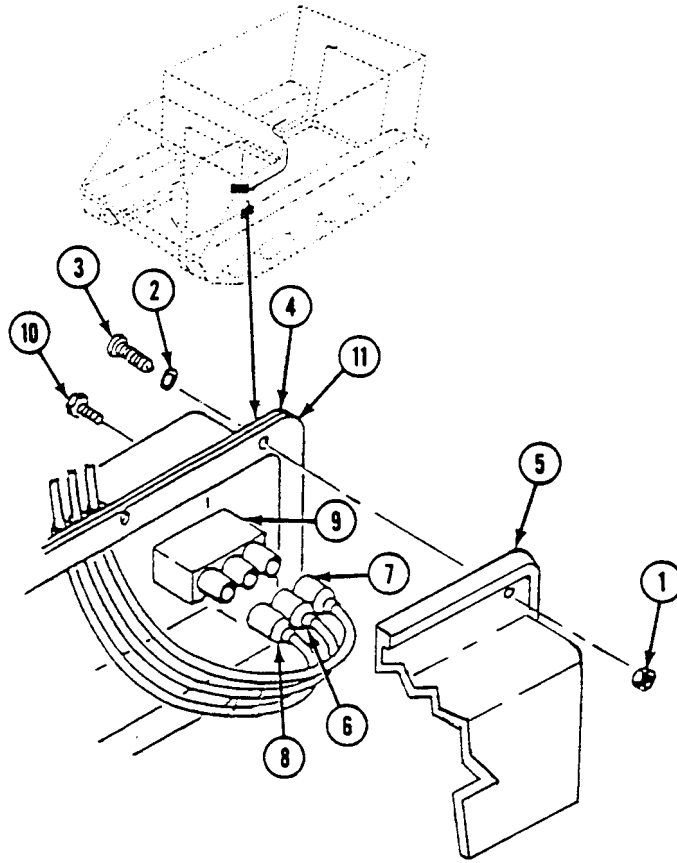
**FOLLOW-THROUGH STEPS**

1. Connect battery ground lead (WP 0338 00) .
2. Turn MASTER SWITCH ON (see your -10).
3. Move FUEL SELECTOR SWITCH to opposite position (see your -10). Check that fuel gage needle moves to correspond to left and right fuel tank levels (see your -10).
4. Turn MASTER SWITCH OFF (see your -10).

END OF TASK

REPLACE BLOWER SWITCH (M577A3 AND M1068A3 ONLY)

0278 00

THIS WORK PACKAGE COVERS:

Removal (page 0278 00-1).
 Installation (page 0278 00-3).

INITIAL SETUP:

Maintenance Level

Unit

Personnel Required

Unit Mechanic

Tools and Special Tools

General Mechanic's Tool Kit (WP 0926 00, Item 65)

References

See your -10

Materials/Parts

Gasket
 Locknut (8)

Equipment Condition

Engine stopped (see your -10)
 Carrier blocked (see your -10)
 Battery ground lead disconnected (WP 0338 00)

REMOVAL

1. Remove eight locknuts (1), washers (2), screws (3), and master switch panel (4) from distribution box (5). Discard locknuts.

2. Disconnect two circuit 59 leads (6) from blower switch (7).
3. Remove two screws (8) and blower switch (7) from master switch panel (4).
4. Inspect gasket (9). Replace if damaged.

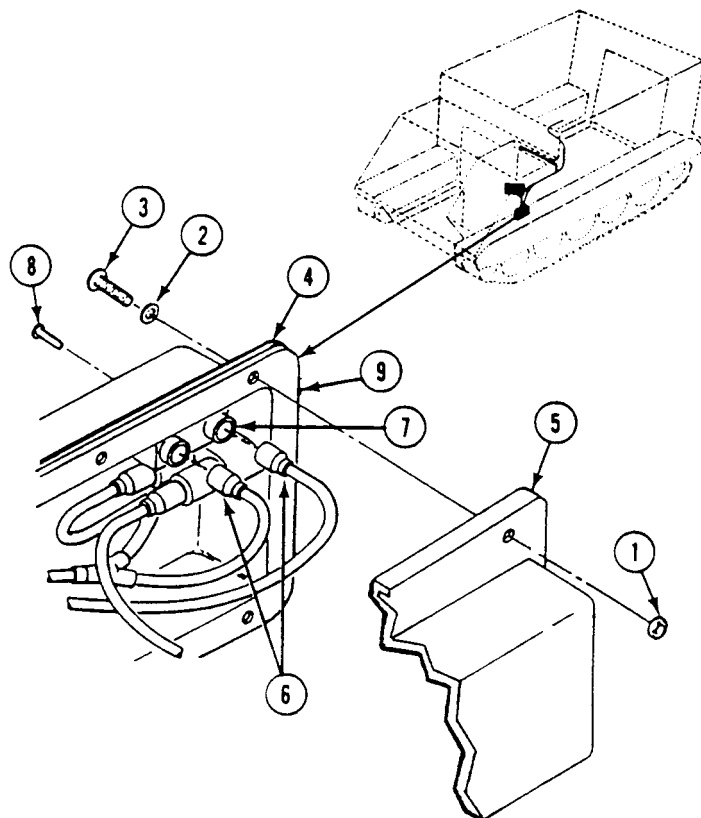

INSTALLATION

1. Install blower switch (7) on master switch panel (4). Secure with two screws (8).
2. Connect two circuit 59 leads (6) to blower switch (7).
3. Install master switch panel (4) on distribution box (5). Secure with eight screws (3), washers (2), and new locknuts (1).

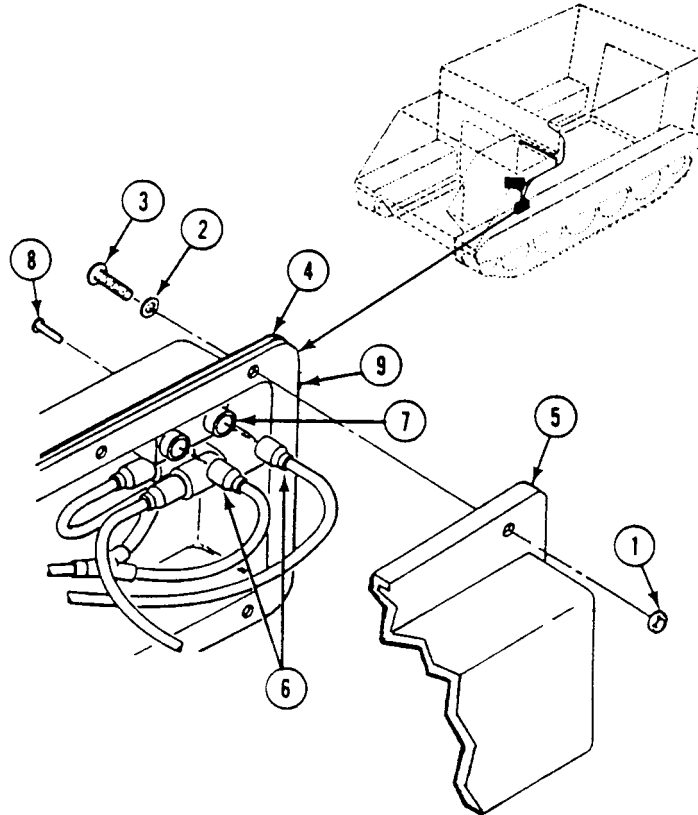
**FOLLOW-THROUGH STEPS**

1. Connect battery ground lead (WP 0338 00).
2. Turn MASTER SWITCH to ON (see your -10).
3. Turn blower switch ON. Blower should run (see your -10).
4. Turn all switches to OFF (see your -10).

END OF TASK

REPLACE INSTRUMENT PANEL ASSEMBLY (ALL EXCEPT M58)

0279 00 ■

THIS WORK PACKAGE COVERS:

Removal (page 0279 00-2).
 Installation (page 0279 00-5).

INITIAL SETUP:

Maintenance Level

Unit

Tools and Special Tools

General Mechanic's Tool Kit (WP 0926 00, Item 65)
 Electrical Connector Pliers (WP 0926 00, Item 31)

Personnel Required

Unit Mechanic

References

TM 9-2350-277-10

Equipment Condition

Engine stopped (see your -10)
 Carrier blocked (see your -10)
 Battery ground strap disconnected (WP 0337 00),
 (WP 0338 00), or (WP 0339 00)
 Tachometer and speedometer cables disconnected from
 instrument panel gauges (WP 0858 00)
 Instrument panel, mounts, and two ground leads
 removed from struts (WP 0295 00)

REMOVAL

1. Disconnect lead 451B (1) from rear bilge pump ON indicator (2).
2. Disconnect lead 452B (3) from front bilge pump ON indicator (4).
3. Disconnect lead 450B (5), lead 450 (6), lead 451A (7), and lead 452A (8) from bilge pump switch (9).
4. Disconnect front main harness connector (10) from main light switch (11).
5. Disconnect lead 33 (12) and special purpose harness lead 27B (13) from engine coolant temperature gauge (14).
6. Disconnect two circuit 40 leads (15) and (16) from lamp assembly (17).
7. Disconnect special purpose harness lead 459 (18) from master switch indicator (19).

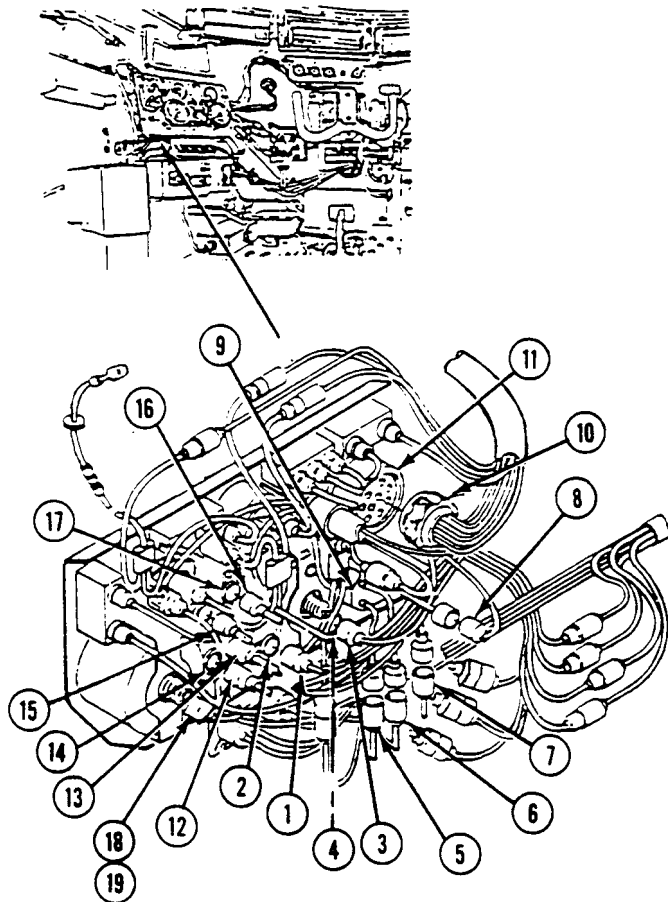

REPLACE INSTRUMENT PANEL ASSEMBLY (ALL EXCEPT M58) — Continued

0279 00

8. Disconnect lead 14B (1) from start switch lead 14 (2).
9. Disconnect lead 74 (3) and lead 14 (2) from start switch (4).
10. Disconnect front main harness 516A lead (5) and special purpose harness lead 516 (6) from IR POWER or DTV (M58 only) switch (7).
11. Disconnect lead 514/515 (8), lead 520 (9), and lead 19 (10) from infrared blackout switch (11).
12. Disconnect battery/generator harness lead 27E (12) from battery/generator gauge (13).
13. Disconnect battery/generator harness lead 10 or lead 10A (M58 only) (14) and special purpose harness lead 27 (15) from circuit breaker (16).
14. Disconnect lead 31 (17) and lead 30 (18) from fuel tank switch (19) (except on M577A3 and M1068A3 carriers).
15. Disconnect lead 406 (20) and special purpose harness lead 27C (21) from air box heater switch (22) or glow plug switch (39).

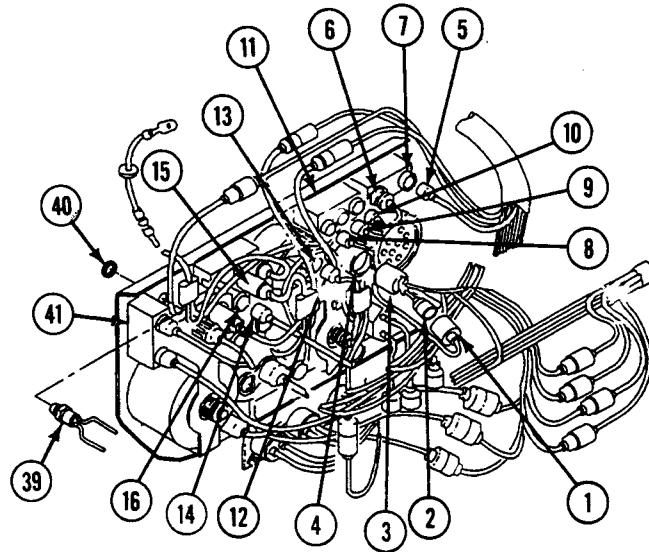

NOTE

Skip Step 16 if your carrier has air box heater system.

16. Remove knurled nut (40) and glow plug indicator (41).
17. Disconnect lead 25A (23), lead 27F (24), lead 27P (25), and lead 38 (26) from special purpose cable (27).
18. Disconnect lead 323/27R (28) from transmission oil clogged indicator (29).
19. Disconnect lead 367/27L (30) from transmission low oil pressure indicator (31).
20. Disconnect lead 370/27M (32) from parking brake indicator (33).
21. Disconnect lead 519/519A (34) from headlight HI beam indicator (35).
22. Disconnect special purpose harness lead 27A (36) and lead 28 (37) from fuel gauge (38).

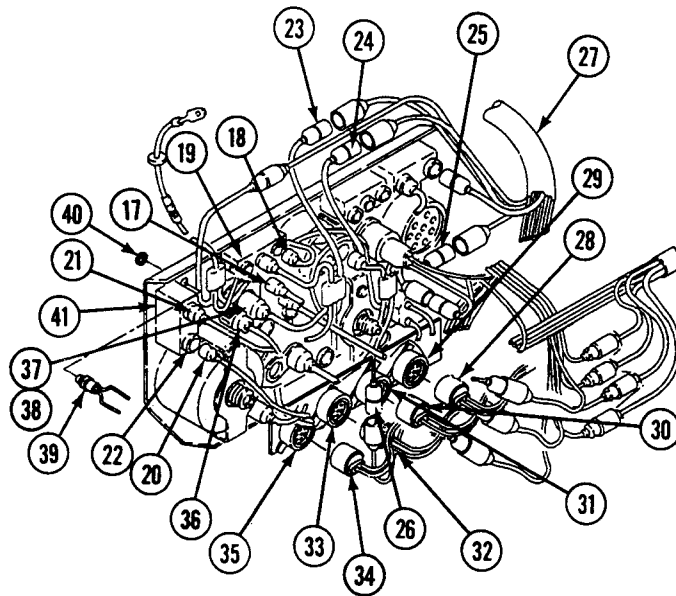

INSTALLATION

1. Connect lead 519/519A (1) to headlight HI beam indicator (2).
2. Connect lead 370/27M (3) to parking brake indicator (4).
3. Connect lead 367/27L (5) to transmission low oil pressure indicator (6).
4. Connect lead 323/27R (7) to transmission oil clogged indicator (8).
5. Connect lead 38 (9), lead 27P (10), lead 25A (11), and lead 27F (12) to special purpose cable (13).
6. Connect lead 406 (14) and special purpose harness lead 27C (15) to air box heater switch (16) or glow plug switch (36).

NOTE

Skip Step 7 if your carrier has air box system.

7. Install glow plug indicator (37) and secure with knurled nut (38).

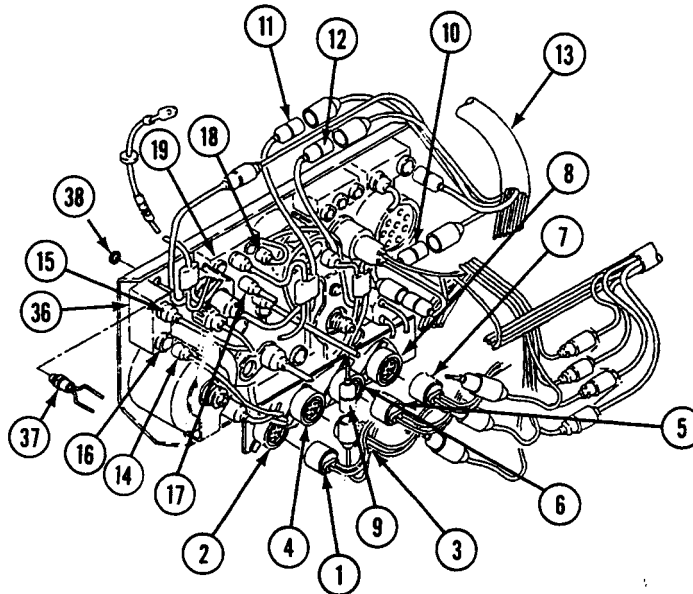

REPLACE INSTRUMENT PANEL ASSEMBLY (ALL EXCEPT M58) — Continued

0279 00

8. Connect lead 31 (17) and lead 30 (18) to fuel tank switch (19) (except on M577A3 and M1068A3 carriers).
9. Connect battery/generator harness lead 10 or lead 10A (M58 only) (20) and special purpose harness lead 27 (21) to circuit breaker (22).
10. Connect battery/generator harness lead 27E (23) to battery/generator gauge (24).
11. Connect lead 514 (25), lead 520 (26), and lead 19 (27) to infrared blackout switch (28).
12. Connect front main harness 516A (29) and special purpose harness lead 516 (30) to IR POWER or DTV (M58 only) switch (31).
13. Connect lead 74 (32) and lead 14 (33) to start switch (34).
14. Connect lead 14B (35) to start switch lead 14 (33).

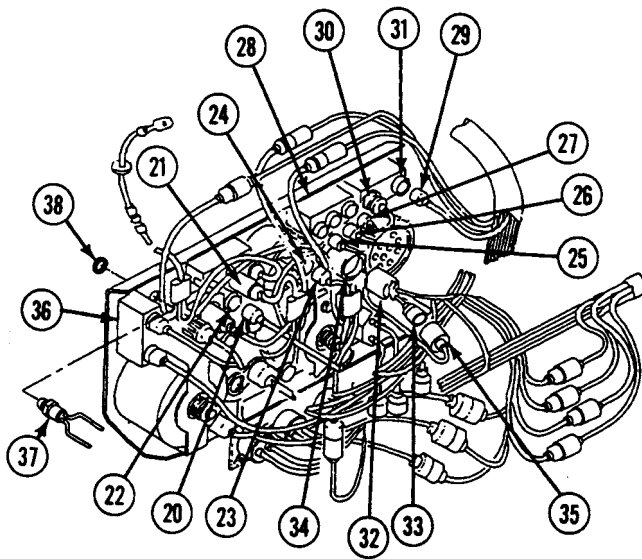

REPLACE INSTRUMENT PANEL ASSEMBLY (ALL EXCEPT M58) — Continued**0279 00**

15. Connect two circuit 40 leads (1) and (2) to lamp assembly (3).
16. Connect lead 33 (4) and special purpose harness lead 27B (5) to engine coolant temperature gauge (6).
17. Connect front main harness connector (7) to main light switch (8).
18. Connect lead 450B (9), lead 450 (10), lead 451A (11), and lead 452A (12) to bilge pump switch (13).
19. Connect lead 452B (14) to bilge front pump ON indicator (15).
20. Connect lead 451B (16) to rear bilge pump ON indicator (17).
21. Connect special purpose harness lead 27A (18) and lead 28 (19) to fuel gauge (20).
22. Connect special purpose harness lead 459 (21) to master switch indicator (22).

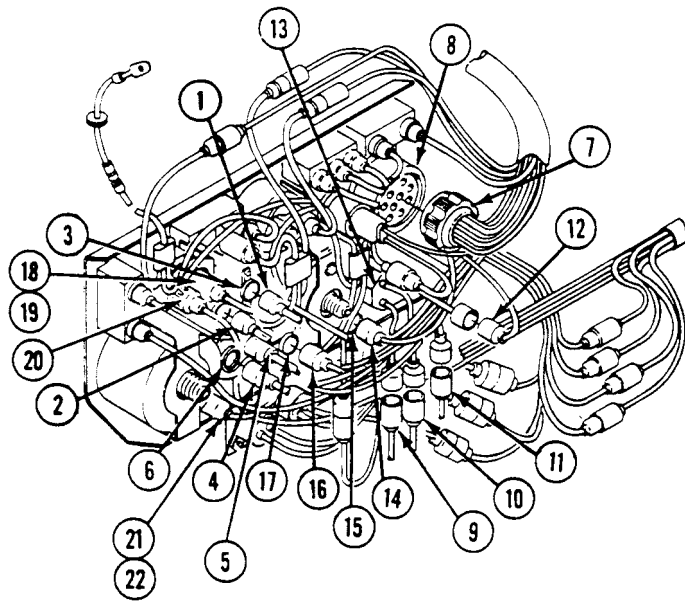
**FOLLOW-THROUGH STEPS**

1. Install two ground leads, mounts, and instrument panel on struts (WP 0295 00).
2. Install tachometer and speedometer cables on instrument panel gauges (WP 0858 00).
3. Connect battery ground strap (WP 0337 00), (WP 0338 00), or (WP 0339 00).

END OF TASK

REPLACE INSTRUMENT PANEL ASSEMBLY (M58 ONLY)

0279 01

THIS WORK PACKAGE COVERS:

Removal (page 0279 01-1).
 Installation (page 0279 01-5).

INITIAL SETUP:

Maintenance Level

Unit

Tools and Special Tools

General Mechanic's Tool Kit (WP 0926 00, Item 65)
 Electrical Connector Pliers (WP 0926 00, Item 31)

Personnel Required

Unit Mechanic

Equipment Condition

Engine stopped (see your -10)
 Carrier blocked (see your -10)
 Battery ground strap disconnected (WP 0337 00)
 Tachometer and speedometer cables disconnected from instrument panel gauges (WP 0858 00)
 Instrument panel, mounts, and two ground leads removed from struts (WP 0295 01)

References

TM 9-2350-277-10

REMOVAL

1. Disconnect lead 451B (15) from rear bilge pump ON indicator (16).
2. Disconnect lead 452B (14) from front bilge pump ON indicator (6).
3. Disconnect lead 450B (13), lead 450 (12), lead 451A (11), and lead 452A (10) from bilge pump switch (7).
4. Disconnect front main harness connector (9) from main light switch (8).

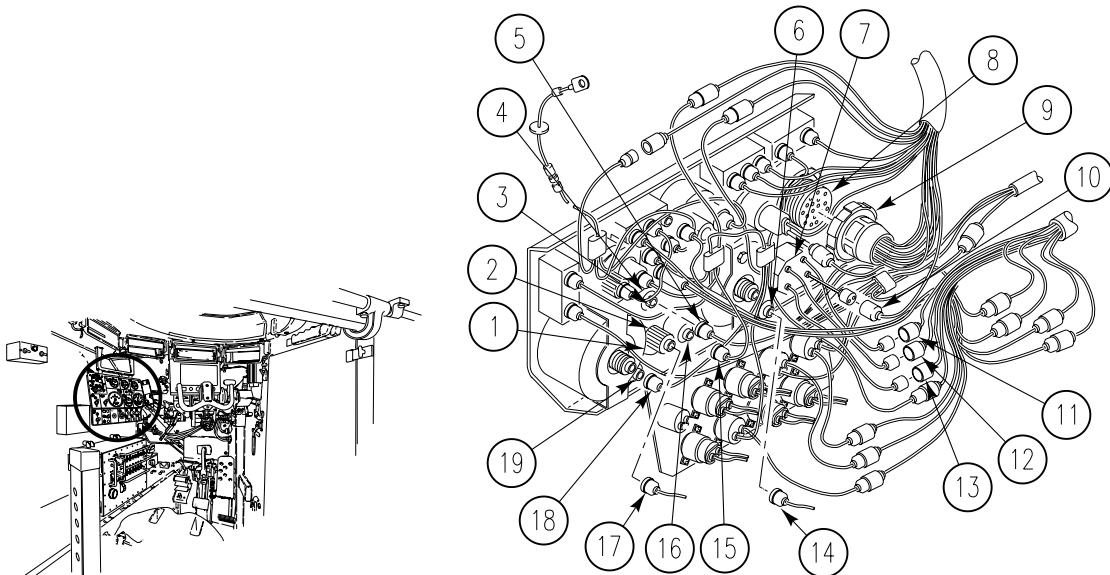

REPLACE INSTRUMENT PANEL ASSEMBLY (M58 ONLY) — Continued

0279 01

5. Disconnect lead 33 (17) and special purpose harness lead 27B (1) from engine coolant temperature gauge (2).
6. Disconnect two circuit 40 leads (5) and (3) from lamp assembly (4).
7. Disconnect special purpose harness lead 459 (18) from master switch indicator (19).

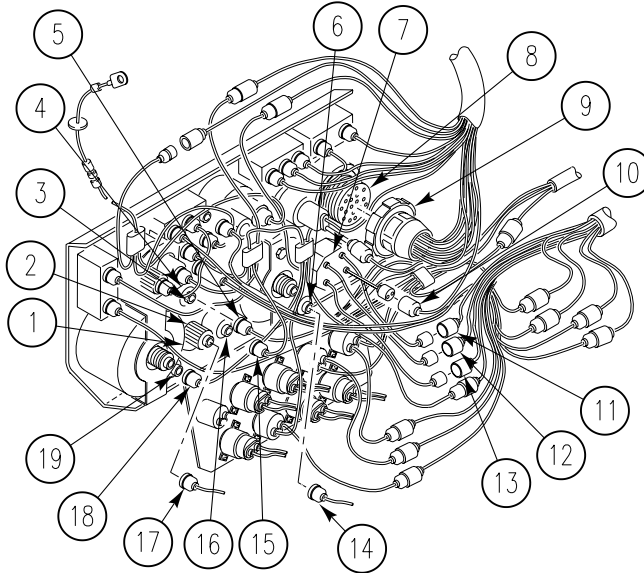

8. Disconnect lead 14B (11) from start switch lead 14 (12).
9. Disconnect lead 74 (10) and lead 14 (12) from start switch (13).
10. Disconnect front main harness 516A lead (8) and special purpose harness lead 516 (6) from DTV switch (7).

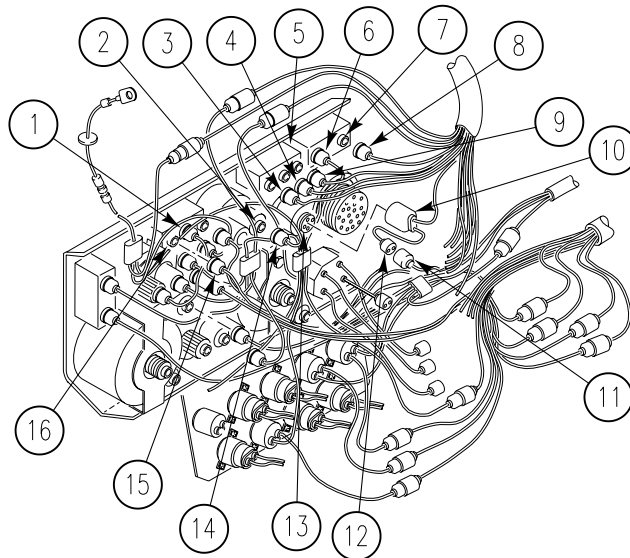

11. Disconnect lead 514/515 (3), lead 520 (4), and lead 19 (9) from infrared blackout switch (5).
12. Disconnect battery/generator harness lead 27E (14) from battery/generator gauge (2).
13. Disconnect battery/generator harness lead 10A (15) and special purpose harness lead 27 (1) from circuit breaker (16).

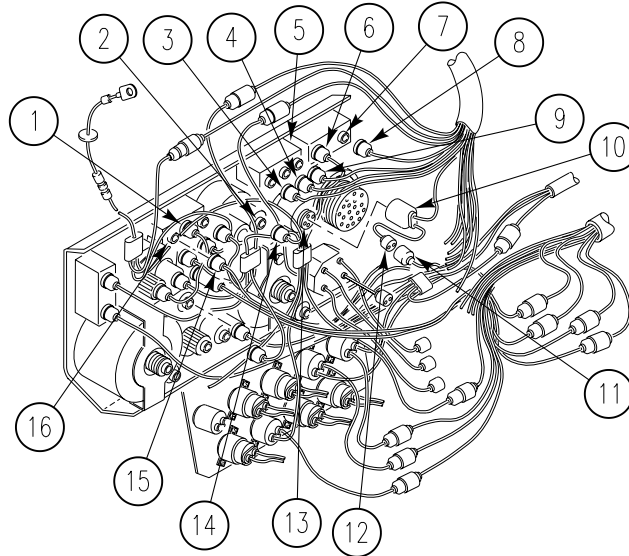

14. Disconnect lead 31 (17) and lead 30 (18) from fuel tank switch (19).
15. Disconnect lead 406 (20) and special purpose harness lead 27C (21) from glow plug switch (39).
16. Remove knurled nut (40) and glow plug indicator (41).
17. Disconnect lead 25A (23), lead 27F (24), lead 27P (25), and lead 38 (26) from special purpose cable (27).

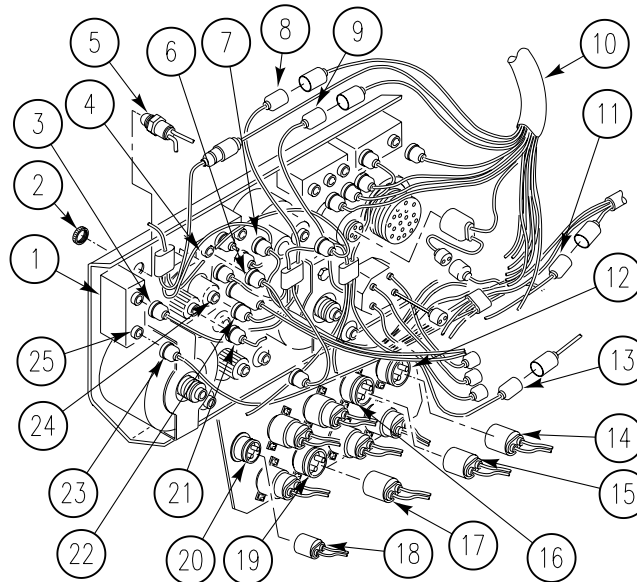

REPLACE INSTRUMENT PANEL ASSEMBLY (M58 ONLY) — Continued

0279 01

18. Disconnect lead 323/27R (28) from transmission oil clogged indicator (29).
19. Disconnect lead 367/27L (30) from transmission low oil pressure indicator (31).
20. Disconnect lead 370/27M (32) from parking brake indicator (33).
21. Disconnect lead 519/519A (34) from headlight HI beam indicator (35).
22. Disconnect special purpose harness lead 27A (36) and lead 28 (37) from fuel gauge (38).

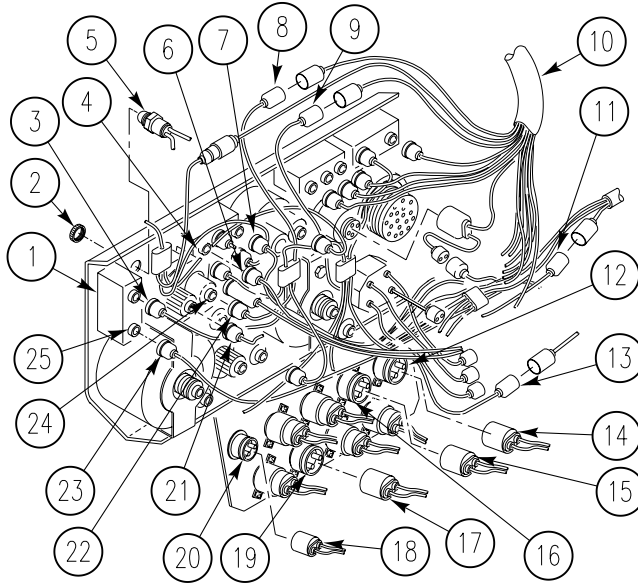

23. Disconnect lead 327/27G (1) from transmission HI temperature indicator (2).
24. Disconnect lead 369A/GND (3) from steering locked indicator (4).
25. Disconnect lead 27J/34 (5) from engine low oil pressure indicator (6).
26. Disconnect lead 352/27K (7) from engine low coolant level indicator (8).
27. Disconnect lead 25/25A (9) from horn switch (10).

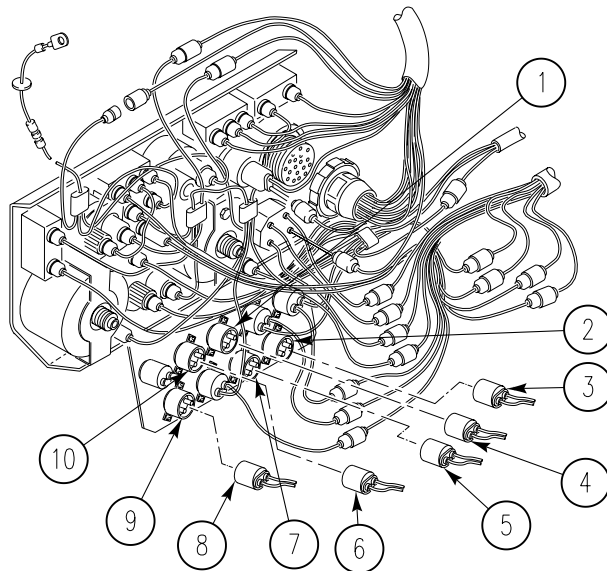

INSTALLATION

1. Connect lead 519/519A (1) to headlight HI beam indicator (2).
2. Connect lead 370/27M (3) to parking brake indicator (4).
3. Connect lead 367/27L (5) to transmission low oil pressure indicator (6).
4. Connect lead 323/27R (7) to transmission oil clogged indicator (8).

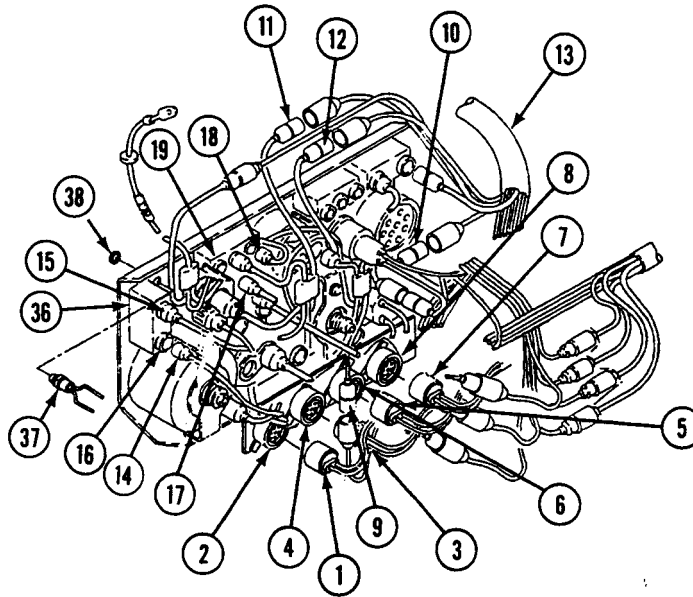

REPLACE INSTRUMENT PANEL ASSEMBLY (M58 ONLY) — Continued

0279 01

5. Connect lead 38 (9), lead 27P (10), lead 25A (11), and lead 27F (12) to special purpose cable (13).
6. Connect lead 406 (14) and special purpose harness lead 27C (15) to glow plug switch (36).
7. Install glow plug indicator (37) and secure with knurled nut (38).
8. Connect lead 31 (17) and lead 30 (18) to fuel tank switch (19).

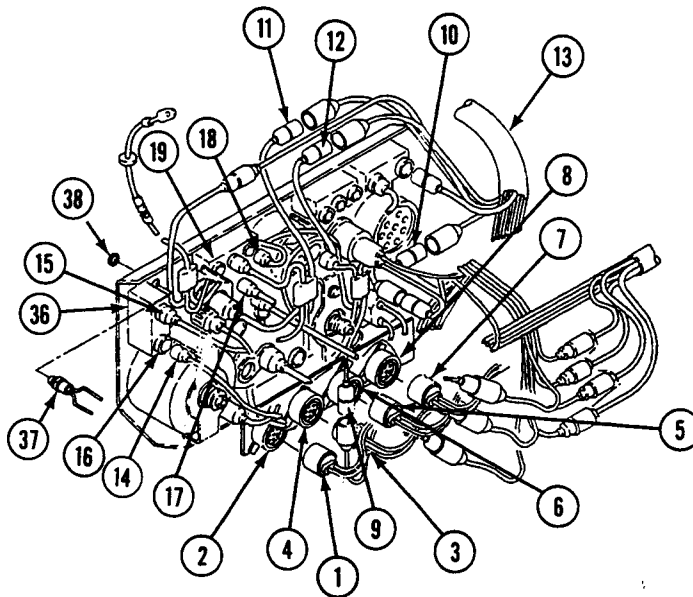

9. Connect battery/generator harness lead 10A (20) and special purpose harness lead 27 (21) to circuit breaker (22).
10. Connect battery/generator harness lead 27E (23) to battery/generator gauge (24).
11. Connect lead 514 (25), lead 520 (26), and lead 19 (27) to infrared blackout switch (28).

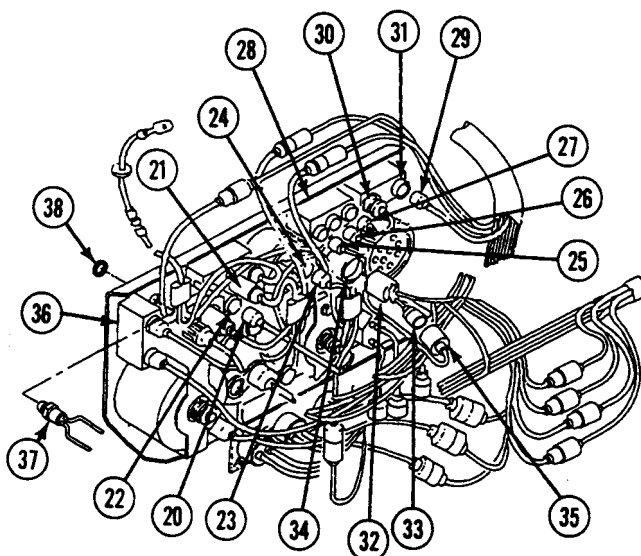

REPLACE INSTRUMENT PANEL ASSEMBLY (M58 ONLY) — Continued

0279 01

12. Connect front main harness 516A (29) and special purpose harness lead 516 (30) to DTV switch (31).
13. Connect lead 74 (32) and lead 14 (33) to start switch (34).
14. Connect lead 14B (35) to start switch lead 14 (33).

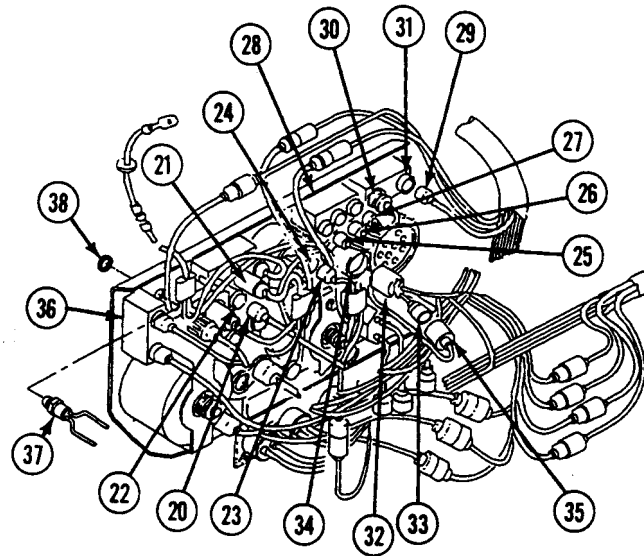

15. Connect two circuit 40 leads (1) and (2) to lamp assembly (3).
16. Connect lead 33 (4) and special purpose harness lead 27B (5) to engine coolant temperature gauge (6).
17. Connect front main harness connector (7) to main light switch (8).
18. Connect lead 450B (9), lead 450 (10), lead 451A (11), and lead 452A (12) to bilge pump switch (13).

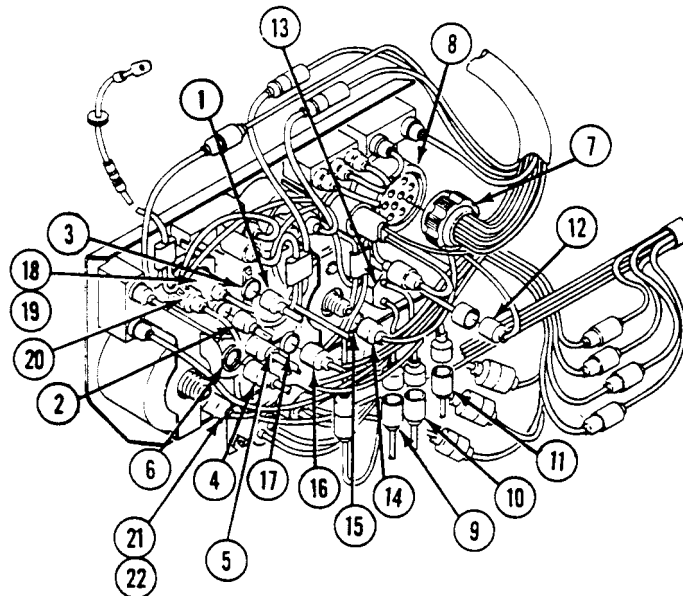

REPLACE INSTRUMENT PANEL ASSEMBLY (M58 ONLY) — Continued

0279 01

19. Connect lead 452B (14) to bilge front pump ON indicator (15).
20. Connect lead 451B (16) to rear bilge pump ON indicator (17).
21. Connect special purpose harness lead 27A (18) and lead 28 (19) to fuel gauge (20).
22. Connect special purpose harness lead 459 (21) to master switch indicator (22).

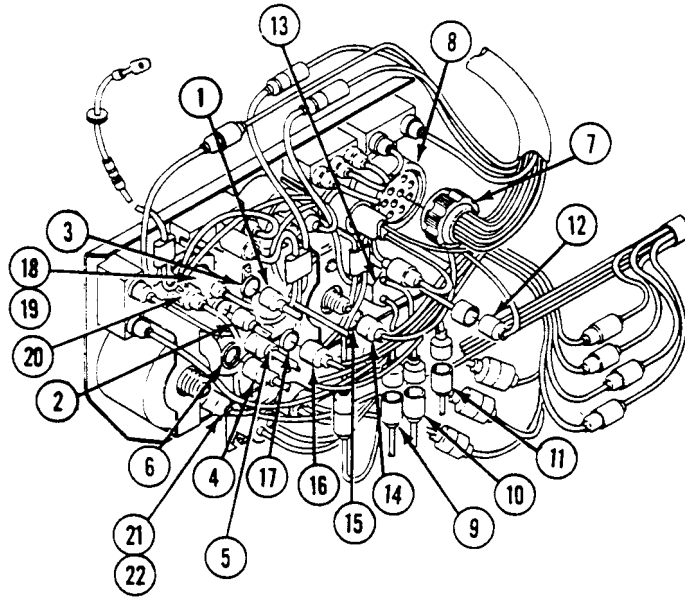

23. Connect lead 327/27G (1) to transmission HI temperature indicator (2).
24. Connect lead 369A/GND (3) to steering locked indicator (4).
25. Connect lead 27J/34 (5) to engine low oil pressure indicator (6).
26. Connect lead 352/27K (7) to engine low coolant level indicator (8).
27. Connect lead 25/25A (9) to horn switch (10).

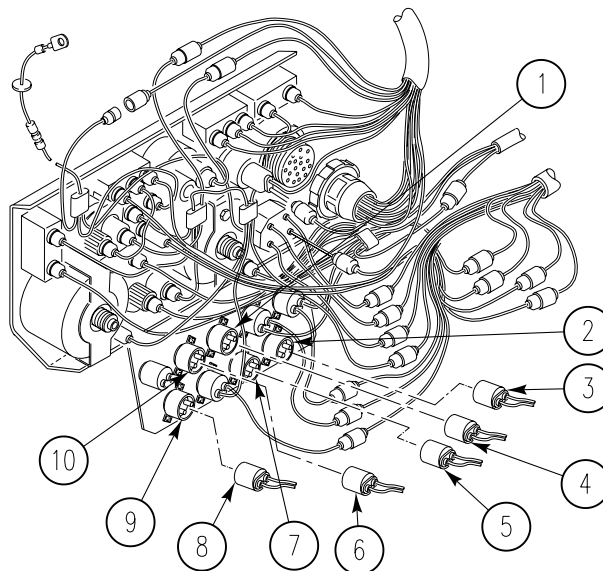

FOLLOW-THROUGH STEPS

1. Install two ground leads, mounts, and instrument panel on struts (WP 0295 00).
2. Install tachometer and speedometer cables on instrument panel gauges (WP 0858 00).
3. Connect battery ground strap (WP 0337 00).

END OF TASK

REPLACE CIRCUIT BREAKER

0280 00

THIS WORK PACKAGE COVERS:

Removal (page 0280 00-1).
 Installation (page 0280 00-2).

INITIAL SETUP:

Maintenance Level

Unit

References

See your -10

Tools and Special Tools

General Mechanic's Tool Kit (WP 0926 00, Item 65)

Equipment Condition

Engine stopped (see your -10)
 Carrier blocked (see your -10)
 Battery ground strap disconnected (WP 0337 00),
 (WP 0338 00), or (WP 0339 00)
 Instrument panel removed (WP 0295 00)

Materials/Parts

Locknut (2)

Personnel Required

Unit Mechanic

REMOVAL

1. Disconnect circuit 10 lead (1) and circuit 27 lead (2) from circuit breaker (3).
2. Remove two locknuts (4), screws (5), and circuit breaker (3) from rear of instrument panel. Discard locknuts.

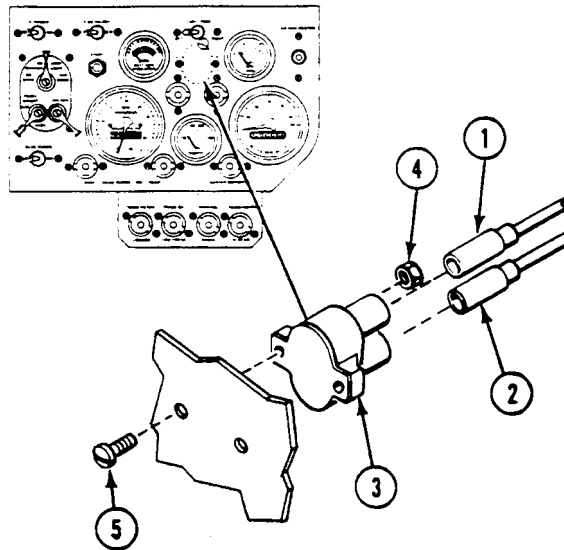

INSTALLATION

1. Place circuit breaker (3) on rear of instrument panel. Secure with two screws (5) and new locknuts (4).
2. Connect circuit 27 lead (2) and circuit 10 lead (1) to circuit breaker (3).

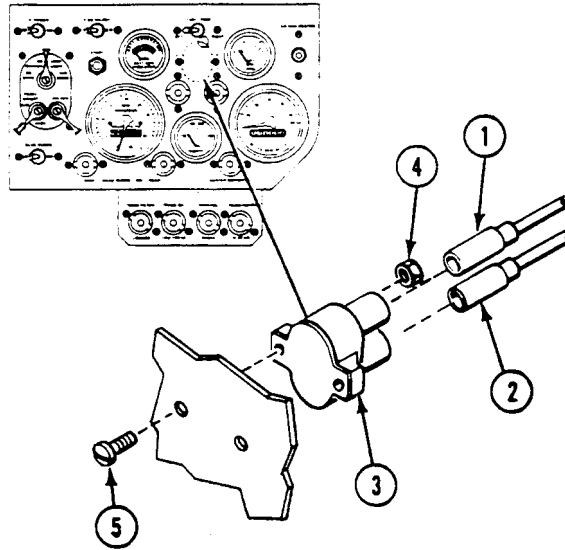
**FOLLOW-THROUGH STEPS**

1. Install instrument panel (WP 0295 00).
2. Connect battery ground strap (WP 0337 00), (WP 0338 00), or (WP 0339 00).
3. Turn MASTER SWITCH to ON (see your -10). MASTER SWITCH ON light should come on (see your -10).
4. Turn MASTER SWITCH to OFF (see your -10).

END OF TASK

REPLACE FUEL SELECT SWITCH TO GAUGE LEAD (ALL EXCEPT M577A3 AND M1068A3)

0281 00

THIS WORK PACKAGE COVERS:

- Removal (page 0281 00-1).
- Inspection and Repair (page 0281 00-2).
- Installation (page 0281 00-2).

INITIAL SETUP:

Maintenance Level

Unit

References

See your -10

Tools and Special Tools

- General Mechanic's Tool Kit (WP 0926 00, Item 65)
- Multimeter (WP 0926 00, Item 30)

Equipment Condition

- Engine stopped (see your -10)
- Carrier blocked (see your -10)
- Battery ground strap disconnected (WP 0337 00), or (WP 0339 00)
- Instrument panel removed (WP 0279 00)

Personnel Required

Unit Mechanic

REMOVAL

1. Disconnect circuit 28 lead (1) from fuel select switch (2).
2. Disconnect circuit 28 lead (1) from fuel gauge (3). Remove lead.

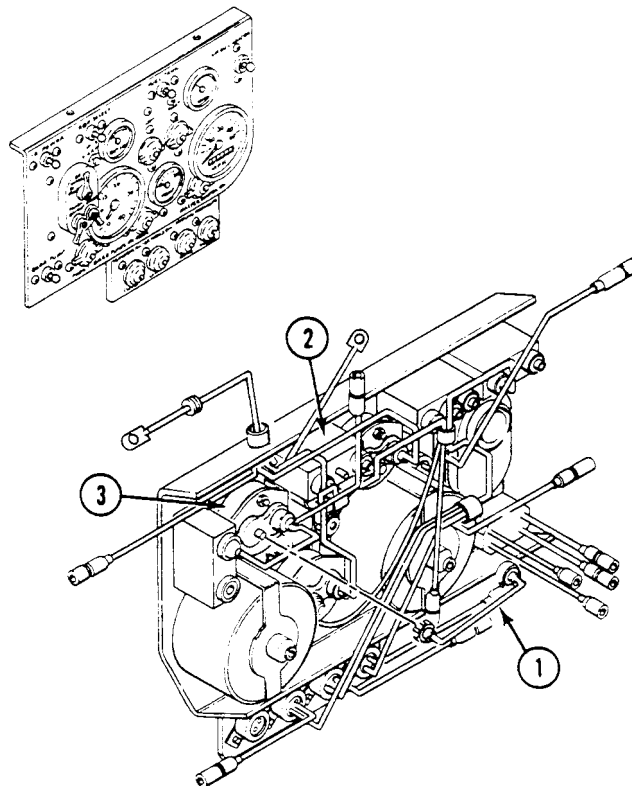

REPLACE FUEL SELECT SWITCH TO GAUGE LEAD (ALL EXCEPT M577A3 AND M1068A3) — Continued

0281 00

INSPECTION-ACCEPTANCE AND REJECTION CRITERIA

1. Check lead for continuity. Check for frayed lead and damaged connectors. Repair as required (WP 0382 00)

INSTALLATION

1. Connect circuit 28 lead (1) to fuel gauge (3).
2. Connect circuit 28 lead (1) to fuel select switch (2).

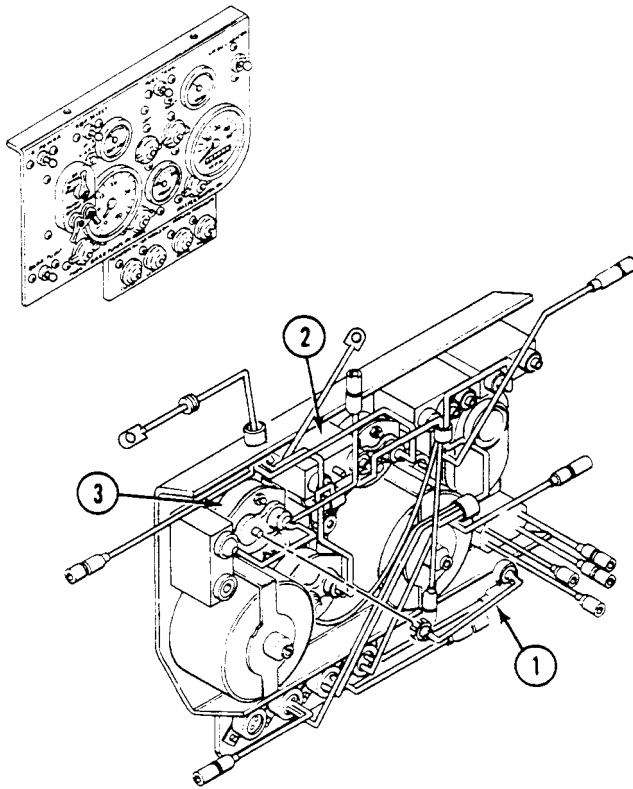
**FOLLOW-THROUGH STEPS**

1. Install instrument panel (WP 0279 00).
2. Connect battery ground lead (WP 0337 00), (WP 0338 00), or (WP 0339 00).
3. Turn MASTER SWITCH ON (see your -10).
4. Check fuel gauge for movement to ensure proper installation of lead (see your -10).
5. Turn MASTER SWITCH OFF (see your -10).

END OF TASK

REPLACE INSTRUMENT PANEL ON-OFF SWITCHES

0282 00

THIS WORK PACKAGE COVERS:

Removal (page 0282 00-1).
 Installation (page 0282 00-3).

INITIAL SETUP:

Maintenance Level

Unit

References

See your -10

Tools and Special Tools

General Mechanic's Tool Kit (WP 0926 00, Item 65)

Equipment Condition

Engine stopped (see your -10)

Carrier blocked (see your -10)

Materials/Parts

Lockwasher (10)

Battery ground strap disconnected (WP 0337 00),
 (WP 0338 00), or (WP 0339 00)

Personnel Required

Unit Mechanic

REMOVAL

NOTE

There are four or five toggle switches on the instrument panel. Replace all toggle switches the same way, except for number of circuit leads, and guard on DNV-POWER switch (all except DVE switch M58 only).

NOTE

Do not disconnect more than one switch at a time. Mark each circuit lead to make sure you reconnect to correct contacts. See applicable wiring diagram at end of this manual.

1. Disconnect circuit leads (1) from rear of switch (2).

2. Remove two screws (3), lockwashers (4), toggle switch (2), and guard (5) (DNV-POWER switch only) from instrument panel. Discard lockwashers.

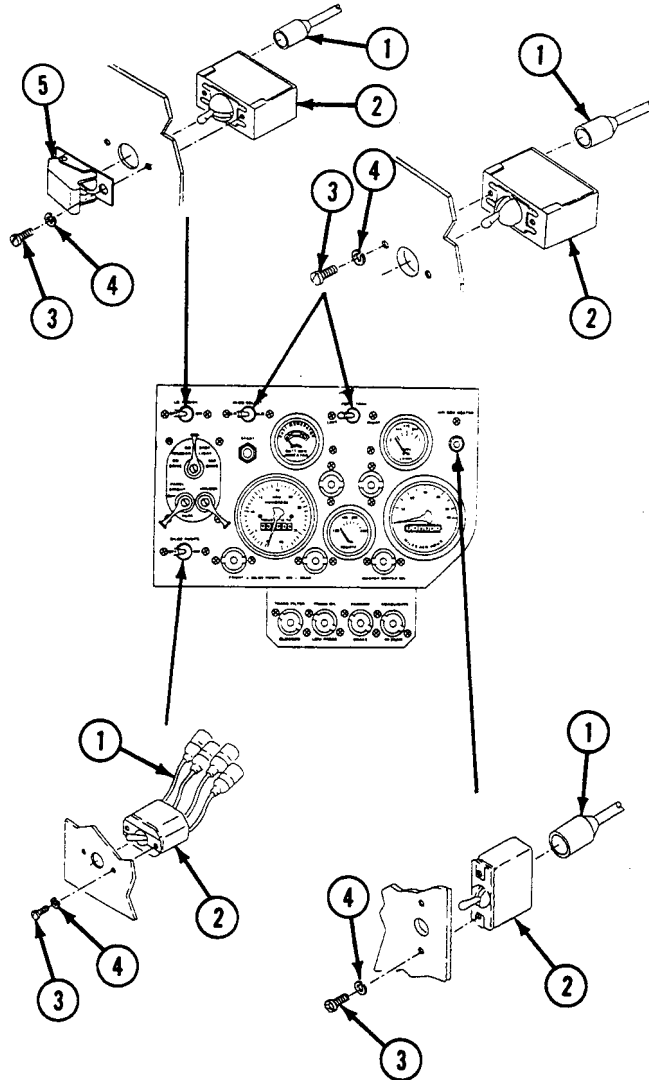

INSTALLATION

1. Place toggle switch (2) on rear of instrument panel. Secure with guard (5) (DNV-POWER switch only), two new lockwashers (4), and screws (3).

NOTE

Make sure circuit leads are connected to correct switches. See Table of Contents for applicable wiring diagram.

2. Connect circuit leads (1) to rear of toggle switch (2).

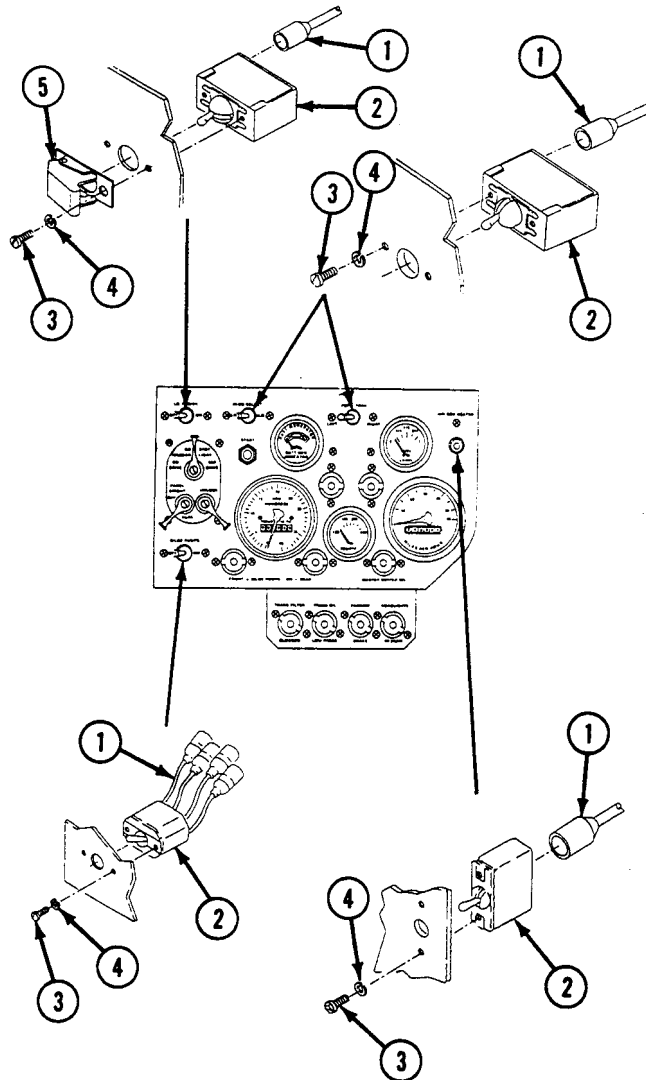

FOLLOW-THROUGH STEPS

1. Connect battery ground strap (WP 0337 00), (WP 0338 00), or (WP 0339 00).
2. Turn MASTER SWITCH to ON (see your -10).
3. Actuate switch and check for proper operation of applicable item (see your -10).
4. Turn MASTER SWITCH to OFF (see your -10).

END OF TASK

REPLACE MAIN LIGHT SWITCH

0283 00

THIS WORK PACKAGE COVERS:

Removal (page 0283 00-1).
 Installation (page 0283 00-2).

INITIAL SETUP:

Maintenance Level

Unit

References

See your -10

Tools and Special Tools

General Mechanic's Tool Kit (WP 0926 00, Item 65)

Equipment Condition

Engine stopped (see your -10)
 Carrier blocked (see your -10)
 Battery ground strap disconnected (WP 0337 00),
 (WP 0338 00), or (WP 0339 00)
 Instrument panel removed (WP 0295 00)

Personnel Required

Unit Mechanic

REMOVAL

1. Disconnect cable (1) from main light switch (2).
2. Remove screw (3), washer (4), and switch lever (5) from light switch (2).
3. Remove four screws (6) and light switch (2) from instrument panel.

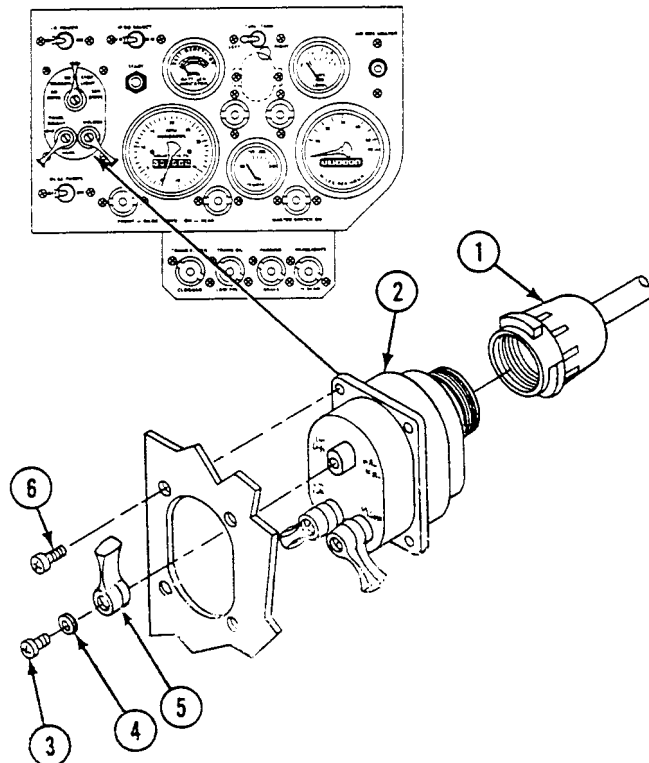

INSTALLATION

1. Place main light switch (2) in rear of instrument panel. Secure with four screws (6).
2. Place switch lever (5) on light switch (2). Secure with washer (4) and screw (3).
3. Connect cable (1) to rear of light switch (2).

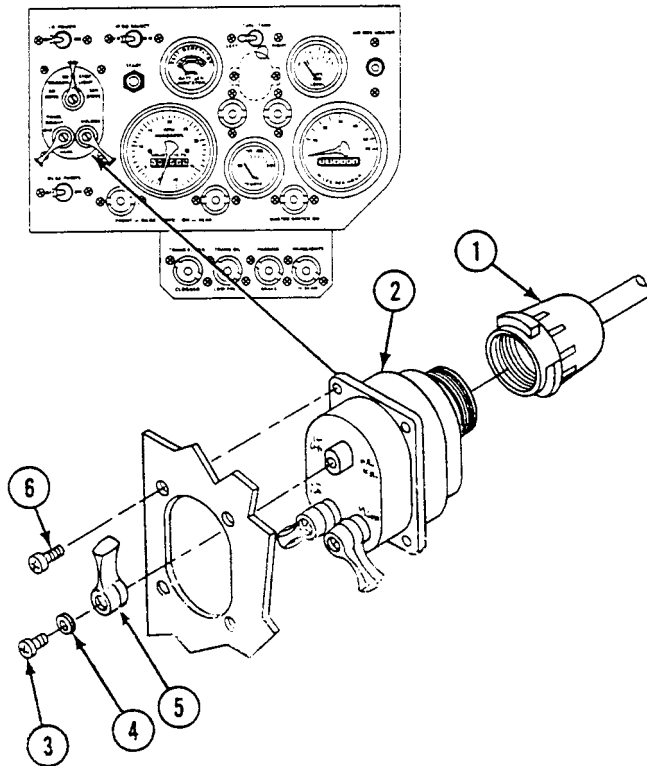
**FOLLOW-THROUGH STEPS**

1. Install instrument panel (WP 0295 00).
2. Connect battery ground strap (WP 0337 00), (WP 0338 00), or (WP 0339 00).
3. Turn MASTER SWITCH to ON (see your -10).
4. Check for proper operation of switch (see your -10).
5. Turn MASTER SWITCH to OFF (see your -10).

END OF TASK

REPLACE ENGINE START SWITCH

0284 00

THIS WORK PACKAGE COVERS:

Removal (page 0284 00-1).
 Installation (page 0284 00-2).

INITIAL SETUP:

Maintenance Level

Unit

References

See your -10

Tools and Special Tools

General Mechanic's Tool Kit (WP 0926 00, Item 65)

Equipment Condition

Engine stopped (see your -10)
 Carrier blocked (see your -10)
 Battery ground strap disconnected (WP 0337 00),
 (WP 0338 00), or (WP 0339 00)

Personnel Required

Unit Mechanic

REMOVAL

1. Remove nut (1) and start switch (2) from instrument panel.
2. Remove lock washer (3) and nut (4) from start switch (2).
3. Disconnect circuit 14/74 connector (5) from rear of start switch (2).

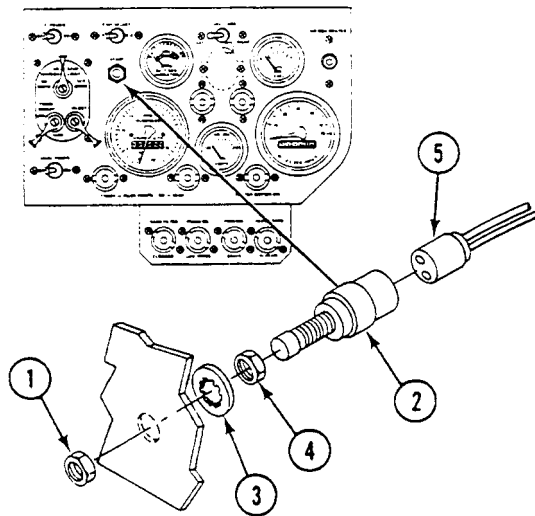

INSTALLATION

1. Connect circuit 14/74 connector (5) to rear of start switch (2).
2. Install nut (4) and lock washer (3) on start switch (2).
3. Install start switch (2) through rear of instrument panel. Secure with two nuts (1) and (4).

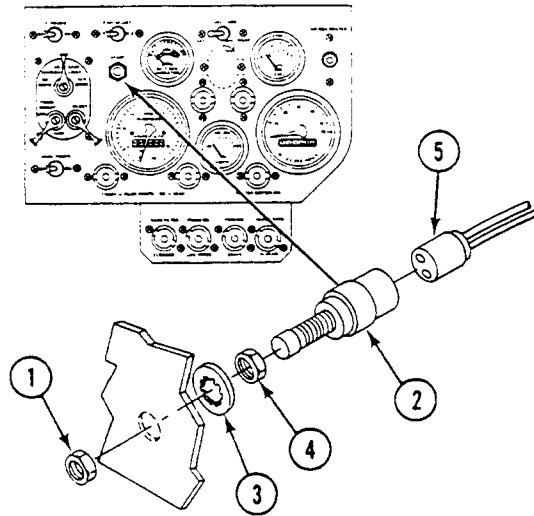
**FOLLOW-THROUGH STEPS**

1. Connect battery ground strap (WP 0337 00), (WP 0338 00), or (WP 0339 00).
2. Turn MASTER SWITCH to ON (see your -10).
3. Crank engine to check for proper installation of starter switch (see your -10).
4. Turn MASTER SWITCH to OFF (see your -10).

END OF TASK

REPLACE INSTRUMENT PANEL GAUGES

0285 00

THIS WORK PACKAGE COVERS:

Removal (page 0285 00-1).
 Installation (page 0285 00-2).

INITIAL SETUP:

Maintenance Level

Unit

References

See your -10

Tools and Special Tools

General Mechanic's Tool Kit (WP 0926 00, Item 65)

Equipment Condition

Engine stopped (see your -10)
 Carrier blocked (see your -10)
 Battery ground strap disconnected (WP 0337 00),
 (WP 0338 00), or (WP 0339 00)

Personnel Required

Unit Mechanic

REMOVAL

NOTE

There are three gauges on the instrument panel. Except for the number of leads, all gauges are replaced the same way.

NOTE

Do not disconnect more than one gauge at a time. Mark each lead to make sure you reconnect to correct contacts. See wiring diagrams at the end of this manual.

1. Disconnect circuit leads (1) from rear of gauge (2).
2. Remove two nuts (3), lockwashers (4), and bracket (5) from rear of gauge (2).
3. Remove gauge (2) from front of instrument panel.

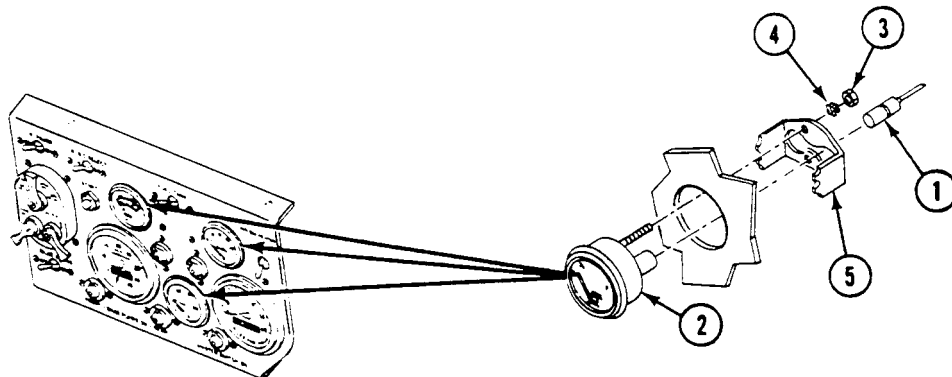

INSTALLATION

1. Install gauge (2) in front of instrument panel.

NOTE

Check front of instrument panel to make sure gauge is aligned right before tightening nuts.

2. Install bracket (5) on rear of gauge, and secure with two lockwashers (4) and nuts (3).

CAUTION

Make sure circuit leads are connected to correct gauges. See wiring diagrams at the end of this manual.

3. Connect circuit leads (1) to rear of gauge (2).

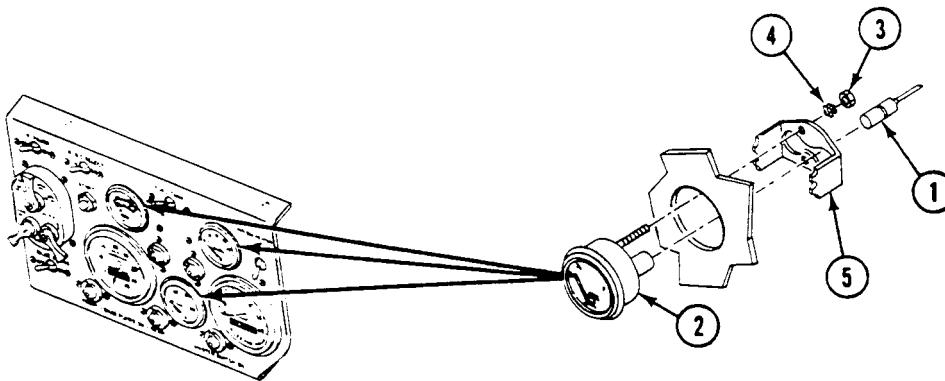
**FOLLOW-THROUGH STEPS**

1. Connect battery ground strap (WP 0337 00), (WP 0338 00), or (WP 0339 00).
2. Turn MASTER SWITCH to ON (see your -10).
3. Check fuel gauge and battery generator gauge for proper operation (see your -10).
4. Start engine to check operation of coolant temperature gage (see your -10).
5. Stop engine (see your -10).

END OF TASK

REPLACE PANEL LIGHTS AND INDICATOR LIGHTS

0286 00

THIS WORK PACKAGE COVERS:

Removal (page 0286 00-1).
 Installation (page 0286 00-3).

INITIAL SETUP:

Maintenance Level
 Unit

References
 See your -10

Tools and Special Tools
 General Mechanic's Tool Kit (WP 0926 00, Item 65)

Equipment Condition

Materials/Parts
 Light bulb (as needed)
 Lockwasher (2)

Engine stopped (see your -10)
 Carrier blocked (see your -10)
 Battery ground strap disconnected (WP 0337 00),
 (WP 0338 00), or (WP 0339 00)

Personnel Required
 Unit Mechanic

REMOVAL

NOTE

There are two panel lights and three indicator lights on the instrument panel. Except for the number of leads, all lights are replaced the same way.

1. Remove light bulb (1).

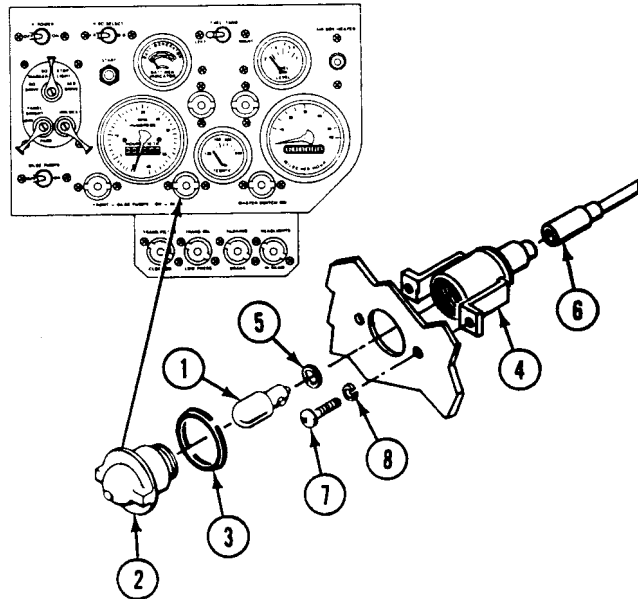

- a. Turn lens (2) to the left. Remove lens and gasket (3) from light assembly (4).
- b. Push in and turn light bulb (1) to the left, and remove bulb and gasket (5) from light assembly (4).

NOTE

Do not disconnect more than one light at a time. Mark each lead to make sure you reconnect to correct contacts. See wiring diagrams at the end of this manual.

2. If required, remove light assembly (4).

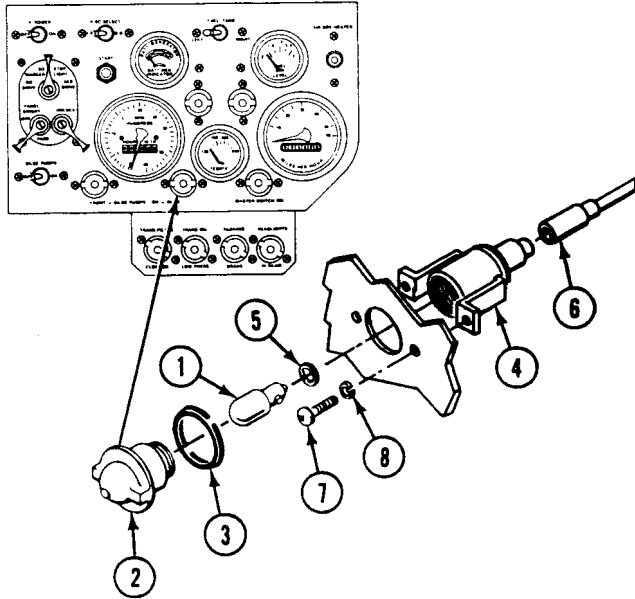

- a. Disconnect circuit lead (6) from light assembly (4).
- b. Remove two screws (7), lockwashers (8), and light assembly (4) from instrument panel. Discard lockwashers.

INSTALLATION

1. If removed, install light assembly (1).
 - a. Place light assembly (1) on rear of instrument panel. Secure with two new lockwashers (2) and screws (3).

CAUTION

Make sure circuit leads are connected to correct lights. See wiring diagrams at the end of this manual.

- b. Connect circuit lead (4) to light assembly (1).
2. Install light bulb (5).

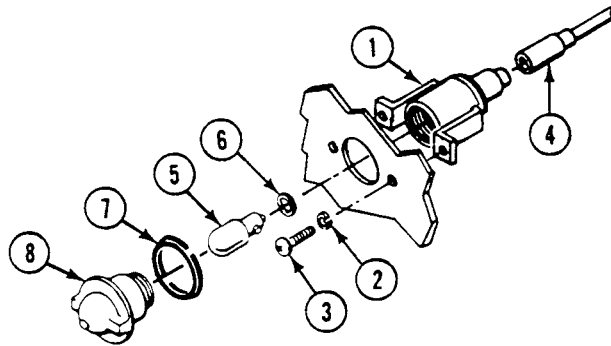

- a. Install gasket (6) and light bulb (5) in light assembly (1). Push and turn light bulb to the right to secure.
 - b. Install gasket (7) and lens (8) in light assembly (1). Turn lens to the right to secure.

FOLLOW-THROUGH STEPS

1. Connect battery ground strap (WP 0337 00), (WP 0338 00), or (WP 0339 00).
2. Turn MASTER SWITCH to ON (see your -10).
3. Turn PANEL lights switch to ON, or BILGE PUMPS switch to ON, as needed, to check for proper installation of light assembly (see your -10).
4. Turn MASTER SWITCH OFF (see your -10).

END OF TASK

REPLACE INSTRUMENT PANEL WARNING LIGHTS

0287 00

THIS WORK PACKAGE COVERS:

- Removal (page 0287 00-2).
- Inspection (page 0287 00-3).
- Installation (page 0287 00-4).

INITIAL SETUP:

Maintenance Level

Unit

References

See your -10

Tools and Special Tools

General Mechanic's Tool Kit (WP 0926 00, Item 65)

Equipment Condition

Engine stopped (see your -10)

Carrier blocked (see your -10)

Materials/Parts

Light bulb (as needed)

Lockwasher (2)

Battery ground strap disconnected (WP 0337 00),
(WP 0338 00), or (WP 0339 00)

Personnel Required

Unit Mechanic

REMOVAL

NOTE

All lights are replaced the same way.

1. Remove light bulb (1).
 - a. Turn lens (2) to the left. Remove lens and gasket (3) from light assembly (4).
 - b. Push in and turn light bulb (1) to the left, and remove bulb and gasket (5) from light assembly (4).

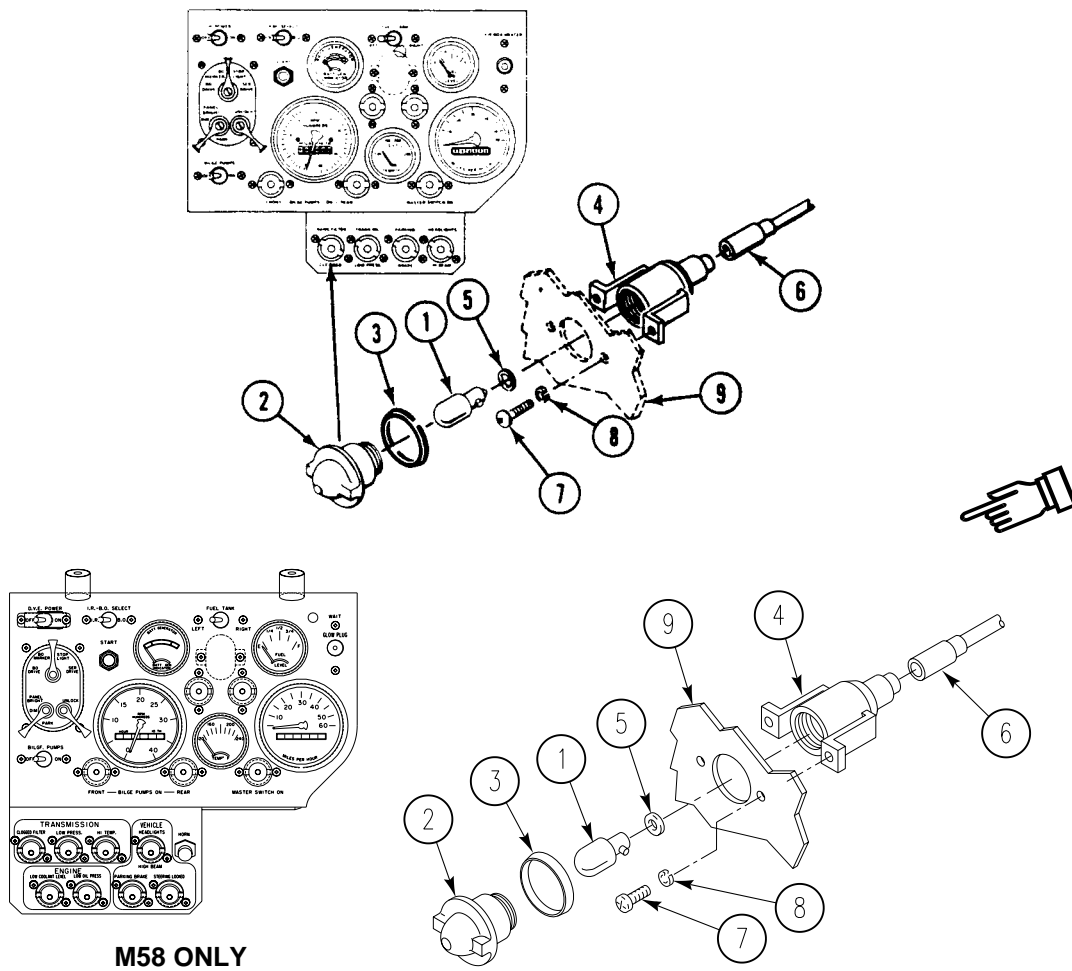

NOTE

Do not disconnect more than one light at a time. Mark each lead to make sure you reconnect to correct contacts. See wiring diagrams at the end of (Vol. 6).

2. If required, remove light assembly (4).
 - a. Disconnect circuit lead (6) from light assembly (4).
 - b. Remove two screws (7), lockwashers (8), and light assembly (4) from warning lights panel (9). Discard lockwashers.

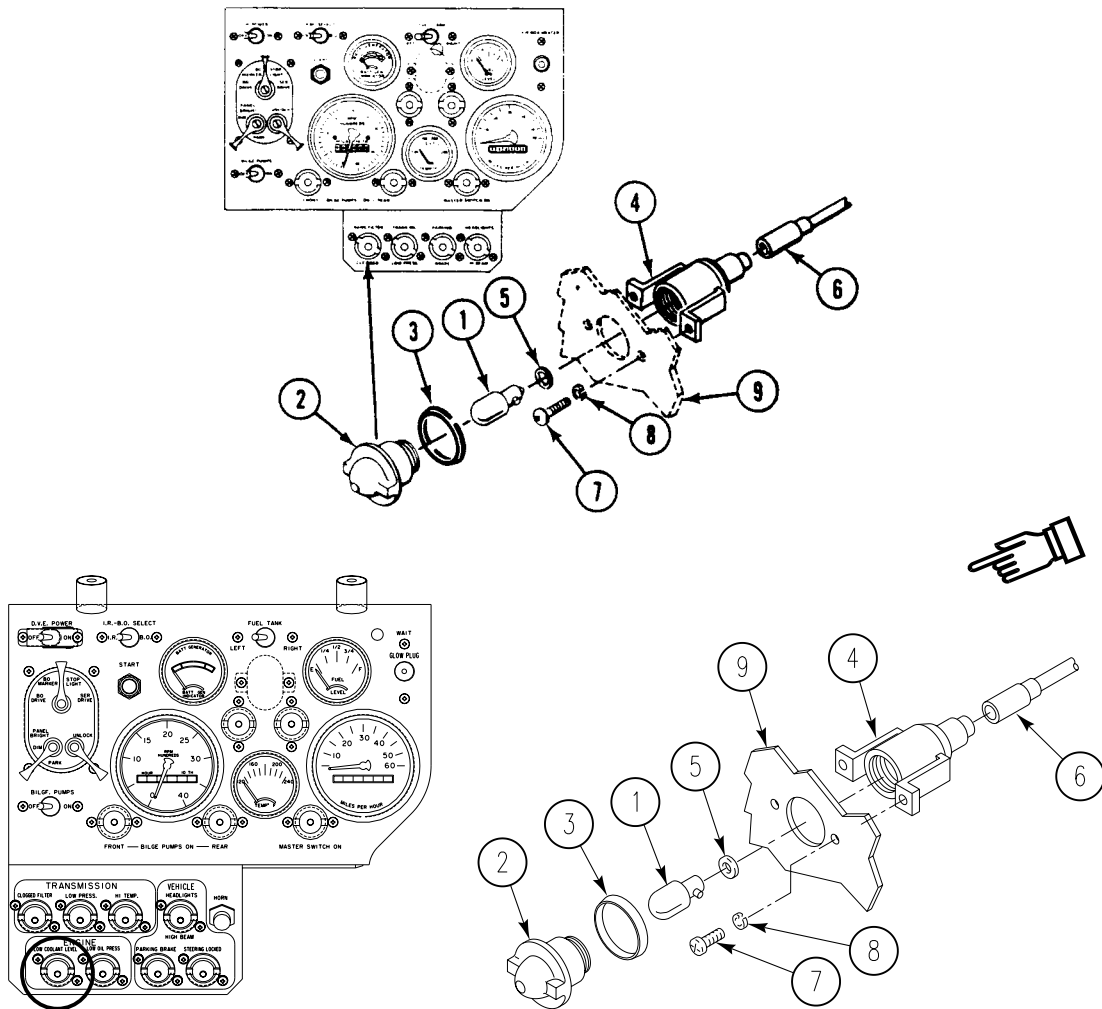

M58 ONLY

INSPECTION-ACCEPTANCE AND REJECTION CRITERIA

1. Check light bulb. See troubleshooting (WP 0006 00). Replace bad light bulb.
2. Check light assembly. See troubleshooting (WP 0006 00). Replace bad light assembly.

INSTALLATION

NOTE

Make sure circuit leads are connected to correct lights. See wiring diagrams at the end (Vol. 6).

1. If removed, install light assembly (4).
 - a. Place light assembly (4) on rear of warning lights panel (9). Secure with two new lockwashers (8) and screws (7).
 - b. Connect circuit lead (6) to light assembly (4).

Install light bulb (1).

- a. Install gasket (5) and light bulb (1) in light assembly (4). Push and turn light bulb to the right to secure.
- b. Install gasket (3) and lens (2) in light assembly (4). Turn lens to the right to secure.

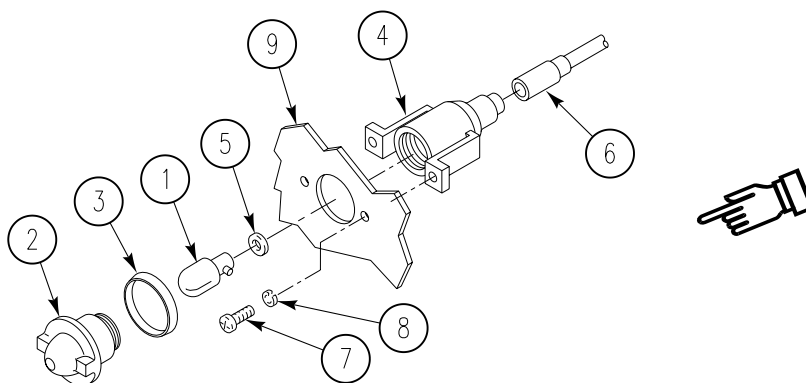

FOLLOW-THROUGH STEPS

1. Connect battery ground strap (WP 0337 00), (WP 0338 00), or (WP 0339 00).
2. Turn MASTER SWITCH to ON (see your -10).
3. Check instrument panel warning lights as follows (see your -10):
 - a. TRANS FILTER CLOGGED light should be off.
 - b. Ground circuit 323 lead at back of panel. TRANS FILTER CLOGGED light should be on. Remove ground.
 - c. TRANS OIL LOW PRESS light should be on.
 - d. PARKING BRAKE light should be on when parking brake is on.
 - e. Turn on headlights and depress high beam selector switch (see your -10). HEADLIGHTS HI BEAM light should be on when headlights are on high beam. Turn off headlights.
 - f. ENGINE COOLANT LOW LEVEL light should be off. It will come on when you ground circuit 352 lead.
 - g. TRANS OIL HI TEMP indicator should be off. It will come on when you ground circuit lead 327.
 - h. ENGINE OIL LOW PRESS indicator should be on.
 - i. STEERING LOCKED indicator should be on when transmission controller is in SL.
4. Turn MASTER SWITCH to OFF (see your -10).

END OF TASK

REPLACE INSTRUMENT WARNING LIGHT PANEL

0288 00

THIS WORK PACKAGE COVERS:

- Removal (page 0288 00-1).
- Installation (page 0288 00-2)

INITIAL SETUP:

Maintenance Level

Unit

References

TM 9-2350-277-10

Tools and Special Tools

General Mechanic's Tool Kit (WP 0926 00, Item 65)

Equipment Condition

Engine stopped (TM 9-2350-277-10)

Carrier blocked (TM 9-2350-277-10)

Materials/Parts

Locknut (2)

Instrument panel warning lights removed (WP 0287 00)

Personnel Required

Unit Mechanic

Replace horn switch (M58 only)

REMOVAL

1. Remove two screws (1), four washers (2), and two locknuts (3). Remove warning light panel (4) from instrument panel. Discard locknuts.

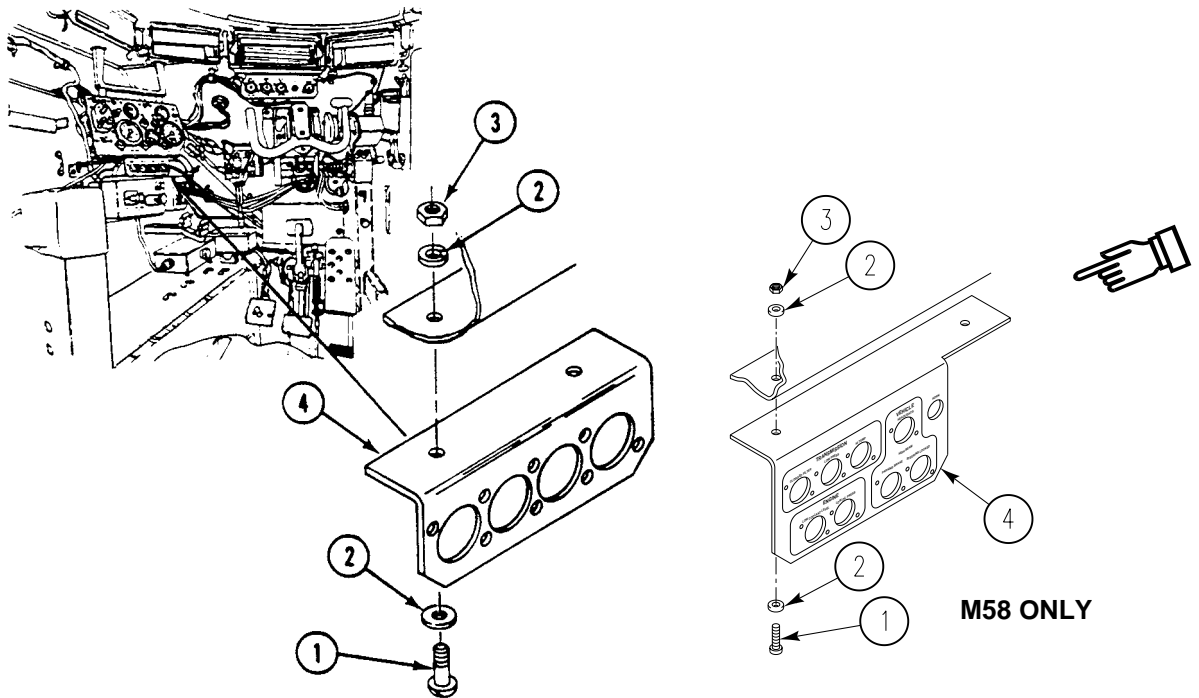

INSTALLATION

1. Position warning light panel (4) on bottom of instrument panel and secure with two screws (1), four washers (2), and two new locknuts (3).

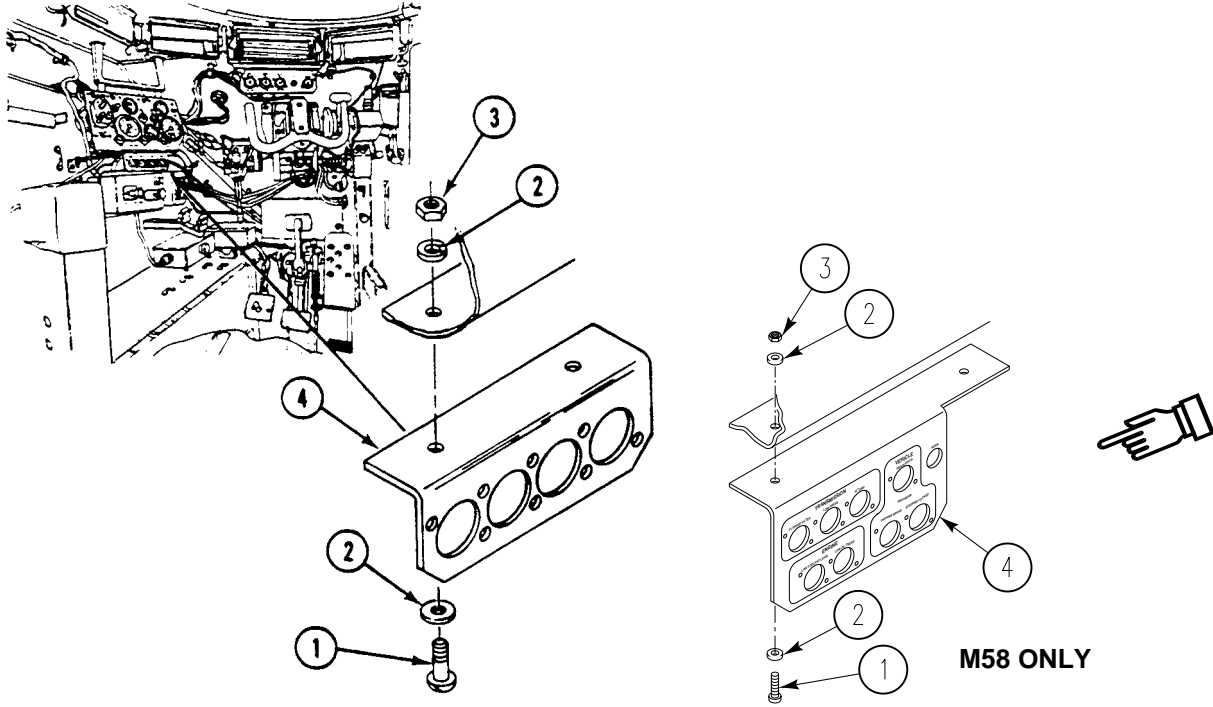

FOLLOW-THROUGH STEPS

1. Install instrument panel warning lights (WP 0287 00).

END OF TASK

**REPLACE INSTRUMENT PANEL BATTERY-GENERATOR GAUGE WIRING
HARNESS**

0289 00

THIS WORK PACKAGE COVERS:

Removal (page 0289 00-2).
Installation (page 0289 00-4).

INITIAL SETUP:

Maintenance Level

Unit

References

See your -10

Tools and Special Tools

General Mechanic's Tool Kit (WP 0926 00, Item 65)

Equipment Condition

Engine stopped (see your -10)

Carrier blocked (see your -10)

Battery ground strap disconnected (WP 0337 00) or
(WP 0338 00)

Tachometer and speedometer disconnected from
instrument panel gages (WP 0859 00) and
(WP 0862 00)

Materials/Parts

Locknut (10)

Lockwasher

Lockwasher

Personnel Required

Unit Mechanic

— Continued

REMOVAL

1. Remove two locknuts (1), mounts (2) and (3), washers (4), and screws (5) that secure instrument panel (6) to two struts (7). Discard locknuts.

NOTE

The M58 vehicle (not shown) has four ground leads and the warning light panel has more indicator lights.

2. Support panel (6). Remove two screws (8), washers (9), one lockwasher (10), and ground straps (11) from two mounts (12) and upper support (13). Discard lockwasher.
3. Support panel (6) on two struts (7) to gain access to rear of panel.

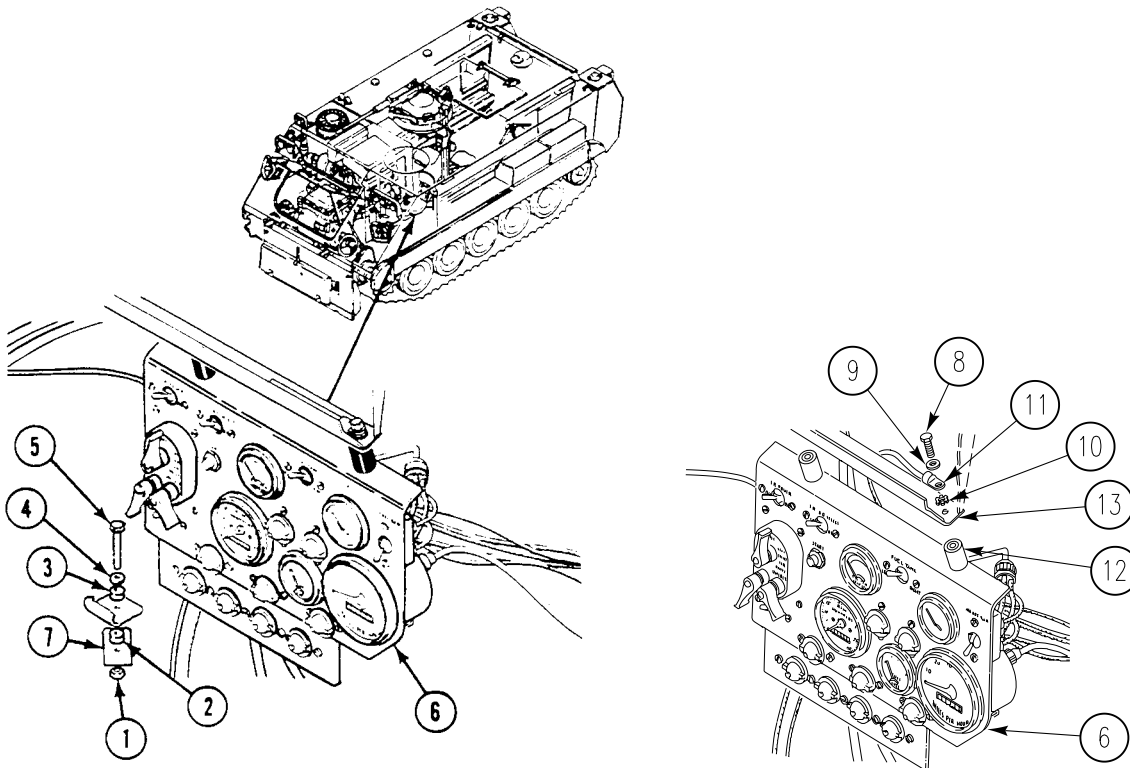

REPLACE INSTRUMENT PANEL BATTERY-GENERATOR GAUGE WIRING HARNESS

0289 00

— Continued

4. Disconnect circuit 15 lead (1) from instrument panel wiring harness (2).
5. Disconnect circuit 10 lead (3) from panel circuit breaker (4).
6. Disconnect circuit 27E lead (5) from battery generator gage (6).
7. Remove panel wiring harness (2) from instrument panel (7).
8. Remove eight locknuts (8), washers (9), and screws (10). Separate master switch panel (11) from distribution box (12). Discard locknuts.
9. Remove screw (13), lockwasher (14), circuit 450A lead (15), and harness lead (16) from bus bar (17). Discard lockwasher.
10. Remove panel wiring harness lead (16) from distribution box (12).

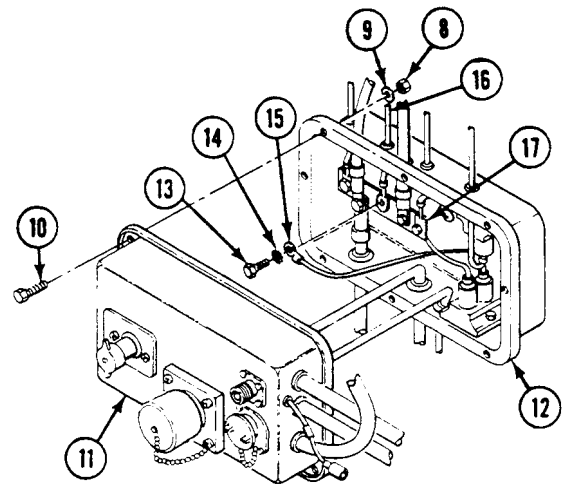
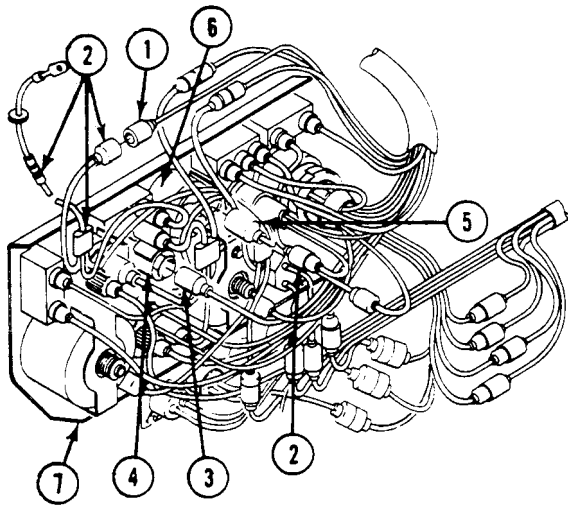

REPLACE INSTRUMENT PANEL BATTERY-GENERATOR GAUGE WIRING HARNESS

0289 00

— Continued

INSTALLATION

1. Install harness lead (16) through hole in top of distribution box (12). Secure harness lead and circuit 450A lead (15) to bus bar (17) with new lockwasher (14) and screw (13).
2. Install master switch panel (11) on distribution box (12). Secure with eight screws (10), washers (9), and new locknuts (8).
3. Connect circuit 27E lead (5) to battery generator gage (6).
4. Connect circuit 10 lead (3) to instrument panel circuit breaker (4).
5. Connect circuit 15 lead (1) to panel wiring harness (2).

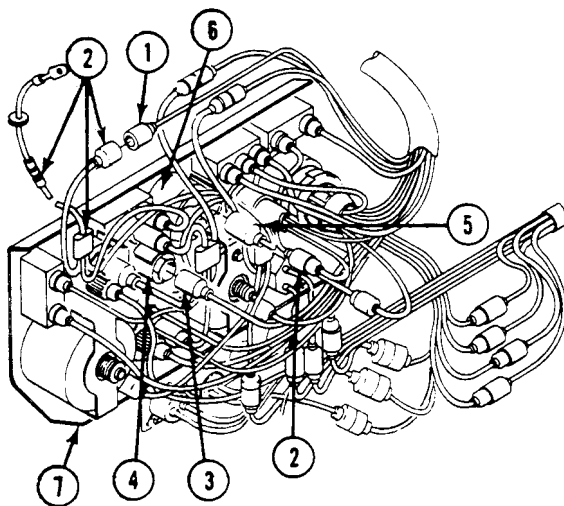
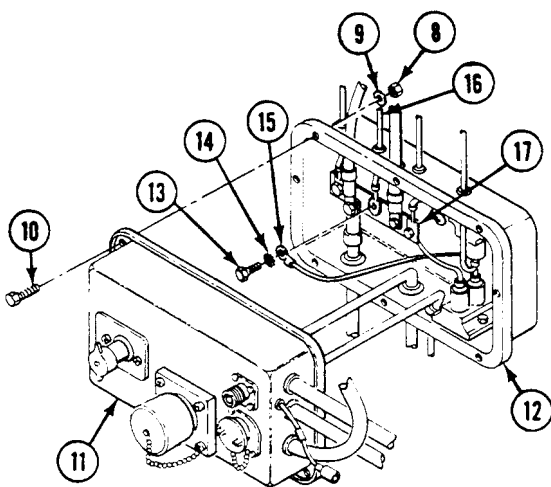

REPLACE INSTRUMENT PANEL BATTERY-GENERATOR GAUGE WIRING HARNESS**0289 00**

— Continued

NOTE

The M58 vehicle (not shown) has four ground leads and the warning light panel has more indicator lights.

6. Support instrument panel (6) on two struts (7).
7. Install two screws (8), washers (9), new lockwasher (10), and ground straps (11) on two mounts (12) and upper support (13).
8. Install two new locknuts (1), mounts (2) and (3), washers (4), screws (5), and struts (7) on instrument panel (6).

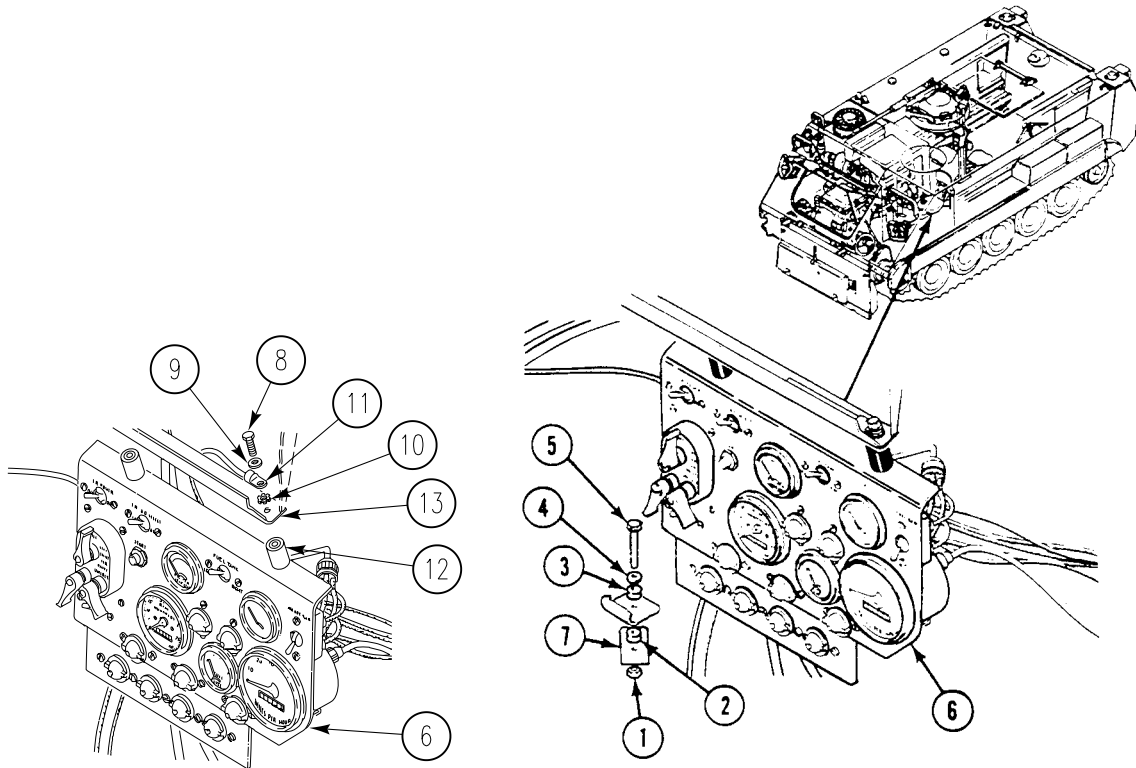
**FOLLOW-THROUGH STEPS**

1. Connect tachometer and speedometer to instrument panel gauges (WP 0859 00) and (WP 0862 00).
2. Connect battery ground strap (WP 0337 00) or (WP 0338 00).
3. Turn MASTER SWITCH to ON (see your -10). Check that battery generator gage operates properly.
4. Turn MASTER SWITCH to OFF (see your -10).

END OF TASK

REPLACE INSTRUMENT PANEL SPECIAL PURPOSE CABLE

0290 00

THIS WORK PACKAGE COVERS:

Removal (page 0290 00-1).
 Installation (page 0290 00-5).

INITIAL SETUP:

Maintenance Level

Unit

References

See your -10

Tools and Special Tools

General Mechanic's Tool Kit (WP 0926 00, Item 65)

Equipment Condition

Engine stopped (see your -10)
 Carrier blocked (see your -10)
 Battery ground strap disconnected (WP 0337 00),
 (WP 0338 00), or (WP 0339 00)
 Cables disconnected from speedometer and tachometer
 (WP 0859 00) and (WP 0862 00)

Materials/Parts

Lockwasher

Personnel Required

Unit Mechanic

REMOVAL

1. Remove two nuts (1), mounts (2) and (3), washers (4), and screws (5) that secure instrument panel (6) to two struts (7).
2. Support panel (6). Remove two screws (8), washers (9), one lockwasher (10), and ground lead (11) from two mounts (12) and upper support (13). Discard lockwasher.
3. Support panel (6) on two struts (7) to gain access to rear of panel.

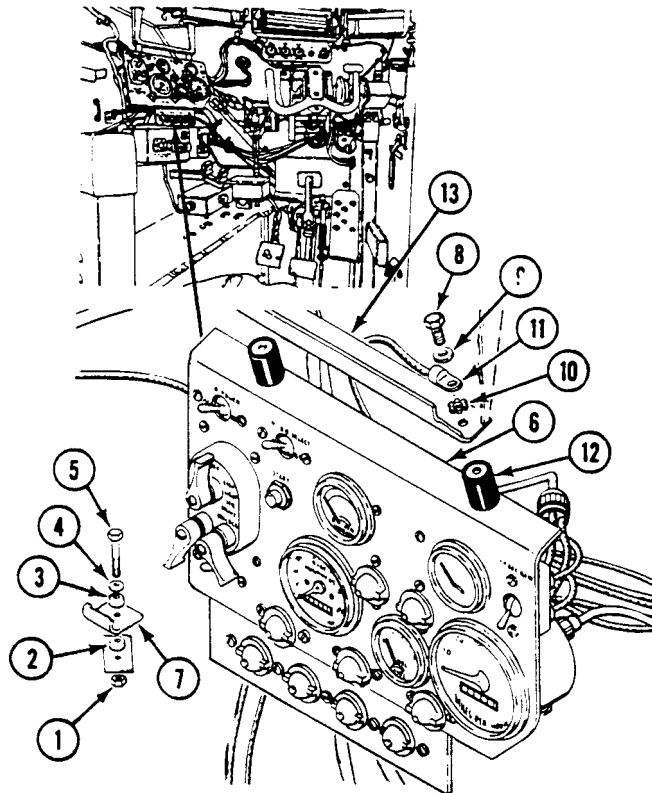

NOTE

All wiring harnesses except special purpose cable removed for clarity.

NOTE

All leads are shown from the back of the instrument panel.

4. Disconnect circuit lead 38 (1) from instrument panel wiring harness.
5. Disconnect circuit 25A lead (2) from panel wiring harness.
6. Disconnect circuit 27F lead (3) from panel wiring harness.
7. Disconnect circuit 27C lead (4) from AIR BOX HEATER switch (5).
8. Disconnect circuit 27B lead (6) from engine coolant temperature gauge (7).

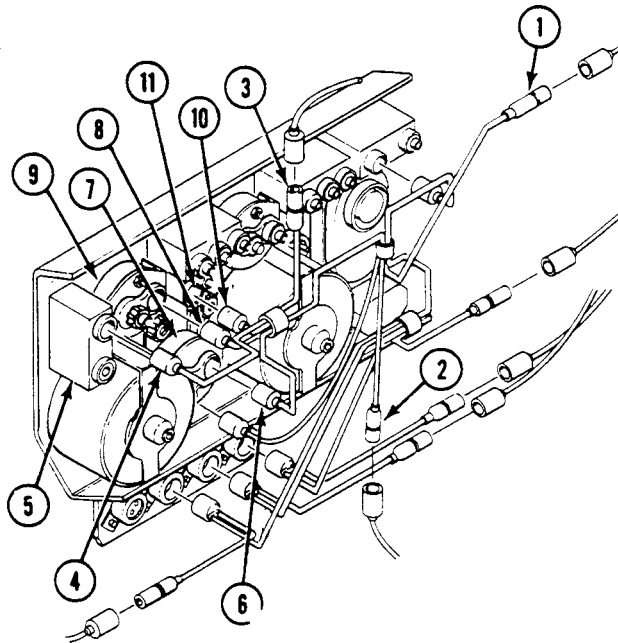

9. Disconnect circuit 27A lead (8) from fuel quantity gauge (9).
10. Disconnect circuit 27 lead (10) from instrument panel circuit breaker (11).
11. Disconnect circuit 459 lead (12) from MASTER SWITCH ON indicator light (13).
12. Disconnect circuit 516 lead (14) from IR POWER or DTV (M58 only) switch (15).
13. Disconnect circuit 323 lead (16) from instrument panel wiring harness.
14. Disconnect circuit 323 and 27R leads (17) from TRANS FILTER CLOGGED indicator (18).
15. Disconnect circuit 367 lead (19) from panel wiring harness.

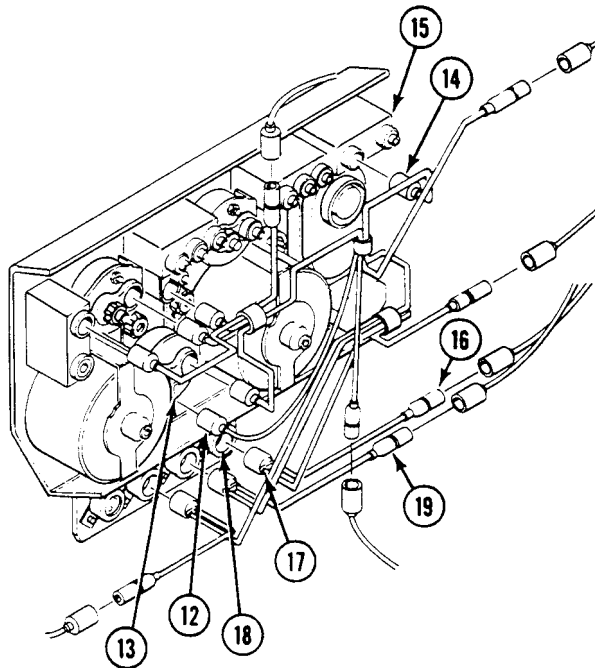

REPLACE INSTRUMENT PANEL SPECIAL PURPOSE CABLE — Continued

0290 00

16. Disconnect circuit 367 and 27L leads (1) from TRANS OIL LOW PRESS indicator (2).
17. Disconnect circuit 370 lead (3) from panel wiring harness.
18. Disconnect circuit 370 and 27M (4) from PARKING BRAKE indicator (5).
19. Disconnect circuit 27P lead (6) from panel wiring harness.
20. Remove special purpose cable.

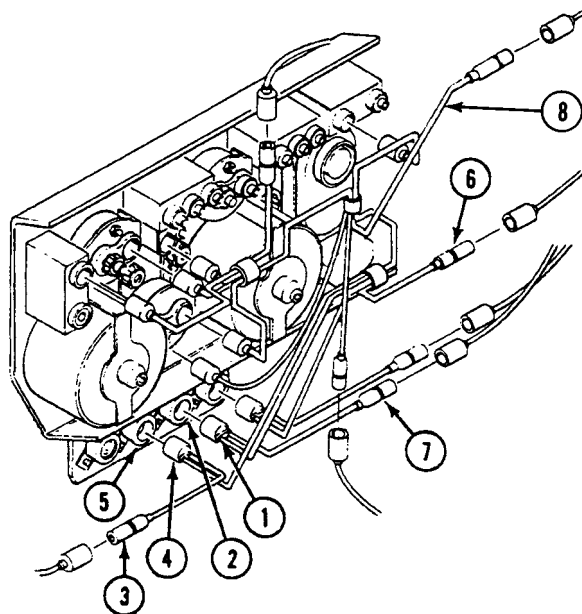

INSTALLATION

1. Install special purpose cable (8).
2. Connect circuit 27P lead (6) to instrument panel wiring harness.
3. Connect circuit 370 lead (3) to panel wiring harness.
4. Connect circuit 370 and 27M leads (4) to PARKING BRAKE indicator (5).
5. Connect circuit 367 lead (7) to panel wiring harness.
6. Connect circuit 367 and 27L leads (1) to TRANS OIL LOW PRESS indicator (2).

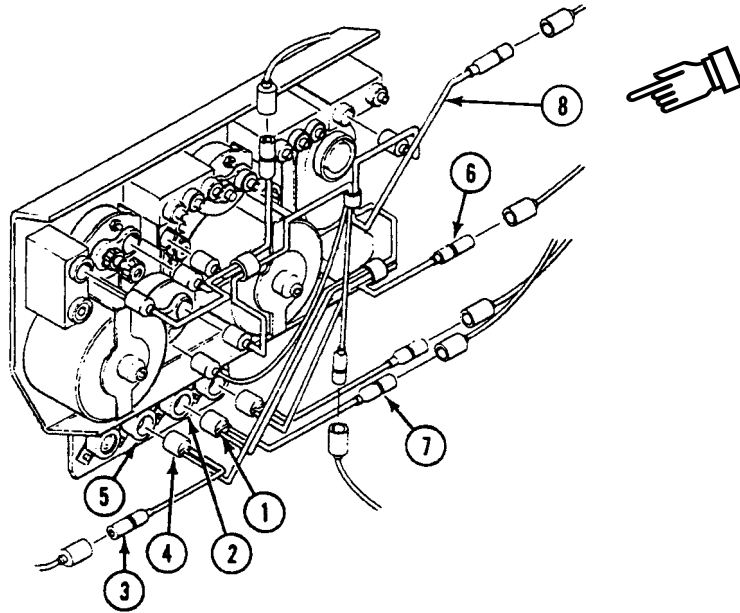

REPLACE INSTRUMENT PANEL SPECIAL PURPOSE CABLE — Continued

0290 00

7. Connect circuit 323 lead (8) to panel wiring harness.
8. Connect circuit 323 and 27R leads (9) to TRANS FILTER CLOGGED indicator (10).
9. Connect circuit 516 lead (11) to IR POWER or DTV (M58 only) switch (12).
10. Connect circuit 459 lead (13) to MASTER SWITCH ON indicator light (14).

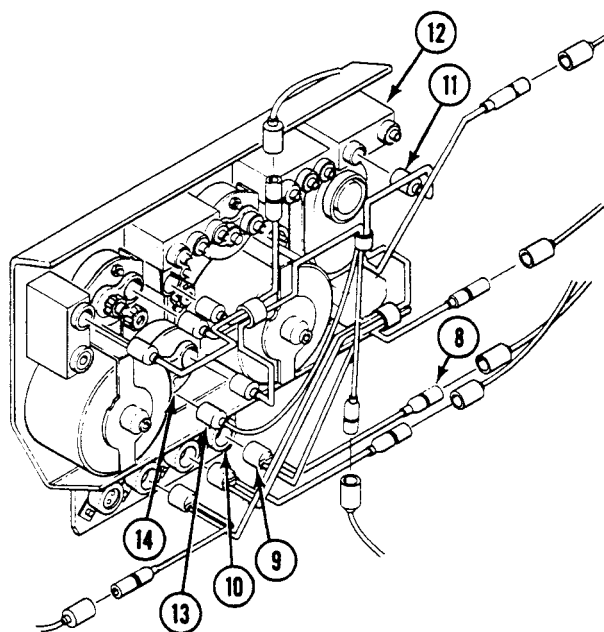

11. Connect circuit 27 lead (1) to instrument panel circuit breaker (2).
12. Connect circuit 27A lead (3) to fuel quantity gage (4).
13. Connect circuit 27B lead (5) to engine coolant temperature gage (6).
14. Connect circuit 27C lead (7) to AIR BOX HEATER switch (8).
15. Connect circuit 27F lead (9) to panel wiring harness.
16. Connect circuit 25A lead (10) to panel wiring harness.
17. Connect circuit 38 lead (11) to panel wiring harness.

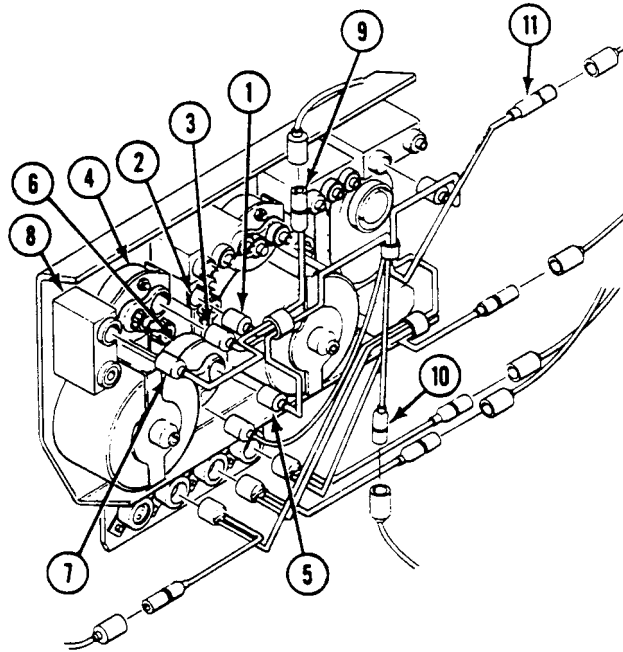

18. Install ground lead (12) and new lockwasher (13) on upper support (14).
19. Install instrument panel (15) with two mounts (16) on support (14). Secure with two screws (17) and washers (18).
20. Install panel (15) on two struts (19). Secure with two nuts (20), mounts (21) and (22), washers (23), and screws (24).

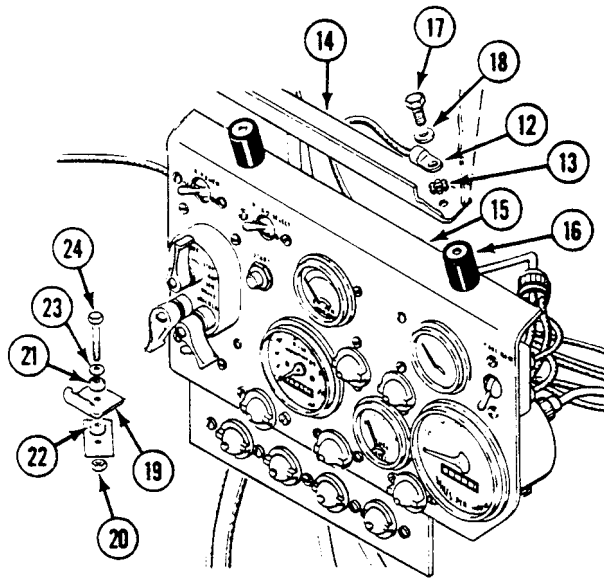

FOLLOW-THROUGH STEPS

1. Connect cables to speedometer and tachometer (WP 0859 00) and (WP 0862 00).
2. Connect battery ground strap (WP 0337 00), (WP 0338 00), or (WP 0339 00).
3. Turn MASTER SWITCH to ON (see your -10).
4. Check gages and insure lights work (see your -10).
5. Turn MASTER SWITCH to OFF (see your -10).

END OF TASK

REPLACE WARNING LIGHT PANEL ASSEMBLY (ALL EXCEPT M58)

0291 00 ■

THIS WORK PACKAGE COVERS:

Removal (page 0291 00-1).
 Installation (page 0291 00-2).

INITIAL SETUP:

Maintenance Level

Unit

References

TM 9-2350-277-10

Tools and Special Tools

General Mechanic's Tool Kit (WP 0926 00, Item 65)

Equipment Condition

Engine stopped (see your -10)

Materials/Parts

Cotter pin (2)

Carrier blocked (see your -10)

Personnel Required

Unit Mechanic

M17 periscope removed (see your -10)

REMOVAL

1. Disconnect five connectors (1) from rear of warning light panel (2).
2. Remove two cotter pins (3), straight pins (4), washers (5), and panel (2) with mount bracket (6) from hull mounts (7). Discard cotter pins.

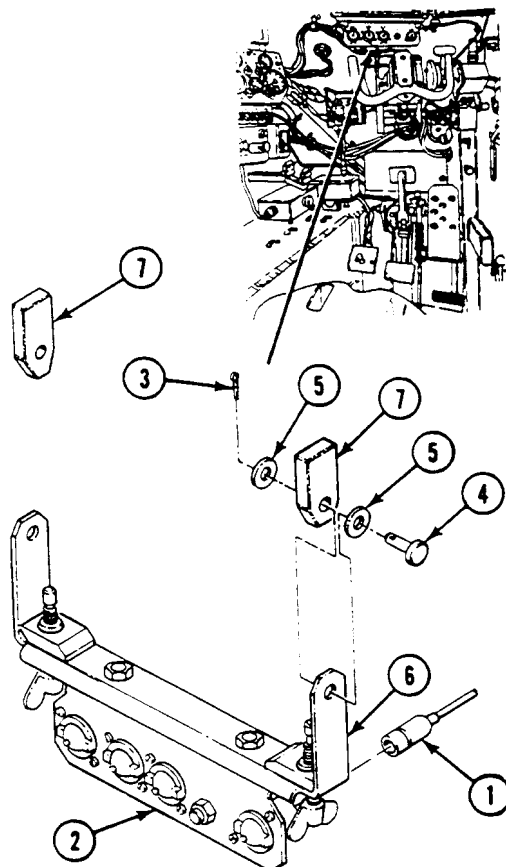

INSTALLATION

1. Position mount bracket (6) on hull mounts (7). Secure with two straight pins (4), washers (5), and new cotter pins (3).

NOTE

Be sure to connect leads to their proper indicators. See wiring diagrams at the end (Vol 6).

2. Connect five connectors (1) on rear of panel (2).

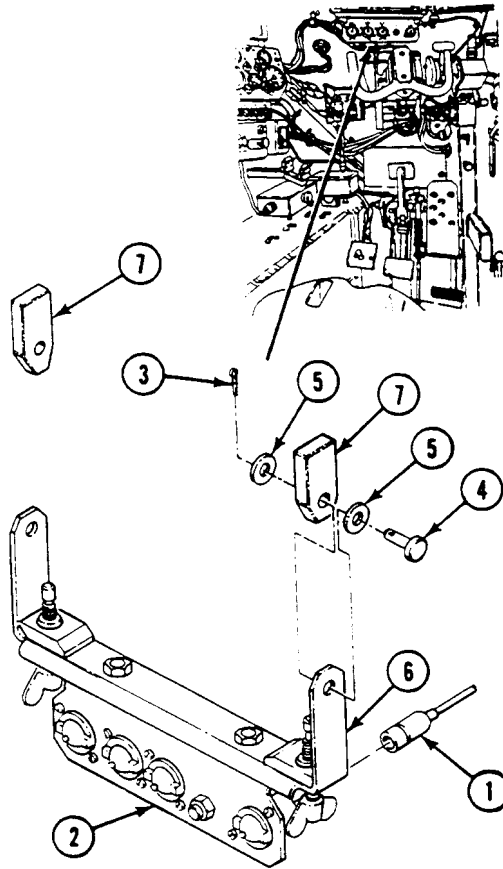
**FOLLOW-THROUGH STEPS**

1. Install M17 periscope (see your -10).

END OF TASK

REPLACE WARNING LIGHT PANEL (ALL EXCEPT M58)

0292 00 ■

THIS WORK PACKAGE COVERS:

Removal (page 0292 00-1).
 Installation (page 0292 00-2).

INITIAL SETUP:

Maintenance Level

Unit

References

TM 9-2350-277-10

Tools and Special Tools

General Mechanic's Tool Kit (WP 0926 00, Item 65)

Equipment Condition

Engine stopped (see your -10)
 Carrier blocked (see your -10)
 M17 periscope removed (see your -10)
 Panel warning lights removed (WP 0294 00)
 Horn switch removed (WP 0293 00)

Materials/Parts

Locknut (2)

Personnel Required

Unit Mechanic

REMOVAL

1. Remove two locknuts (1), screws (2), washers (3), and four mounts (4), from panel (5) and bracket (6). Remove panel from bracket. Discard locknuts.

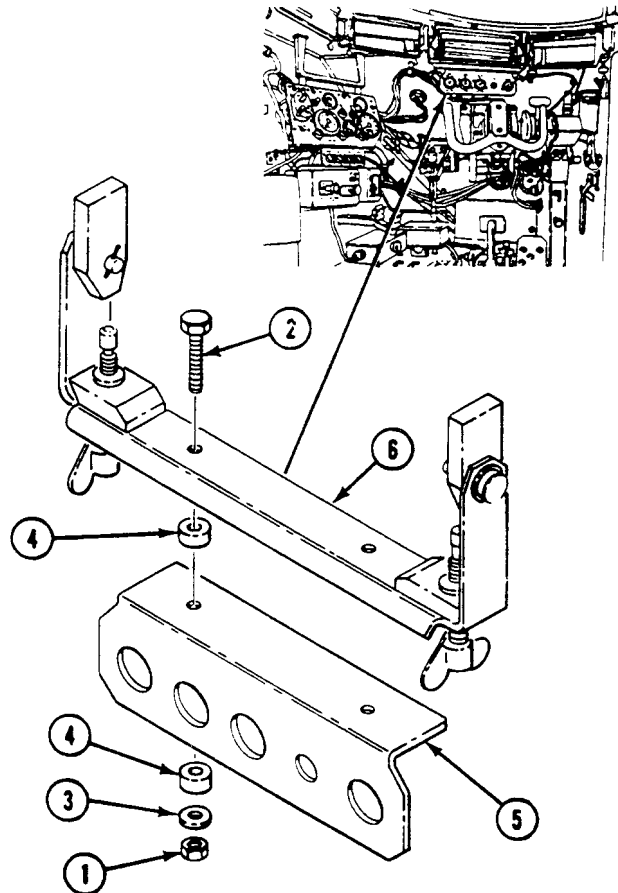

INSTALLATION

1. Install panel (5) on bracket (6). Secure with two screws (2), washers (3), four mounts (4), and new locknuts (1).

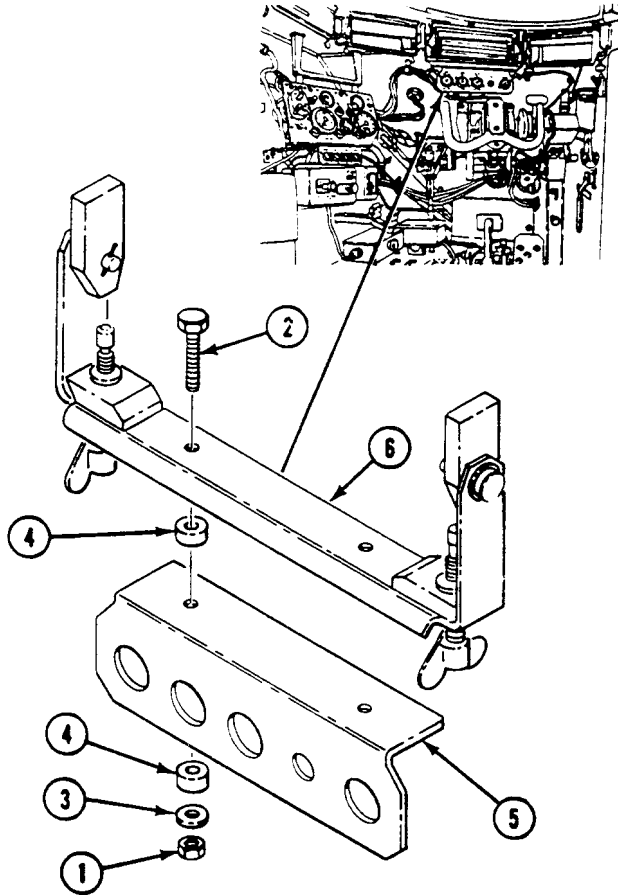
**FOLLOW-THROUGH STEPS**

1. Install horn switch (WP 0293 00).
2. Install panel warning lights (WP 0294 00).
3. Install M17 periscope (see your -10).

END OF TASK

REPLACE HORN SWITCH (ALL EXCEPT M58)

0293 00 ■

THIS WORK PACKAGE COVERS:

Removal (page 0293 00-1).
 Installation (page 0293 00-2).

INITIAL SETUP:

Maintenance Level

Unit

References

See your -10

Tools and Special Tools

General Mechanic's Tool Kit (WP 0926 00, Item 65)

Equipment Condition

Engine stopped (see your -10)
 Carrier blocked (see your -10)
 Battery ground strap disconnected (WP 0337 00),
 (WP 0338 00), or (WP 0339 00)

Personnel Required

Unit Mechanic

REMOVAL

NOTE

Two nuts and lockwashers come with new switch.

1. Disconnect circuit 25/25A connector (1) from rear of HORN switch (2).
2. Remove nut (3) and HORN switch (2) from warning light panel.
3. Remove lockwasher (4) and nut (5) from HORN switch (2).

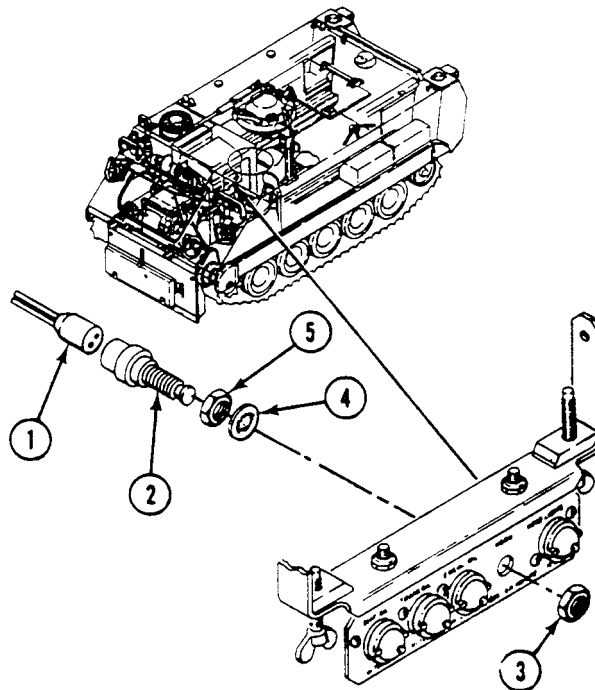

INSTALLATION

1. Install nut (5) and lockwasher (4) on HORN switch (2).
2. Install HORN switch through rear of warning light panel. Secure with nut (3).
3. Connect circuit 25/25A connector (1) to rear of HORN switch (2).

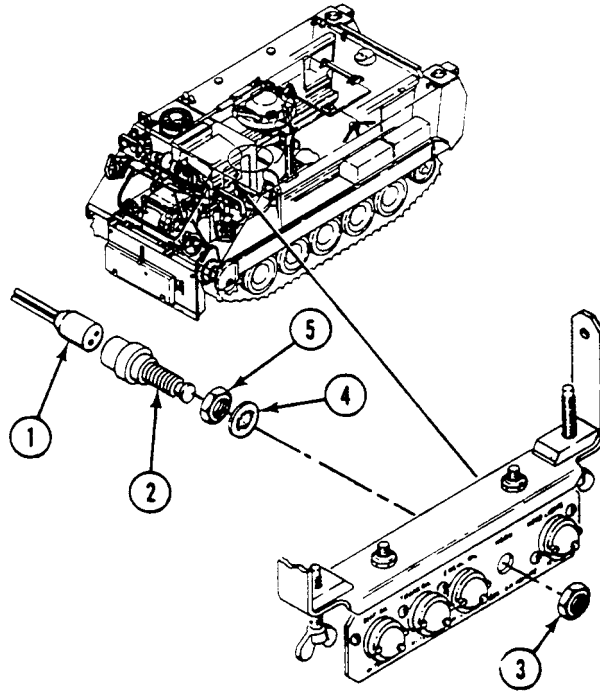
**FOLLOW-THROUGH STEPS**

1. Connect battery ground strap (WP 0337 00), (WP 0338 00), or (WP 0339 00).
2. Turn MASTER SWITCH to ON (see your -10).
3. Press HORN switch to check for proper operation (see your -10).
4. Turn MASTER SWITCH to OFF (see your -10).

END OF TASK

REPLACE HORN SWITCH (M58 ONLY)

0293 01

THIS WORK PACKAGE COVERS:

Removal (page 0293 01-1).
 Installation (page 0293 01-3).

INITIAL SETUP:

Maintenance Level

Unit

References

See your -10

Tools and Special Tools

General Mechanic's Tool Kit (WP 0926 00, Item 65)

Equipment Condition

Engine stopped (see your -10)
 Carrier blocked (see your -10)
 Battery ground strap disconnected (WP 0337 00),
 (WP 0338 00), or (WP 0339 00)

Personnel Required

Unit Mechanic

REMOVAL

NOTE

Two nuts and lockwashers come with new switch.

1. Disconnect circuit 25/25A connector (1) from rear of HORN switch (2).

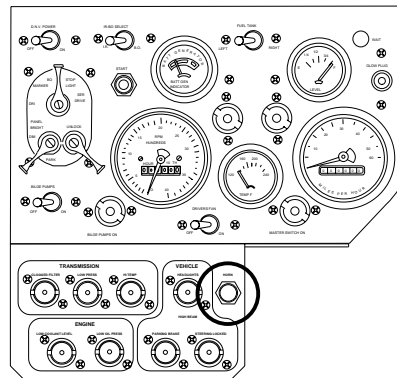
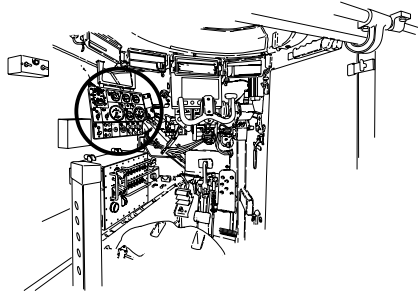

M58 ONLY

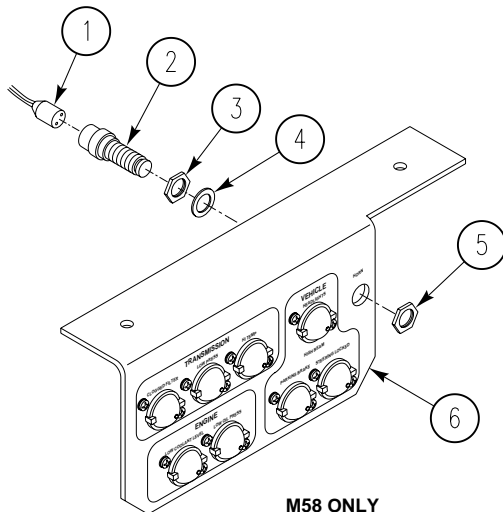

M58 ONLY

REPLACE HORN SWITCH (M58 ONLY) — Continued

0293 01

2. Remove nut (5) and HORN switch (2) from warning light panel (6).
3. Remove lockwasher (4) and nut (3) from HORN switch (2).

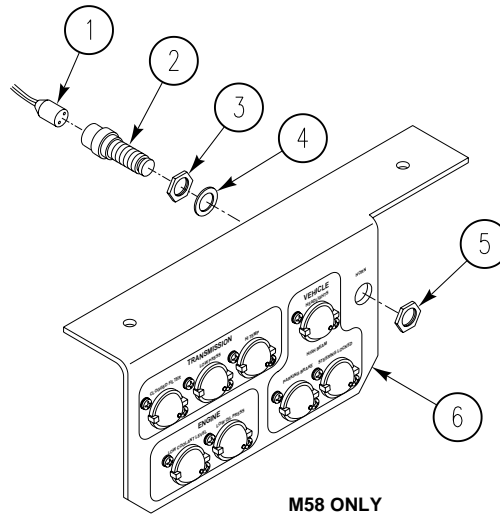
**INSTALLATION**

1. Install nut (3) and lockwasher (4) on HORN switch (2).
2. Install HORN switch (2) through rear of warning light panel (6). Secure with nut (5).
3. Connect circuit 25/25A connector (1) to rear of HORN switch (2).

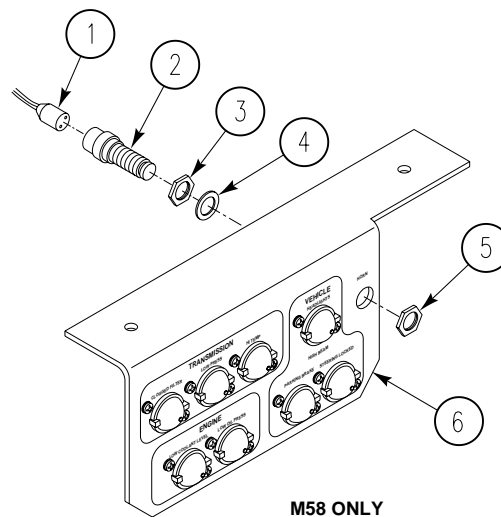
**FOLLOW-THROUGH STEPS**

1. Connect battery ground strap (WP 0337 00), (WP 0338 00), or (WP 0339 00).
2. Turn MASTER SWITCH to ON (see your -10).
3. Press HORN switch to check for proper operation (see your -10).
4. Turn MASTER SWITCH to OFF (see your -10).

END OF TASK

REPLACE WARNING PANEL LIGHTS (ALL EXCEPT M58)

0294 00 ■

THIS WORK PACKAGE COVERS:

- Removal (page 0294 00-1).
 - Installation (page 0294 00-3).
-

INITIAL SETUP:

Maintenance Level

Unit

References

See your -10

Tools and Special Tools

General Mechanic's Tool Kit (WP 0926 00, Item 65)

Equipment Condition

Engine stopped (see your -10)

Carrier blocked (see your -10)

Materials/Parts

Light bulbs (as needed)

Lockwasher (2)

Battery ground strap disconnected (WP 0337 00),
(WP 0338 00), or (WP 0339 00)

Personnel Required

Unit Mechanic

REMOVAL

NOTE

There are four lights on warning panel. All lights are replaced the same way.

1. Remove light bulb (1).
 - a. Turn lens (2) to the left. Remove lens and gasket (3) from light assembly (4).
 - b. Push in and turn light bulb (1) to the left and remove bulb from light assembly (4). Remove gasket (5).

NOTE

Do not disconnect more than one light at a time. Mark each lead to make sure you reconnect to correct contacts. See wiring diagrams at the end of this manual.

2. If required, remove light assembly (4).

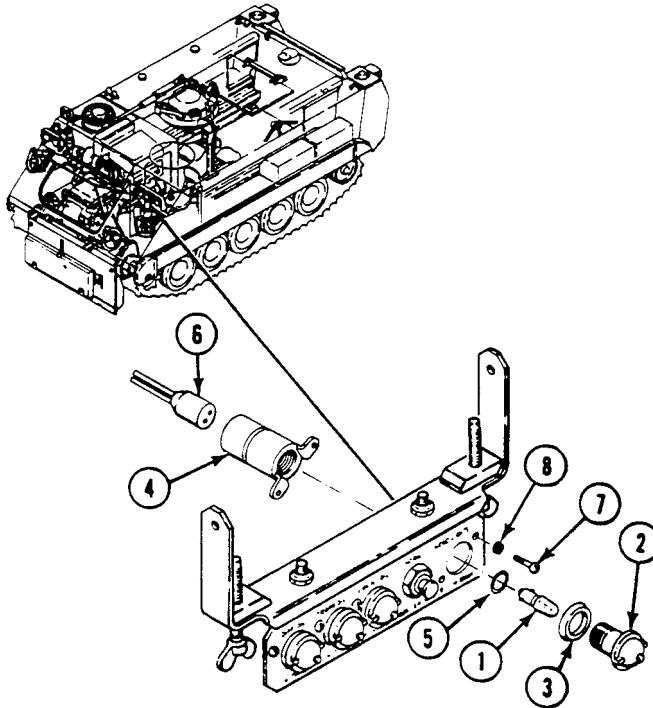

- a. Disconnect circuit lead (6) from light assembly (4).
- b. Remove two screws (7), lockwashers (8), and light assembly (4) from warning lights panel. Discard lockwashers.

INSTALLATION**CAUTION**

Make sure circuit leads are connected to correct lights. See wiring diagrams at the end of this manual.

1. If removed, install light assembly (1).
 - a. Place light assembly (1) on rear of warning light panel. Secure with two new lockwashers (2) and screws (3).
 - b. Connect circuit lead (4) to light assembly (1).
2. Install light bulb (5).

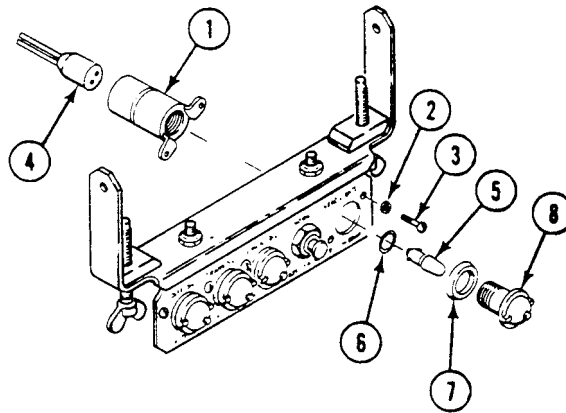

- a. Install gasket (6) and light bulb (5) in light assembly (1). Push and turn light bulb to the right to secure.
- b. Install gasket (7) and lens (8) in light assembly (1). Turn lens to the right to secure.

FOLLOW-THROUGH STEPS

1. Connect battery ground strap (WP 0337 00), (WP 0338 00), or (WP 0339 00).
2. Turn MASTER SWITCH to ON (see your -10).
3. Check warning panel lights as follows (see your -10):
 - a. ENGINE COOLANT LOW LEVEL light should be off. It will come on when you ground circuit 352 lead.
 - b. TRANS OIL HI TEMP indicator should be off. It will come on when you ground circuit lead 327.
 - c. ENGINE OIL LOW PRESS indicator should be on.
 - d. STEERING LOCKED indicator should be on when transmission controller is in SL.
4. Turn MASTER SWITCH to OFF (see your -10).

END OF TASK

REPLACE WARNING PANEL LIGHTS (M58 ONLY)

0294 01

THIS WORK PACKAGE COVERS:

- Removal (page 0294 01-2).
 - Inspection (page 0294 01-2).
 - Installation (page 0294 01-3).
-

INITIAL SETUP:

Maintenance Level

Unit

References

See your -10

Tools and Special Tools

General Mechanic's Tool Kit (WP 0926 00, Item 65)

Equipment Condition

Engine stopped (see your -10)

Carrier blocked (see your -10)

Materials/Parts

Light bulbs (as needed)

Lockwasher (2)

Battery ground strap disconnected (WP 0337 00),
(WP 0338 00), or (WP 0339 00)

Personnel Required

Unit Mechanic

REMOVAL

NOTE

There are eight lights on warning panel. All lights are replaced the same way.

1. Remove light bulb (5).
 - a. Turn lens (9) to the left. Remove lens and gasket (8) from light assembly (2).
 - b. Push in and turn light bulb (5) to the left and remove bulb from light assembly (2). Remove gasket (4).

NOTE

Do not disconnect more than one light at a time. Mark each lead to make sure you reconnect to correct contacts. See wiring diagrams at the end of this manual.

2. If required, remove light assembly (2).Replacement

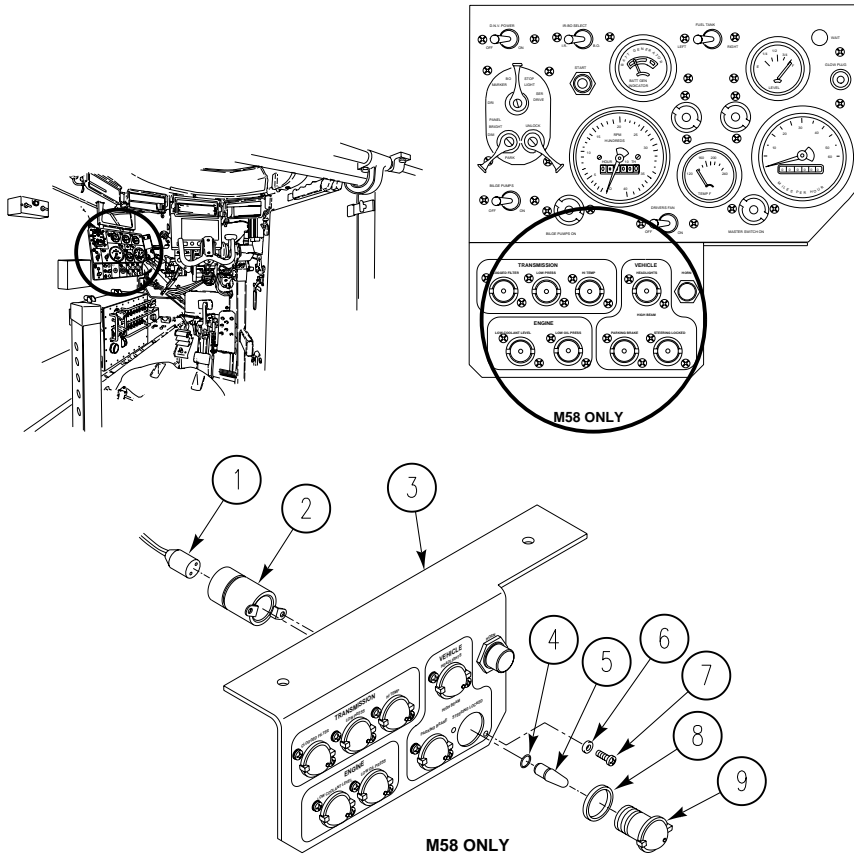

- a. Disconnect circuit lead (1) from light assembly (2).
- b. Remove two screws (7), lockwashers (6), and light assembly (2) from warning lights panel. Discard lockwashers.

INSPECTION-ACCEPTANCE AND REJECTION CRITERIA

1. Check light bulb. See troubleshooting (WP 0038 00). Replace bad light bulb.
Check light assembly. See troubleshooting (WP 0038 00). Replace bad light assembly.

INSTALLATION

CAUTION

Make sure circuit leads are connected to correct lights. See wiring diagrams at the end of this manual.

1. If removed, install light assembly (2).
 - a. Place light assembly (2) on rear of warning light panel. Secure with two new lockwashers (6) and screws (7).
 - b. Connect circuit lead (1) to light assembly (2).
2. Install light bulb (5).
 - a. Install gasket (4) and light bulb (5) in light assembly (2). Push and turn light bulb to the right to secure.
 - b. Install gasket (8) and lens (9) in light assembly (2). Turn lens to the right to secure.

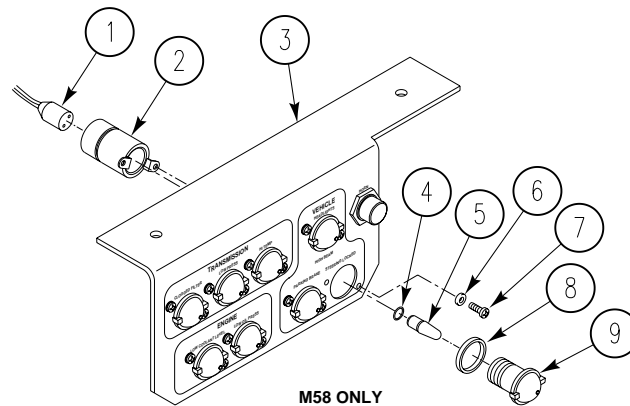
**FOLLOW-THROUGH STEPS**

1. Connect battery ground strap (WP 0337 00), (WP 0338 00), or (WP 0339 00).
2. Turn MASTER SWITCH to ON (see your -10).
3. Check warning panel lights as follows (see your -10):
 - a. ENGINE COOLANT LOW LEVEL light should be off. It will come on when you ground circuit 352 lead.
 - b. TRANS OIL HI TEMP indicator should be off. It will come on when you ground circuit lead 327.
 - c. ENGINE OIL LOW PRESS indicator should be on.
 - d. STEERING LOCKED indicator should be on when transmission controller is in SL.
4. Turn MASTER SWITCH to OFF (see your -10).

END OF TASK

REPLACE INSTRUMENT PANEL MOUNTS AND GROUND LEAD (ALL EXCEPT M58)

0295 00

THIS WORK PACKAGE COVERS:

Removal (page 0295 00-2).
 Installation (page 0295 00-4).

INITIAL SETUP:

Maintenance Level

Unit

References

See your -10

Tools and Special Tools

General Mechanic's Tool Kit (WP 0926 00, Item 65)

Materials/Parts

Lockwasher (5)
 Locknut (2)
 Resilient Mount (2)

Equipment Condition

Engine stopped (see your -10)
 Carrier blocked (see your -10)

Personnel Required

Unit Mechanic

Battery ground strap disconnected (WP 0337 00),
 (WP 0338 00), or (WP 0339 00)

REPLACE INSTRUMENT PANEL MOUNTS AND GROUND LEAD (ALL EXCEPT M58) —
Continued

0295 00

REMOVAL

1. Remove two locknuts (1), mounts (2), resilient mounts (3), flat washers (4), and screws (5) from struts (6) and (7) and instrument panel. Discard locknuts and resilient mounts.
2. Support instrument panel and remove two screws (8), ground lead (9), WAIT indicator ground lead (12) (glow plug system only), and two lockwashers (10) from two resilient mounts (11) and upper support bracket. Discard lockwashers.

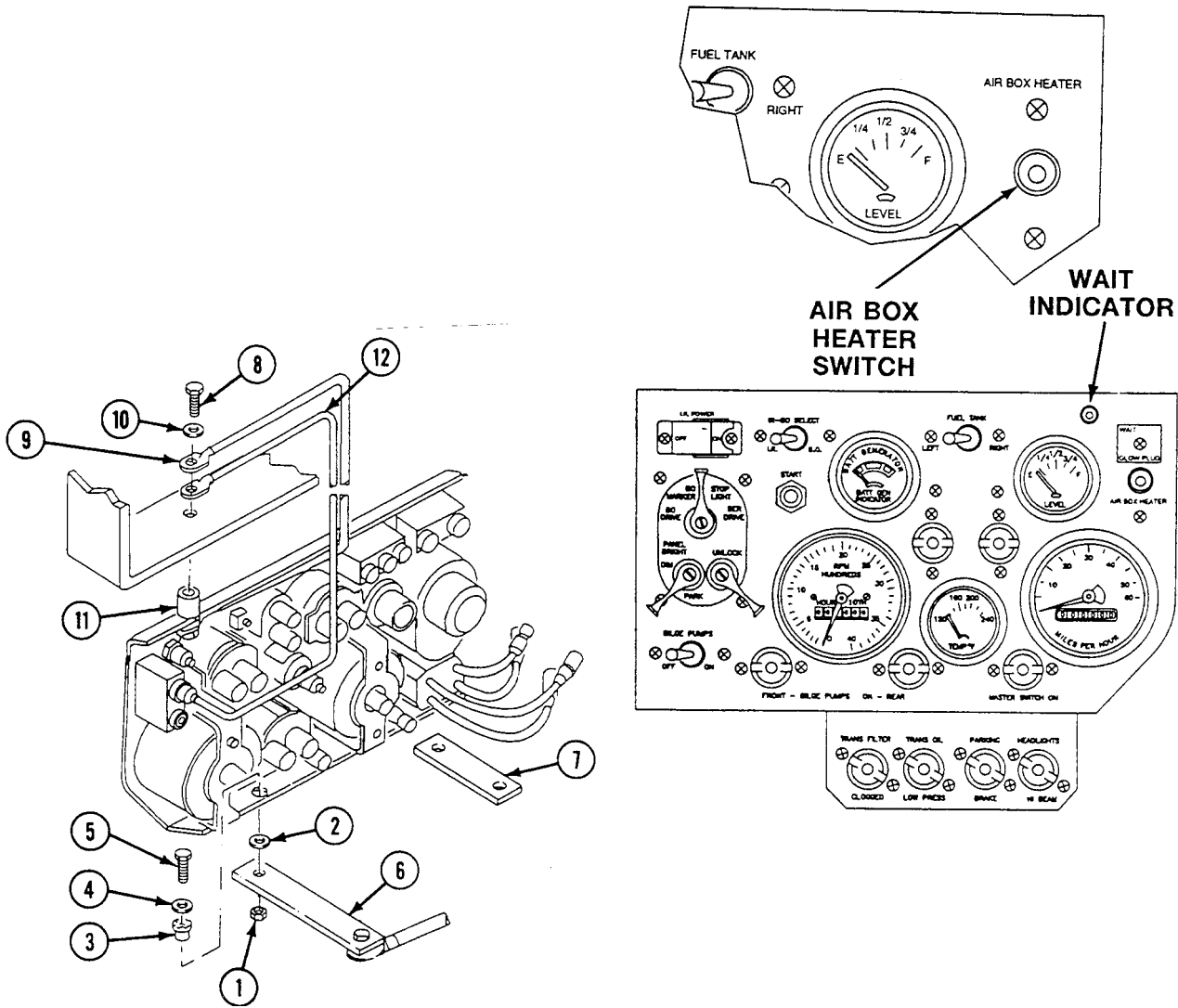

REPLACE INSTRUMENT PANEL MOUNTS AND GROUND LEAD (ALL EXCEPT M58) —
Continued

0295 00

3. Tip instrument panel forward and remove two screws (1), ground lead (2), WAIT indicator ground lead (26) (glow plug system only), two lockwashers (3), and resilient mounts (4) from instrument panel. Discard lockwashers.
4. Remove nut (5), washer (6), lockwasher (7), ground lead (8), ground lead (9), screw (10), washer (11), and long strut (12) from hull mounts. Discard lockwasher.
5. Remove nut (13), washers (14), screw (15), washer (16), and strut (17) from hull mount.

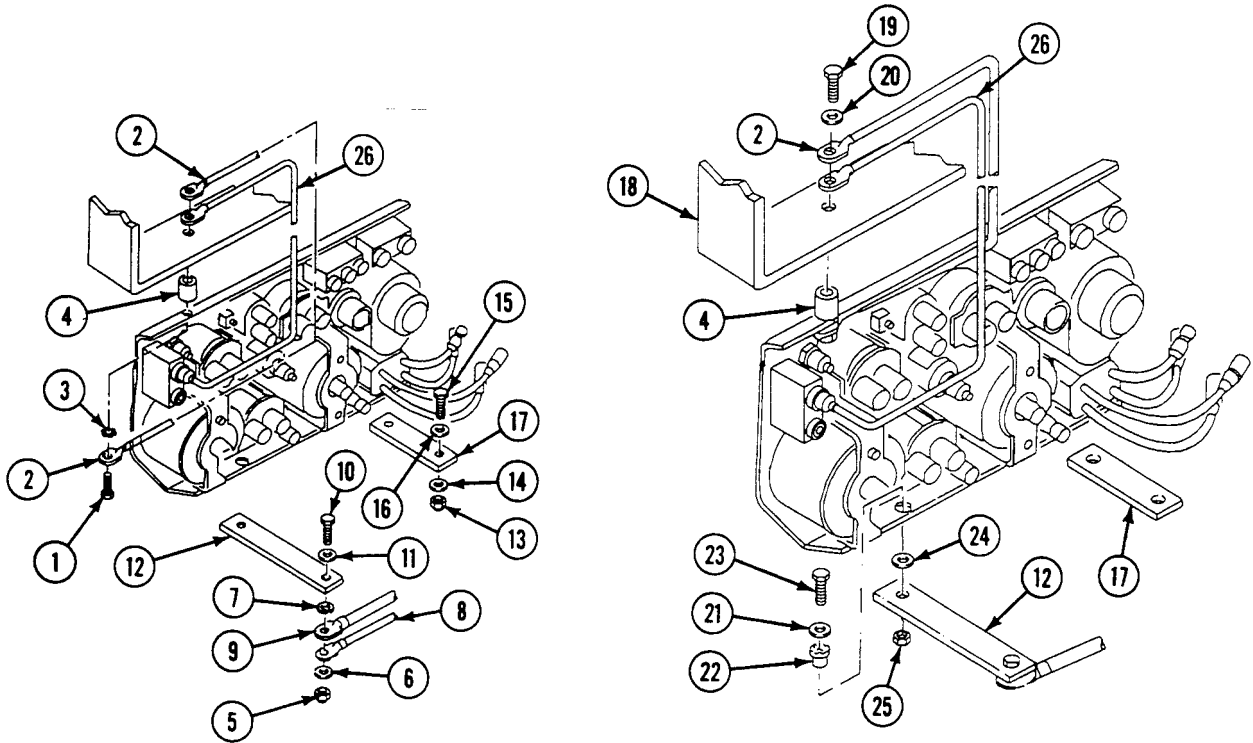

REPLACE INSTRUMENT PANEL MOUNTS AND GROUND LEAD (ALL EXCEPT M58) —**0295 00****Continued****INSTALLATION**

1. Place strut (17) on hull mount. Secure with screw (15), washer (16), washer (14), and nut (13). Do not tighten nut.
2. Place strut (12) on hull mount. Secure with screw (10), washer (11), new lockwasher (7), ground lead (9), ground lead (8), washer (6), and nut (5). Do not tighten nut.
3. Install ground lead (2), WAIT indicator ground lead (26) (glow plug system only), and two new lockwashers (3) on two screws (1). Insert screws thru instrument panel and secure with two resilient mounts (4).
4. Secure ground lead (2), WAIT indicator ground lead (26) (glow plug system only), and resilient mount (4) to upper support bracket (18) with screw (19) and new lockwasher (20).
5. Secure other resilient mount (4) to bracket (18) with screw (19) and new lockwasher (20).
6. Install two washers (21) and new resilient mounts (22) on screws (23), and position through instrument panel. Install two mounts (24) on screws and insert screws through struts (12) and (17). Secure with two new locknuts (25). Tighten nuts (5) and (13).

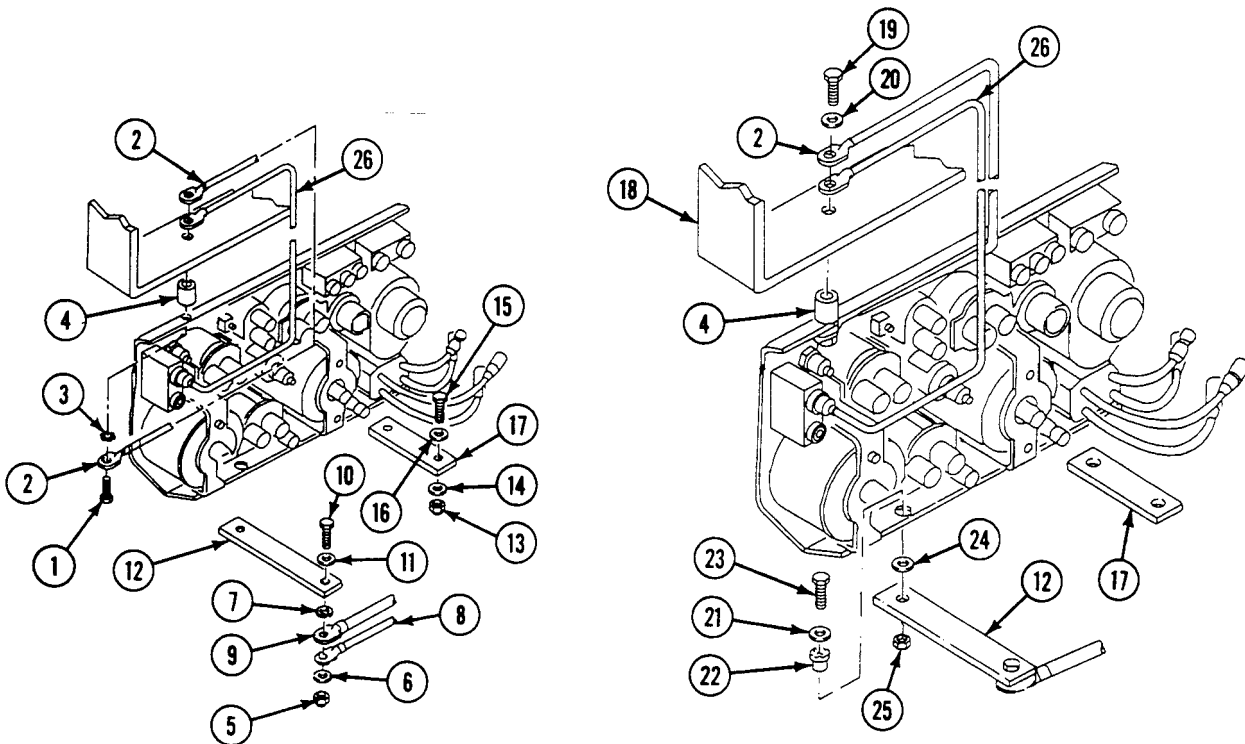
**FOLLOW THROUGH STEPS**

1. Connect battery ground strap (WP 0337 00), (WP 0338 00), or (WP 0339 00).

END OF TASK

REPLACE INSTRUMENT PANEL MOUNTS AND GROUND LEAD (M58 ONLY)

0295 01

THIS WORK PACKAGE COVERS:

Removal (page 0295 01-1).
 Installation (page 0295 01-2).

INITIAL SETUP:

Maintenance Level

Unit

References

See your -10

Tools and Special Tools

General Mechanic's Tool Kit (WP 0926 00, Item 65)

Equipment Condition

Engine stopped (see your -10)
 Carrier blocked (see your -10)
 Battery ground strap disconnected (WP 0337 00),
 (WP 0338 00), or (WP 0339 00)

Materials/Parts

Lockwasher (5)
 Locknut (2)
 Resilient Mount (2)

Personnel Required

Unit Mechanic

REMOVAL

1. Remove two locknuts (1), mounts (2), resilient mounts (3), flat washers (4), and screws (5) from struts (6) and (7) and instrument panel. Discard locknuts and resilient mounts.
2. Support instrument panel and remove two screws (8), ground lead (9), WAIT indicator ground lead (12) (glow plug system only), and two lockwashers (10) from two resilient mounts (11) and upper support bracket.

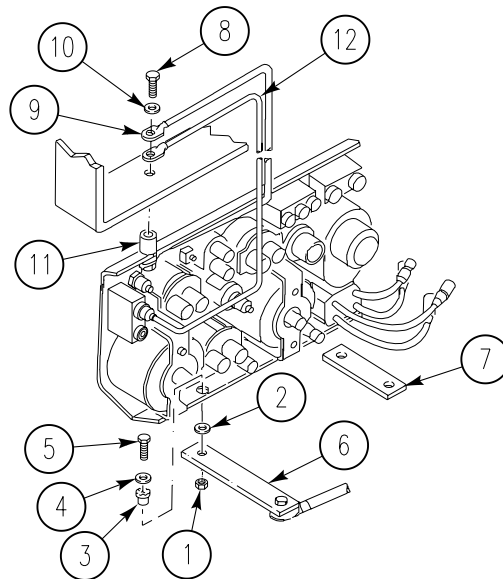

REPLACE INSTRUMENT PANEL MOUNTS AND GROUND LEAD (M58 ONLY) —
Continued

0295 01

3. Tip instrument panel forward and remove two screws (1), ground lead (2), wiring harness ground lead (3), two lockwashers (4), and resilient mounts (5) from instrument panel. Discard lockwashers.
4. Remove nut (16), washer (15), lockwasher (19), ground lead (17), ground lead (18), screw (13), washer (14), and long strut (20) from hull mounts. Discard lockwasher.
5. Remove nut (12), washers (11), screw (8), washer (9), and strut (10) from hull mount.

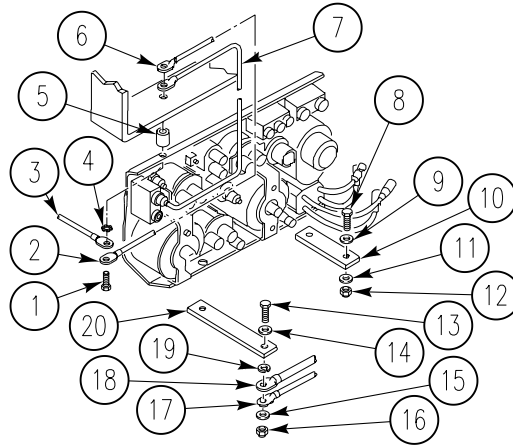

INSTALLATION

1. Place strut (2) on hull mount. Secure with screw (8), washer (9), washer (11), and nut (12). Do not tighten nut.
2. Place strut (20) on hull mount. Secure with screw (13), washer (14), new lockwasher (19), ground lead (18), ground lead (17), washer (15), and nut (16). Do not tighten nut.
3. Install ground lead (6), wiring harness ground lead (3), WAIT indicator ground lead (7) (glow plug system only), and two new lockwashers (4) on two screws (1). Insert screws thru instrument panel and secure with two resilient mounts (5).

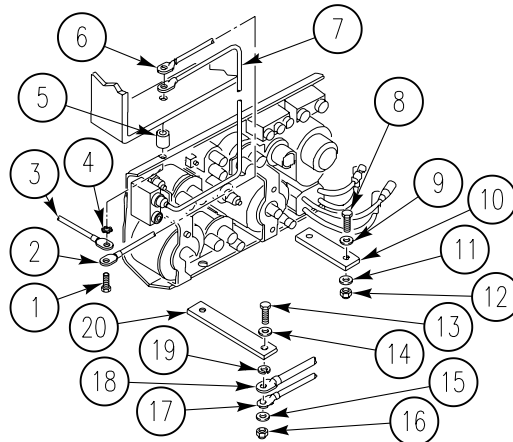

REPLACE INSTRUMENT PANEL MOUNTS AND GROUND LEAD (M58 ONLY) —
Continued

0295 01

4. Secure ground lead (2), WAIT indicator ground lead (26) (glow plug system only), and resilient mount (4) to upper support bracket (18) with screw (19) and new lockwasher (20).
5. Secure other resilient mount (4) to bracket (18) with screw (19) and new lockwasher (20).
6. Install two washers (21) and new resilient mounts (22) on screws (23), and position through instrument panel. Install two mounts (24) on screws and insert screws through struts (12) and (17). Secure with two new locknuts (25). Tighten nuts on struts (12) and (17).

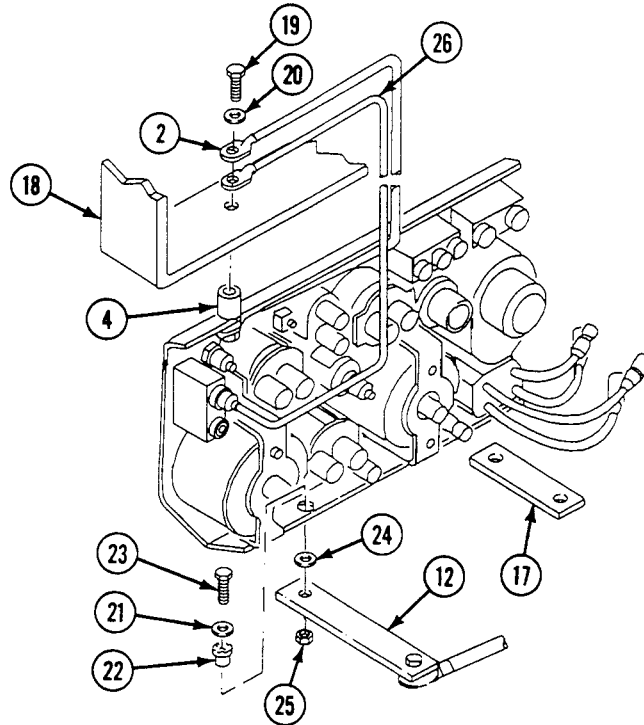
FOLLOW THROUGH STEPS

1. Connect battery ground strap (WP 0337 00), (WP 0338 00), or (WP 0339 00).

END OF TASK

REPLACE TELEPOSTS AND COVER

0296 00

THIS WORK PACKAGE COVERS:

Removal (page 0296 00-1).
 Installation (page 0296 00-3).

INITIAL SETUP:

Maintenance Level

Unit

References

See your -10

Tools and Special Tools

General Mechanic's Tool Kit (WP 0926 00, Item 65)

Equipment Condition

Engine stopped (see your -10)

Materials/Parts

Gasket (8)

Carrier blocked (see your -10)

Personnel Required

Unit Mechanic

Ramp lowered (see your -10)

REMOVAL

NOTE

All carriers are equipped with teleposts. On the M113A3 and M1064A3, the teleposts are located on the right ceiling plate in front of the fuel tank. On the M1059A3 and M58, they are located on the left ceiling plate in front of the fuel tank. On the M577A3 and M1068A3, they are located on the right rear plate next to the ramp. The replacement procedure is the same at all locations.

REPLACE TELEPOSTS AND COVER — Continued

0296 00

1. Remove two screws (1), retainer strip (2), and rubber shield (3) from hull mount.
2. Remove eight teleposts (4), washers (5), and gaskets (6) from four posts (7). Discard gaskets.
3. Remove four posts (7) and insulators (8) from hull.

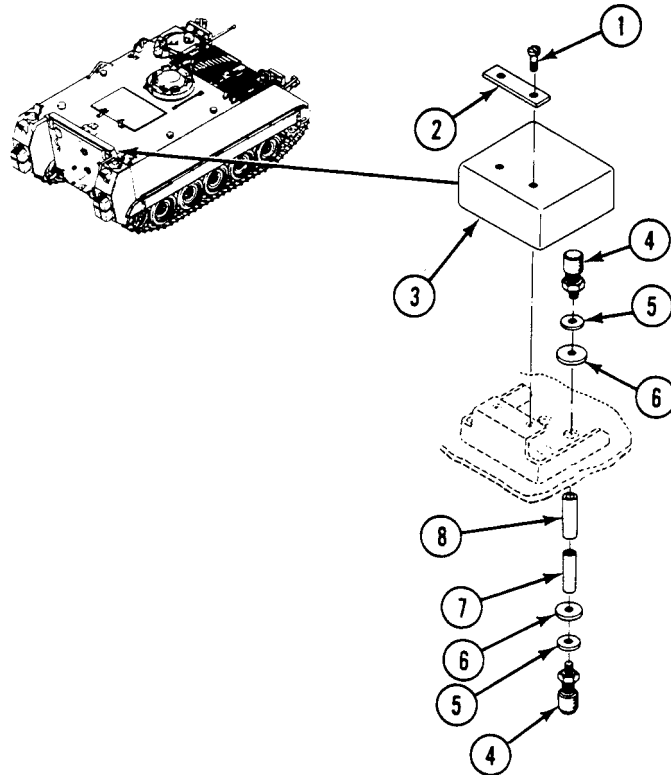

INSTALLATION

1. Install four insulators (8) and posts (7) in hull.
2. Install eight new gaskets (6), washers (5), and teleposts (4) on each end of four posts (7).
3. Install rubber shield (3) on hull mount. Secure with retainer strip (2) and two screws (1).

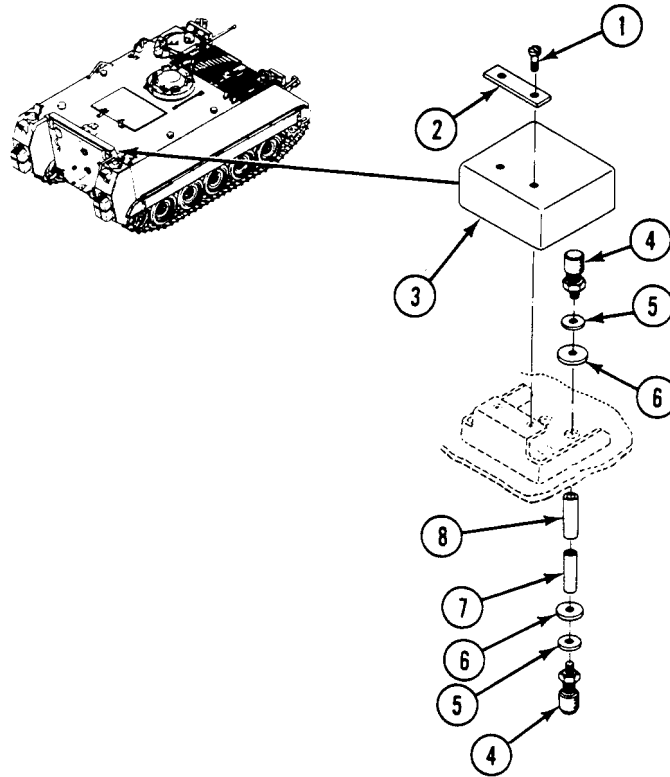
**FOLLOW-THROUGH STEPS**

1. Start engine (see your -10).
2. Raise and lock ramp (see your -10).
3. Stop engine (see your -10).

END OF TASK

REPLACE SOLID STATE INFRARED POWER SUPPLY

0297 00

THIS WORK PACKAGE COVERS:

Removal (page 0297 00-1).
 Installation (page 0297 00-3).

INITIAL SETUP:

Maintenance Level

Unit

References

See your -10

Tools and Special Tools

General Mechanic's Tool Kit (WP 0926 00, Item 65)

Equipment Condition

Engine stopped (see your -10)

Carrier blocked (see your -10)

Materials/Parts

Lockwasher (8)

Personnel Required

Unit Mechanic

Battery ground strap disconnected (WP 0337 00),
 (WP 0338 00), or (WP 0339 00)

REMOVAL

WARNING



High voltage in the M19 periscope can cause serious injury or death. To avoid accidents:

ALWAYS connect power cable to M19 periscope BEFORE turning MASTER SWITCH and IR POWER switch ON.

After turning IR POWER and MASTER switches OFF, ALWAYS wait at least 2 minutes BEFORE disconnecting power cable from M19 periscope.

NEVER touch the end of the cable. Voltage could exceed 16,000 volts.

REPLACE SOLID STATE INFRARED POWER SUPPLY — Continued

0297 00

1. Disconnect circuit 516A lead (1) and circuit 517 lead (2) from power supply (3).
2. Remove four screws (4), eight lockwashers (5), and power supply (3). Discard lockwashers.
3. Check connectors (1). If connectors have bent or missing contact pins, notify supervisor.

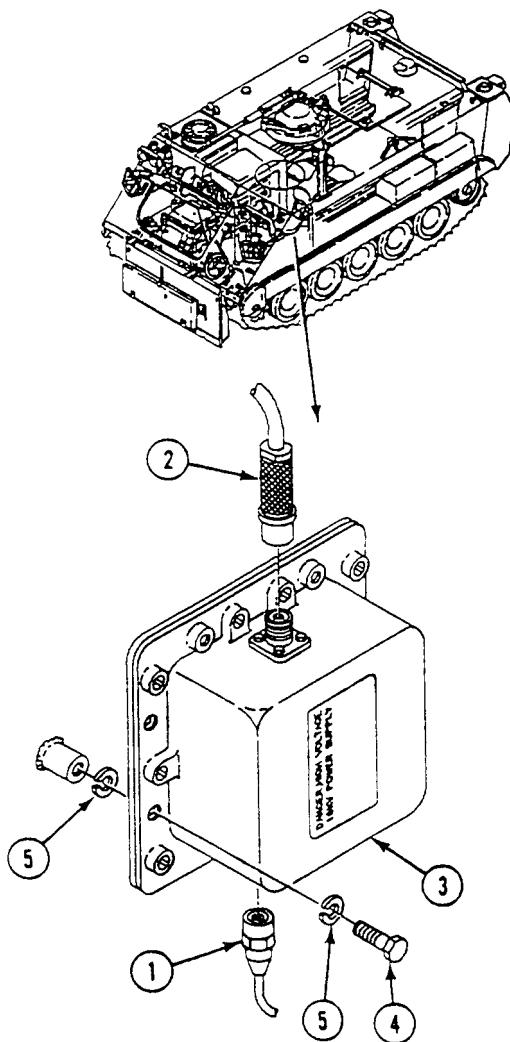

INSTALLATION

1. Install power supply (2) on four weldnuts. Secure with four screws (3) and eight new lockwashers (4).
2. Connect circuit 517 lead (5) and circuit 516A lead (6) to power supply (2).

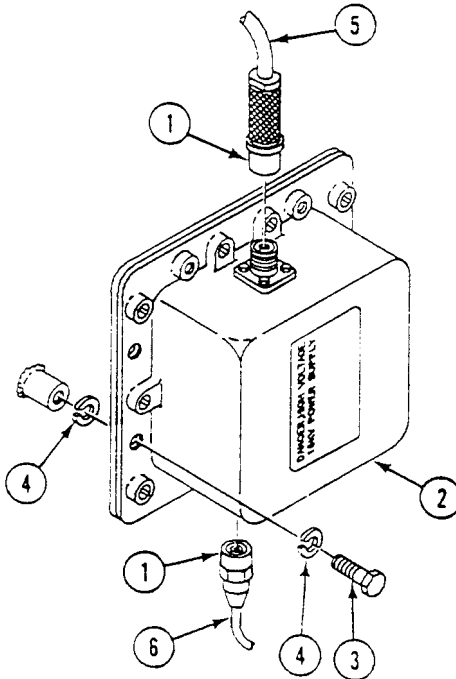
**FOLLOW-THROUGH STEPS**

1. Connect battery ground strap (WP 0337 00), (WP 0338 00), or (WP 0339 00).
2. Turn MASTER SWITCH to ON (see your -10).
3. Install and operate DNV to check that infrared power supply is operable (see your -10).
4. Turn all infrared periscope switches off (see your -10).
5. Turn MASTER SWITCH to OFF (see your -10).
6. Stow periscope (see your -10).

END OF TASK

REPLACE STOP LIGHT-TAIL LIGHT AND GUARDS (ALL EXCEPT M577A3 AND M1068A3)

0298 00

THIS WORK PACKAGE COVERS:

Removal (page 0298 00-1).
 Installation (page 0298 00-4).

INITIAL SETUP:

Maintenance Level

Unit

References

See your -10

Tools and Special Tools

General Mechanic's Tool Kit (WP 0926 00, Item 65)

Equipment Condition

Engine stopped (see your -10)

Carrier blocked (see your -10)

Materials/Parts

Gasket

Lockwasher (6)

Battery ground strap disconnected

(WP 0337 00)

Personnel Required

Unit Mechanic

REMOVAL

NOTE

Except for number of circuit leads, left and right stop light-tail light and guards are replaced the same way. Tag leads so you will know how to install them.

1. On left stop light-tail light, disconnect circuit 21 lead (1), circuit 22 lead (2), and circuit 24 lead (3) from stop light-tail light (4).
2. On right stop light-tail light, disconnect circuit 24 lead (5) and circuit 23 lead (6) from stop light-tail light (7).

NOTE

To remove antenna support on the M58 only (WP 0602 00). The M58 has only a left antenna support.

Cable reel holder is only used on the right tank on the M1064A3 and M58.

3. Remove two screws (8), lockwashers (9), washers (10), and cable reel holder (11) (M1064A3 and M58 only) from guard (12) and external fuel tank. Discard lockwashers.

REPLACE STOP LIGHT-TAIL LIGHT AND GUARDS (ALL EXCEPT M577A3 AND M1068A3) — Continued

0298 00

4. Remove two screws (13), lockwasher (14), washers (15), and guard (12) with stop light-tail light (4) or (7) from external fuel tank. Discard lockwashers.

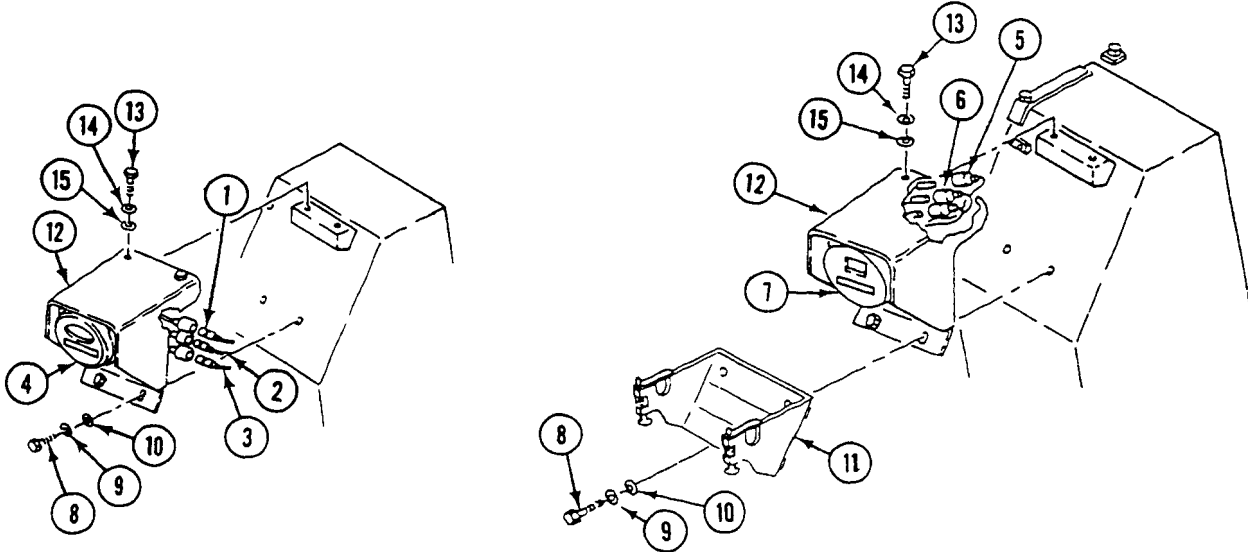

5. Remove two screws (1), lockwashers (2), gasket (3), and stop light-tail light (4) from guard (5). Discard lockwashers and gasket.
6. If needed, remove two screws (6), lockwashers (7), washers (8), and bracket (9) from fuel tank.

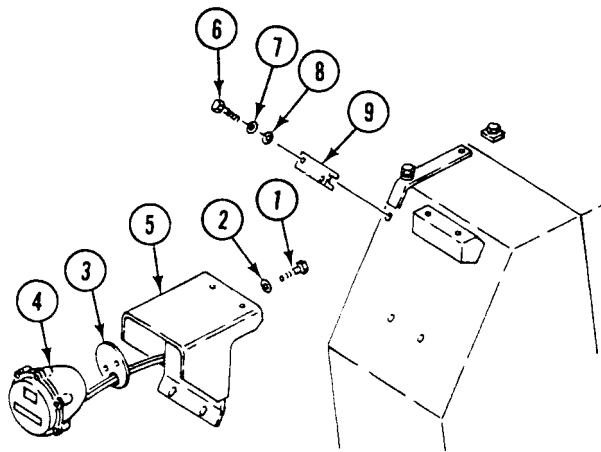

NOTE

Fuel line guard is used on the M1059A3 only.

NOTE

Step 7 is for the right fuel tank. Use same procedures for left fuel tank guards, if required, for M113A3 and M1064A3

7. If needed, remove two screws (10), lockwashers (11), and washers (12), that secure harness bracket (13) and fuel line guard (14) (M1059A3 only), to top of fuel tank. Remove harness bracket and fuel line guard. Discard lockwashers.
8. If needed, remove screw (15), lockwasher (16), washer (17), and guard (18) from carrier top deck.

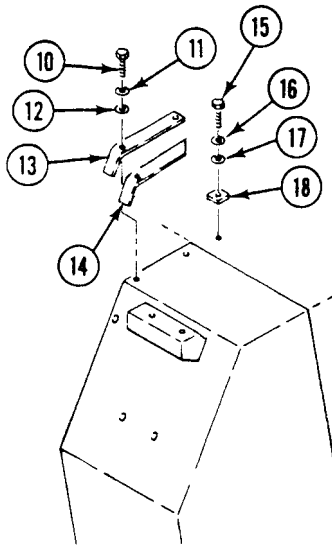

REPLACE STOP LIGHT-TAIL LIGHT AND GUARDS (ALL EXCEPT M577A3 AND M1068A3) — Continued

0298 00

INSTALLATION**NOTE**

■ To install antenna support on the M58, see (WP 0602 00). The M58 has only a left antenna support.

1. If removed, place guard (18) on top deck. Secure with screw (15), new lockwasher (16), and washer (17).

NOTE

Fuel line guard is used on the M1059A3 only.

NOTE

■ Step 2 is for the right fuel tank. Use same procedures for left fuel tank guards, if required, for M113A3 and M1064A3.

2. If removed, replace harness bracket (13) on top of fuel tank. Install fuel line guard (14) (M1059A3 only) over fuel lines and align holes of guard and bracket. Secure with two screws (10), new lockwashers (11), and washers (12).

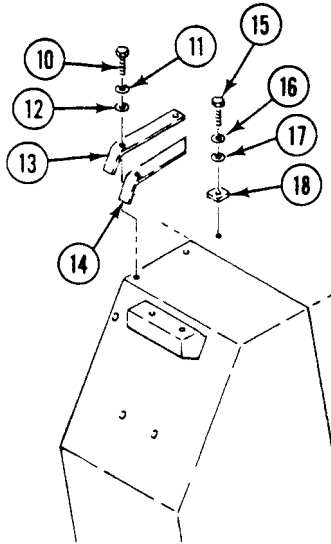

REPLACE STOP LIGHT-TAIL LIGHT AND GUARDS (ALL EXCEPT M577A3 AND M1068A3) — Continued

0298 00

3. If removed, install bracket (9) on fuel tank. Secure with two screws (6), new lockwashers (7), and washers (8).
4. Place new gasket (3) and stop light-tail light (4) on guard (5). Secure with two screws (1) and two new lockwashers (2).

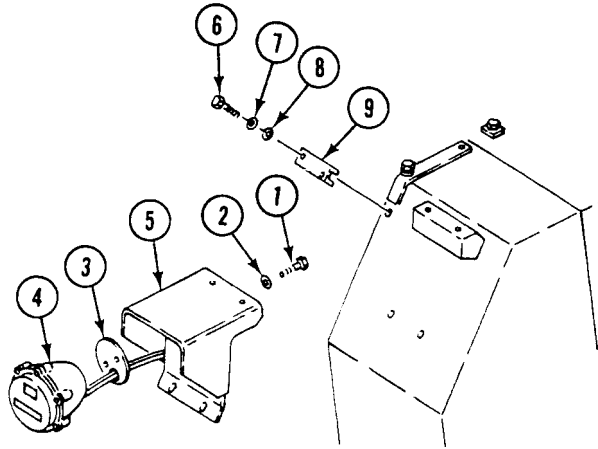

5. Place guard (1) with stop light-tail light (2) on fuel tank. Secure with two screws (3), new lockwashers (4), and washers (5).

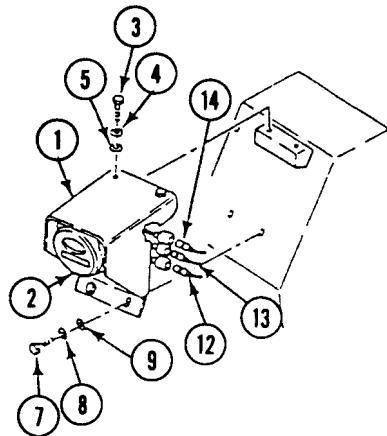

REPLACE STOP LIGHT-TAIL LIGHT AND GUARDS (ALL EXCEPT M577A3 AND M1068A3) — Continued

0298 00

NOTE

■ Cable reel holder is only used on the right tank on the M1064A3 and M58.

- 6. Place cable reel holder (6) (M1064A3 and M58 only) on bottom of guard. Secure with two screws (7), new lockwashers (8), and washers (9).
- 7. On right stop light-tail light, connect circuit 23 lead (10) and circuit 24 lead (11) to stop light-tail light (2).
- 8. On left stop light-tail light, connect circuit 24 lead (12), circuit 22 lead (13), and circuit 21 lead (14) to stop light-tail light (2).

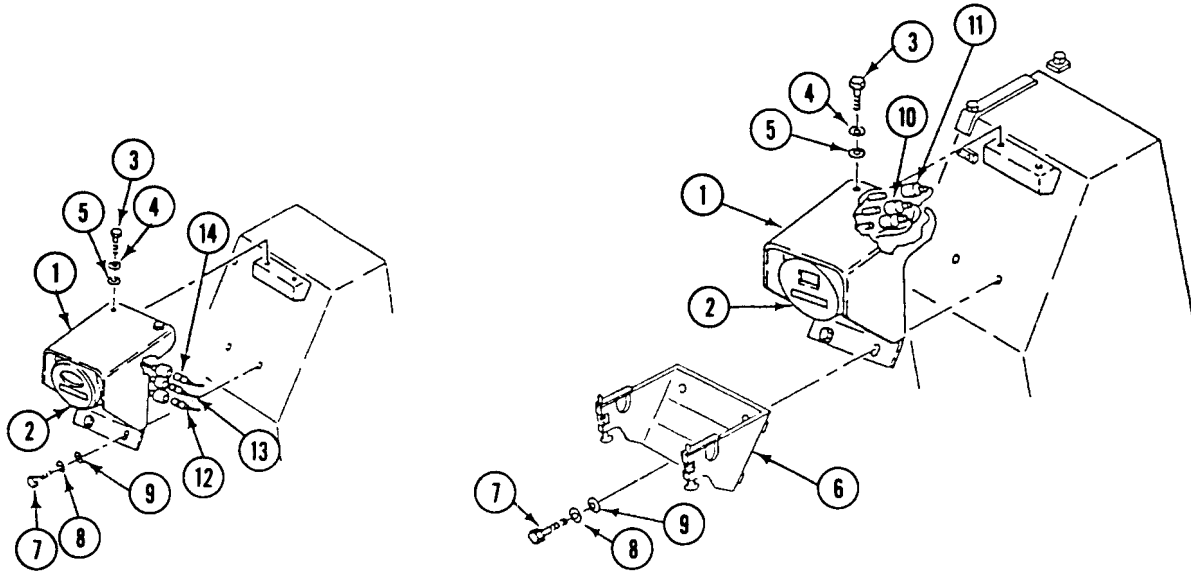

FOLLOW-THROUGH STEPS

- 1. Connect battery ground strap (WP 0337 00).
- 2. Turn MASTER SWITCH ON (see your -10).
- 3. Operate main light switches to check that left and right stop light-tail lights work properly (see your -10).
- 4. Turn all switches OFF (see your -10).

END OF TASK

REPLACE LEFT STOP LIGHT-TAIL LIGHT (M577A3 AND M1068A3 ONLY)

0299 00

THIS WORK PACKAGE COVERS:

Removal (page 0299 00-1).
 Installation (page 0299 00-2).

INITIAL SETUP:

Maintenance Level
 Unit

References
 See your -10

Tools and Special Tools
 General Mechanic's Tool Kit (WP 0926 00, Item 65)

Equipment Condition

Materials/Parts
 Gasket
 Lockwasher (2)
Personnel Required
 Unit Mechanic

Engine stopped (see your -10)
 Carrier blocked (see your -10)
 Ramp lowered (see your -10)
 Battery ground lead disconnected (WP 0338 00)

REMOVAL

1. Disconnect circuit 21 lead (1), circuit 22 lead (2), and circuit 24 (3) lead from tail light leads (4).
2. Remove two nuts (5), lockwashers (6), clamp (7), stop light-tail light (8), and gasket (9) from carrier hull. Discard gasket and lockwashers.
3. If needed, remove two studs (10) from rear of stop light-tail light (8).

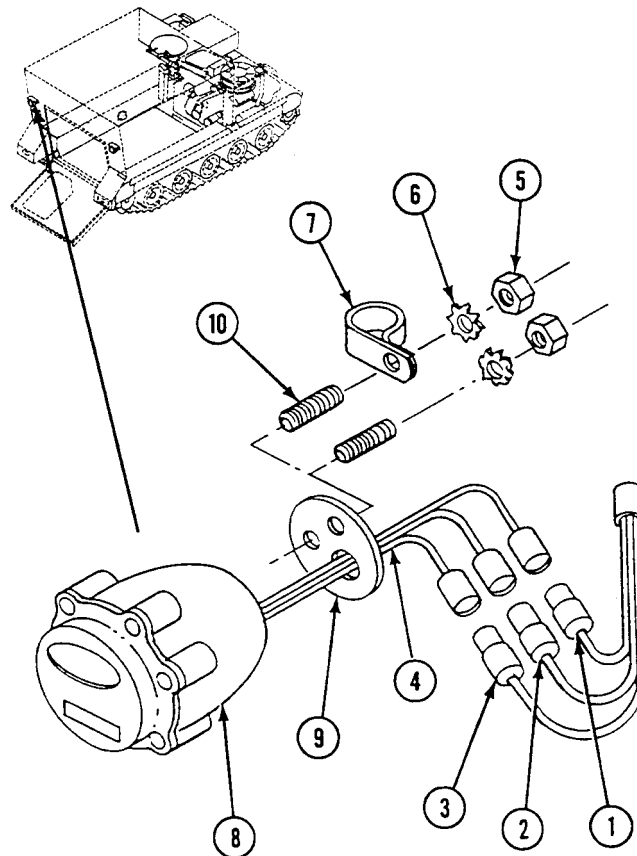

INSTALLATION

1. If removed, install two studs (10) in rear of stop light-tail light (8).
2. Place new gasket (9), stop light-tail light (8), and clamp (7) on carrier hull. Secure with two new lockwashers (6) and two nuts (5).
3. Connect circuit 24 lead (3), circuit 22 lead (2), and circuit 21 lead (1) to tail light leads (4).

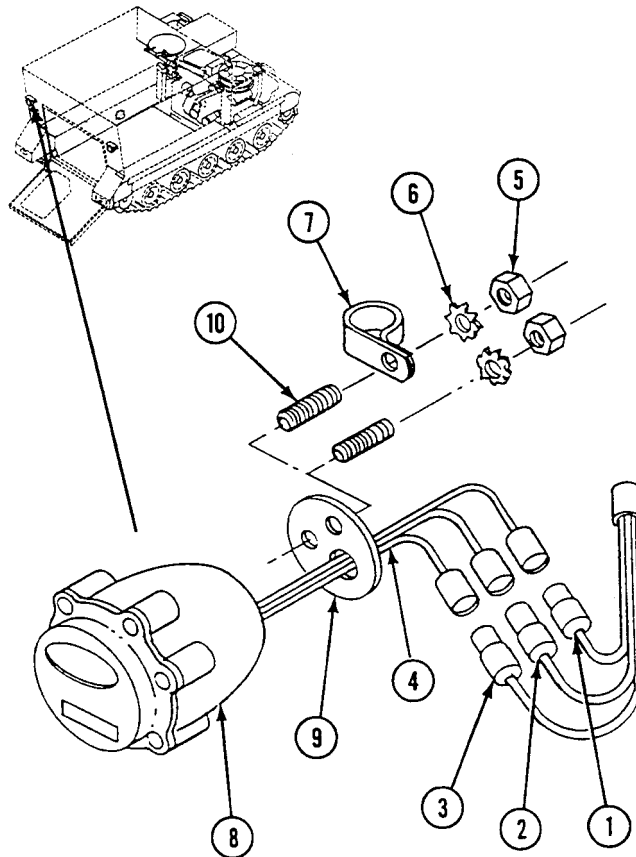
**FOLLOW-THROUGH STEPS**

1. Connect battery ground lead (WP 0338 00).
2. Turn MASTER SWITCH ON (see your -10).
3. Operate main light switches to see if left stop light-tail light is operable (see your -10). Turn light switches OFF.
4. Start engine (see your -10).
5. Raise and lock ramp (see your -10).
6. Stop engine (see your -10).

END OF TASK

REPAIR LEFT STOP LIGHT-TAIL LIGHT

0300 00

THIS WORK PACKAGE COVERS:

Disassembly (page 0300 00-1).
 Assembly (page 0300 00-2).

INITIAL SETUP:

Maintenance Level

Unit

Personnel Required

Unit Mechanic

Tools and Special Tools

General Mechanic's Tool Kit (WP 0926 00, Item 65)

References

See your -10

Materials/Parts

Preformed packing

Equipment Condition

Engine stopped (see your -10)
 Carrier blocked (see your -10)

DISASSEMBLY

1. Loosen six screws (1). Remove door (2) from light body (3).
2. Remove preformed packing (4) from door (2). Discard packing.
3. Push in on two small bulbs (5) and one large bulb (6). Turn each bulb to the left and remove from light body (3).

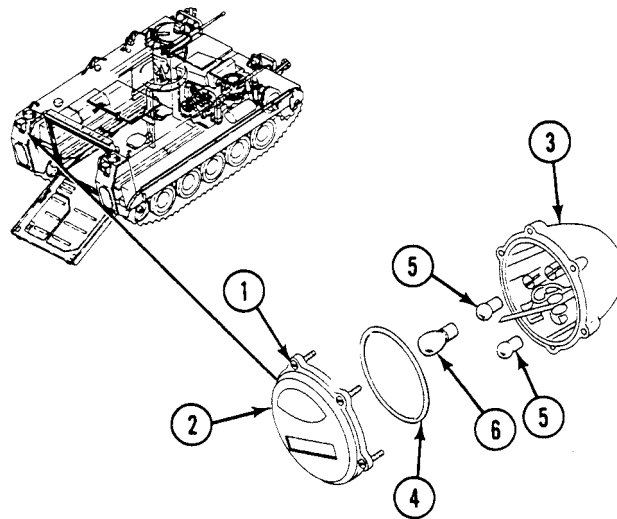

ASSEMBLY

1. Install two small bulbs (5) and one large bulb (6) in light body (3). Push in and turn to the right to secure.
2. Place new preformed packing (4) on door (2).
3. Place door (2) on light body (3). Secure with six screws (1).

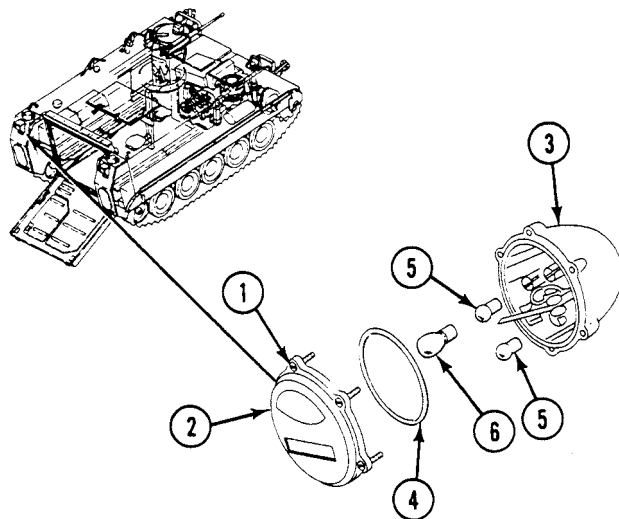
**END OF TASK**

REPLACE RIGHT STOP LIGHT-TAIL LIGHT (M577A3 ONLY)

0301 00

THIS WORK PACKAGE COVERS:

Removal (page 0301 00-1).
 Installation (page 0301 00-2).

INITIAL SETUP:

Maintenance Level

Unit

Personnel Required

Unit Mechanic

Tools and Special Tools

General Mechanic's Tool Kit (WP 0926 00, Item 65)

References

See your -10

Materials/Parts

Gasket
 Lockwasher
 Lockwasher

Equipment Condition

Engine stopped (see your -10)
 Carrier blocked (see your -10)
 Ramp lowered (see your -10)
 Battery ground lead disconnected (WP 0338 00)

REMOVAL

1. Disconnect circuit 23 lead (1) and circuit 24 lead (2) from stop light-tail light leads (3).
2. Remove nut (4), lockwasher (5), and clamp (6) from left stud (7) on stop light-tail light (8). Remove clamp from stop light-tail light leads (3). Discard lockwasher.
3. Remove nut (9) and lockwasher (10) from right stud (11) and remove stop light-tail light (8) and gasket (12) from carrier hull. Discard gasket and lockwasher.
4. If needed, remove two studs (7) and (11) from rear of stop light-tail light (8).

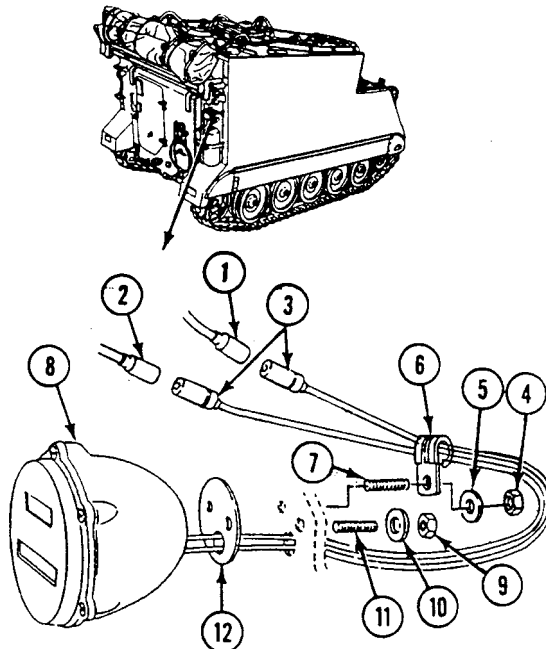

INSTALLATION

1. If removed, install two studs (7) and (11) in rear of stop light-tail light (8).
2. Install new gasket (12) and stop light-tail light (8) on carrier hull. Secure right stud (11) with new lockwasher (10) and nut (9).
3. Install clamp (6) on stop light-tail light leads (3) and secure to left stud (7) with new lockwasher (5) and nut (4).
4. Connect circuit 24 lead (2) and circuit 23 lead (1) to stop light-tail light leads (3).

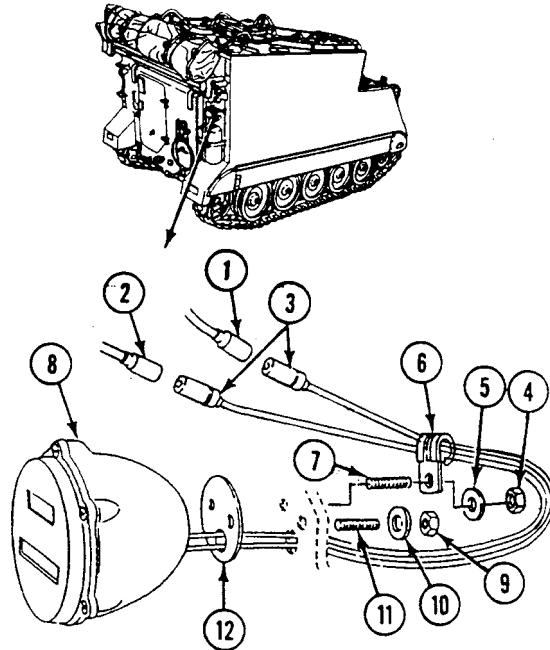
**FOLLOW-THROUGH STEPS**

1. Connect battery ground lead (WP 0338 00).
2. Turn MASTER SWITCH ON (see your -10).
3. Operate main light switches to see if right stop light-tail light is operable (see your -10). Turn light switches OFF.
4. Start engine (see your -10).
5. Raise and lock ramp (see your -10).
6. Stop engine (see your -10).

END OF TASK

REPAIR RIGHT STOP LIGHT-TAIL LIGHT

0302 00

THIS WORK PACKAGE COVERS:

Disassembly (page 0302 00-1).
 Assembly (page 0302 00-2).

INITIAL SETUP:

Maintenance Level

Unit

Personnel Required

Unit Mechanic

Tools and Special Tools

General Mechanic's Tool Kit (WP 0926 00, Item 65)

References

See your -10

Materials/Parts

Preformed packing

Equipment Condition

Engine stopped (see your -10)
 Carrier blocked (see your -10)

DISASSEMBLY

1. Loosen six screws (1). Remove door (2) from light body (3).
2. Remove preformed packing (4) from door (2). Discard packing.
3. Push in on two bulbs (5) and turn to the left. Remove bulbs from light body (3).

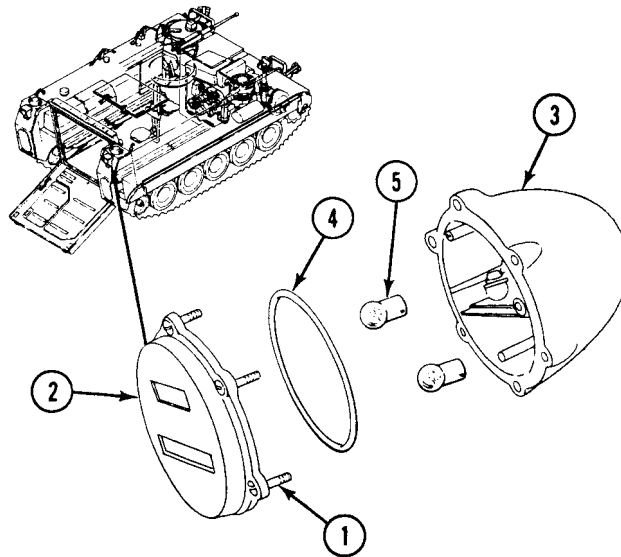

ASSEMBLY

1. Install two bulbs (5) in light body (3). Push in and turn bulbs to the right to secure.
2. Place new preformed packing (4) on door (2).
3. Place door (2) on light body (3). Secure with six screws (1).

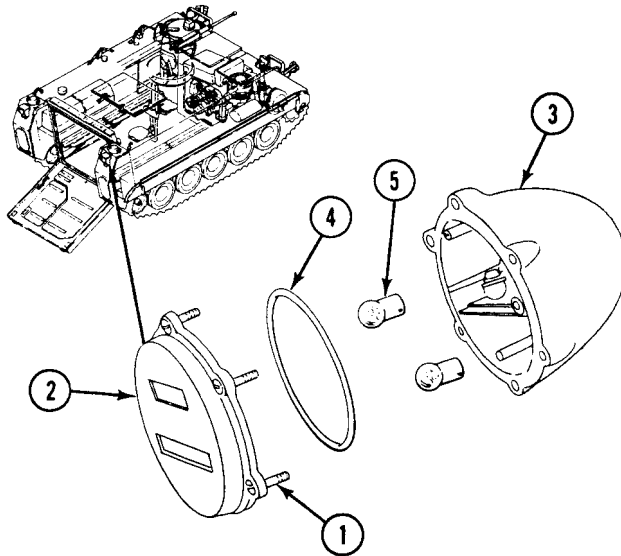
**END OF TASK**

REPLACE SERVICE AND INFRARED HEADLIGHTS

0303 00

THIS WORK PACKAGE COVERS:

Removal (page 0303 00-1).
 Installation (page 0303 00-2).

INITIAL SETUP:

Maintenance Level

Unit

References

See your -10

Tools and Special Tools

General Mechanic's Tool Kit (WP 0926 00, Item 65)

Equipment Condition

Engine stopped (see your -10)
 Carrier blocked (see your -10)
 Battery ground strap disconnected (WP 0337 00),
 (WP 0338 00), or (WP 0339 00)

Materials/Parts

Lockwasher

Personnel Required

Unit Mechanic

REMOVAL

NOTE

Except for circuit leads, service headlight and infrared headlight are replaced the same way.

1. Disconnect circuit 17 lead (1) and circuit 18 lead (2) from rear of service headlight (3).
2. Disconnect circuit 514 lead (1) and circuit 515 lead (2) from rear of infrared headlight (3).
3. Remove nut (4), lockwasher (5), small bevel washer (6), large bevel washer (7), and headlight (3) from hull bracket (8). Discard lockwasher.

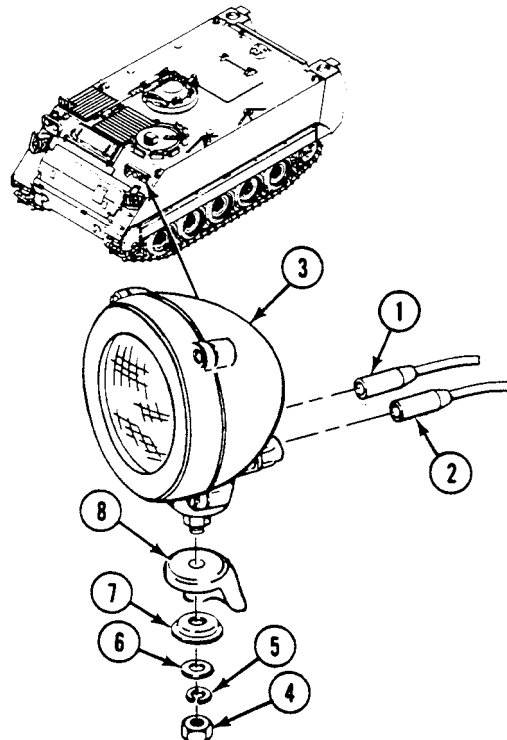

INSTALLATION

1. Place headlight (3) and large bevel washer (7) on hull bracket (8). Secure with small bevel washer (6), new lockwasher (5), and nut (4).
2. Connect circuit 18 lead (2) and circuit 17 lead (1) to rear of service headlight (3).
3. Connect circuit 515 lead (2) and circuit 514 lead (1) to rear of infrared headlight (3).

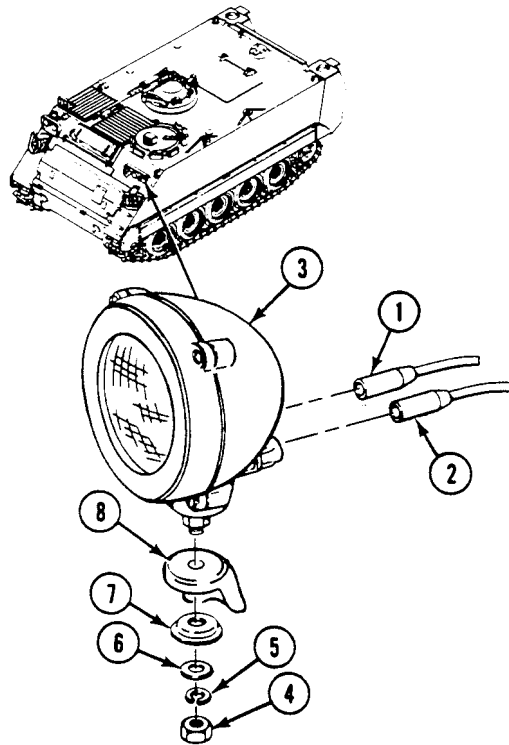
**FOLLOW-THROUGH STEPS**

1. Connect battery ground strap (WP 0337 00), (WP 0338 00), or (WP 0339 00).
2. Turn MASTER SWITCH ON (see your -10).

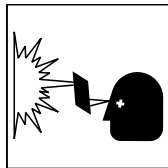
WARNING

Do not look directly into infrared headlights. You may damage your eyes.

3. Turn on service headlights to check that they work right (see your -10).
4. Turn infrared headlights on (see your -10) and hold hand near lens. Heat means headlight is working.
5. Turn all switches OFF (see your -10).

END OF TASK

REPAIR SERVICE AND INFRARED HEADLIGHTS

0304 00

THIS WORK PACKAGE COVERS:

- Inspection (page 0304 00-1).
- Disassembly (page 0304 00-2).
- Assembly (page 0304 00-3).

INITIAL SETUP:

Maintenance Level

Unit

Personnel Required

Unit Mechanic

Tools and Special Tools

General Mechanic's Tool Kit (WP 0926 00, Item 65)

References

See your -10

Materials/Parts

Gasket

Lockwasher

Preformed packing

Preformed packing

Equipment Condition

Service and/or infrared headlight removed (WP 0303 00)

INSPECTION OF INSTALLED ITEMS

INSPECTION

1. Check lens. Replace cracked or chipped lens.
2. Check lamp unit. See troubleshooting (WP 0031 00) and (WP 0032 00). Replace bad lamp unit.
3. Check door, body, and retainer plates. Replace headlight if any part is missing or damaged (WP 0303 00).

DISASSEMBLY

NOTE

Repair of service headlight and infrared headlight is the same. Service headlight has clear lens and infrared headlight has dark red lens.

1. Loosen four screws (1). Remove door (2) and preformed packing (3) from headlight body (4). Discard packing.
2. Loosen four screws (5). Remove retainer plate (6), lens (7), and gasket (8) from door (2). Discard gasket.
3. Loosen three screws (9). Remove retainer plate (10) from body (4). Pull lamp unit (11) from body.
4. Remove four screws (12), mount (13), and preformed packing (14) from body (4). Discard preformed packing.
5. Remove screw (15) and lockwasher (16) from mount (13). Discard lockwasher.

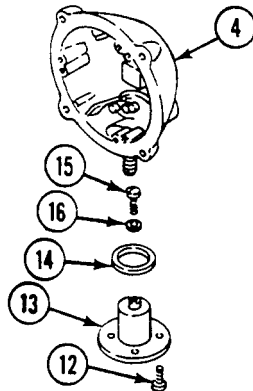
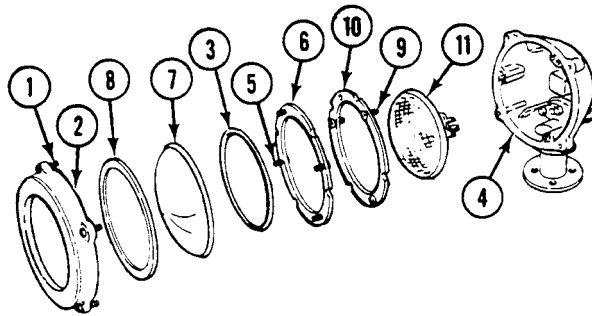

ASSEMBLY

1. Install new lockwasher (1) and screw (2) in mount (3).

CAUTION

Use care when tightening four mount screws. Do not overtighten. Overtightening the screws will strip the housing threads.

2. Install new preformed packing (4), mount (3), and four screws (5) in body (6).
3. Connect lamp unit (7) to plug in lamp body (6) with word FOG at the bottom.
4. Install lamp unit (7), retainer plate (8), and three screws (9) in body (6).
5. Install new gasket (10), lens (11), retainer plate (12), and four screws (13) in door (14).
6. Install new preformed packing (15), door (14), and four screws (16) on body (6).

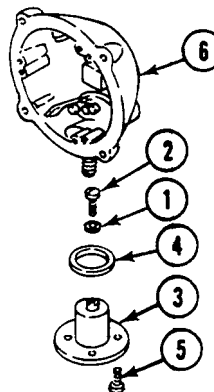
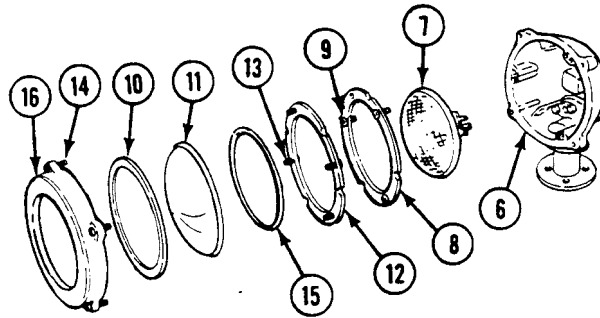

FOLLOW-THROUGH STEPS

1. Install service and/or infrared headlight (WP 0303 00).

END OF TASK

REPLACE BLACKOUT HEADLIGHT

0305 00

THIS WORK PACKAGE COVERS:

Removal (page 0305 00-1).
 Installation (page 0305 00-2).

INITIAL SETUP:

Maintenance Level

Unit

References

See your -10

Tools and Special Tools

General Mechanic's Tool Kit (WP 0926 00, Item 65)

Equipment Condition

Engine stopped (see your -10)

Carrier blocked (see your -10)

Materials/Parts

Lockwasher

Battery ground strap disconnected (WP 0337 00),
 (WP 0338 00), or (WP 0339 00)

Personnel Required

Unit Mechanic

REMOVAL

1. Disconnect circuit 19 lead (1) from rear of blackout headlight (2).
2. Remove nut (3), lockwasher (4), finishing washer (5), and blackout headlight (2) from hull bracket. Discard lockwasher.
3. Check lead and connector. Replace frayed, broken, or cracked parts (page 0382 00-1).

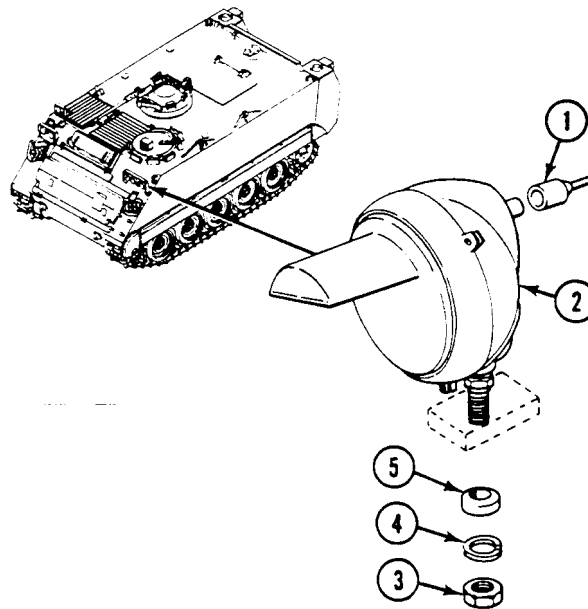

INSTALLATION

1. Install blackout headlight (2), finishing washer (5), new lockwasher (4), and nut (3) on hull bracket.
2. Connect circuit 19 lead (1) to rear of blackout headlight (2).

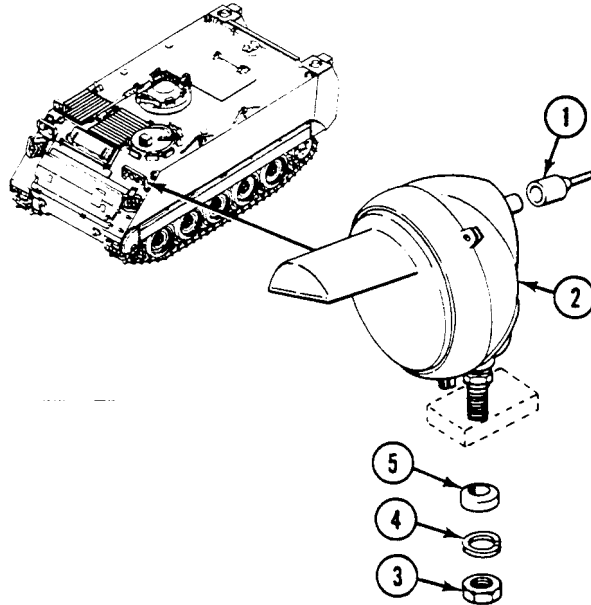
**FOLLOW-THROUGH STEPS**

1. Connect battery ground strap (WP 0337 00), (WP 0338 00), or (WP 0339 00).
2. Turn MASTER SWITCH to ON (see your -10).
3. Turn blackout headlight switch on to check that headlight works right (see your -10).
4. Turn all switches to OFF (see your -10).

END OF TASK

REPAIR BLACKOUT HEADLIGHT

0306 00

THIS WORK PACKAGE COVERS:

Disassembly (page 0306 00-1).
 Assembly (page 0306 00-2).

INITIAL SETUP:

Maintenance Level

Unit

Personnel Required

Unit Mechanic

Tools and Special Tools

General Mechanic's Tool Kit (WP 0926 00, Item 65)

References

See your -10

Materials/Parts

Lamp unit
 Retaining clip (3)

Equipment Condition

Engine stopped (see your -10)
 Carrier blocked (see your -10)

DISASSEMBLY

NOTE

Check door and body. Replace blackout headlight if any part is missing or damaged (WP 0305 00).

1. Loosen three screws (1). Pull door (2) with lamp unit (3) away from light body (4).
2. Disconnect ground lead (5) from body (4).
3. Remove three retaining clips (6) and lamp unit (3) from door (2). Discard lamp unit and clips.

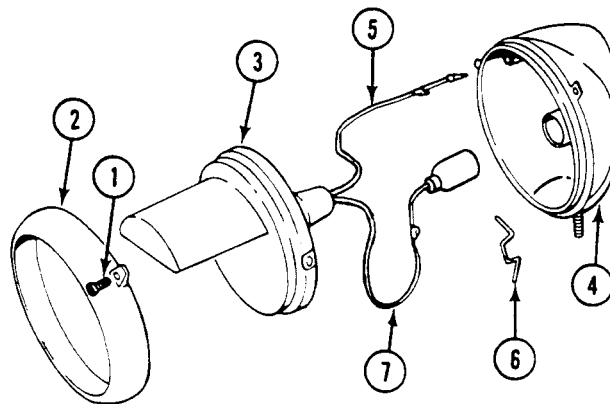

ASSEMBLY

1. Install new lamp unit (3) in door (2). Secure with three new retaining clips (6).
2. Connect positive lead (7) and ground lead (5) to light body (4).
3. Install door (2) with lamp unit (3) and three screws (1) on body (4).

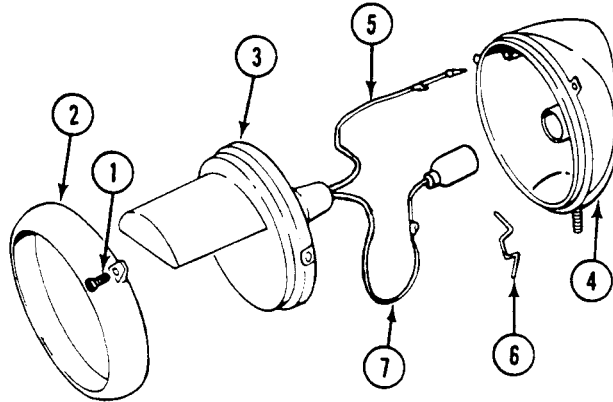
**END OF TASK**

REPLACE BLACKOUT MARKER LIGHT

0307 00

THIS WORK PACKAGE COVERS:

Removal (page 0307 00-1).
 Installation (page 0307 00-2).

INITIAL SETUP:

Maintenance Level

Unit

References

See your -10

Tools and Special Tools

General Mechanic's Tool Kit (WP 0926 00, Item 65)

Equipment Condition

Engine stopped (see your -10)

Carrier blocked (see your -10)

Materials/Parts

Lockwasher

Battery ground strap disconnected (WP 0337 00),
 (WP 0338 00), or (WP 0339 00)

Personnel Required

Unit Mechanic

REMOVAL

1. Disconnect circuit 20 lead (1) from rear of blackout marker light (2).
2. Remove nut (3), washer (4), lockwasher (5), and marker light (2) from hull bracket. Discard lockwasher.

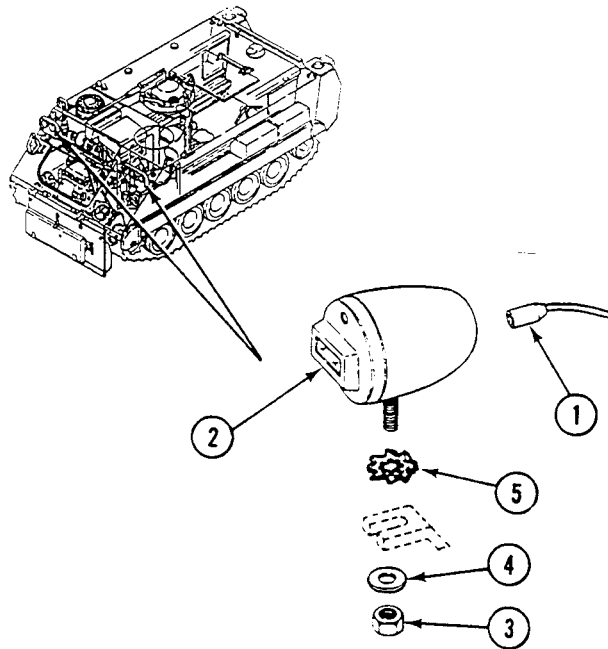

INSTALLATION

1. Install blackout marker light (2), new lockwasher (5), washer (4), and nut (3) on hull bracket.
2. Connect circuit 20 lead (1) to rear of marker light (2).

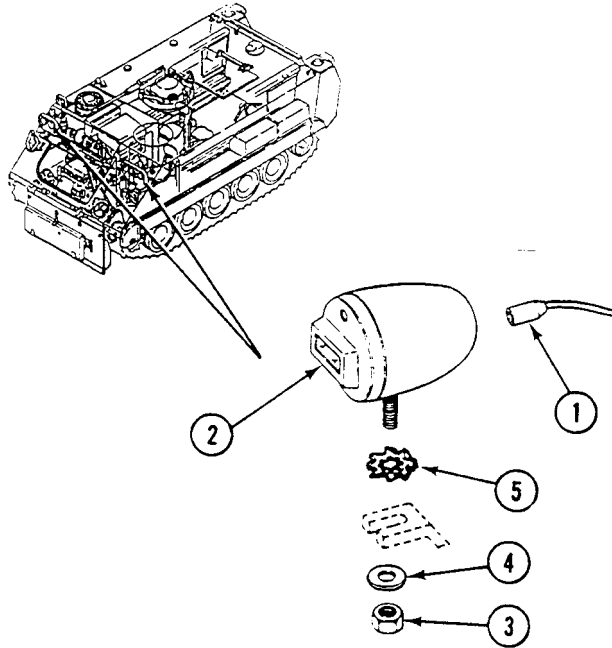
**FOLLOW-THROUGH STEPS**

1. Connect battery ground strap (WP 0337 00), (WP 0338 00), or (WP 0339 00).
2. Turn MASTER SWITCH ON (see your -10).
3. Turn blackout marker light switch on to check that light works right (see your -10).
4. Turn all switches OFF (see your -10).

END OF TASK

REPAIR BLACKOUT MARKER LIGHT

0308 00

THIS WORK PACKAGE COVERS:

Disassembly (page 0308 00-1).
 Assembly (page 0308 00-2).

INITIAL SETUP:

Maintenance Level

Unit

Personnel Required

Unit Mechanic

Tools and Special Tools

General Mechanic's Tool Kit (WP 0926 00, Item 65)

References

See your -10

Materials/Parts

Gasket
 Light bulb (as needed)

Equipment Condition

Engine stopped (see your -10)
 Carrier blocked (see your -10)

DISASSEMBLY

1. Loosen two screws (1). Remove door (2) and gasket (3) from light body (4). Discard gasket.
2. Push in on bulb (5) and turn to the left. Remove bulb from body (4).

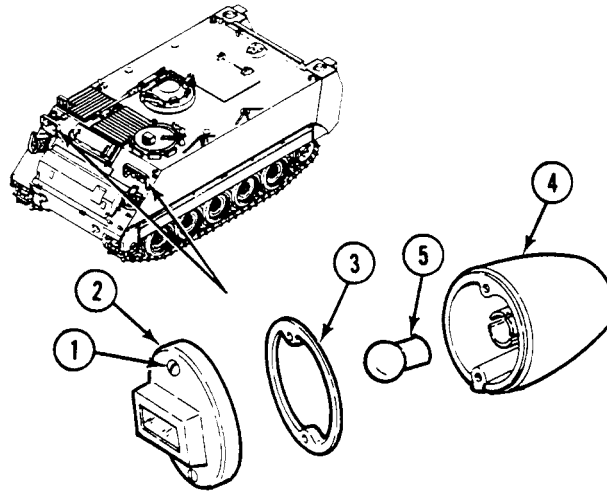

ASSEMBLY

1. Place bulb (5) in light body (4). Push in on bulb and turn to the right to secure.
2. Install new gasket (3), door (2), and two screws (1) on body (4).

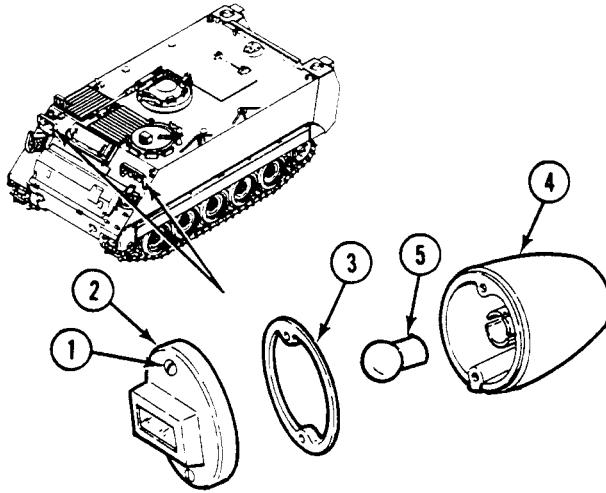
**END OF TASK**

REPLACE DOME LIGHT (ALL EXCEPT M577A3 AND M1068A3)

0309 00

THIS WORK PACKAGE COVERS:

Removal (page 0309 00-1).
 Installation (page 0309 00-2).

INITIAL SETUP:

Maintenance Level

Unit

Personnel Required

Unit Mechanic

Tools and Special Tools

General Mechanic's Tool Kit (WP 0926 00, Item 65)

References

See your -10

Materials/Parts

Lockwasher (4)
 Locknut (4)

Equipment Condition

Engine stopped (see your -10)
 Carrier blocked (see your -10)
 Battery ground strap disconnected (WP 0337 00),
 (WP 0338 00), or (WP 0339 00)

REMOVAL

NOTE

All dome lights are replaced the same way.

1. Disconnect circuit 38 lead (1) from rear of dome light (2).
2. Remove four screws (3), lockwashers (4), locknuts (5), and dome light (2) from two mount brackets (6). Discard lockwashers and locknuts.

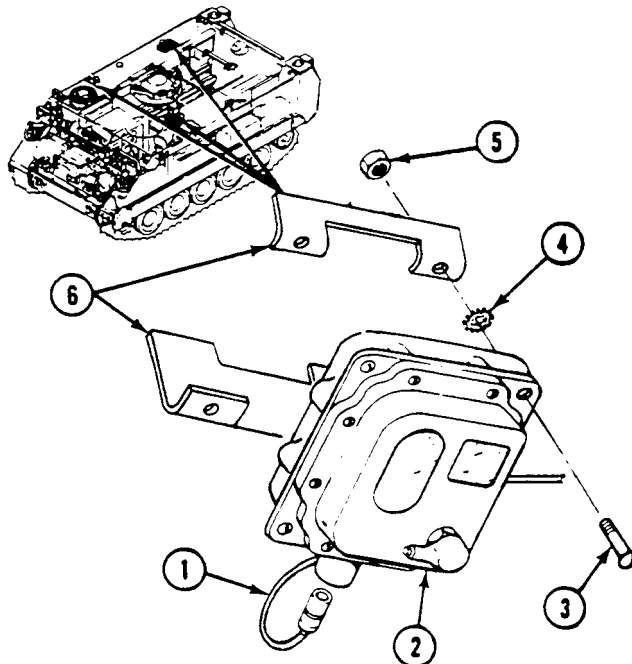

INSTALLATION

1. Place dome light (2) on two mount brackets (6). Slide four new lockwashers (4), one at a time, between dome light and mount bracket (5) and secure with screws (3) and new locknuts (5).
2. Connect circuit 38 lead (1) to rear of dome light (2).

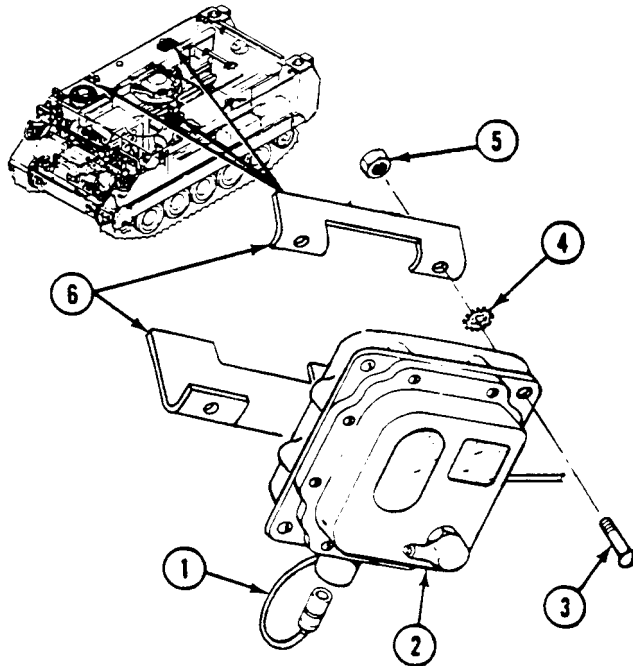
**FOLLOW-THROUGH STEPS**

1. Connect battery ground strap (WP 0337 00), (WP 0338 00), or (WP 0339 00).
2. Turn MASTER SWITCH ON (see your -10).
3. Turn dome light switch on and off to check that light works (see your -10).
4. Turn MASTER SWITCH OFF (see your -10).

END OF TASK

REPAIR DOME LIGHT (ALL EXCEPT M577A3 AND M1068A3)

0310 00

THIS WORK PACKAGE COVERS:

Disassembly (page 0310 00-1).
 Assembly (page 0310 00-3).

INITIAL SETUP:

Maintenance Level

Unit

Personnel Required

Unit Mechanic

Tools and Special Tools

General Mechanic's Tool Kit (WP 0926 00, Item 65)

References

See your -10

Materials/Parts

Seal
 Bulb
 Bulb

Equipment Condition

Engine stopped (see your -10)
 Carrier blocked (see your -10)
 Dome light removed (WP 0309 00)

DISASSEMBLY

NOTE

If dome light door mounting screw separates from door, replace retaining clip.

1. Remove eight screws (1) and door (2) from dome light body (3).

2. Remove seal (4) from door (2).
3. Push in on light bulb (5) and blackout bulb (6), and turn to the left. Remove and discard two bulbs.

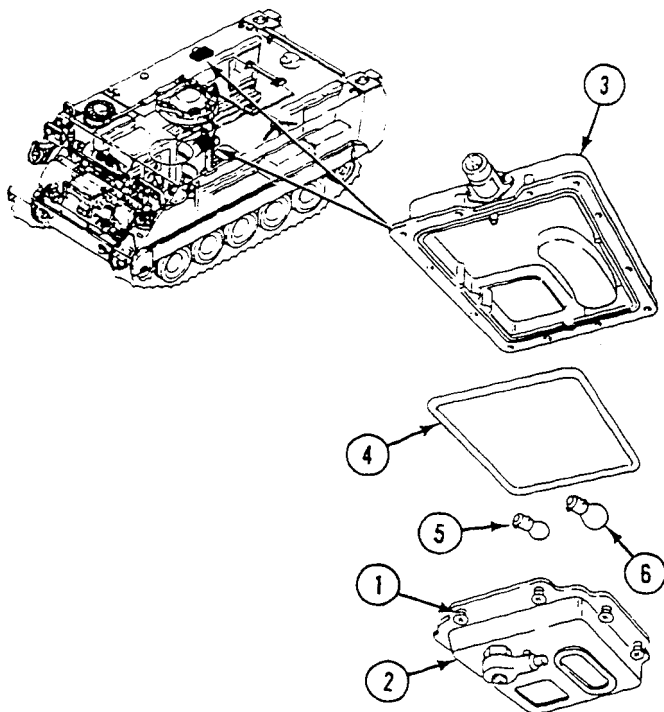

ASSEMBLY

1. Install new blackout bulb (6) and new light bulb (5) in door (2). Push in and turn bulbs to the right to secure.
2. Install new seal (4) on door (2).
3. Install door (2) on dome light body (3). Secure with eight screws (1).

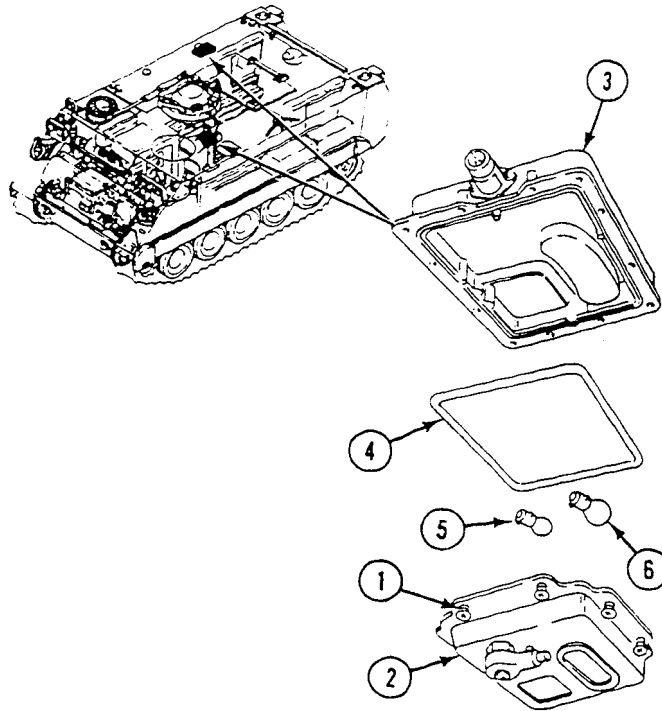
**FOLLOW-THROUGH STEPS**

1. Install dome light (WP 0309 00).

END OF TASK

REPLACE DOME LIGHT (M577A3 AND M1068A3 ONLY)

0311 00

THIS WORK PACKAGE COVERS:

Removal (page 0311 00-1).
 Installation (page 0311 00-3).

INITIAL SETUP:

Maintenance Level

Unit

Personnel Required

Unit Mechanic

Tools and Special Tools

General Mechanic's Tool Kit (WP 0926 00, Item 65)

References

See your -10

Materials/Parts

Lockwasher (4)

Equipment Condition

Engine stopped (see your -10)
 Carrier blocked (see your -10)

REMOVAL

NOTE

There are nine dome lights and two blackout lights in the M577A3 and M1068A3. All lights are replaced the same way.

1. Disconnect ground lead (1) from dome light (2).
2. Disconnect lead (3) from dome light (2).

NOTE

Disconnect circuit 38C lead from dome lights or circuit 38B lead from blackout lights.

3. Loosen screw (4). Lower door (5) on dome light (2).
4. Remove four nuts (6), lockwashers (7), screws (8), and light (2) from mount (9). Discard lockwashers.

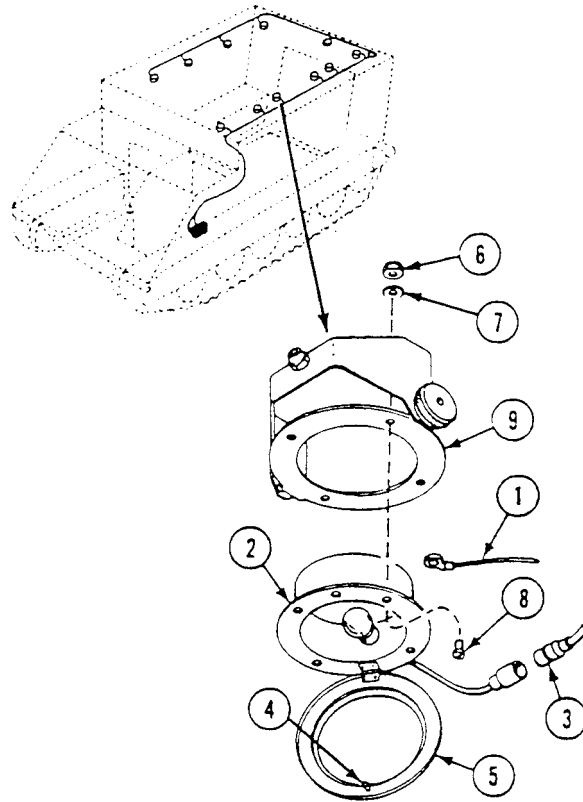

INSTALLATION

1. Place light (2) on mount (9). Secure with four screws (8), new lockwashers (7), and nuts (6).
2. Close door (5) on light (2). Secure with screw (4).
3. Connect lead (3) to light (2).

NOTE

Connect circuit 38C lead to dome lights or circuit 38B lead to blackout lights.

4. Connect ground lead (1) to dome light (2).

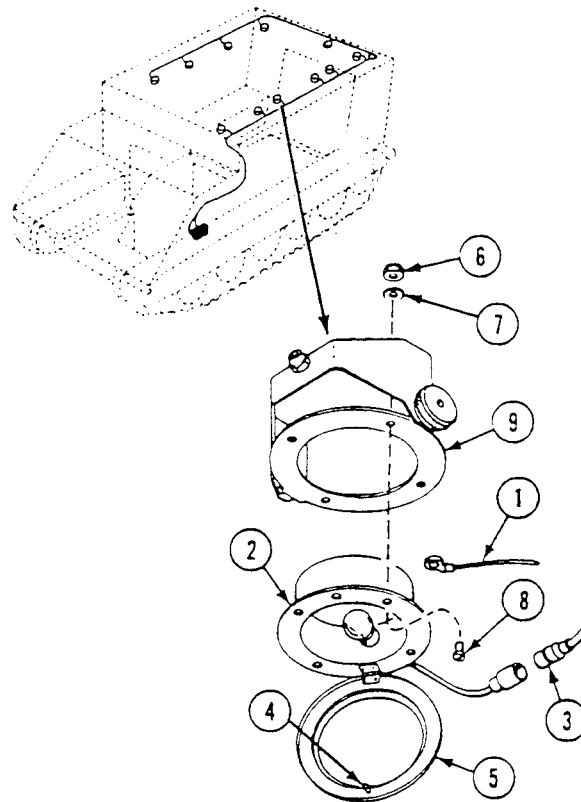
**FOLLOW-THROUGH STEPS**

1. Turn MASTER SWITCH ON (see your -10).
2. Operate dome light or blackout light to check that light operates properly (see your -10).
3. Turn all switches OFF (see your -10).

END OF TASK

REPAIR DOME LIGHT AND MOUNT (M577A3 AND M1068A3 ONLY)

0312 00

THIS WORK PACKAGE COVERS:

Disassembly (page 0312 00-1).
 Assembly (page 0312 00-3).

INITIAL SETUP:

Maintenance Level

Unit

Personnel Required

Unit Mechanic

Tools and Special Tools

General Mechanic's Tool Kit (WP 0926 00, Item 65)

References

See your -10

Materials/Parts

Sealing Compound (WP 0928 00, Item 53)
 Locknut (6)

Equipment Condition

Engine stopped (see your -10)
 Carrier blocked (see your -10)
 Dome light removed (WP 0311 00)

DISASSEMBLY

1. Inspect dome light and dome light mount as follows:
 - a. Check lamp (4). Replace burned-out or cracked lamp.
 - b. Check lens (1). Replace cracked or chipped lens.
 - c. Check seal (3) and mounts. Replace cut, cracked, or hard seal and mounts.
 - d. Check plate (10) and bracket (11). Replace any cracked or deformed parts.
 - e. Check threaded parts. Remove burrs. Replace parts that have stripped threads.

2. Disassemble dome light as follows:

- a. Remove lens (1) and seal (2) from light door (3).
- b. Push in and turn lamp (4) to the left. Remove lamp from light body (5).

NOTE

Disassemble and assemble dome lights and blackout lights the same way. Lens in dome light is clear. Lens in blackout light is dark (nine dome lights, two blackout lights).

3. Disassemble dome light mount as follows:

- a. Remove knob (6), nut (7), two small washers (8), two large gaskets (9), and mount plate (10) from bracket (11).
- b. Remove two large gaskets (9) from plate (10).
- c. Remove six locknuts (12), three washers (13), mount (14), and bracket (11) from hull mounts (15). Discard locknuts.

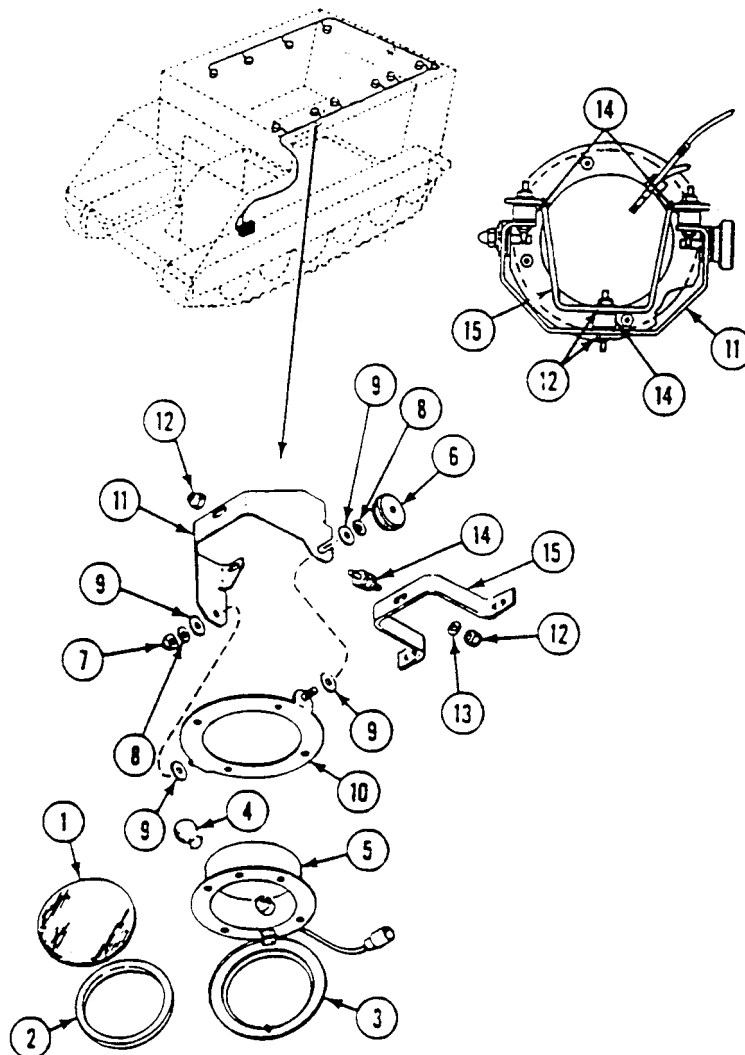

ASSEMBLY

1. Assemble dome light mount as follows:
 - a. Install three mounts (1) between bracket (2) and hull mount (3). Secure with six new locknuts (4) and three washers (5).
 - b. Place two large gaskets (6) on mount plate (7). Install plate and large gaskets on bracket (2). Secure with small washers (8), nut (9), and knob (10).
2. Assemble dome light as follows:
 - a. Install lamp (11) in light body (12). Push in and turn to the right to secure lamp.
 - b. Apply sealing compound to inside of door (13). Install seal (14) and lens (15) on door.

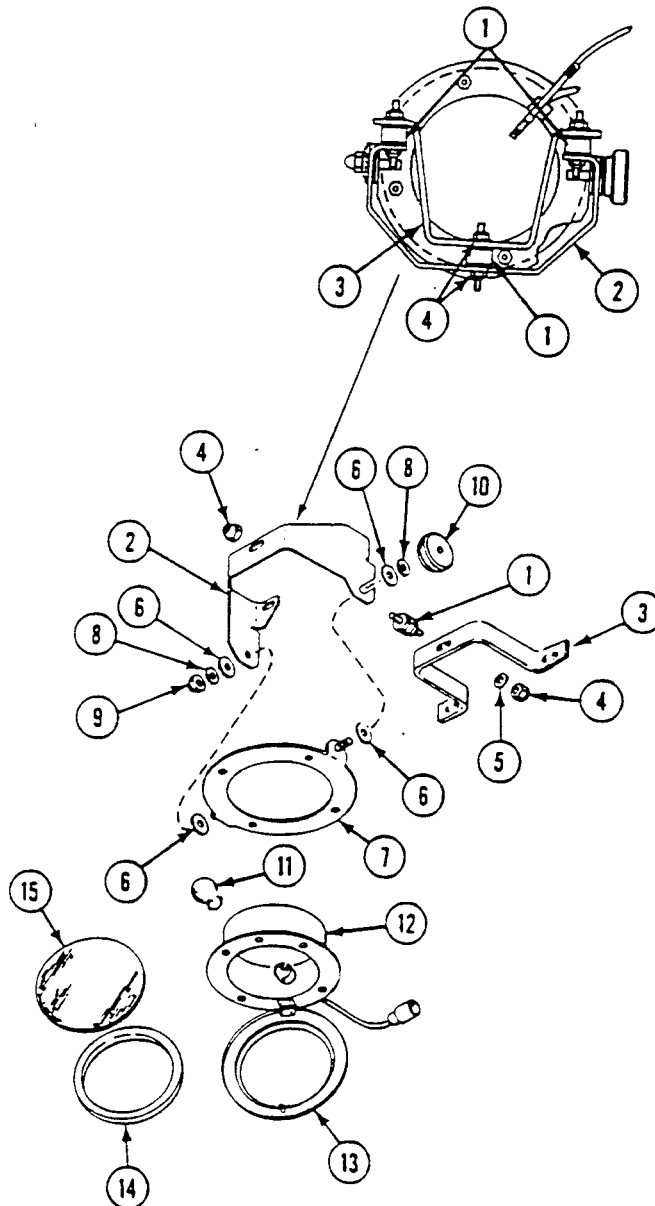

FOLLOW-THROUGH STEPS

1. Install dome light (WP 0311 00).

END OF TASK

REPLACE DOME LIGHT LENS (ALL EXCEPT M577A3 AND M1068A3)

0313 00

THIS WORK PACKAGE COVERS:

Removal (page 0313 00-1).
 Installation (page 0313 00-3).

INITIAL SETUP:

Maintenance Level

Unit

References

See your -10

Tools and Special Tools

General Mechanic's Tool Kit (WP 0926 00, Item 65)

Equipment Condition

Engine stopped (see your -10)

Personnel Required

Unit Mechanic

Carrier blocked (see your -10)

REMOVAL

1. Disconnect lead (1) from dome light (2).

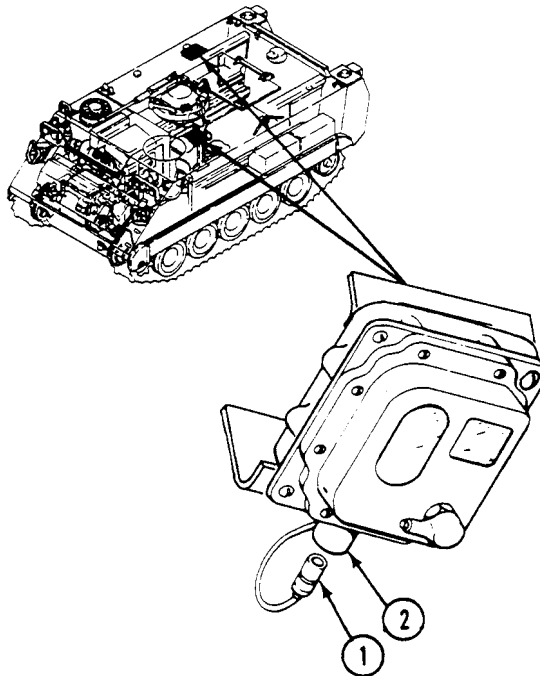

REPLACE DOME LIGHT LENS (ALL EXCEPT M577A3 AND M1068A3) — Continued

0313 00

2. Remove eight screws (3), seal (4), and door (5) from dome light body (6).
3. Remove screw (7), washer (8), and lead (9) from switch (10).

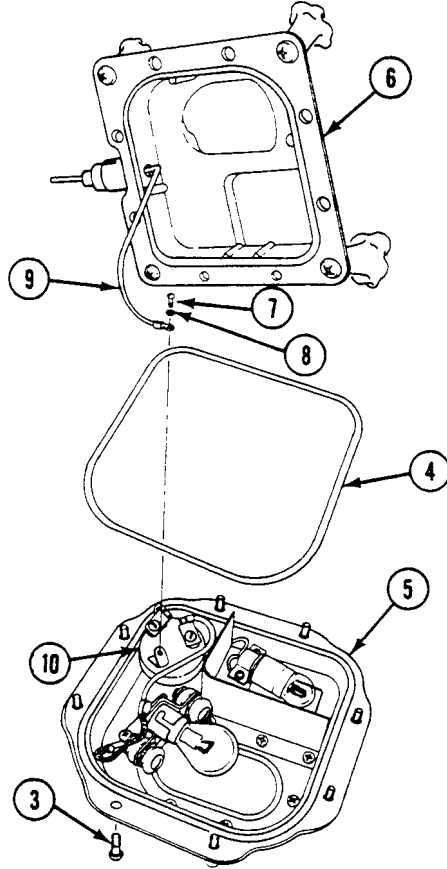

4. Remove two screws (1), lockwashers (2), and ground lead (3) from lampholder (4).
5. Remove four screws (5), lockwashers (6), and partition (7) from door (8).

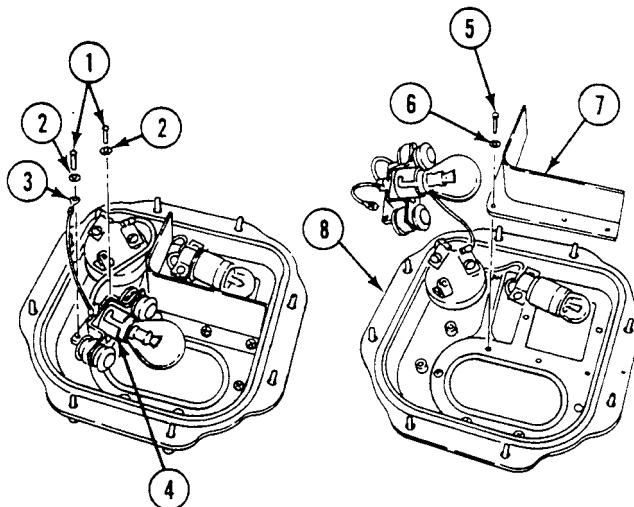

REPLACE DOME LIGHT LENS (ALL EXCEPT M577A3 AND M1068A3) — Continued

0313 00

6. Remove two screws (9), washers (10), and ground lead (11) from lampholder (12).
7. Remove seven screws (13) and lens retaining plate (14) from door (8).
8. Remove two lenses (15) and (16) and gaskets (17) and (18) from door (8).

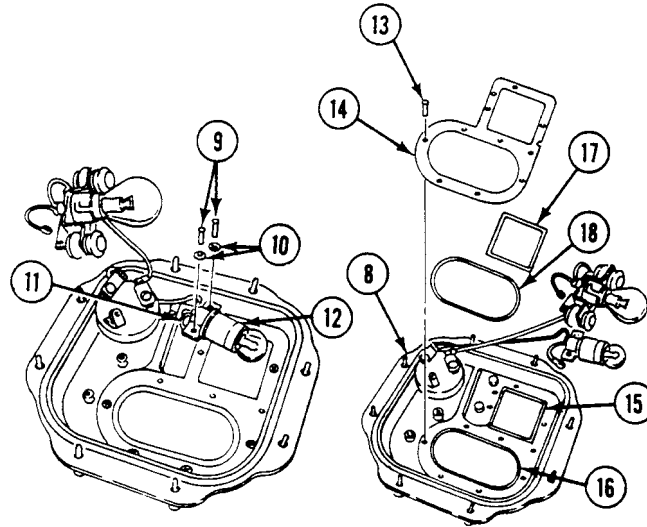
**INSTALLATION**

1. Install two lenses (15) and (16) and gaskets (17) and (18) on door (8).
2. Install lens retaining plate (14) on door (8). Secure with seven screws (13).
3. Install ground lead (11) on lampholder (12). Secure with two washers (10) and screws (9).

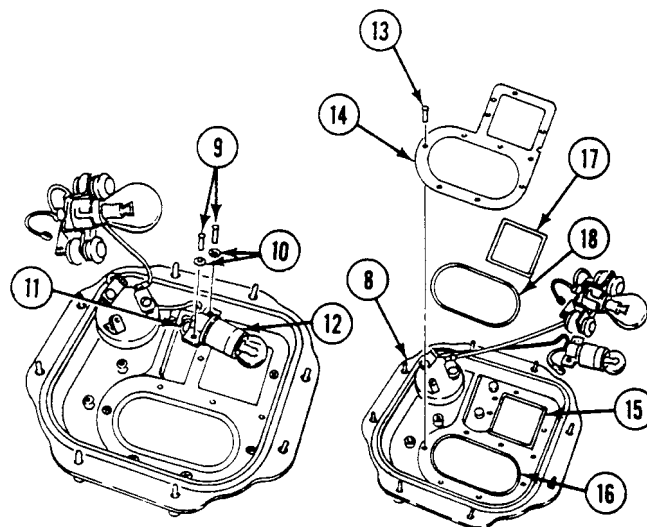

REPLACE DOME LIGHT LENS (ALL EXCEPT M577A3 AND M1068A3) — Continued

0313 00

4. Install partition (7) on door (8). Secure with four screws (5) and lockwashers (6).
5. Install ground lead (3) on lampholder (4). Secure with two screws (1) and lockwashers (2).

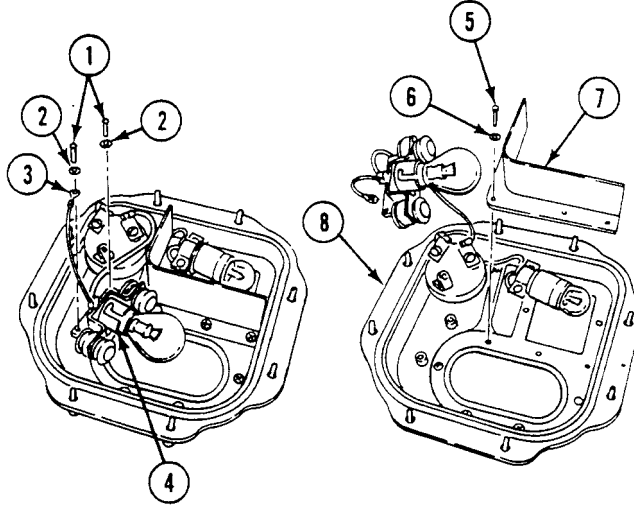

6. Install lead (1) on switch (2). Secure with screw (3) and washer (4).
7. Install seal (5) on door (6). Install door (6) on body (7). Secure with eight screws (8).

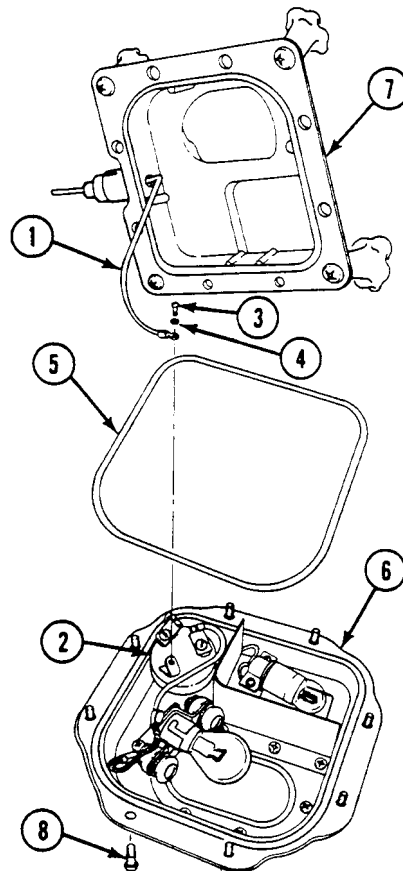

8. Connect lead (9) to dome light (10).

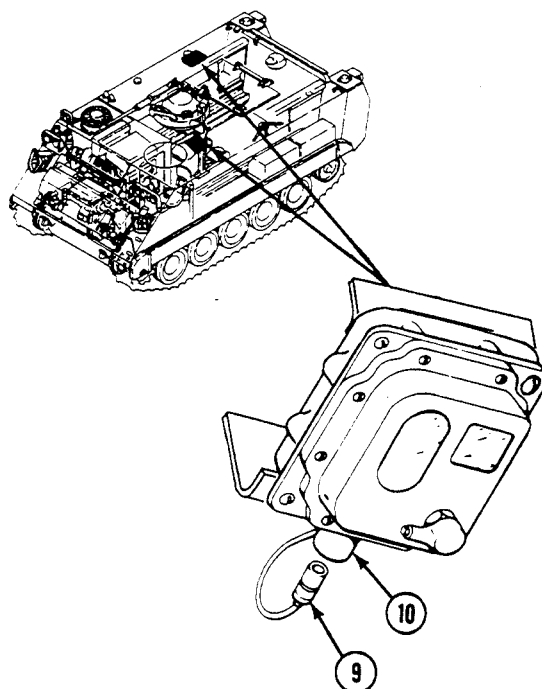
**FOLLOW-THROUGH STEPS**

1. Turn MASTER SWITCH ON (see your -10).
2. Turn dome light switch on and off to check that light works (see your -10).
3. Turn MASTER SWITCH OFF (see your -10).

END OF TASK

REPLACE FRONT DOME LIGHT SWITCH (M577A3 AND M1068A3 ONLY)

0314 00

THIS WORK PACKAGE COVERS:

Removal (page 0314 00-1).
 Installation (page 0314 00-3).

INITIAL SETUP:

Maintenance Level

Unit

Personnel Required

Unit Mechanic

Tools and Special Tools

General Mechanic's Tool Kit (WP 0926 00, Item 65)

References

See your -10

Materials/Parts

Gasket
 Locknut (8)

Equipment Condition

Engine stopped (see your -10)
 Carrier blocked (see your -10)
 Battery ground lead disconnected (WP 0338 00)

REMOVAL

1. Remove eight locknuts (1), washers (2), screws (3), and master switch panel (4) from distribution box (5). Discard locknuts.

2. Disconnect circuit 38 lead (6), circuit 38A lead (7), and circuit 10 lead (8) from front dome light switch (10).
3. Remove two screws (9) and front dome switch (10) from master switch panel (4).
4. Inspect gasket (11). Replace if damaged.

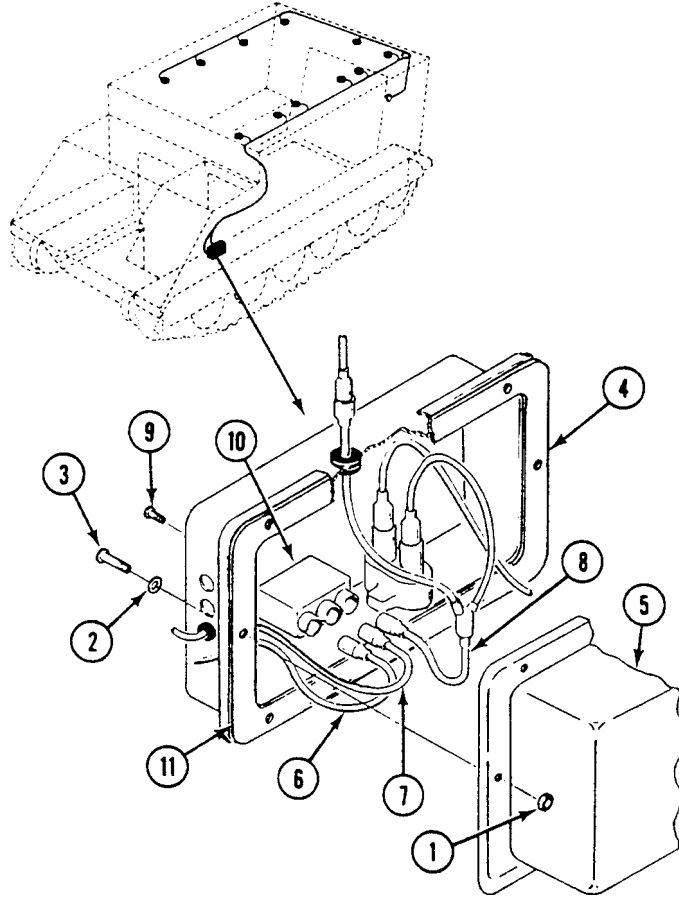

INSTALLATION

1. Install front dome switch (10) in master switch panel (4). Secure with two screws (9).
2. Connect circuit 10 lead (8), circuit 38A lead (7), and circuit 38 lead (6) to front dome light switch (10).
3. Install master switch panel (4) on distribution box (5). Secure with eight screws (3), washers (2), and new locknuts (1).

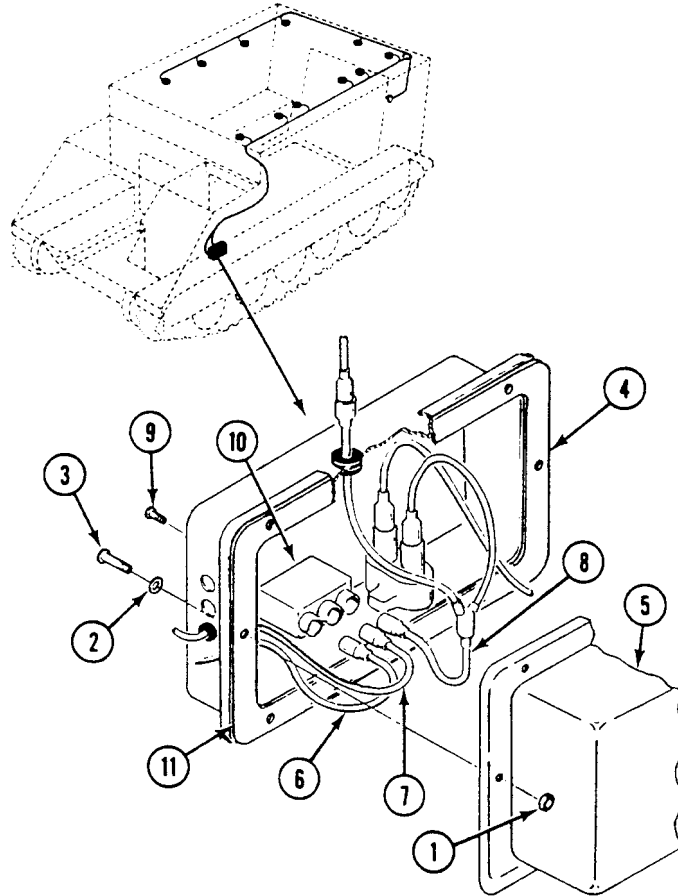

FOLLOW-THROUGH STEPS

1. Connect battery ground lead (WP 0338 00).
2. Turn MASTER SWITCH ON (see your -10).
3. Turn on front dome light switch to check that switch is operable (see your -10). Dome light should come on.
4. Turn all switches OFF (see your -10).

END OF TASK

REPLACE REAR DOME LIGHT SWITCH (M577A3 AND M1068A3 ONLY)

0315 00

THIS WORK PACKAGE COVERS:

Removal (page 0315 00-1).
 Installation (page 0315 00-2).

INITIAL SETUP:

Maintenance Level

Unit

References

See your -10

Tools and Special Tools

General Mechanic's Tool Kit (WP 0926 00, Item 65)

Equipment Condition

Engine stopped (see your -10)

Personnel Required

Unit Mechanic

Carrier blocked (see your -10)

Battery ground lead disconnected (WP 0338 00)

REMOVAL

1. Disconnect circuit 38 lead (1), circuit 38A lead (2), and circuit 38E lead (3) from rear dome light switch (5).
2. Remove two screws (4) and rear dome light switch (5) from hull bracket (6).

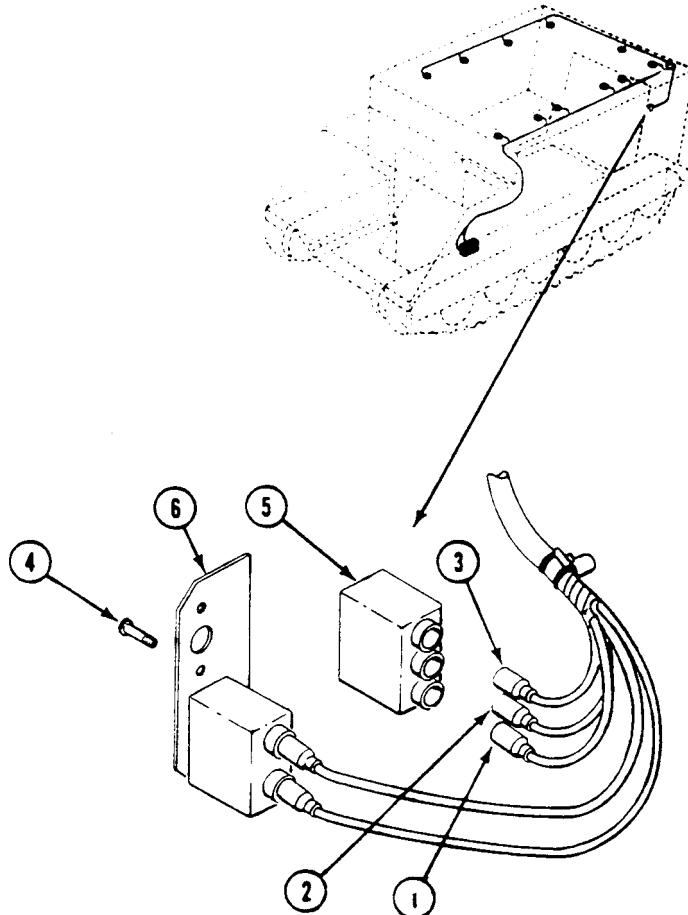

INSTALLATION

1. Install rear dome light switch (5) on hull bracket (6). Secure with two screws (4).
2. Connect circuit 38E lead (3), circuit 38A lead (2), and circuit 38 lead (1) to rear dome light switch.

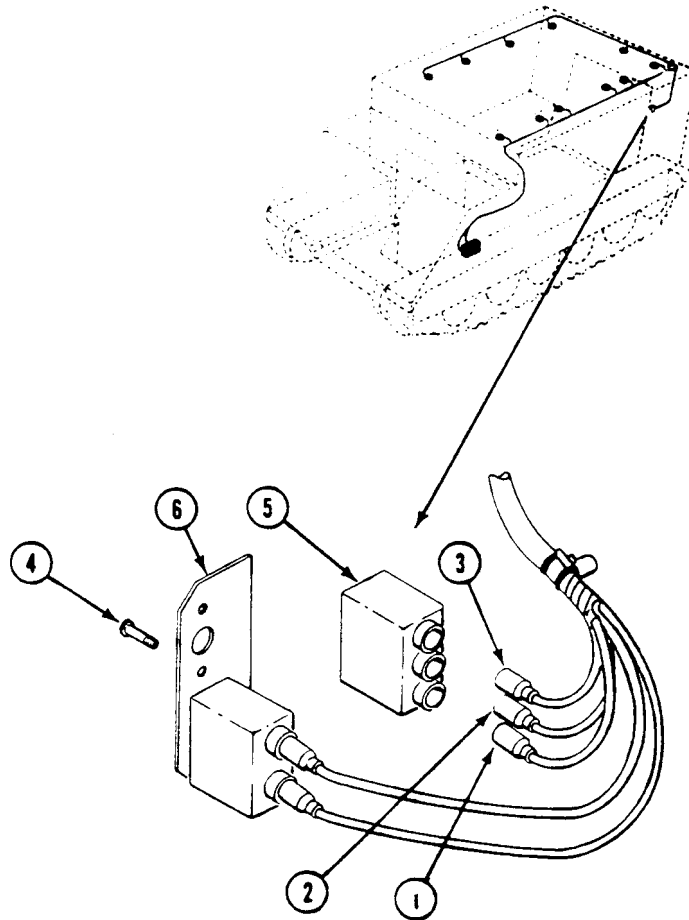
**FOLLOW-THROUGH STEPS**

1. Connect battery ground lead (WP 0338 00).
2. Turn MASTER SWITCH ON (see your -10).
3. Turn REAR DOME LIGHT SWITCH ON (see your -10). Check that switch operates properly and dome light comes on.
4. Turn all switches OFF (see your -10).

END OF TASK

REPLACE DOME LIGHT CIRCUIT BREAKER (M577A3 AND M1068A3 ONLY)

0316 00

THIS WORK PACKAGE COVERS:

Removal (page 0316 00-1).
 Installation (page 0316 00-3).

INITIAL SETUP:

Maintenance Level

Unit

Personnel Required

Unit Mechanic

Tools and Special Tools

General Mechanic's Tool Kit (WP 0926 00, Item 65)

References

See your -10

Materials/Parts

Gasket
 Locknut (8)

Equipment Condition

Engine stopped (see your -10)
 Carrier blocked (see your -10)
 Battery ground lead disconnected (WP 0338 00)

REMOVAL

1. Remove eight locknuts (1), washers (2), screws (3), and master switch panel (4) from distribution box (5). Discard locknuts.

REPLACE DOME LIGHT CIRCUIT BREAKER (M577A3 AND M1068A3 ONLY) —**0316 00****Continued**

2. Disconnect two circuit 10 leads (6) from circuit breaker (7).
3. Remove two nuts (8), screws (9), and circuit breaker (7) from master switch panel (4).
4. Inspect gasket (10). Replace if damaged.

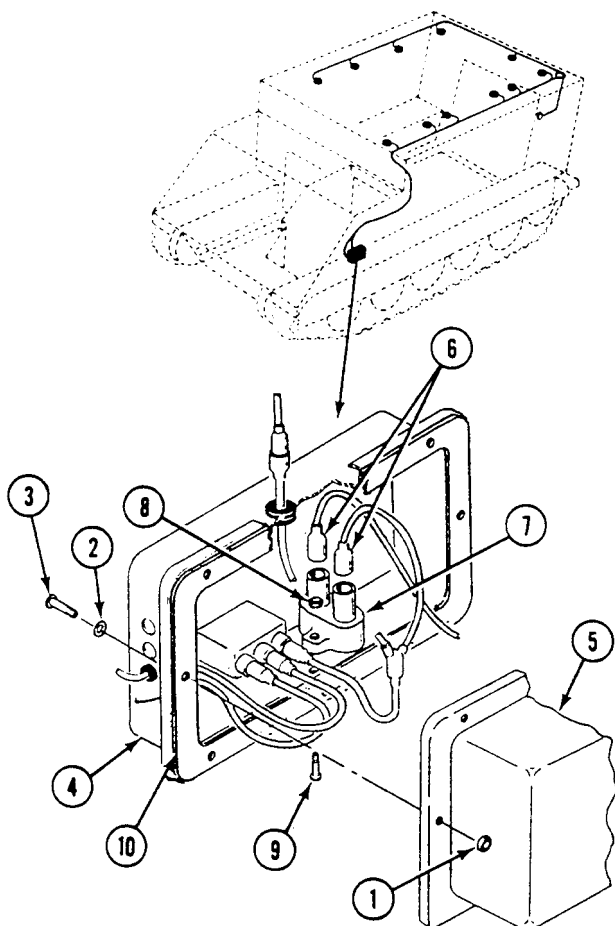

**REPLACE DOME LIGHT CIRCUIT BREAKER (M577A3 AND M1068A3 ONLY) —
Continued**

0316 00

INSTALLATION

1. Place circuit breaker (7) in master switch panel (4). Secure with two screws (9) and nuts (8).
2. Connect two circuit 10 leads (6) to circuit breaker (7).
3. Place master switch panel (4) on distribution box (5). Secure with eight screws (3), washers (2), and new locknuts (1).

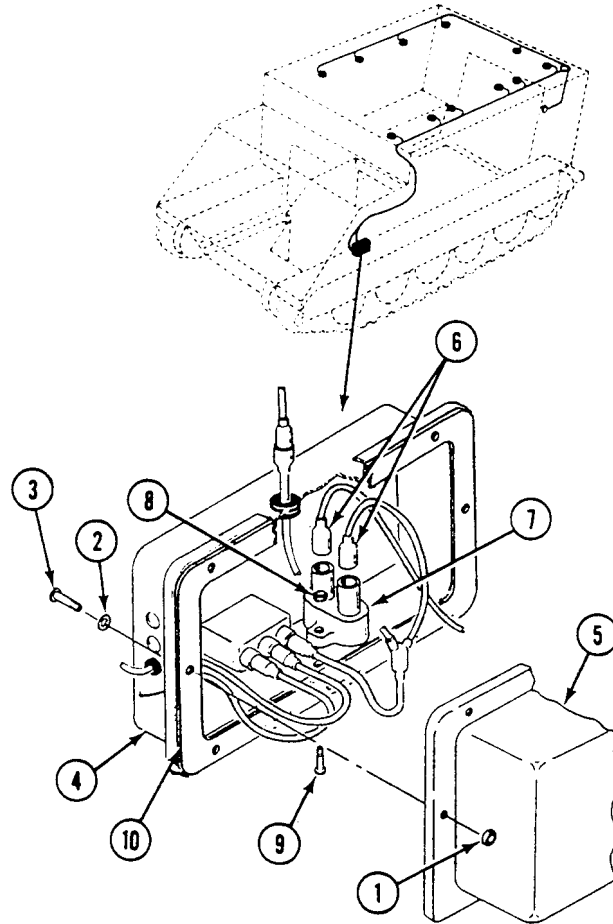

FOLLOW-THROUGH STEPS

1. Connect battery ground lead (WP 0338 00).
2. Turn MASTER SWITCH ON (see your -10).
3. Operate dome lights to check that circuit breaker is operable (see your -10).
4. Turn all switches OFF (see your -10).

END OF TASK

REPLACE DOME BLACKOUT LIGHT BYPASS SWITCH (M577A3 AND M1068A3 ONLY)

0317 00

THIS WORK PACKAGE COVERS:

Removal (page 0317 00-1).
 Installation (page 0317 00-2).

INITIAL SETUP:

Maintenance Level

Unit

References

See your -10

Tools and Special Tools

General Mechanic's Tool Kit (WP 0926 00, Item 65)

Equipment Condition

Engine stopped (see your -10)

Personnel Required

Unit Mechanic

Carrier blocked (see your -10)

Battery ground lead disconnected (WP 0338 00)

REMOVAL

1. Disconnect circuit 38B lead (1) and circuit 38E lead (2) from rear of bypass switch (3).
2. Remove two screws (4) and switch (3) from hull bracket (5).

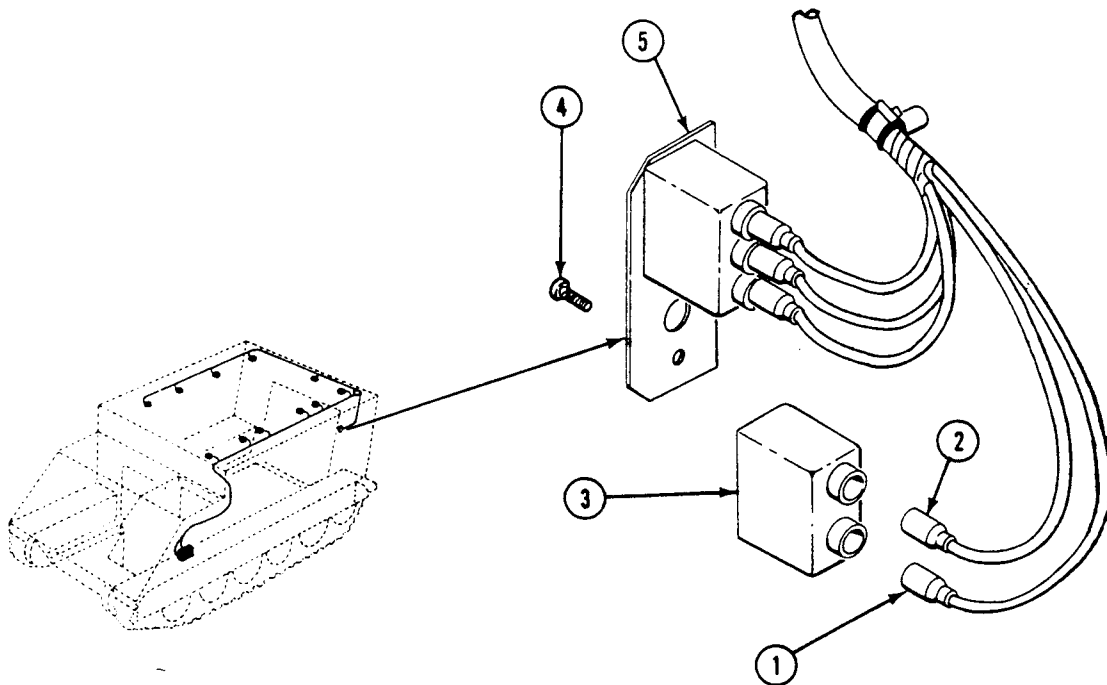

REPLACE DOME BLACKOUT LIGHT BYPASS SWITCH (M577A3 AND M1068A3 ONLY) —
Continued

0317 00

INSTALLATION

1. Place switch (3) on hull bracket (5). Secure with two screws (4).
2. Connect circuit 38E lead (2) and circuit 38B lead (1) to rear of bypass switch (3).

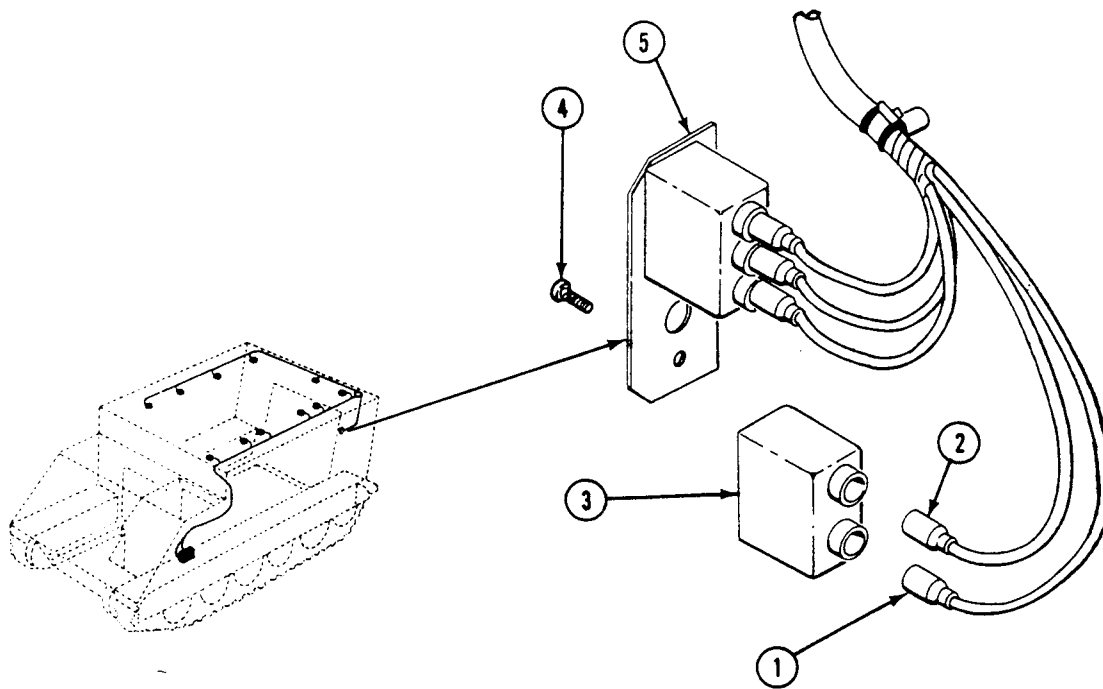
**FOLLOW-THROUGH STEPS**

1. Connect battery ground lead (WP 0338 00).
2. Turn MASTER SWITCH ON (see your -10).
3. Operate dome lights and bypass switch to check that switch operates properly (see your -10).
4. Turn all switches OFF (see your -10).

END OF TASK

REPLACE TENT LIGHT ASSEMBLY (M577A3 AND M1068A3 ONLY)

0318 00

THIS WORK PACKAGE COVERS:

Removal (page 0318 00-1).
 Installation (page 0318 00-3).

INITIAL SETUP:

Maintenance Level

Unit

References

See your -10

Tools and Special Tools

General Mechanic's Tool Kit (WP 0926 00, Item 65)

Equipment Condition

Materials/Parts

Lamp

Engine stopped (see your -10)

Personnel Required

Unit Mechanic

Carrier blocked (see your -10)

Battery ground lead disconnected (WP 0338 00)

REMOVAL

1. Remove connector (1) from utility outlet receptacle (2) on rear bulkhead.
2. Remove light assembly (3) from tent supports.

INSTALLATION

1. Install new lamp (4) in light assembly (3). Push in and turn to the right to secure lamp.
2. Hang light assembly (3) on tent supports.
3. Install connector (1) on utility outlet receptacle (2).

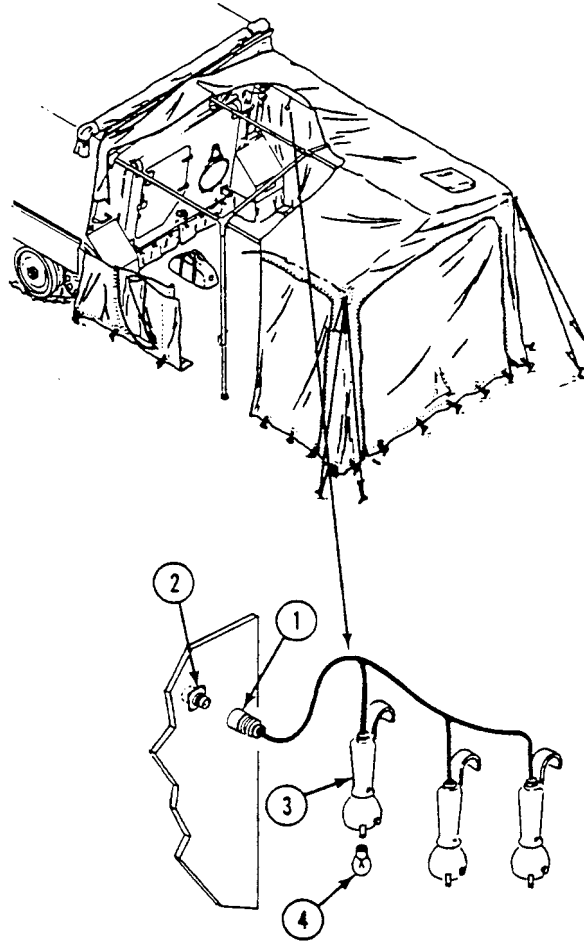
**FOLLOW-THROUGH STEPS**

1. Connect battery ground lead (WP 0338 00).
2. Turn MASTER SWITCH ON (see your -10).
3. Check that tent lamps operate properly (see your -10).
4. Turn all switches OFF (see your -10).

END OF TASK

REPLACE ENGINE OIL LOW PRESSURE TRANSMITTER AND HARDWARE

0320 00

THIS WORK PACKAGE COVERS:

Removal (page 0320 00-1).
 Installation (page 0320 00-3).

INITIAL SETUP:

Maintenance Level

Unit

References

See your -10

Tools and Special Tools

General Mechanic's Tool Kit (WP 0926 00, Item 65)

Equipment Condition

Engine stopped (see your -10)

Materials/Parts

Sealing compound (WP 0928 00, Item 56)

Locknut

Carrier blocked (see your -10)

Personnel Required

Unit Mechanic

Driver's power plant access panel removed (see your -10)

REMOVAL

1. Disconnect circuit 34 lead (1) from engine oil low pressure transmitter (2).

2. Remove locknut (3), two washers (4), screw (5), and clamp (6) securing pressure transmitter (2) to bracket (7). Discard locknut.
3. Remove pressure transmitter (2) from tee (8).
4. Disconnect hose (9) from adapter (10).
5. Remove adapter (10) from tee (8).
6. Remove tee (8) and nipple (11) from elbow (12).
7. Remove elbow (12) and reducer (13) from engine.

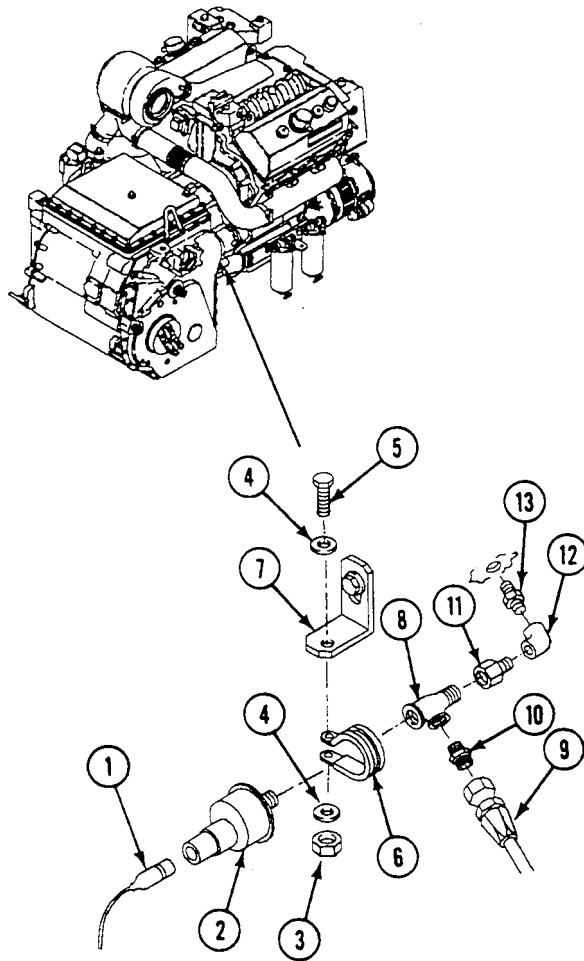

INSTALLATION**NOTE**

Coat male tapered threads with sealing compound.

1. Install reducer (1) and elbow (2) on engine.
2. Install nipple (3) and tee (4) on elbow (2).
3. Install adapter (5) in tee (4).
4. Connect hose (6) to adapter (5).
5. Install pressure transmitter (7) in tee (4).
6. Secure pressure transmitter (7) to bracket (8) with clamp (9), screw (10), two washers (11), and new locknut (12).
7. Connect circuit 34 lead (13) to pressure transmitter (7).

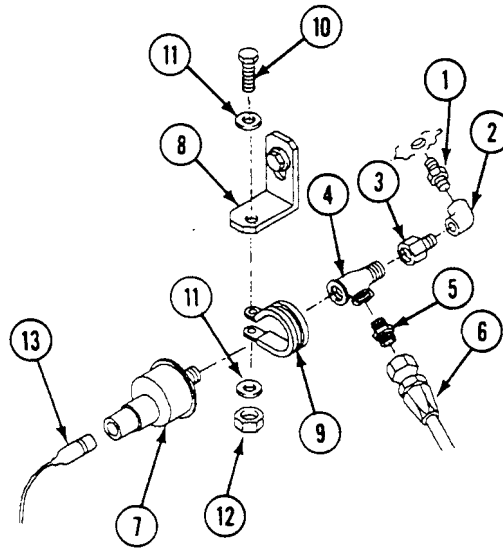
**FOLLOW-THROUGH STEPS**

1. Turn MASTER SWITCH ON (see your -10).
2. Check the ENGINE OIL LOW PRESS light is on (see your -10).
3. Start engine (see your -10). ENGINE OIL LOW PRESS light should go off.
4. Check for oil leaks at engine low oil pressure transmitter (see your -10).
5. Stop engine (see your -10).
6. Install driver's power plant access panel (see your -10).

END OF TASK

REPLACE COOLANT TEMPERATURE TRANSMITTER

0321 00

THIS WORK PACKAGE COVERS:

Removal (page 0321 00-1).
 Installation (page 0321 00-2).

INITIAL SETUP:

Maintenance Level

Unit

References

See your -10

Tools and Special Tools

General Mechanic's Tool Kit (WP 0926 00, Item 65)

Equipment Condition

Engine stopped (see your -10)
 Carrier blocked (see your -10)
 Power plant upper rear access panel removed (see your -10)
 Coolant level drained below thermostat housing (WP 0227 00)

Materials/Parts

Sealing compound (WP 0928 00, Item 56)

Personnel Required

Unit Mechanic

REMOVAL

1. Disconnect circuit 33 lead (1) from engine coolant temperature switch (2).
2. Remove switch (2) from thermostat housing (3).

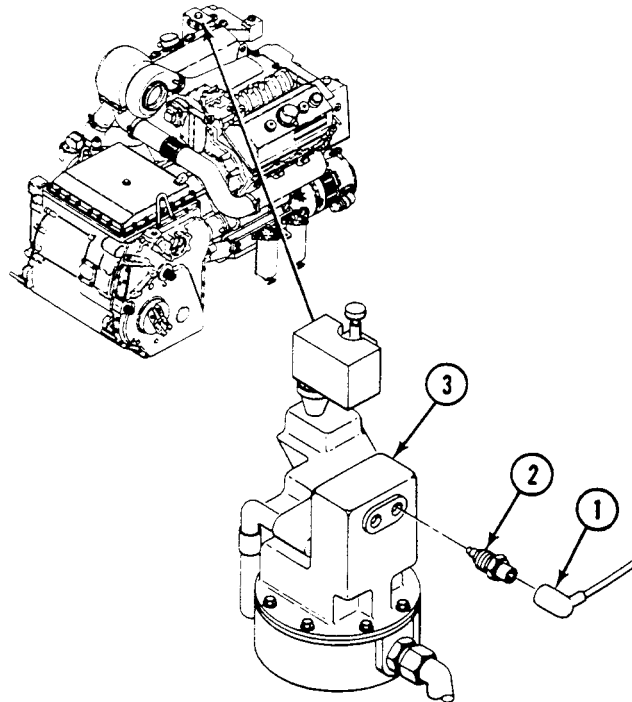

INSTALLATION

1. Coat threads of switch (2) with sealing compound.
2. Install switch (2) in thermostat housing (3).
3. Connect circuit 33 lead (1) to switch (2).

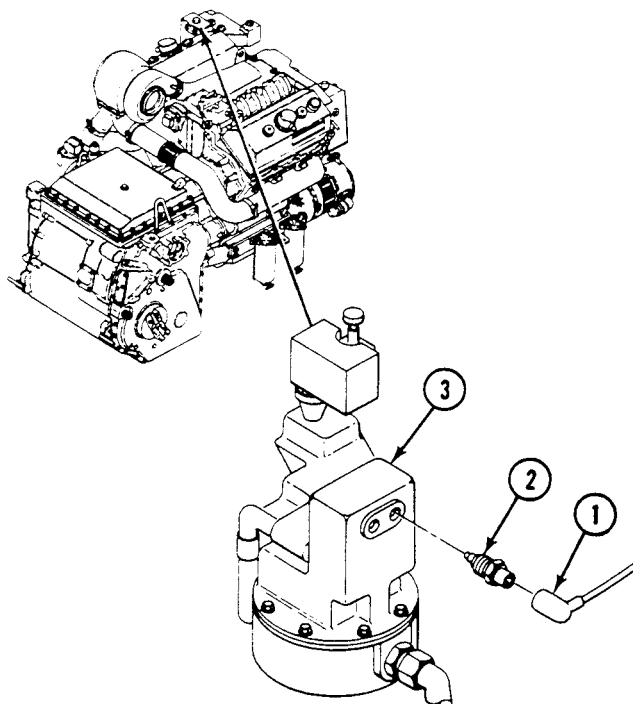
**FOLLOW-THROUGH STEPS**

1. Fill coolant system to proper level (WP 0227 00).
2. Start engine (see your -10).
3. Check for leaks (see your -10).
4. Stop engine (see your -10).
5. Install power plant upper rear access panel (see your -10).

END OF TASK

REPLACE VARIABLE SPEED FAN DRIVE SENSORS AND SWITCHES (NEW CONFIGURATION)

0321 01

THIS WORK PACKAGE COVERS:

Removal (WP 0321 00-1).

Installation (WP 0321 00-2).

INITIAL SETUP:

Maintenance Level

Unit

References

See your -10

Tools and Special Tools

General Mechanic's Tool Kit (WP 0926, Item 65)

Equipment Conditions

Engine stopped (see your -10)

Carrier blocked (see your -10)

Power plant rear access panels removed (see your -10)

Driver's power plant access panel removed (see your -10)

Battery ground strap disconnected (WP 0334 00 or

WP 0338 00)

Materials/Parts

Tiedown straps

Personnel Required

Unit Mechanic

REMOVAL

NOTE

Install covers on disconnected electrical component cable connections during maintenance. Use any appropriate material to prevent damage to components.

Mark and tag all connections prior to disconnection.

1. Disconnect variable speed wiring harness plug P3 (1) from engine running switch S2 (2).
2. Remove engine running switch S2 (2) from tee (3) on secondary fuel filter (4).
3. Disconnect variable speed wiring harness plug P6 (5) from engine coolant sensor 3A3 (6). Remove engine coolant sensor 3A3 (6).

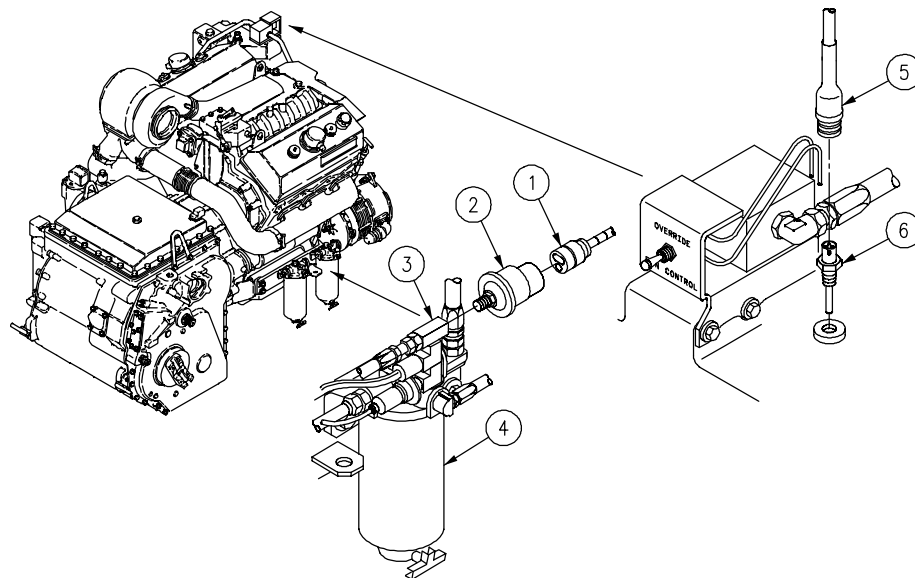

INSTALLATION

1. Install engine coolant sensor 3A3 (6). Connect variable speed wiring harness plug P6 (5) on engine coolant sensor 3A3 (6).
2. Install engine running switch S2 (2) to tee on secondary fuel filter (4). Connect variable speed wiring harness plug P3 (1) on engine running switch S2 (2).

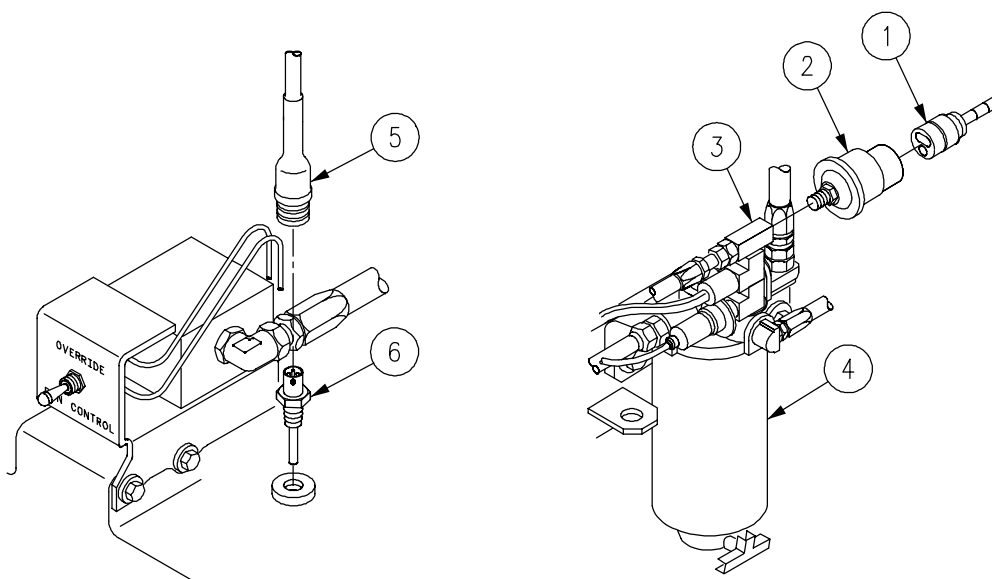
**FOLLOW-THROUGH STEPS**

1. Connect battery ground strap (WP 0334 00 or WP 0338 00).
2. Install driver's power plant access panel (see your-10).
3. Install power plant rear access panels (see your-10).

END OF TASK

REPLACE TRANSMISSION OIL HIGH TEMPERATURE SWITCH

0322 00

THIS WORK PACKAGE COVERS:

Removal (page 0322 00-1).
 Installation (page 0322 00-2).

INITIAL SETUP:

Maintenance Level

Unit

Personnel Required

Unit Mechanic

Tools and Special Tools

General Mechanic's Tool Kit (WP 0926 00, Item 65)

References

See your -10

Materials/Parts

Sealing compound (WP 0928 00, Item 56)
 Thermostatic switch

Equipment Condition

Power plant removed (WP 0156 00)

REMOVAL

1. Disconnect circuit 327 lead (1) from switch (2).
2. Remove switch (2) from tee (3).

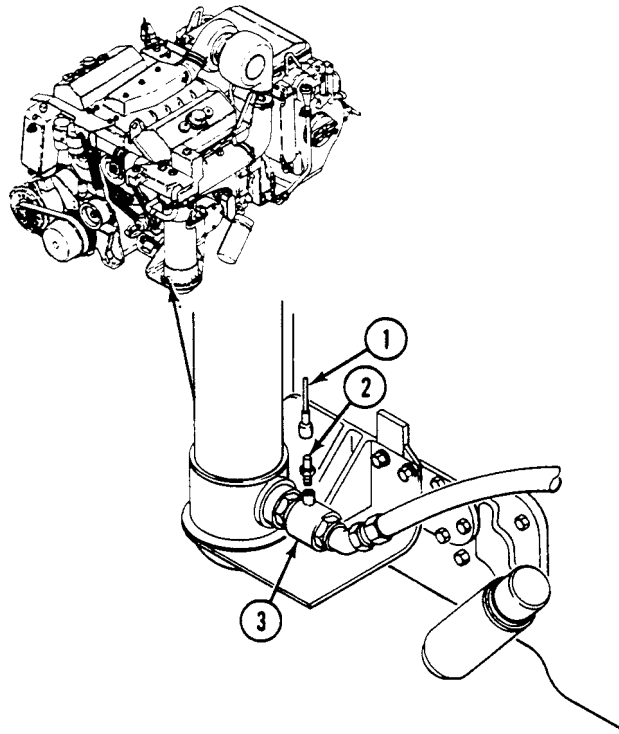

INSTALLATION

1. Apply sealing compound to threads of switch (2).
2. Install switch (2) in tee (3).
3. Connect circuit 327 lead (1) to switch (2).

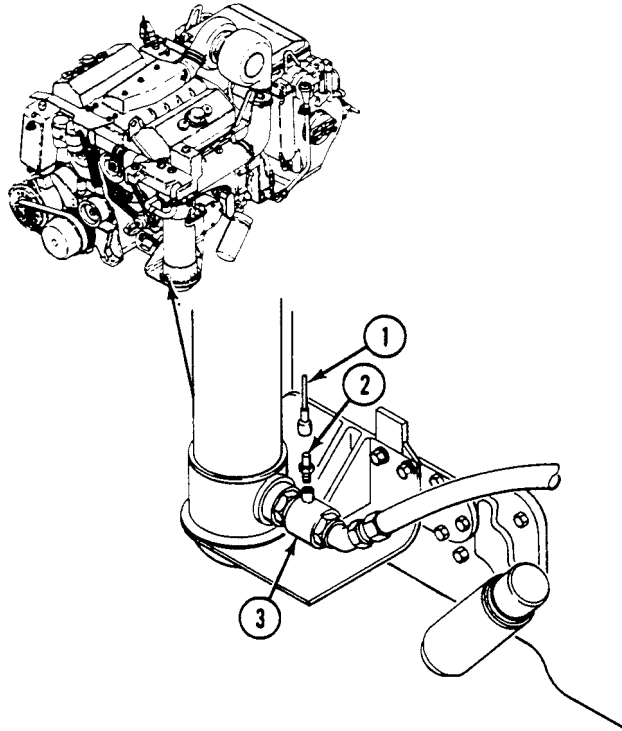
**FOLLOW-THROUGH STEPS**

1. Install power plant (WP 0156 00).

END OF TASK

REPLACE GENERATOR FIELD PRESSURE SWITCH

0323 00

THIS WORK PACKAGE COVERS:

- Removal (page 0323 00-1)
- Inspection and Repair (page 0323 00-1)
- Installation (page 0323 00-2)

INITIAL SETUP:

Maintenance Level

Unit

References

See your -10

Tools and Special Tools

General Mechanic's Tool Kit (WP 0926 00, Item 65)

Equipment Condition

- Engine stopped (see your -10)
- Carrier blocked (see your -10)
- Driver's power plant access panel removed (see your -10)

Materials/Parts

Sealing compound (WP 0928 00, Item 56)

Personnel Required

Unit Mechanic

REMOVAL

1. Disconnect circuit 1A/1B lead (1) from generator field switch (2).
2. Remove switch (2) from tee (3) on secondary fuel filter (4).
3. Check circuit lead. Replace worn or cracked lead and damaged connector (WP 0382 00).

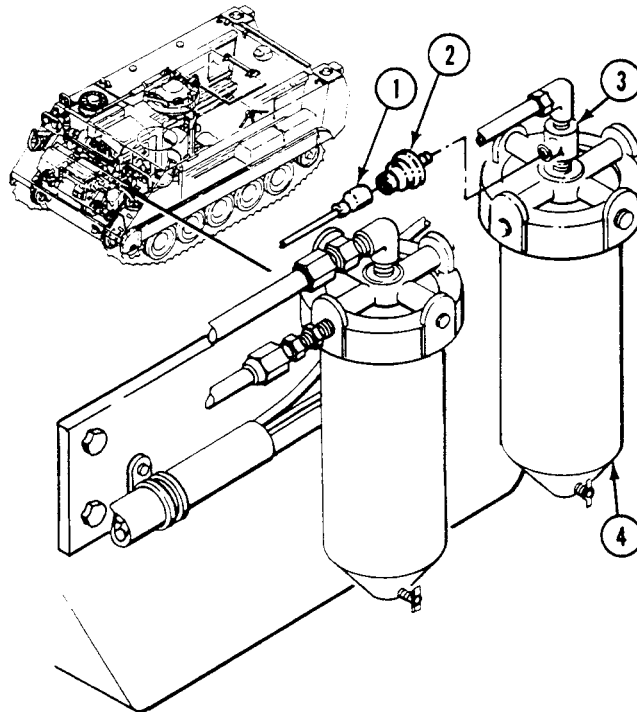

INSPECTION-ACCEPTANCE AND REJECTION CRITERIA

1. Check circuit lead. Replace worn or cracked lead and damaged connector WP 0382 00

INSTALLATION

1. Coat threads of switch with sealing compound.
2. Install switch (2) on tee (3) on secondary fuel filter (4).
3. Connect circuit 1A/1B lead (1) to switch (2).

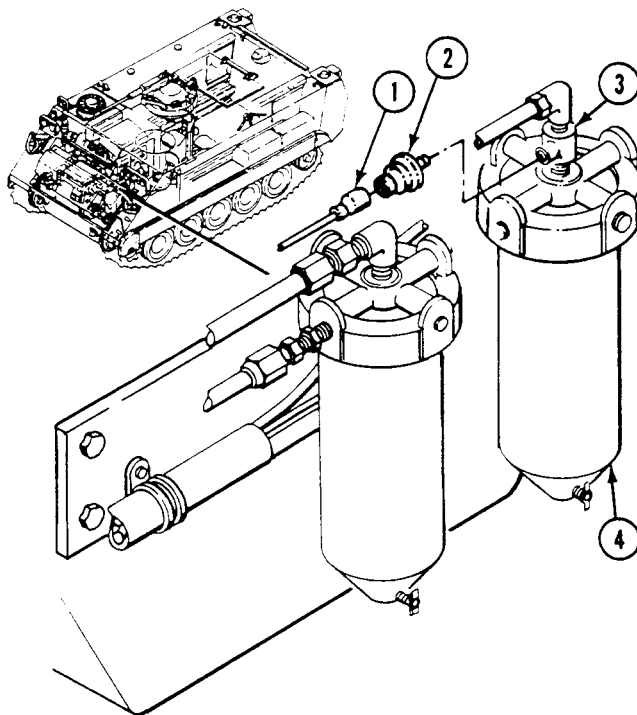
**FOLLOW-THROUGH STEPS**

1. Check operation of field switch (WP 0025 00).
2. Install driver's power plant access panel (see your -10).

END OF TASK

REPLACE FUEL SUPPLY PRESSURE TRANSDUCER

0324 00

THIS WORK PACKAGE COVERS:

- Removal (page 0324 00-1).
- Installation (page 0324 00-2).

INITIAL SETUP:

Maintenance Level

Unit

References

See your -10

Tools and Special Tools

General Mechanic's Tool Kit (WP 0926 00, Item 65)

Equipment Condition

Engine stopped (see your -10)

Carrier blocked (see your -10)

Materials/Parts

Adhesive (WP 0928 00, Item 4)

Driver's compartment access panel removed (see your -10)

Personnel Required

Unit Mechanic

REMOVAL

1. Disconnect fuel supply pressure transducer lead (1) from wiring harness (2).
2. Remove transducer (3) from fitting (4).

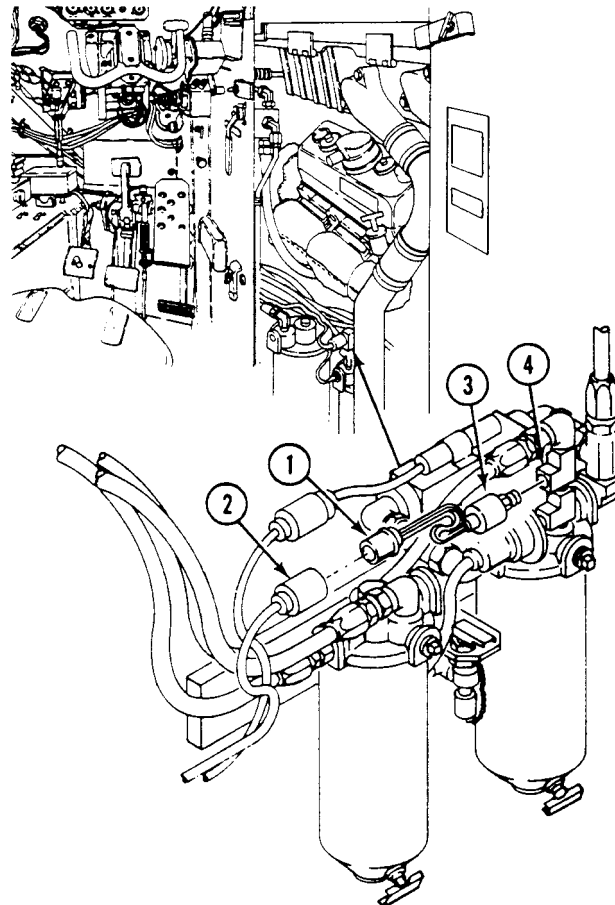

INSTALLATION

1. Apply a thin coat of adhesive to threads of transducer (3).
2. Install transducer (3) on fitting (4).
3. Connect fuel supply pressure transducer lead (1) to wiring harness (2).

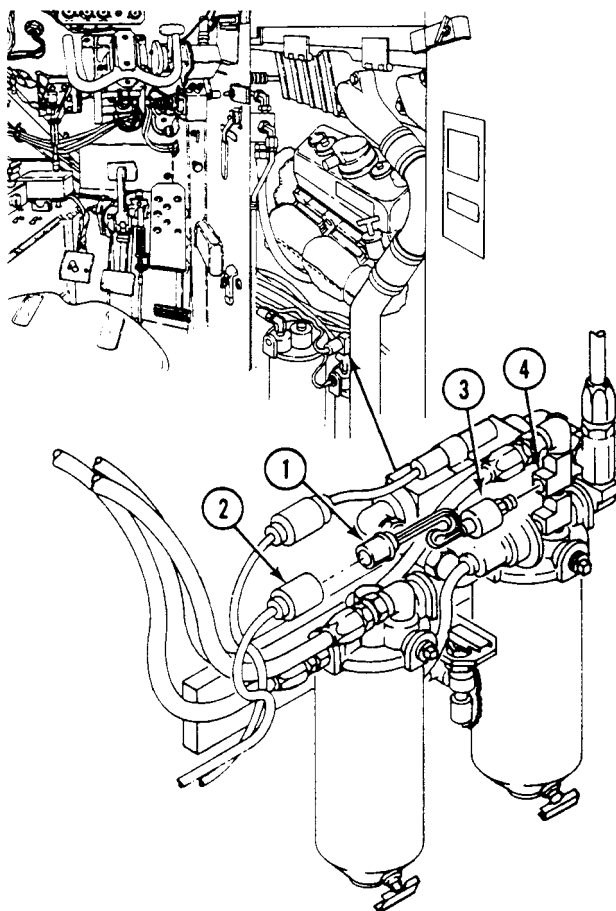
**FOLLOW-THROUGH STEPS**

1. Install driver's compartment access panel (see your -10).

END OF TASK

REPLACE FUEL RETURN PRESSURE TRANSDUCER

0325 00

THIS WORK PACKAGE COVERS:

Removal (page 0325 00-1).
 Installation (page 0325 00-2).

INITIAL SETUP:

Maintenance Level

Unit

References

See your -10

Tools and Special Tools

General Mechanic's Tool Kit (WP 0926 00, Item 65)

Equipment Condition

Engine stopped (see your -10)
 Carrier blocked (see your -10)
 Trim vane lowered (see your -10)
 Power plant front access door opened (see your -10)
 Air cleaner removed (WP 0168 00)
 Power plant grill raised (WP 0464 00)

Materials/Parts

Adhesive (WP 0928 00, Item 4)

Personnel Required

Unit Mechanic

REMOVAL

1. Disconnect fuel return pressure transducer lead (1) from STE/ICE wiring harness (2).
2. Disconnect transducer (3) from tee (4).

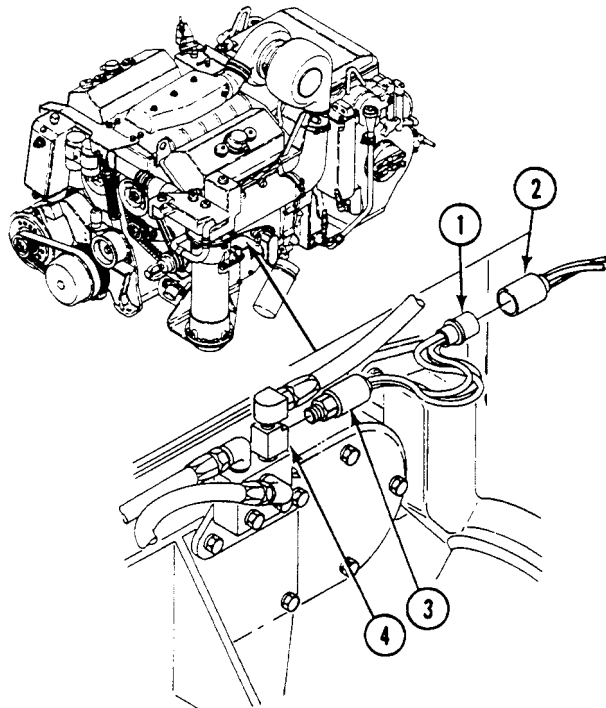

INSTALLATION

1. Apply a thin coat of adhesive to threads of transducer (3).
2. Connect transducer (3) to tee (4).
3. Connect fuel return pressure transducer lead (1) to STE/ICE wiring harness (2).

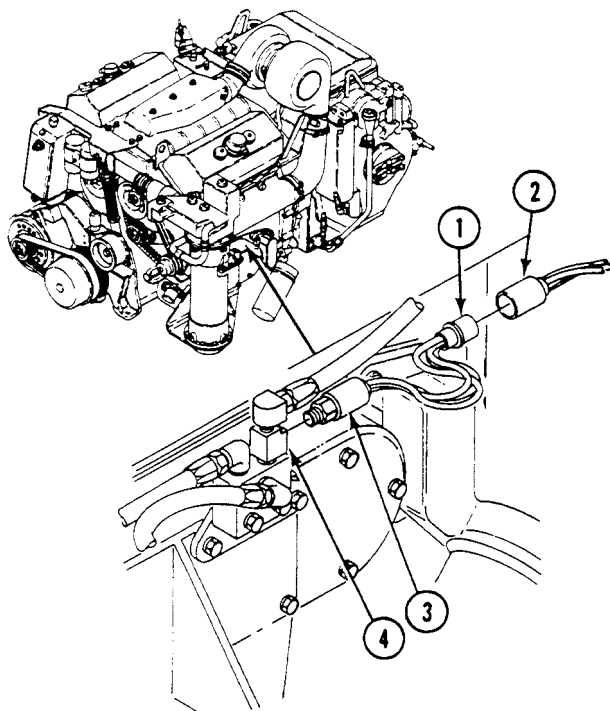
**FOLLOW-THROUGH STEPS**

1. Lower power plant grill (WP 0464 00).
2. Install air cleaner (WP 0168 00).
3. Close power plant front access door (see your -10).
4. Raise trim vane (see your -10).

END OF TASK

REPLACE TURBO OUTLET PRESSURE TRANSDUCER

0326 00

THIS WORK PACKAGE COVERS:

Removal (page 0326 00-1).
 Installation (page 0326 00-2).

INITIAL SETUP:

Maintenance Level

Unit

References

See your -10

Tools and Special Tools

General Mechanic's Tool Kit (WP 0926 00, Item 65)

Equipment Condition

Engine stopped (see your -10)
 Carrier blocked (see your -10)
 Power plant upper rear access panel removed (see your -10)

Materials/Parts

Adhesive (WP 0928 00, Item 4)

Personnel Required

Unit Mechanic

REMOVAL

1. Disconnect transducer lead (1) from wiring harness (2).
2. Disconnect transducer (3) from turbo outlet housing (4).

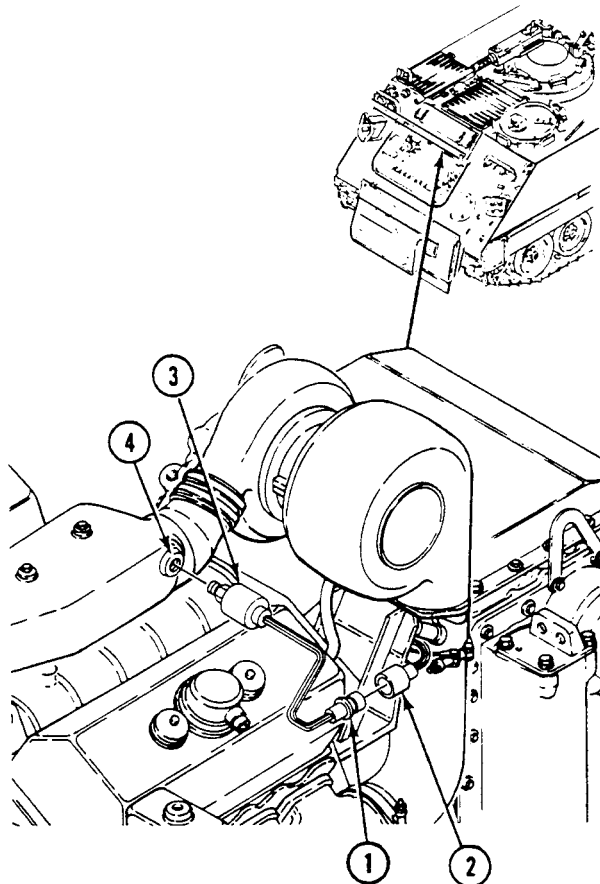

INSTALLATION

1. Apply a thin coat of adhesive to external threads of transducer (3).
2. Connect transducer (3) to turbo outlet housing (4).
3. Connect transducer lead (1) to wiring harness (2).

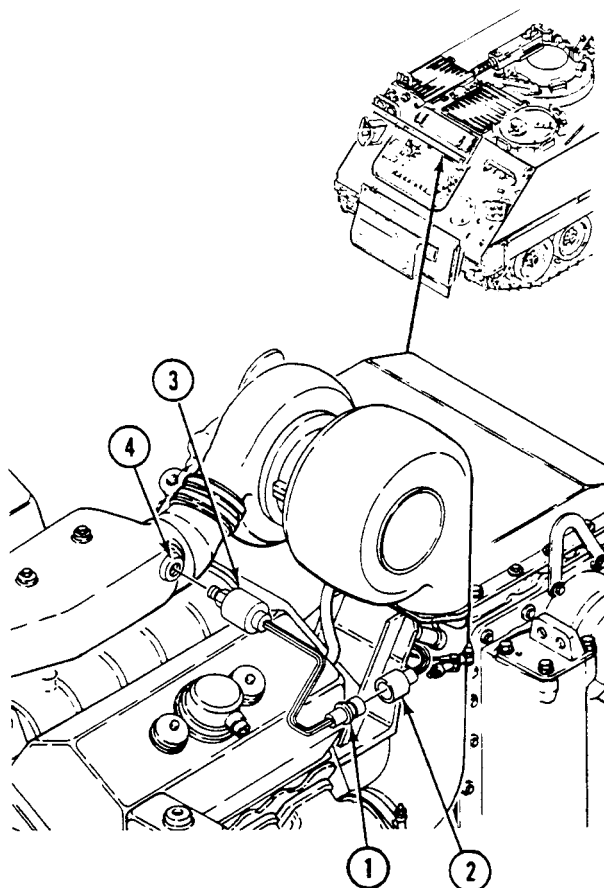
**FOLLOW-THROUGH STEPS**

1. Install power plant rear access panel (see your -10).

END OF TASK

REPLACE AIR BOX PRESSURE TRANSDUCER

0327 00

THIS WORK PACKAGE COVERS:

Removal (page 0327 00-1).
 Installation (page 0327 00-2).

INITIAL SETUP:

Maintenance Level

Unit

References

See your -10

Tools and Special Tools

General Mechanic's Tool Kit (WP 0926 00, Item 65)

Equipment Condition

Engine stopped (see your -10)

Materials/Parts

Adhesive (WP 0928 00, Item 4)

Carrier blocked (see your -10)

Personnel Required

Unit Mechanic

Driver's compartment access panel removed (see your -10)

REMOVAL

1. Disconnect air box pressure transducer lead (1) from STE/ICE wiring harness (2).
2. Disconnect transducer (3) from housing (4).

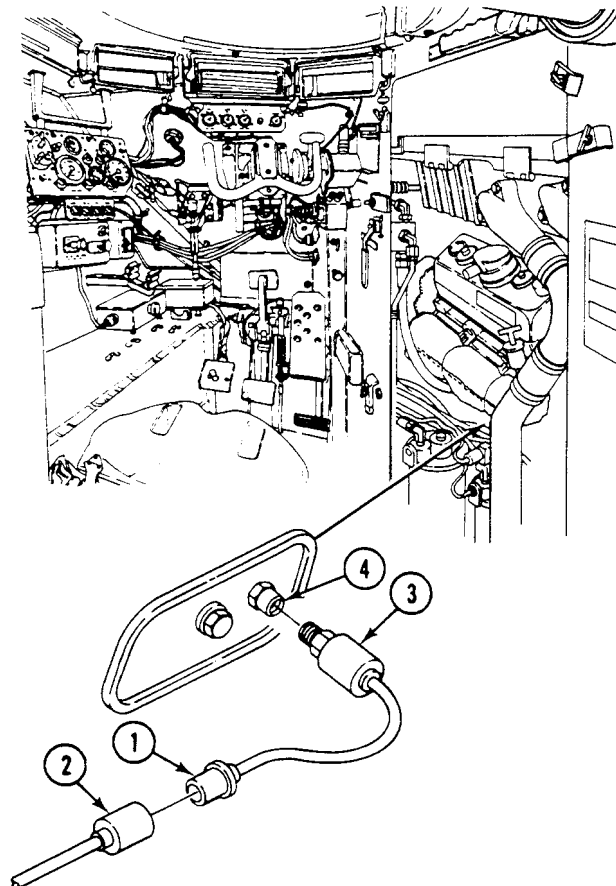

INSTALLATION

1. Apply a thin coat of adhesive to threads of transducer (3).
2. Connect transducer (3) to housing (4).
3. Connect air box pressure transducer lead (1) to STE/ICE wiring harness (2).

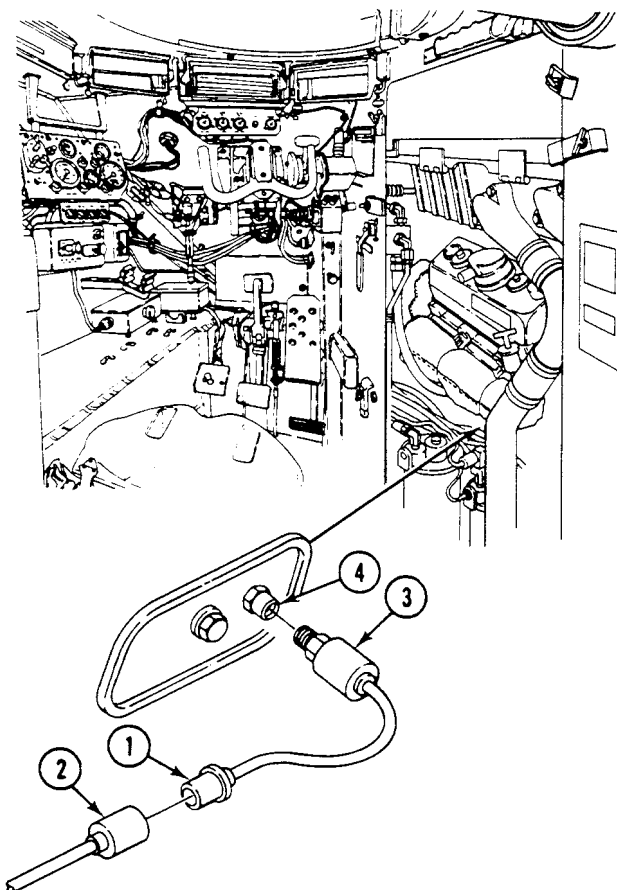
**FOLLOW-THROUGH STEPS**

1. Install driver's compartment access panel (see your -10).

END OF TASK

REPLACE FUEL FILTER DIFFERENTIAL PRESSURE SWITCH

0328 00

THIS WORK PACKAGE COVERS:

Removal (page 0328 00-1).
 Installation (page 0328 00-5).

INITIAL SETUP:

Maintenance Level

Unit

References

See your -10

Tools and Special Tools

General Mechanic's Tool Kit (WP 0926 00, Item 65)
 Suitable container
 Machinist's vise (WP 0926 00, Item 68)

Equipment Condition

Engine stopped (see your -10)
 Carrier blocked (see your -10)
 Battery ground strap disconnected (WP 0337 00),
 (WP 0338 00), (WP 0339 00)
 Power plant upper rear access panel removed (see your
 -10)
 Driver's compartment access panel removed (see your
 -10)

Materials/Parts

Adhesive (WP 0928 00, Item 4)
 Gasket
 Locknut (2)
 Lockwasher (2)

Personnel Required

Unit Mechanic

REMOVAL

1. Disconnect fuel supply hose (1) at quick-disconnect fitting (2).
2. Disconnect fuel return hose (3) at quick-disconnect fitting (4).

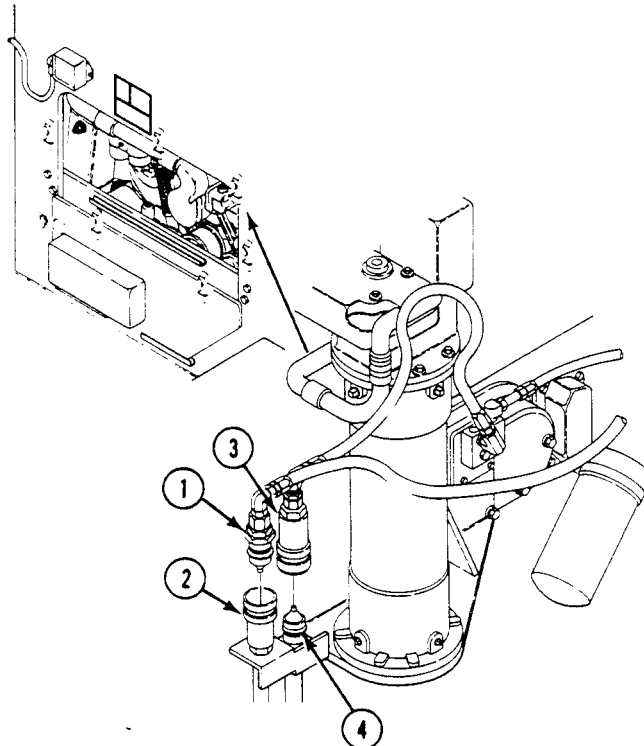

3. Disconnect fuel pressure transducer lead (5) from wiring harness (6).
4. Disconnect differential pressure switch lead (7) from wiring harness (8).

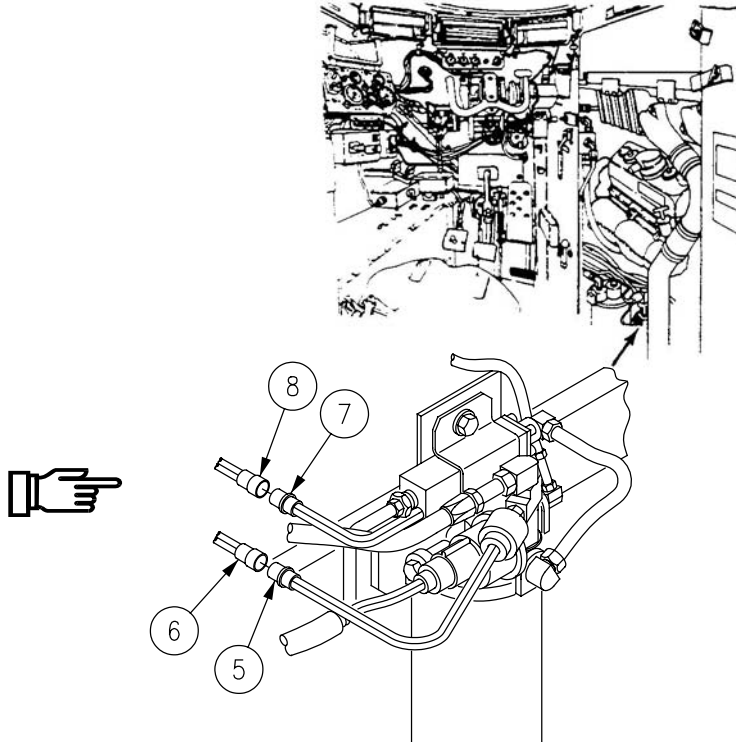

NOTE

Transducer removed from art view for clarity in removing field switch (2).

5. Disconnect field switch lead (1) from field switch (2). Remove field switch from elbow (3).
6. Remove fuel tube (4) from filter inlet elbow (5) and filter differential pressure switch elbow (6).

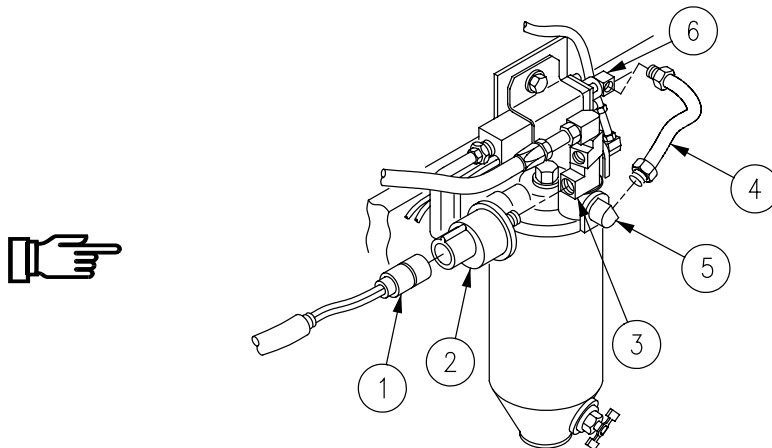

REPLACE FUEL FILTER DIFFERENTIAL PRESSURE SWITCH — Continued

0328 00

7. Disconnect hose (7) from fuel filter outlet elbow (8).
8. Disconnect hose (9) from fuel filter elbow (10).

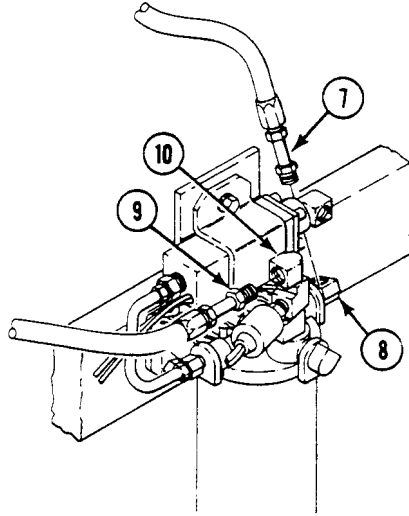

9. Remove tube (11) from fuel filter outlet adapter (12) and filter differential pressure switch adapter (13).

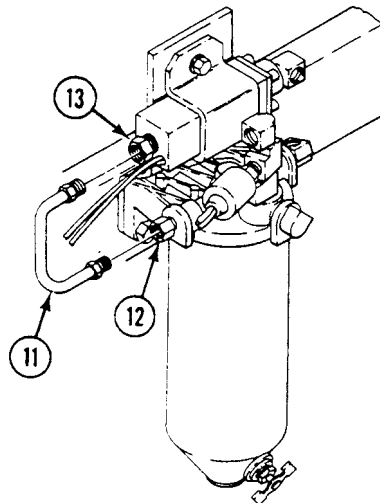

10. Place container under drain cock (14). Open drain cock and drain fuel. Close drain cock.
11. Hold filter canister (15). Loosen screw (16). Remove canister and filter element (17) from filter head (18).
12. Remove gasket (19) from filter head (18). Discard gasket.

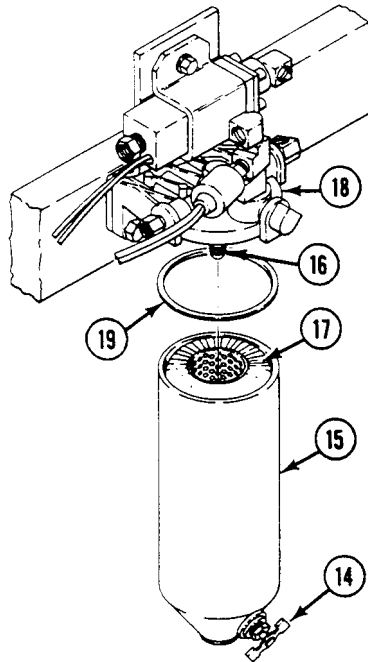

13. Remove two screws (1), four washers (2), two locknuts (3), filter head (4) and differential pressure switch bracket (5) from engine. Discard locknuts.

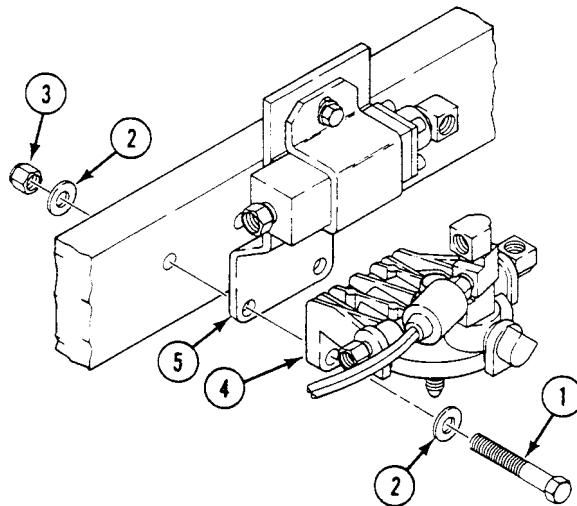

14. Clamp differential pressure switch bracket (5) in vise. Remove adapter (6) and elbow (7) from pressure switch (8).
15. Remove two screws (9), lockwashers (10), support (11) and differential pressure switch (8) from bracket (5). Discard lockwashers.

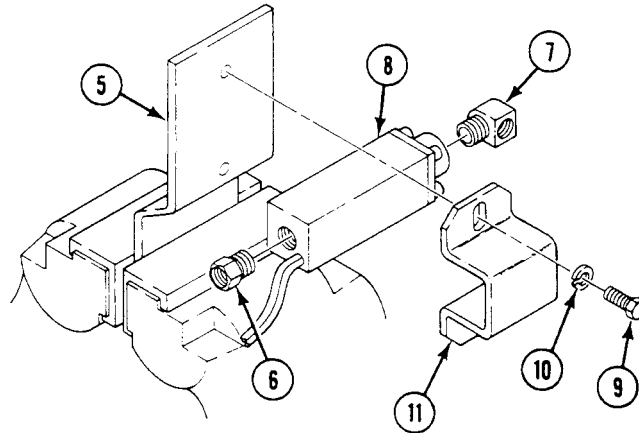

INSTALLATION

1. Clamp bracket (5) in vise. Install differential pressure switch (8) and support (11) on bracket. Secure with two screws (9) and new lockwashers (10).
2. Apply a thin coat of adhesive to external threads of fittings.
3. Install adapter (6) and elbow (7) on differential pressure switch (8).

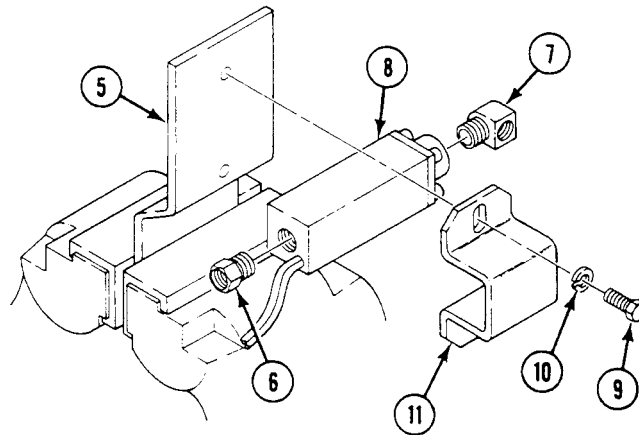

REPLACE FUEL FILTER DIFFERENTIAL PRESSURE SWITCH — Continued**0328 00**

4. Install switch bracket (5) and filter head (4) on engine. Secure with two screws (1), four washers (2), and two new locknuts (3).

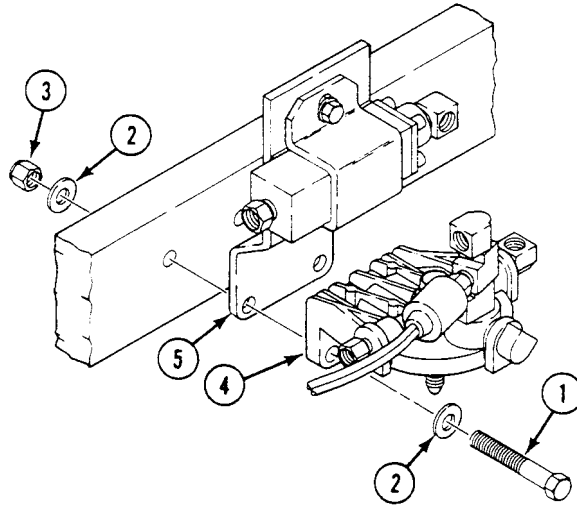

5. Install new gasket (1) on filter head (2).
6. Install filter canister (3) with filter element (4) on filter head (2). Tighten screw (5).

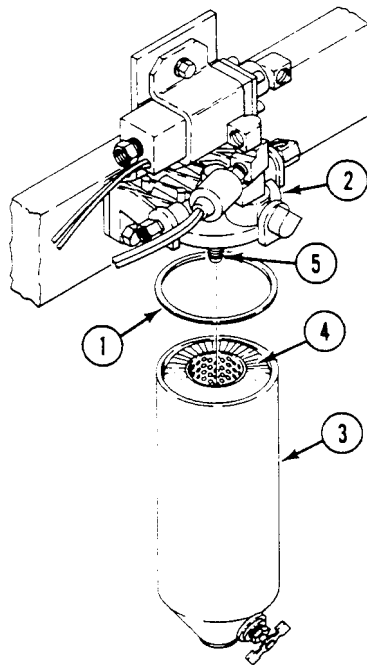

7. Install tube (6) on fuel filter outlet adapter (7) and filter differential pressure switch adapter (8).

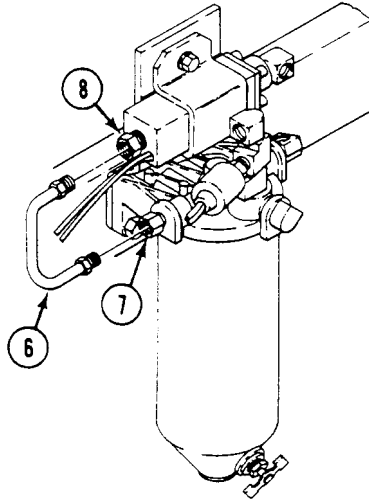

8. Connect hose (9) to fuel filter elbow (10).
9. Connect hose (11) to fuel filter outlet elbow (12).

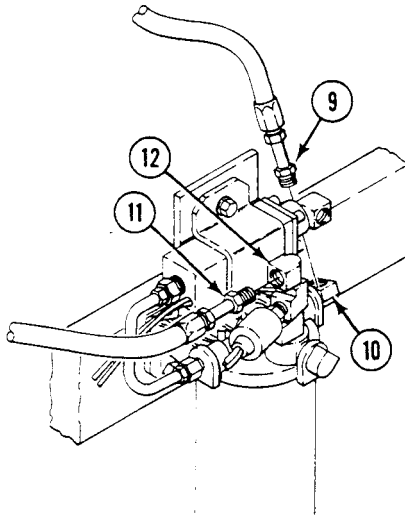

10. Install tube (13) on filter inlet elbow (14) and filter differential pressure switch elbow (15).
11. Apply a thin coat of adhesive to external threads of field switch (16).

NOTE

Transducer removed from art view for clarity in installing field switch (16).

12. Install field switch (16) on elbow (17). Connect lead (18) to field switch.

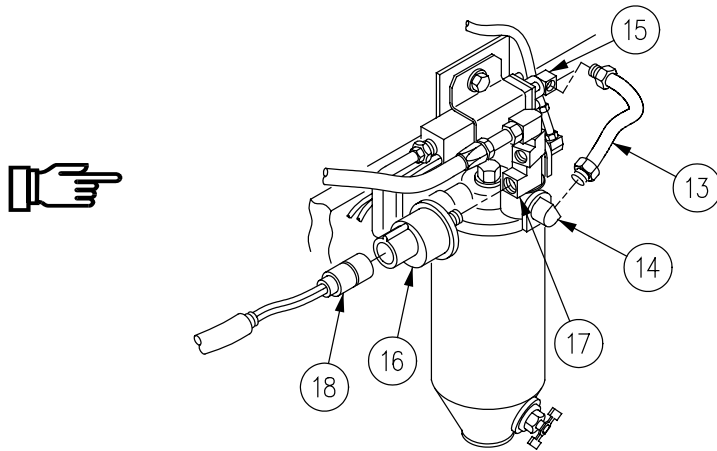

13. Connect differential pressure switch lead (1) to wiring harness (2).
14. Connect fuel pressure transducer lead (3) to wiring harness (4).

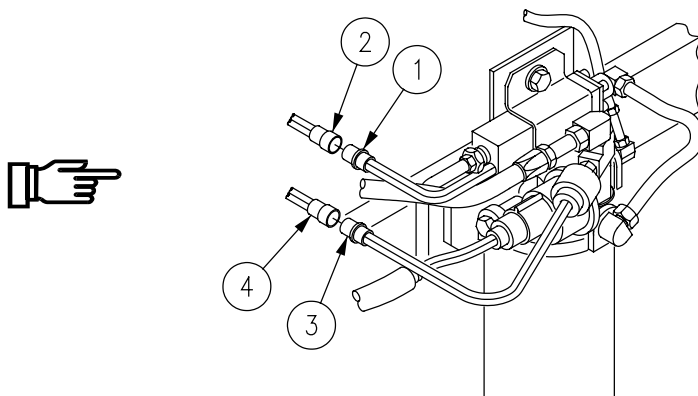

15. Connect fuel supply hose (5) at quick-disconnect fitting (6).
16. Connect fuel return hose (7) at quick-disconnect fitting (8).

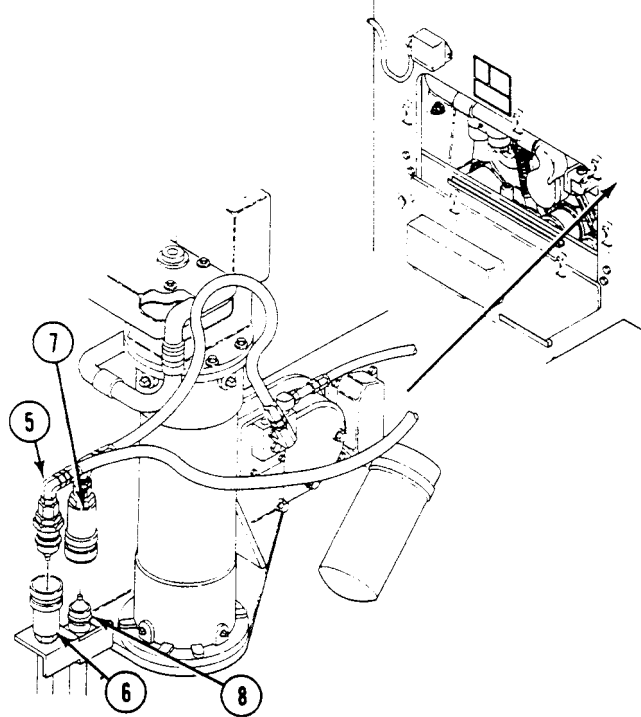
**FOLLOW-THROUGH STEPS**

1. Install driver's compartment access panel (see your -10).
2. Install power plant upper rear access panel (see your -10).
3. Connect battery ground strap (WP 0337 00), (WP 0338 00), (WP 0339 00).

END OF TASK

REPLACE AUXILIARY TANK FLUID LEVEL DETECTOR

0329 00

THIS WORK PACKAGE COVERS:

Removal (page 0329 00-1).
 Installation (page 0329 00-2).

INITIAL SETUP:

Maintenance Level

Unit

References

See your -10

Tools and Special Tools

General Mechanic's Tool Kit (WP 0926 00, Item 65)

Equipment Condition

Engine stopped (see your -10)
 Carrier blocked (see your -10)
 Power plant upper rear access panel removed (see your -10)
 Cooling system drained until auxiliary tank empty (WP 0227 00)

Materials/Parts

Sealing compound (WP 0928 00, Item 56)

Personnel Required

Unit Mechanic

REMOVAL

1. Disconnect detector cable (1) from connector (2).

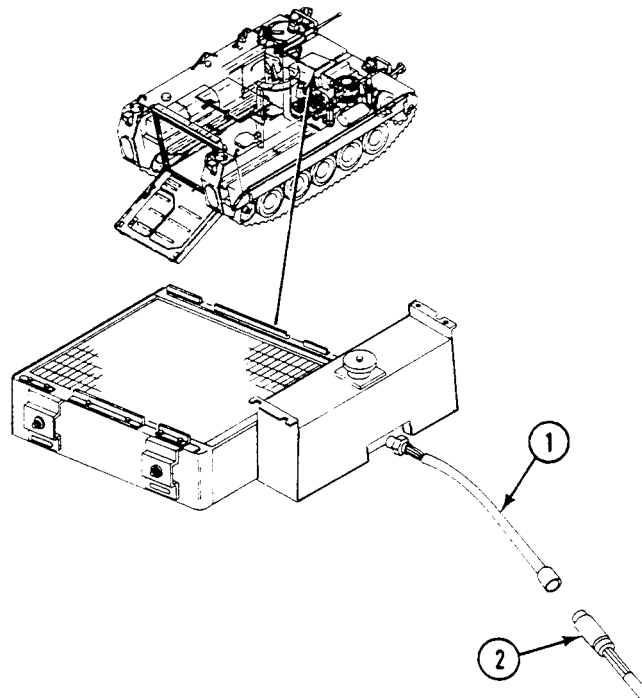

2. Remove detector (3) from auxiliary tank (4).

INSTALLATION

1. Apply sealing compound to threads of detector (3).
2. Install detector (3) on auxiliary tank (4).

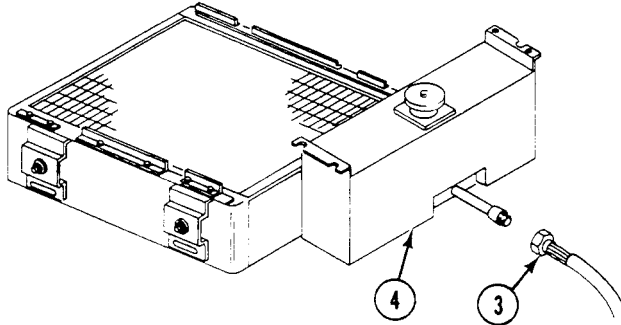

3. Connect detector cable (1) to connector (2).

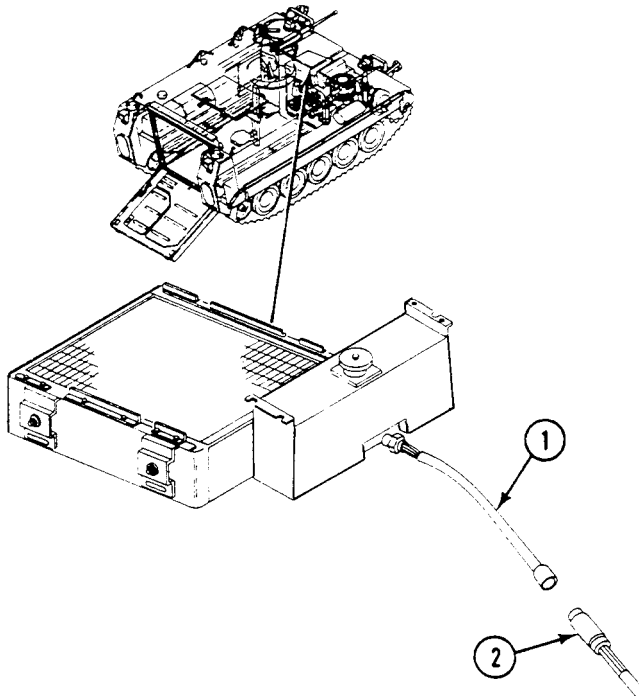

FOLLOW-THROUGH STEPS

1. Fill cooling system (WP 0227 00).
2. Install power plant upper rear access panel (see your -10).

END OF TASK

REPLACE STEERING LOCK SWITCH

0330 00

THIS WORK PACKAGE COVERS:

Removal (page 0330 00-2).
 Installation (page 0330 00-3).

INITIAL SETUP:

Maintenance Level

Unit

References

See your -10

Tools and Special Tools

General Mechanic's Tool Kit (WP 0926 00, Item 65)

Equipment Condition

Engine stopped (see your -10)

Carrier blocked (see your -10)

Materials/Parts

Tiedown strap

Solenoid bracket removed (WP 0428 00) or control
 assembly bracket removed (WP 0429 00)

Personnel Required

Unit Mechanic

REMOVAL

1. Disconnect leads 369 and 369A (used on solenoid-activated lock) or leads 368 and 369A (used on cable-activated lock) (1) and (2) from switch leads (3) and (4). Cut and remove tiedown strap (5). Discard strap.
2. Remove grommet (6) with leads (3) and (4) from bracket (7).
3. Loosen jamnut (8). Remove jamnut by hand, and remove switch (9) from bracket (7).

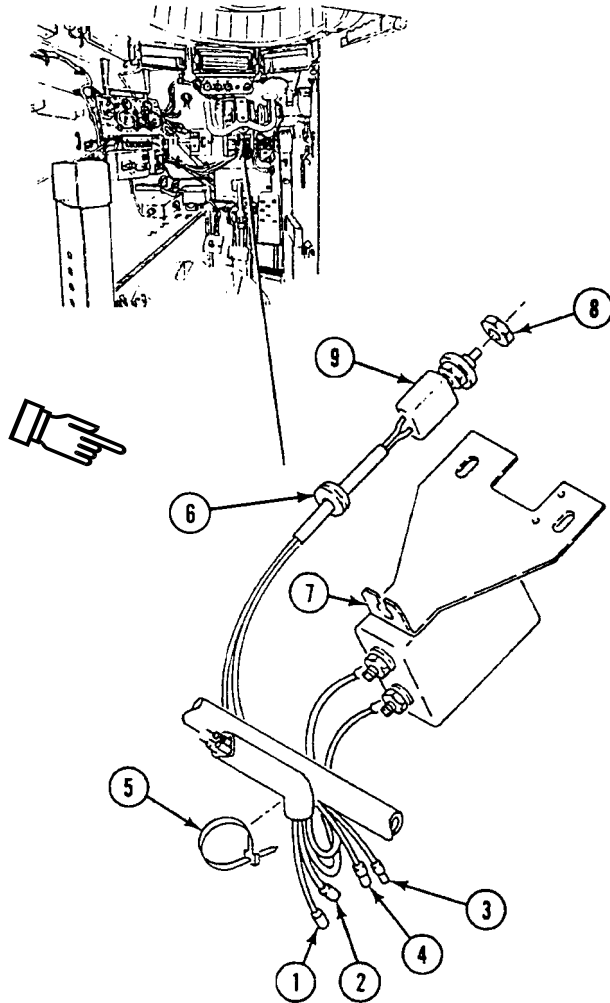

INSTALLATION

1. Remove forward jamnut (8) on new switch (9) by hand. Do not remove rear jamnut, lockwasher, and keyway washer.
2. Install switch (9) into bracket (7), running jamnut down to bracket.
3. Adjust switch (9) so plunger is fully depressed when steering is unlocked (transmission controller in any position except SL). Tighten jamnuts (8) on switch.
4. Install switch leads (3) and (4) with grommet (6) on bracket (7).
5. Connect leads 369 and 369A (used on solenoid-activated lock) or leads 368 and 369A (used on cable-activated lock) (1) and (2) to switch leads (3) and (4). Secure with new tiedown strap (5).

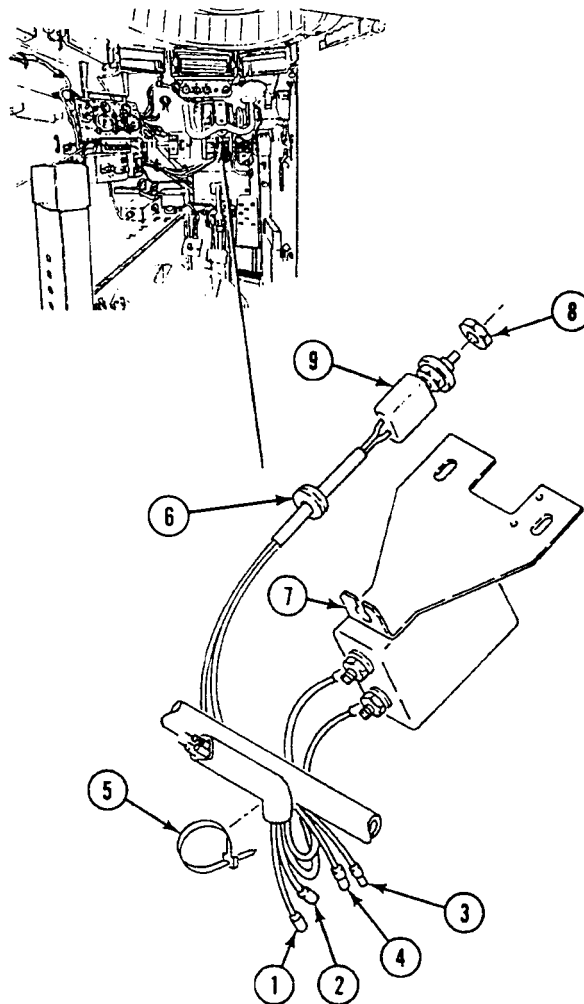
**FOLLOW-THROUGH STEPS**

1. Install solenoid bracket (WP 0428 00) or control assembly bracket (WP 0429 00).

END OF TASK

REPLACE PARKING BRAKE SWITCH/BRACKET

0331 00

THIS WORK PACKAGE COVERS:

- Removal (page 0331 00-1).
- Cleaning and inspection (page 0331 00-3).
- Installation (page 0331 00-3).
- Adjustment (page 0331 00-4).

INITIAL SETUP:

Maintenance Level

Unit

Personnel Required

Unit Mechanic

Tools and Special Tools

- General Mechanic's Tool Kit (WP 0926 00, Item 65)
- Multimeter (WP 0926 00, Item 30)

References

See your -10

Materials/Parts

- Cleaning compound (WP 0928 00, Item 19)
- Wiping rag (WP 0928 00, Item 65)
- Locknut (1 or 2)

Equipment Condition

- Engine stopped (see your -10)
 - Carrier blocked (see your -10)
 - Battery ground strap disconnected (WP 0337 00), (WP 0338 00), or (WP 0339 00)
-

REMOVAL

1. Remove screw (1), two washers (2), locknut (3), and switch ground lead (4) from bracket (5). Discard locknut.

2. Disconnect three plugs (6) on switch (7) from wiring harness (8) leads 366A, 367, and 370.
3. Remove jamnut (9) and lockwasher (10) from switch (7). Remove switch from bracket (5).

NOTE

Do Step 4 if bracket needs to be removed.

4. Remove other screw (1), two washers (2), and locknut (3) that secure bracket (5) to hull. Remove bracket from hull. Discard locknut.

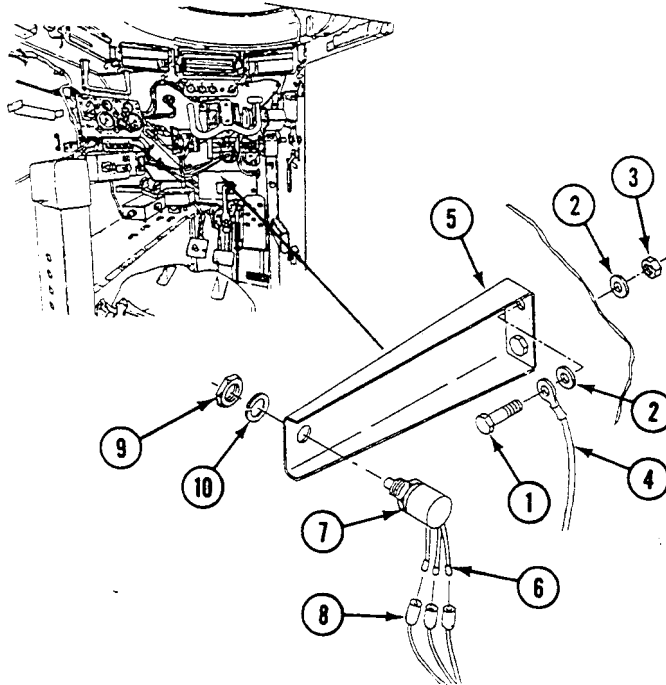

CLEANING**CLEANING AND INSPECTION**

1. Clean switch with dry rag.
2. Clean switch with cleaning compound.
3. Check circuit 370 lead and ground lead for continuity with switch plunger depressed. If test indicates open circuit, replace defective switch.
4. Check circuit 367 lead and 366A lead for continuity with switch plunger released. If test indicates open circuit, replace defective switch.

INSTALLATION**NOTE**

Do Step 1 if bracket was removed.

1. Install bracket (1) on hull. Secure with one screw (2), two washers (3), and new locknut (4). Tighten screw.
2. Install switch (5) on bracket (1). Secure with lockwasher (6) and jamnut (7). Do not tighten nut.
3. Connect three plugs (8) on switch (5) to wiring harness (9) leads 366A, 367, and 370. Make sure lead numbers match.
4. Install switch ground lead (10) on bracket (1). Secure with other screw (2), two washers (3), and new locknut (4). Tighten screw.

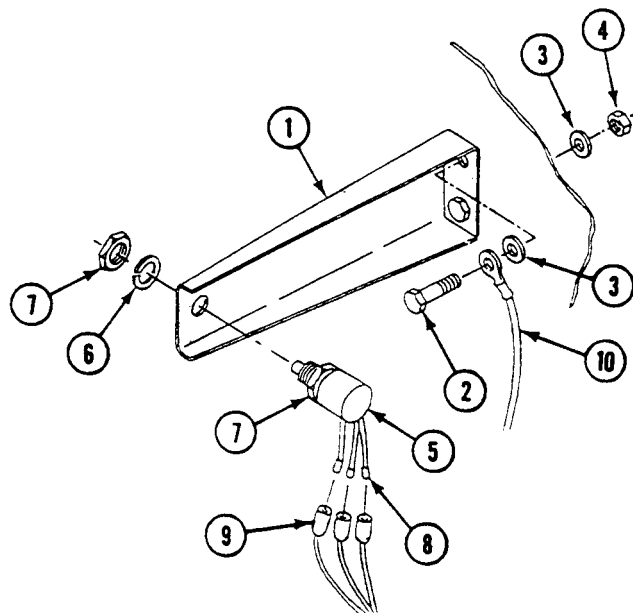

ADJUSTMENT

1. Position parking brake (11) on. Adjust jamnuts (7) until switch plunger (12) is fully depressed. Tighten jamnuts.

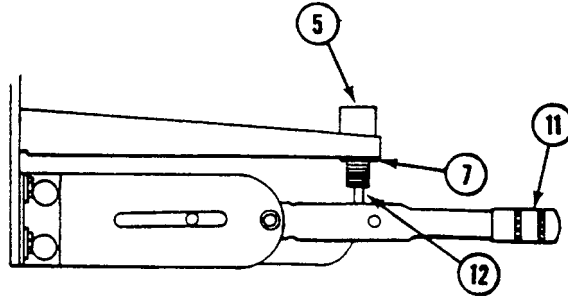
**FOLLOW-THROUGH STEPS**

1. Connect battery ground strap (WP 0337 00), (WP 0338 00), or (WP 0339 00).
2. Turn MASTER SWITCH to ON (see your -10).
3. With parking brake handle pulled, PARKING BRAKE indicator light should be on (see your -10).
4. Release parking brake handle. PARKING BRAKE indicator light should go off (see your -10).
5. Turn MASTER SWITCH to OFF (see your -10).
6. Reset parking brake handle (see your -10).

END OF TASK

REPLACE STOP SWITCH

0332 00

THIS WORK PACKAGE COVERS:

- Removal (page 0332 00-1).
- Cleaning and Inspection (page 0332 00-1).
- Installation (page 0332 00-2).

INITIAL SETUP:

Maintenance Level

Unit

Personnel Required

Unit Mechanic

Tools and Special Tools

- General Mechanic's Tool Kit (WP 0926 00, Item 65)
- Multimeter (WP 0926 00, Item 30)

References

See your -10

Materials/Parts

- Cleaning compound (WP 0928 00, Item 19)

Equipment Condition

- Engine stopped (see your -10)
- Carrier blocked (see your -10)

REMOVAL

NOTE

Tag all leads before removal.

1. Disconnect circuit 75A lead (1), circuit 75B lead (2), circuit 366 lead (3), and circuit 366A lead (4) from stop switch (5). Remove leads from switch.
2. Remove jamnut (6), two washers (7), and switch (5) from bracket (8).

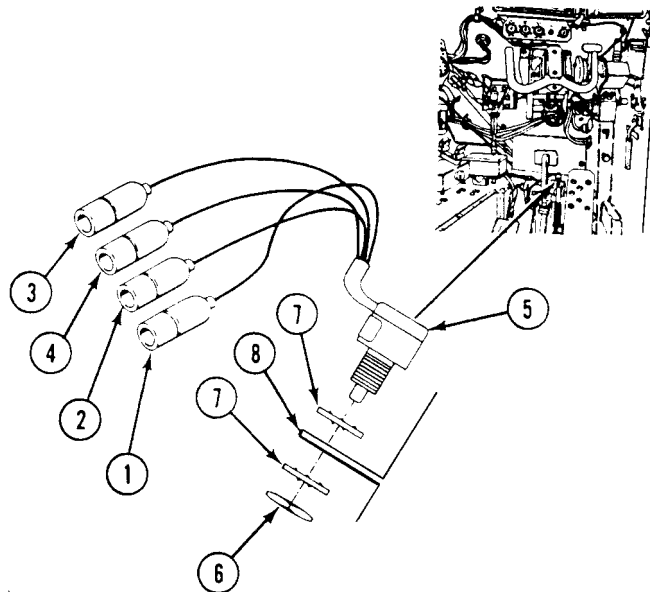

CLEANING

CLEANING AND INSPECTION

1. Clean switch (5) with cleaning compound.

REPLACE STOP SWITCH — Continued

0332 00

2. Check circuit 75A lead and circuit 75B lead for continuity with switch plunger depressed. If test indicates open circuit, replace defective switch.
3. Check circuit 366 lead and circuit 366A lead for continuity with switch plunger released. If test indicates open circuit, replace defective switch.

INSTALLATION

1. Place switch (5) on bracket (8). Secure with two washers (7) and jamnut (6).
2. Connect circuit 75A lead (1), circuit 75B lead (2), circuit 366 lead (3), and circuit 366A lead (4) to stop switch (5).

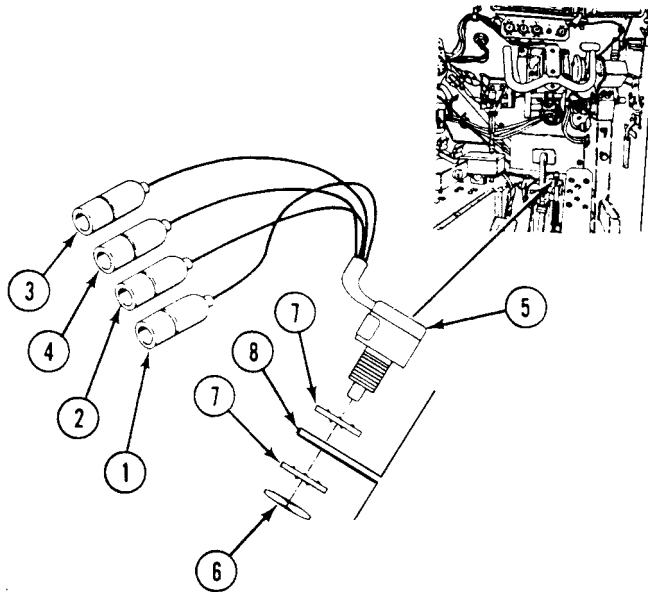
**END OF TASK**

REPLACE HEADLIGHT HIGH BEAM SELECTOR SWITCH

0333 00

THIS WORK PACKAGE COVERS:

Removal (page 0333 00-1).
 Installation (page 0333 00-2).

INITIAL SETUP:

Maintenance Level

Unit

Personnel Required

Unit Mechanic

Tools and Special Tools

General Mechanic's Tool Kit (WP 0926 00, Item 65)

References

See your -10

Materials/Parts

Lockwasher (2)

Equipment Condition

Engine stopped (see your -10)
 Carrier blocked (see your -10)

REMOVAL

1. From driver's compartment, remove two screws (1) and lockwashers (2) from bracket (3). Discard lockwashers.
2. Remove switch (4) from bracket (3).
3. Disconnect cable (5) from rear of light beam selector switch (4).

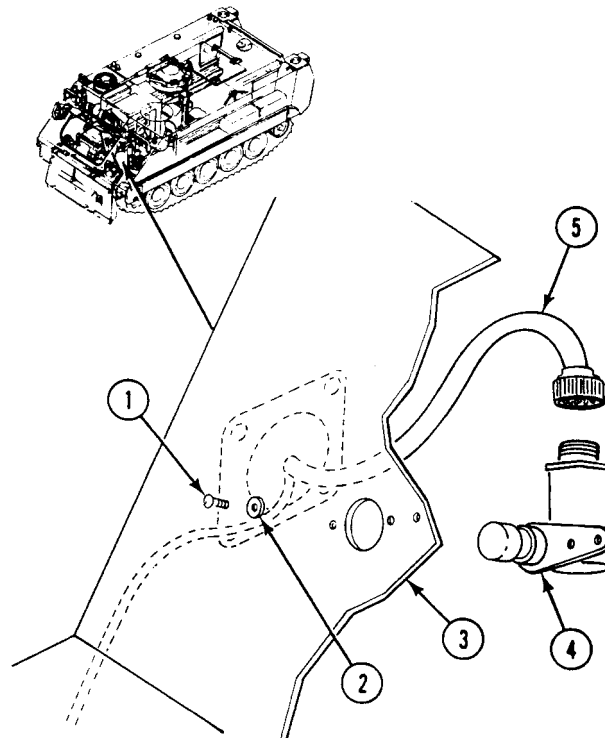

INSTALLATION

1. Connect cable (5) to rear of switch (4).
2. Install switch (4) in bracket (3).
3. Secure switch (4) to bracket (3) with two new lockwashers (2) and screws (1).

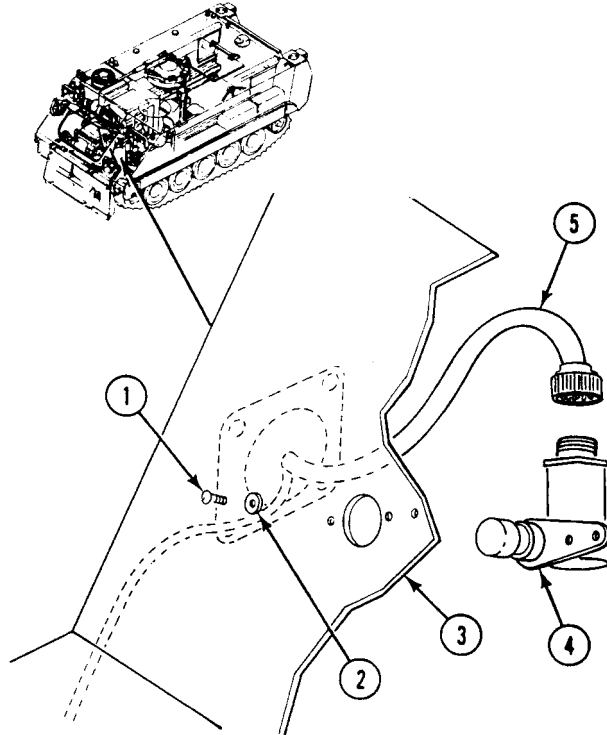
**FOLLOW-THROUGH STEPS**

1. Turn MASTER SWITCH ON (see your -10).
2. Turn on service headlights and operate beam selector switch to check that switch works right (see your -10).
3. Turn all switches OFF (see your -10).

END OF TASK

REPLACE ADMITTANCE BUZZER AND SWITCH (M577A3 AND M1068A3 ONLY)

0334 00

THIS WORK PACKAGE COVERS:

- Removal (page 0334 00-1).
- Inspection (page 0334 00-2).
- Installation (page 0334 00-2).

INITIAL SETUP:

Maintenance Level

Unit

Personnel Required

Unit Mechanic

Tools and Special Tools

General Mechanic's Tool Kit (WP 0926 00, Item 65)

References

See your -10

Materials/Parts

- Gasket
- Lockwasher (3)

Equipment Condition

- Engine stopped (see your -10)
- Carrier blocked (see your -10)
- Battery ground lead disconnected (WP 0338 00)

REMOVAL

1. Disconnect circuit 509 lead (1) from buzzer (2) and from buzzer switch (3).
2. Remove three screws (4), lockwashers (5) and buzzer (2) from weldnuts on left bulkhead. Discard lockwashers.
3. Remove nut (6), gasket (7), and buzzer switch (3) from rear bulkhead. Discard gasket.

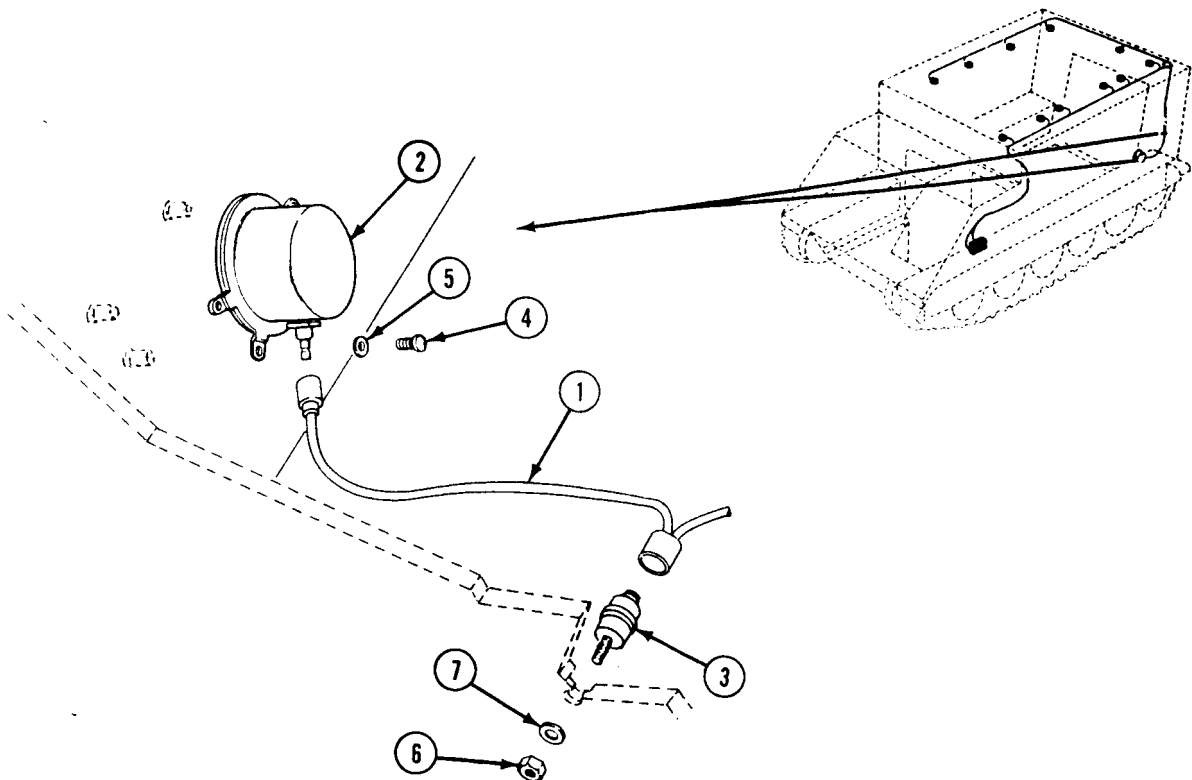

REPLACE ADMITTANCE BUZZER AND SWITCH (M577A3 AND M1068A3 ONLY) —
Continued

0334 00

INSPECTION-ACCEPTANCE AND REJECTION CRITERIA

1. Check buzzer and switch. See troubleshooting (WP 0042 00). Replace bad buzzer or switch.

INSTALLATION**NOTE**

A new buzzer switch is equipped with two nuts and two washers. Before installing new buzzer switch, discard one nut and one washer.

1. Install buzzer switch (1) in rear bulkhead. Secure with new gasket (2) and nut (3).
2. Place buzzer (4) on weldnuts on left bulkhead. Secure with three new lockwashers (5) and screws (6).
3. Connect circuit 509 lead (7) to buzzer (4) and to buzzer switch (1).

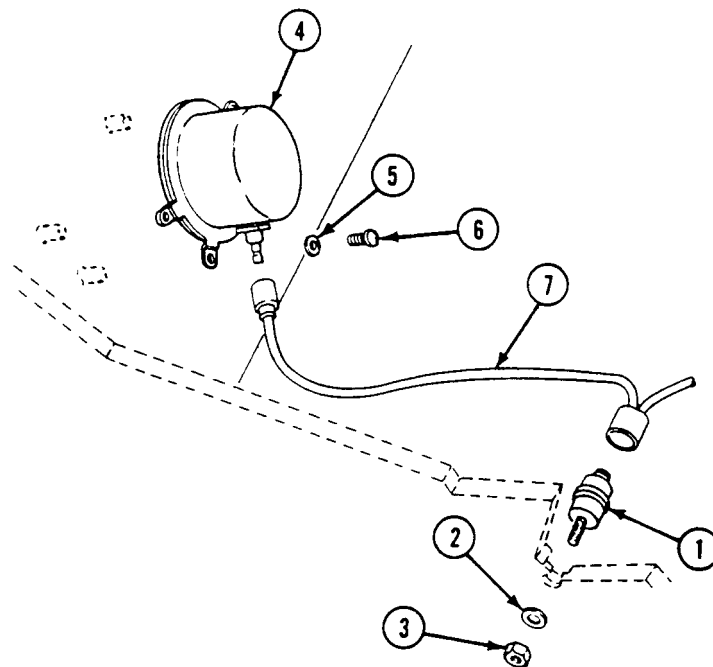
**FOLLOW-THROUGH STEPS**

1. Connect battery ground lead (WP 0338 00).
2. Turn MASTER SWITCH ON (see your -10).
3. Operate buzzer switch to check that buzzer and switch operate properly (see your -10).
4. Turn MASTER SWITCH OFF (see your -10).

END OF TASK

REPLACE RAMP DOOR SWITCH AND MOUNT (M577A3 AND M1068A3 ONLY)

0335 00

THIS WORK PACKAGE COVERS:

- Removal (page 0335 00-1).
- Inspection (page 0335 00-2).
- Installation (page 0335 00-3).
- Adjustment (page 0335 00-4).

INITIAL SETUP:

Maintenance Level

Unit

Personnel Required

Unit Mechanic

Tools and Special Tools

General Mechanic's Tool Kit (WP 0926 00, Item 65)

References

See your -10

Materials/Parts

Locknut (4)
Locknut

Equipment Condition

Engine stopped (see your -10)
Carrier blocked (see your -10)
Battery ground lead disconnected (WP 0338 00)

REMOVAL

1. Disconnect circuit 38 lead (1), circuit 38B lead (2), and circuit 38C lead (3) from ramp door switch (4).

**REPLACE RAMP DOOR SWITCH AND MOUNT (M577A3 AND M1068A3 ONLY) —
Continued**

0335 00

2. Remove locknut (5), screw (6), and retainer (7) from actuator (8). Discard locknut.
3. Remove switch (4) from actuator (8).
4. Remove two locknuts (9), washers (10), screws (11), and actuator (8) from bracket (12). Discard locknuts.
5. Remove two locknuts (13), screws (14), and bracket (12) from hull. Discard locknuts.

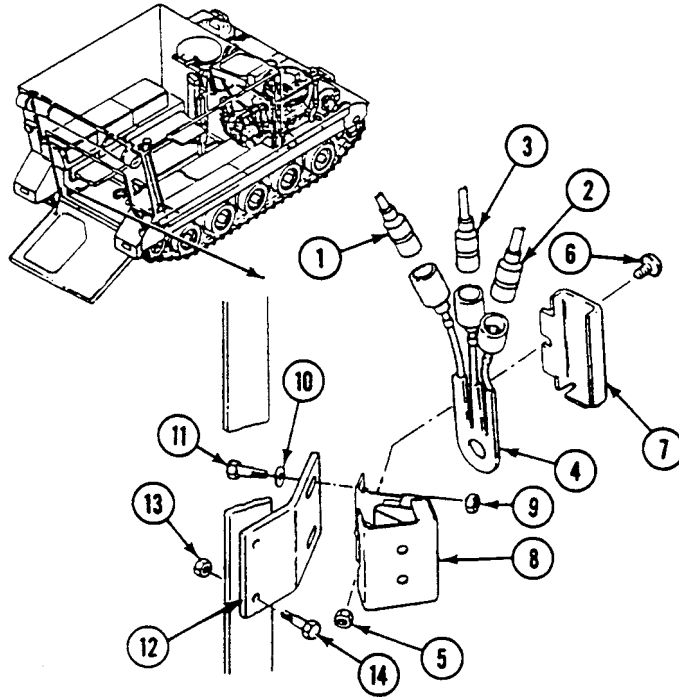
**INSPECTION-ACCEPTANCE AND REJECTION CRITERIA**

1. Check for cracks or other damage to switch. If damaged, replace switch.

REPLACE RAMP DOOR SWITCH AND MOUNT (M577A3 AND M1068A3 ONLY) —
Continued

0335 00

INSTALLATION

1. Place bracket (12) on hull. Secure with two screws (14) and new locknuts (13).
2. Place actuator (8) on bracket (12). Secure with two screws (11), washers (10), and new locknuts (9). Do not tighten screws until ramp door switch is adjusted (Steps 1 - 9).
3. Place switch (4) on actuator (8). Secure with retainer (7), screw (6), and new locknut (5).
4. Connect circuit 38C lead (3), circuit 38B lead (2), and circuit 38 lead (1) to ramp door switch (4).

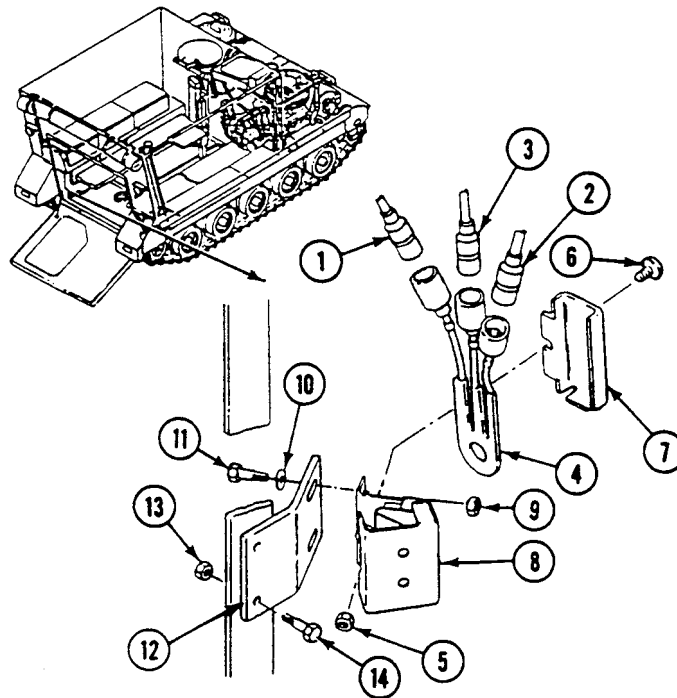

REPLACE RAMP DOOR SWITCH AND MOUNT (M577A3 AND M1068A3 ONLY) —
Continued

0335 00

ADJUSTMENT

1. Connect battery ground lead (WP 0338 00).
2. Start engine (see your -10).
3. Raise and lock ramp (see your -10).
4. Stop engine (see your -10).
5. Loosen two screws (1) and slide switch (2) as far as possible from hull.
6. Lock ramp door handle (3) against stop (4) (see Position 1 – Against Stop).
7. Slide switch (2) against handle (3) to get approximately 1/4 inch (7 mm) clearance. Tighten screws (1).
8. Move handle (3) against detent (5) (see Position 2 – Against Detent). Clearance should be approximately 5/8 inch (16 mm).
9. Check switch for proper operation. When handle (3) is in Position 2 (Against Detent), interior lights (white) should come on and blue light should be off. When handle is in Position 1 (Against Stop) interior lights (white) should be off and blue lights should be on. Repeat Steps 5 - 9 to make adjustments until switch operates correctly.

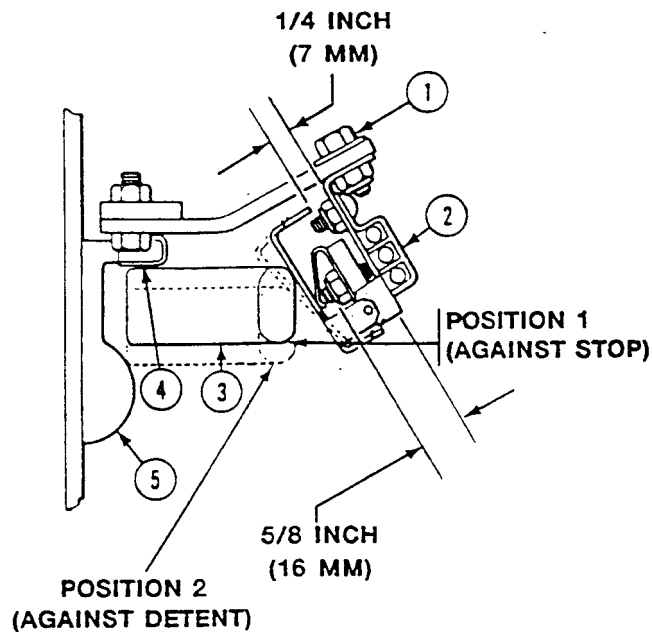
**FOLLOW-THROUGH STEPS**

1. Turn MASTER SWITCH to ON (see your -10).
2. Turn on dome lights and open ramp access door (see your -10). All dome lights should go off and blackout lights should come on.
3. Turn all switches OFF (see your -10).
4. Turn MASTER SWITCH to OFF (see your -10).

END OF TASK

REPLACE HORN AND GROUND LEAD

0336 00**THIS WORK PACKAGE COVERS:**

Removal (page 0336 00-1).
 Installation (page 0336 00-3).

INITIAL SETUP:Maintenance Level

Unit

References

See your -10

Tools and Special Tools

General Mechanic's Tool Kit (WP 0926 00, Item 65)

Equipment ConditionMaterials/Parts

Lockwasher

Engine stopped (see your -10)

Carrier blocked (see your -10)

Personnel Required

Unit Mechanic

Battery ground strap disconnected (WP 0337 00),
(WP 0338 00), or (WP 0339 00)

REMOVAL**NOTE**

If ground lead is to be replaced only, do Removal Step 1 and Step 3, Installation Step 1 and Step 3.

1. Disconnect ground lead (1) and circuit 25 lead (2) from horn (3).
2. Remove two screws (4), lockwashers (5), and horn (3) from hull bracket (6).

3. Remove nut (7), lockwasher (8), ground lead (1), washer (9), and screw (10) from bracket (6). Discard lockwasher.

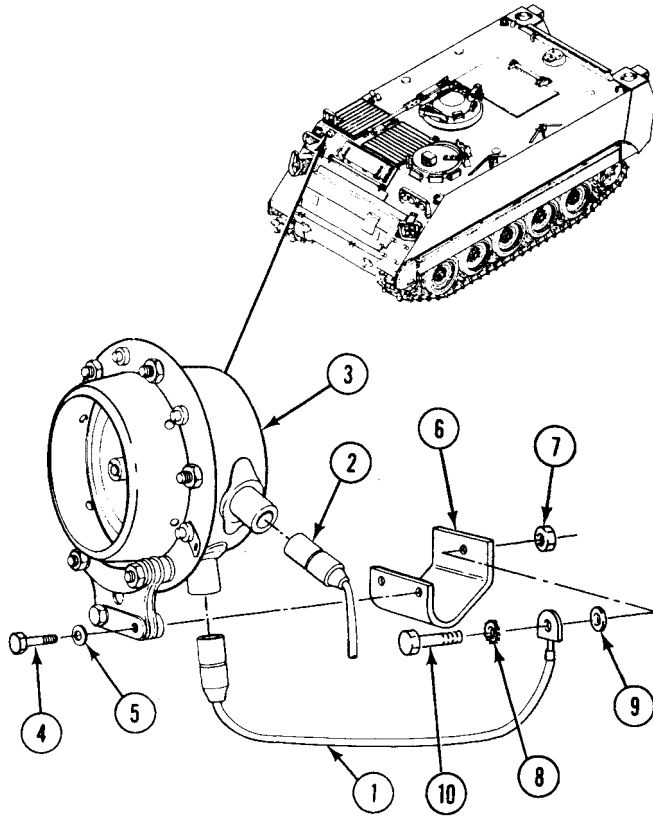

INSTALLATION

1. Install ground lead (1) on bracket (6). Secure with screw (10), washer (9), new lockwasher (8), and nut (7).
2. Install horn (3) on bracket (6). Secure with two lockwashers (5) and screws (4).
3. Connect circuit 25 lead (2) and ground lead (1) to horn (3).

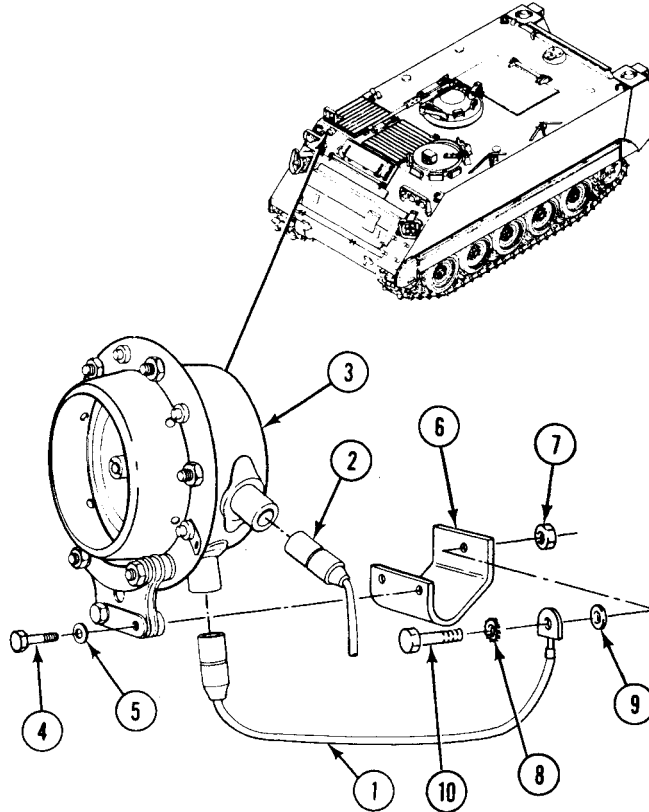
**FOLLOW-THROUGH STEPS**

1. Connect battery ground strap (WP 0337 00), (WP 0338 00), (WP 0339 00).
2. Turn MASTER SWITCH ON (see your -10).
3. Press HORN switch to check that horn works (see your -10).
4. Turn MASTER SWITCH OFF (see your -10).

END OF TASK

DISCONNECT/CONNECT BATTERY GROUND STRAP (M113A3, M1059A3, M1064A3, AND M58 ONLY)

0337 00 ■

THIS WORK PACKAGE COVERS:

Disconnect (page 0337 00-1).
 Connect (page 0337 00-2).

INITIAL SETUP:

Maintenance Level

Unit

References

See your -10

Tools and Special Tools

General Mechanic's Tool Kit (WP 0926 00, Item 65)

Equipment Condition

Engine stopped (see your -10)

Materials/Parts

Insulation tape (WP 0928 00, Item 39)

Locknut

Carrier blocked (see your -10)

Personnel Required

Unit Mechanic

All radios and heaters OFF (see your -10)

Spall liners opened (M113A3 only) (see your -10)

DISCONNECT

WARNING



Battery posts and cables touched by metal objects can short circuit and burn you or injure you. Use caution when you work with tools or other metal objects. Do not wear jewelry when you work on electrical system.

Some circuits remain energized even when MASTER SWITCH is OFF. Make sure ground strap is disconnected when there is any possibility that the circuit you are working on could be energized.

■ DISCONNECT/CONNECT BATTERY GROUND STRAP (M113A3, M1059A3, M1064A3, AND M58 ONLY) — Continued

0337 00

NOTE

Battery shunts are located differently, and some have guards, and some have cables, but all ground straps/cables are disconnected the same.

1. Remove locknut (5), screw (1), two lockwashers (2), and ground strap (3) from hull lug (4). Discard locknut and lockwashers.
2. Tape all of ground strap (3) with insulation tape.

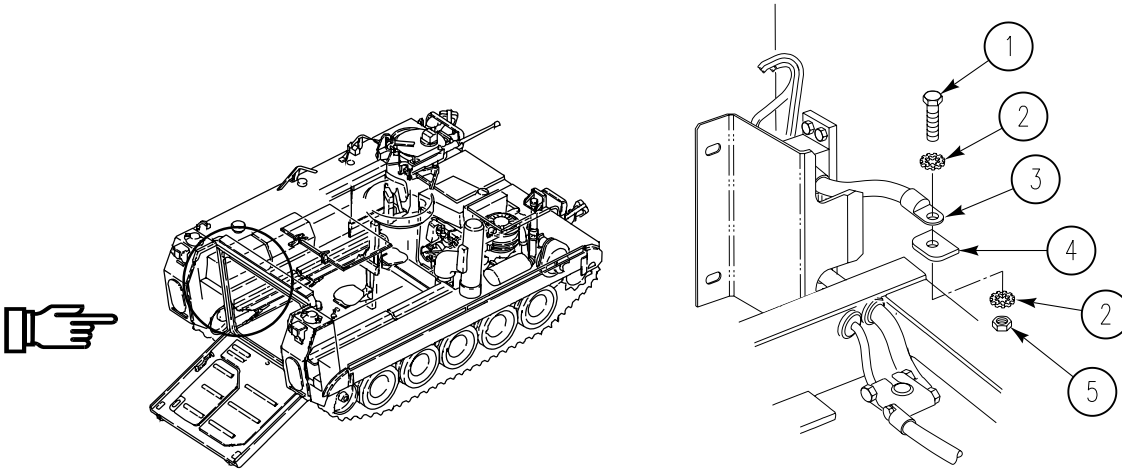

CONNECT

1. Remove tape from ground strap (3).
2. Install ground strap (3) on hull lug (4). Secure with two new lockwashers (2), screw (1), and new locknut (5).

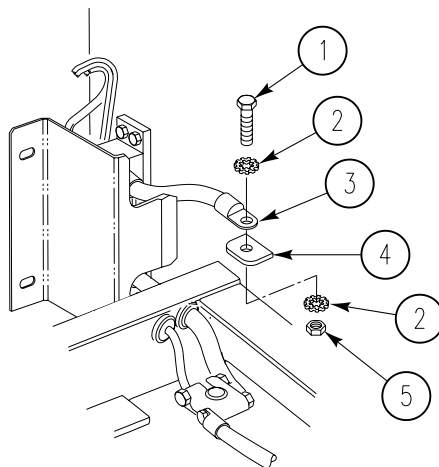

END OF TASK

DISCONNECT/CONNECT BATTERY GROUND LEAD (M577A3 AND M1068A3 ONLY)

0338 00

THIS WORK PACKAGE COVERS:

Disconnect (page 0338 00-1).
 Connect (page 0338 00-3).

INITIAL SETUP:

Maintenance Level

Unit

References

See your -10

Tools and Special Tools

General Mechanic's Tool Kit (WP 0926 00, Item 65)

Equipment Condition

Engine stopped (see your -10)
 Carrier blocked (see your -10)
 All radios and heaters OFF (see your -10)
 Battery access cover removed (see your -10)

Materials/Parts

Insulation tape (WP 0928 00, Item 39)

Personnel Required

Unit Mechanic

REMOVAL

DISCONNECT

WARNING



Battery posts and cables touched by metal objects can short circuit, and burn you or injure you. Use caution when working with tools or other metal objects. Do not wear jewelry when working on electrical systems.

Some circuits remain energized even when MASTER SWITCH is OFF. Make sure ground lead is disconnected if there is any possibility that the circuit you are working on could be energized.

DISCONNECT/CONNECT BATTERY GROUND LEAD (M577A3 AND M1068A3 ONLY) —
Continued

0338 00

1. Remove nut (1) and ground lead (2) from battery negative terminal (3). Reinstall nut to secure other lead to terminal.
2. Tape end of ground lead (2) with insulation tape.

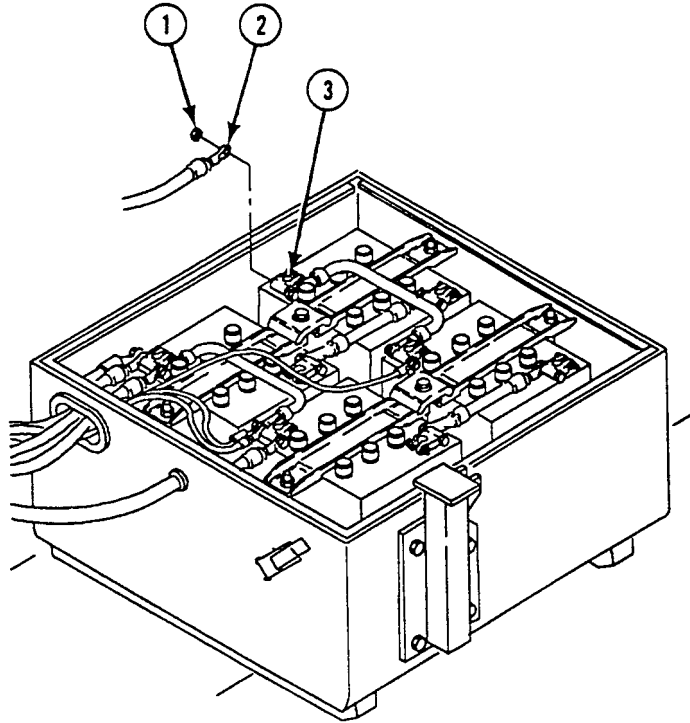

DISCONNECT/CONNECT BATTERY GROUND LEAD (M577A3 AND M1068A3 ONLY) —
Continued

0338 00

INSTALLATION**CONNECT**

1. Remove tape from ground lead (2).
2. Remove nut (1) from battery negative terminal (3). Install ground lead (2) on battery negative terminal. Secure with nut (1).

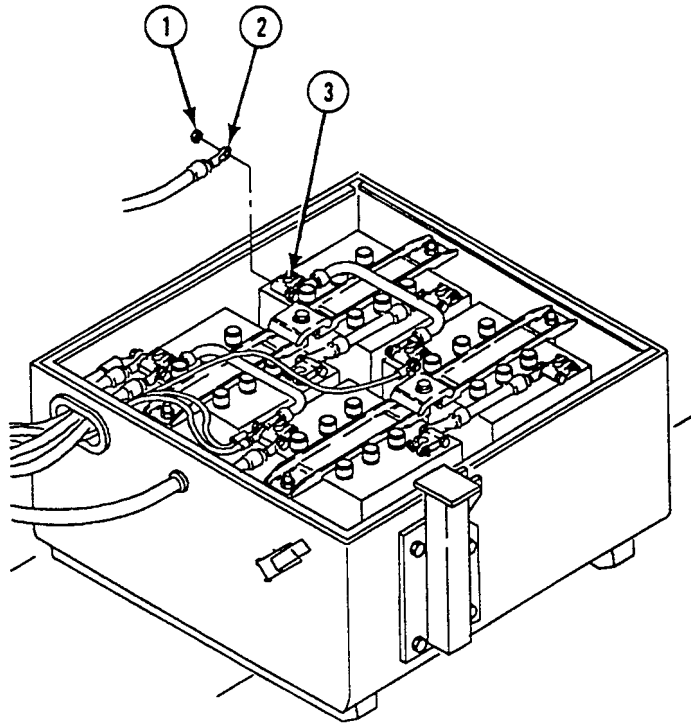
**FOLLOW-THROUGH STEPS**

1. Install battery access cover (see your -10).

END OF TASK

REPLACE BATTERY LEADS AND TERMINALS (M113A3 AND M1059A3 ONLY)

0340 00 ■

THIS WORK PACKAGE COVERS:

- Removal (page 0340 00-1).
- Cleaning and Inspection (page 0340 00-3).
- Installation (page 0340 00-4).

INITIAL SETUP:

Maintenance Level

Unit

References

See your -10

Tools and Special Tools

- General Mechanic's Tool Kit (WP 0926 00, Item 65)
- Battery Wire Brush (WP 0926 00, Item 10)
- Battery Terminal Puller (WP 0926 00, Item 37)

Equipment Condition

- Engine stopped (see your -10)
- Carrier blocked (see your -10)
- Ramp lowered (see your -10)
- Battery ground strap disconnected (WP 0337 00)
- Spall liners opened (M113A3) (see your -10)
- Battery access covers removed (see your -10)

Materials/Parts

- Grease (WP 0928 00, Item 12)
- Sodium bicarbonate (WP 0928 00, Item 60)
- Grommet (3)

Personnel Required

Unit Mechanic

REMOVAL

1. Remove screw (1), washer (2), and lead (3) from shunt (4).

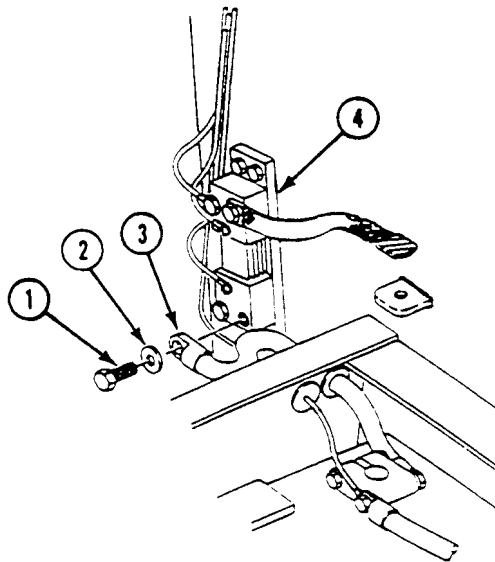

REPLACE BATTERY LEADS AND TERMINALS (M113A3 AND M1059A3 ONLY)

0340 00

— Continued

NOTE

All leads are disconnected from four batteries in the same way.

Terminal connectors may be hard to remove from battery posts. Use battery terminal puller to remove terminals.

2. Remove nut (5), screw (6), and three leads (7) from negative terminal (8) of fourth battery (9).

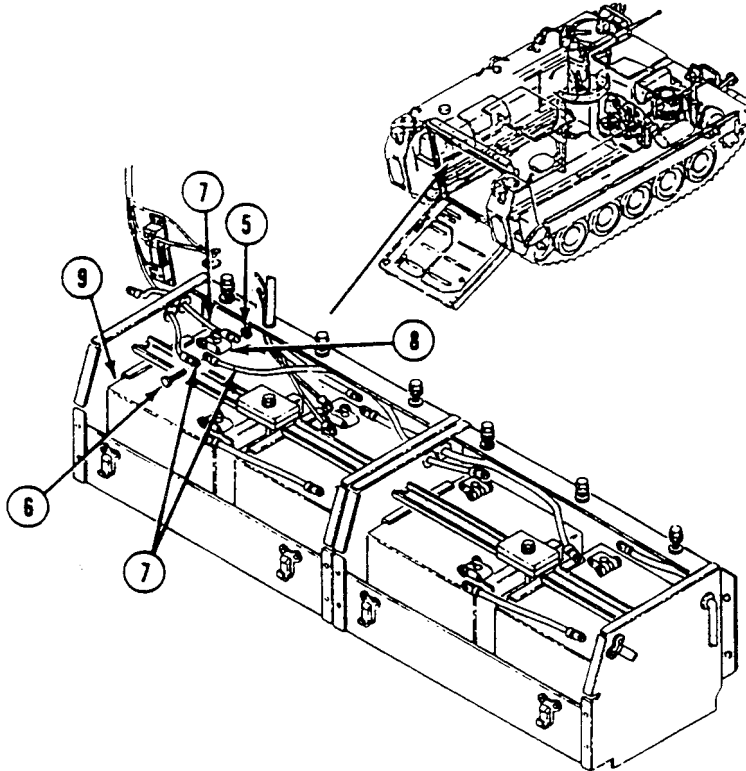

REPLACE BATTERY LEADS AND TERMINALS (M113A3 AND M1059A3 ONLY)

0340 00 ■

— Continued

3. Remove five leads (1) and three grommets (2) from battery boxes (3). Discard grommets.
4. Remove eight nuts (4), screws (5), terminals (6), and rubber shields (7) from batteries (8). Use battery terminal puller.

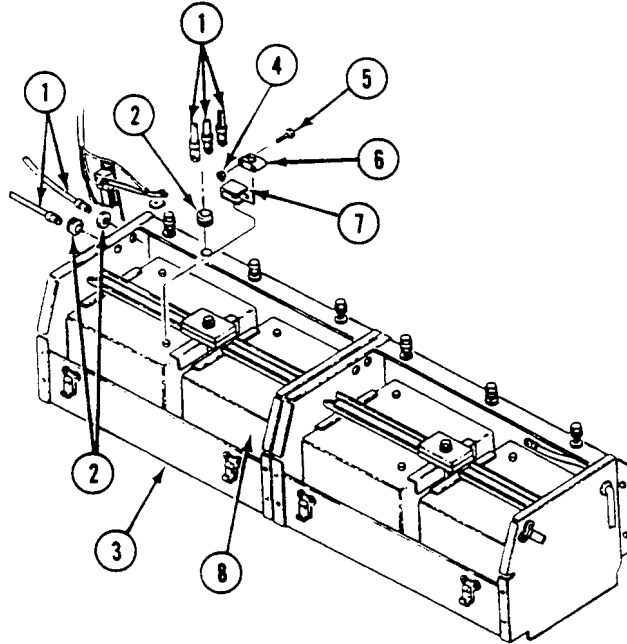
**CLEANING****CLEANING AND INSPECTION**

1. Clean battery covers, terminals, battery posts, and lead connectors with brush dipped in mixture of sodium bicarbonate and water. After foaming stops, flush parts with clean water. Dry with clean cloth.
2. Clean terminals and posts with battery wire brush.

REPLACE BATTERY LEADS AND TERMINALS (M113A3 AND M1059A3 ONLY)

0340 00

— Continued

INSTALLATION**CAUTION**

Battery cells can be damaged if the battery is hooked up incorrectly. Make sure battery is hooked up correctly.

1. Install eight terminals (6) on rubber shields (7) on four batteries (8). Secure with eight nuts (4), and screws (5).
2. Install two new grommets (2) on two leads (1). Install new grommet (2) on three leads (1). Route leads in battery box (3). Install grommets in box.

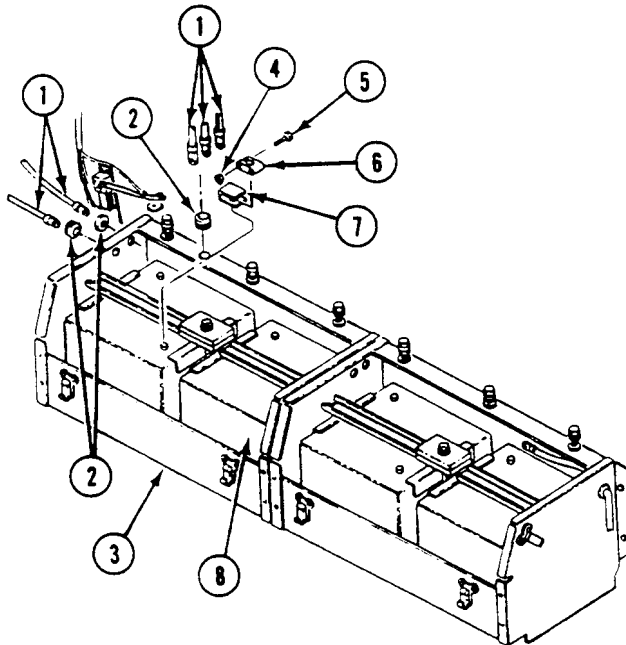

REPLACE BATTERY LEADS AND TERMINALS (M113A3 AND M1059A3 ONLY)

0340 00 ■

— Continued

NOTE

All leads are connected to eight battery terminals in the same way.

3. Install three leads (9) on negative terminal (10) of fourth battery (11). Secure with screw (12) and nut (13).
4. Coat tops of eight battery terminals (14) with grease.

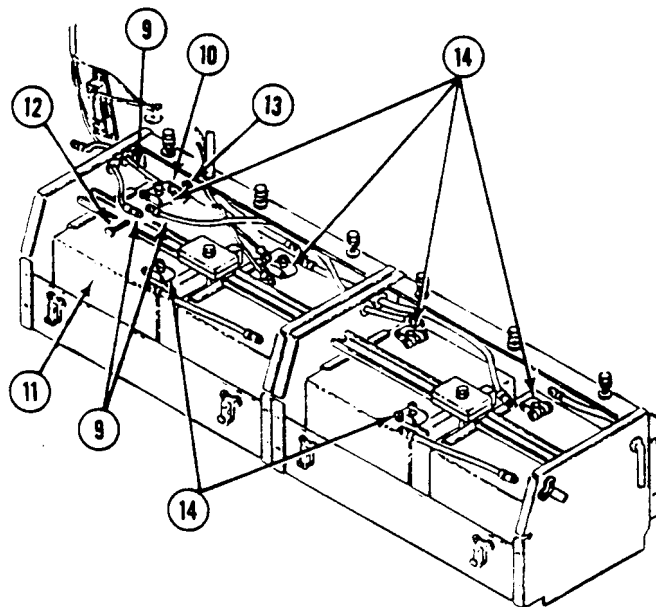
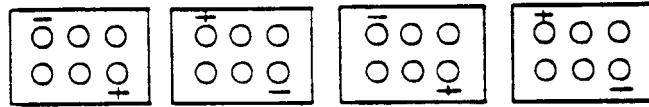

REPLACE BATTERY LEADS AND TERMINALS (M113A3 AND M1059A3 ONLY)

0340 00

— Continued

5. Install lead (1) on shunt (2). Secure with screw (3) and washer (4).

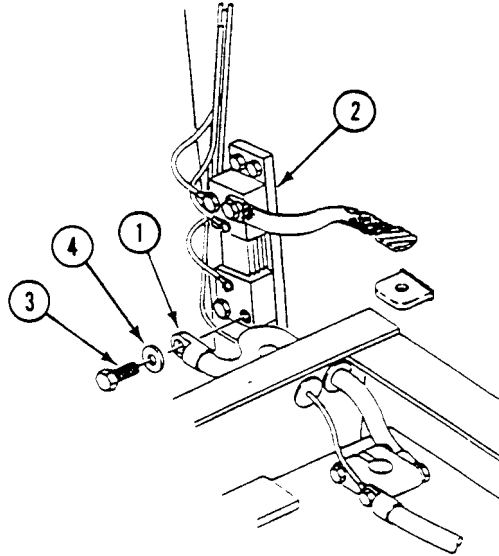
**FOLLOW-THROUGH STEPS**

1. Install battery access covers (see your -10).
2. Connect battery ground strap (WP 0337 00).
3. Turn MASTER SWITCH to ON. Check BATT-GEN gage on instrument panel. Gage should read in yellow zone (see your -10).
4. Start engine (see your -10).
5. Raise and lock ramp (see your -10).
6. Stop engine (see your -10).

END OF TASK

REPLACE BATTERY LEADS AND TERMINALS (M577A3 AND M1068A3 ONLY)

0341 00

THIS WORK PACKAGE COVERS:

- Removal (page 0341 00-1).
- Cleaning and Inspection (page 0341 00-3).
- Installation (page 0341 00-4).

INITIAL SETUP:

Maintenance Level

Unit

References

See your -10

Tools and Special Tools

- General Mechanic's Tool Kit (WP 0926 00, Item 65)
- Battery Wire Brush (WP 0926 00, Item 10)
- Battery Terminal Puller (WP 0926 00, Item 37)

Equipment Condition

- Engine stopped (see your -10)
- Carrier blocked (see your -10)
- Ramp lowered (see your -10)
- Battery access cover removed (see your -10)
- Battery ground lead disconnected (WP 0338 00)
- Personnel heater removed (for STE/ICE shunt leads only) (WP 0703 00)

Materials/Parts

- Grease (WP 0928 00, Item 12)
- Sodium bicarbonate (WP 0928 00, Item 60)
- Grommet (2)

Personnel Required

Unit Mechanic

REMOVAL

WARNING



Electrical current can burn you. Disconnect ground lead before starting task.

1. Remove screw (1), washer (2), and ground lead (3) from shunt (4).

REPLACE BATTERY LEADS AND TERMINALS (M577A3 AND M1068A3 ONLY) —
Continued

0341 00

2. Remove nut (5), screw (6), washer (7), ground lead (3), and negative-to-negative lead (8) from terminal (9).
3. Remove nut (10), screw (11), washer (12), circuit lead 779 (13), and negative-to-negative lead (8) from terminal (14).
4. Remove four nuts (15), screws (16), washers (17), and two positive-to-negative leads (18) and (19) from terminal (20).

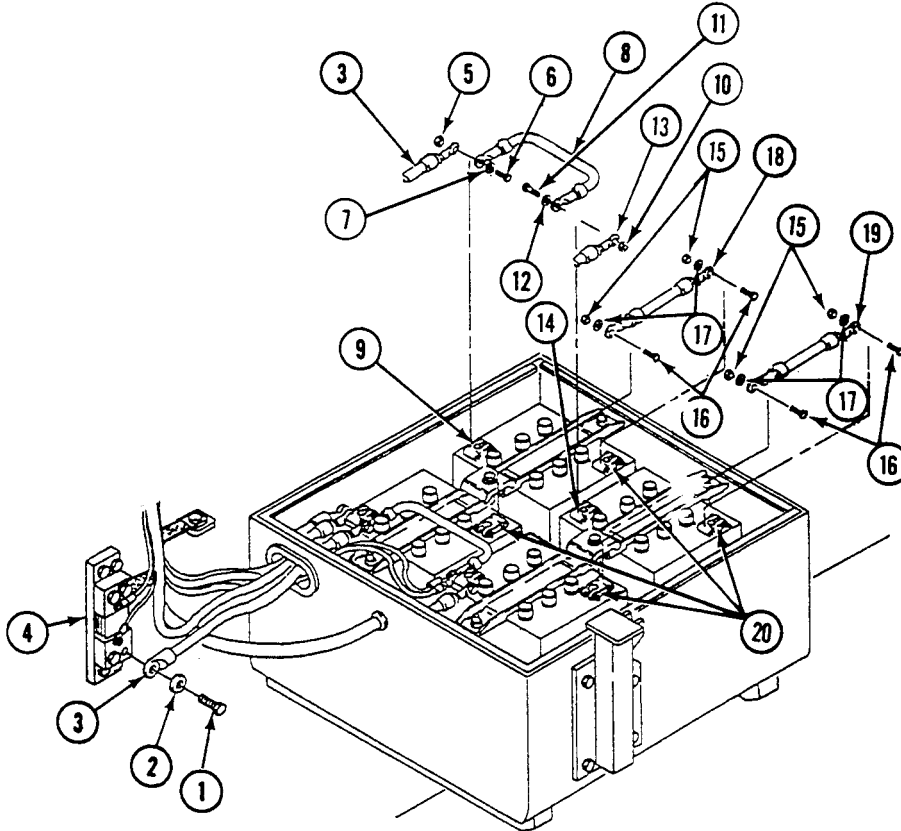

**REPLACE BATTERY LEADS AND TERMINALS (M577A3 AND M1068A3 ONLY) —
Continued**

0341 00

5. Remove nut (1), screw (2), washer (3), circuit leads 772 (4), 778 (5), and 6 (6), and positive-to-positive terminal lead (7) from terminal (8).
6. Remove nut (9), screw (10), washer (11), circuit lead 6 (12), circuit lead 48B (13), cable W4 (14) and positive-to-positive terminal lead (7) from terminal (15).
7. Remove eight leads and two grommets (16) and (17) from battery box (18). Discard grommets.
8. Remove eight nuts (19), screws (20), and eight terminals (8), (15), and (21) from battery posts (22).

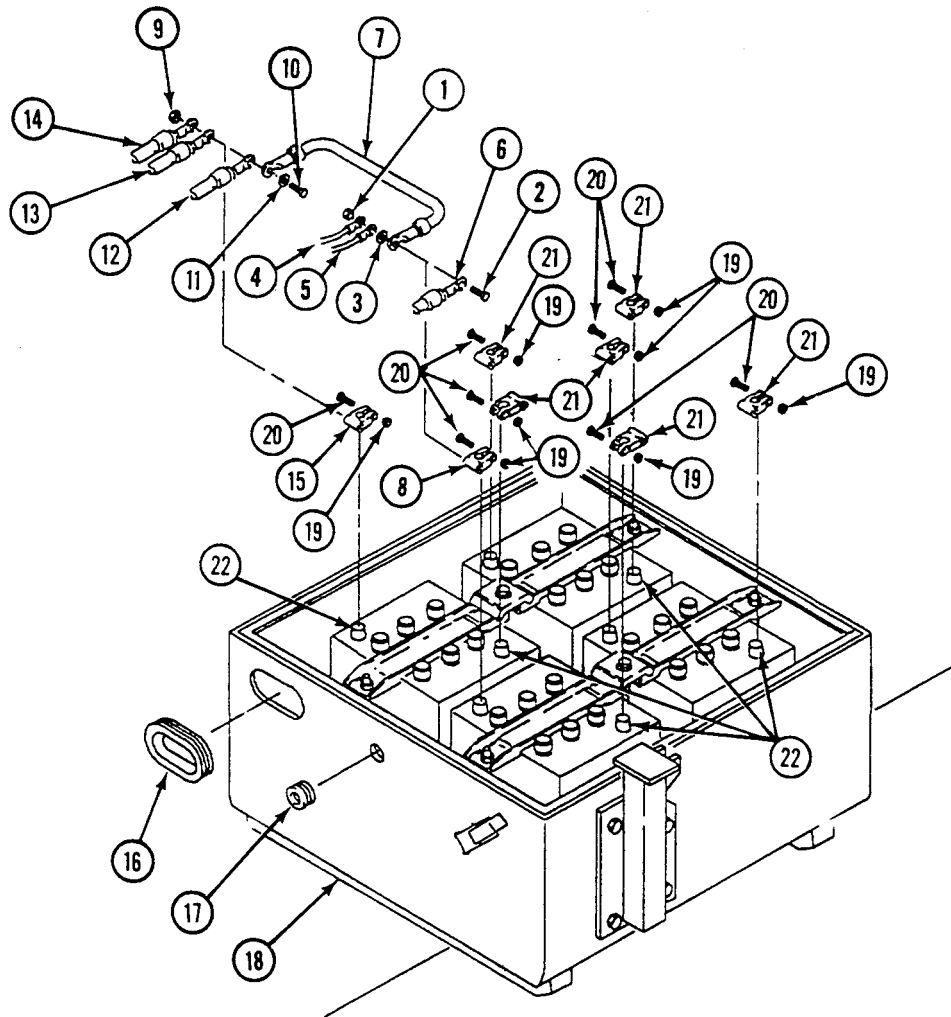

CLEANING

CLEANING AND INSPECTION

1. Clean battery covers, terminals, battery posts, and lead connectors with mixture of sodium bicarbonate and water. When foaming stops, flush parts with clean water. Dry with clean cloth.
2. Clean terminals and battery posts with battery wire brush.

INSTALLATION

CAUTION

Battery cells can be damaged if battery is hooked up incorrectly. Make sure battery is hooked up correctly.

1. Install eight terminals (1), (2), and (3) on clean battery posts (4).
2. Secure eight terminals with eight screws (5) and nuts (6).
3. Install new grommet (7) on circuit lead 6 (8). Install grommet and lead in battery box (9).
4. Install seven leads in battery box (9) with new grommet (10).
5. Connect circuit leads 772 (11), 778 (12), 6 (8), and positive-to-positive terminal lead (13) to terminal (2) with screw (14), washer (15), and nut (16).
6. Connect circuit lead 48B (17), cable W4 (18), circuit lead 6 (19), and positive-to-positive terminal lead (13) to terminal (3) with screw (20), washer (21), and nut (22).

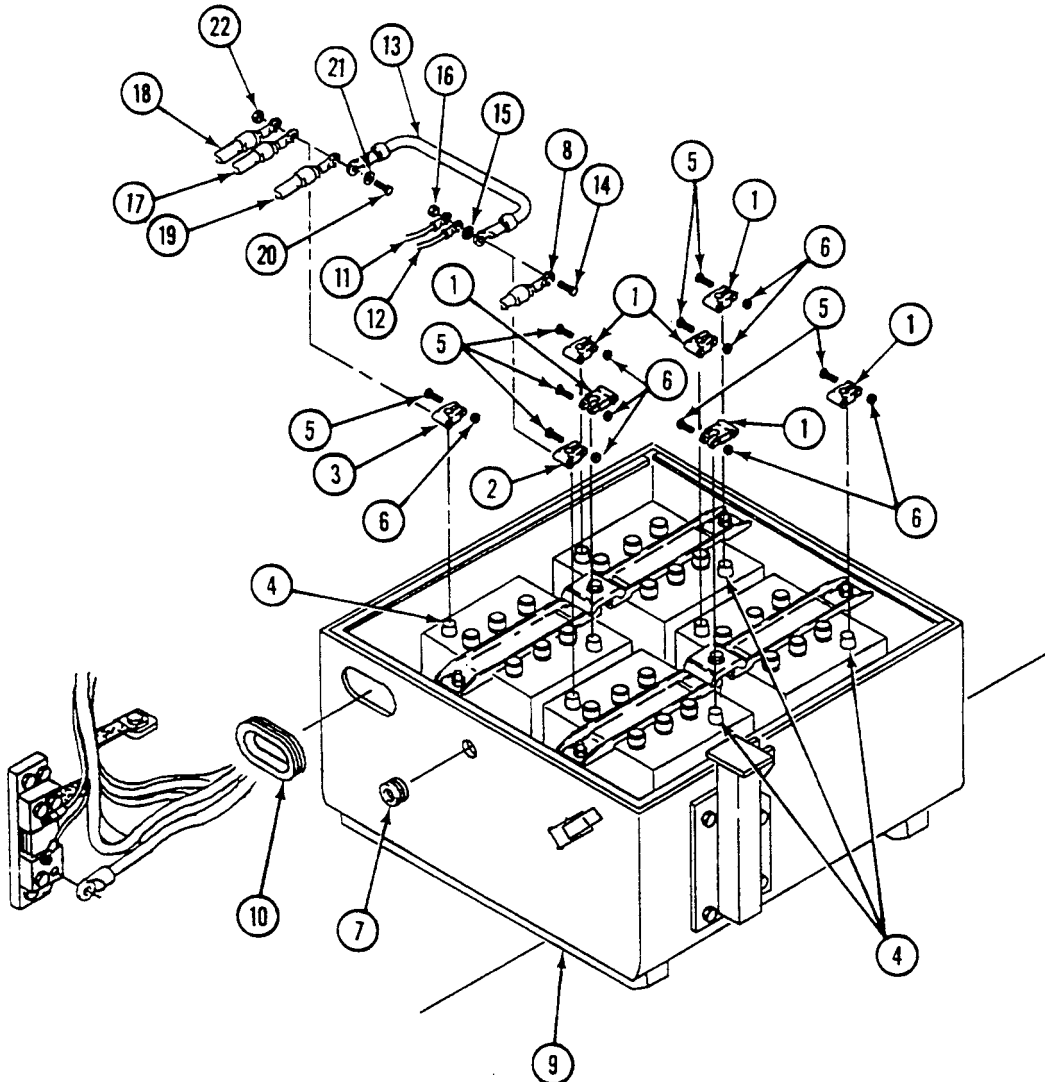

**REPLACE BATTERY LEADS AND TERMINALS (M577A3 AND M1068A3 ONLY) —
Continued**

0341 00

7. Install two positive-to-negative leads (1) and (2) on four terminals (3). Secure leads with four screws (4), washers (5), and nuts (6).
8. Connect ground lead (7) and negative-to-negative lead (8) to terminal (9) with screw (10), washer (11), and nut (12).
9. Connect circuit lead 779 (13) and negative-to-negative lead (8) to terminal (14) with screw (15), washer (16), and nut (17).
10. Coat tops of eight battery terminals with grease.
11. Install ground lead (7) on shunt (18). Secure with screw (19) and washer (20).

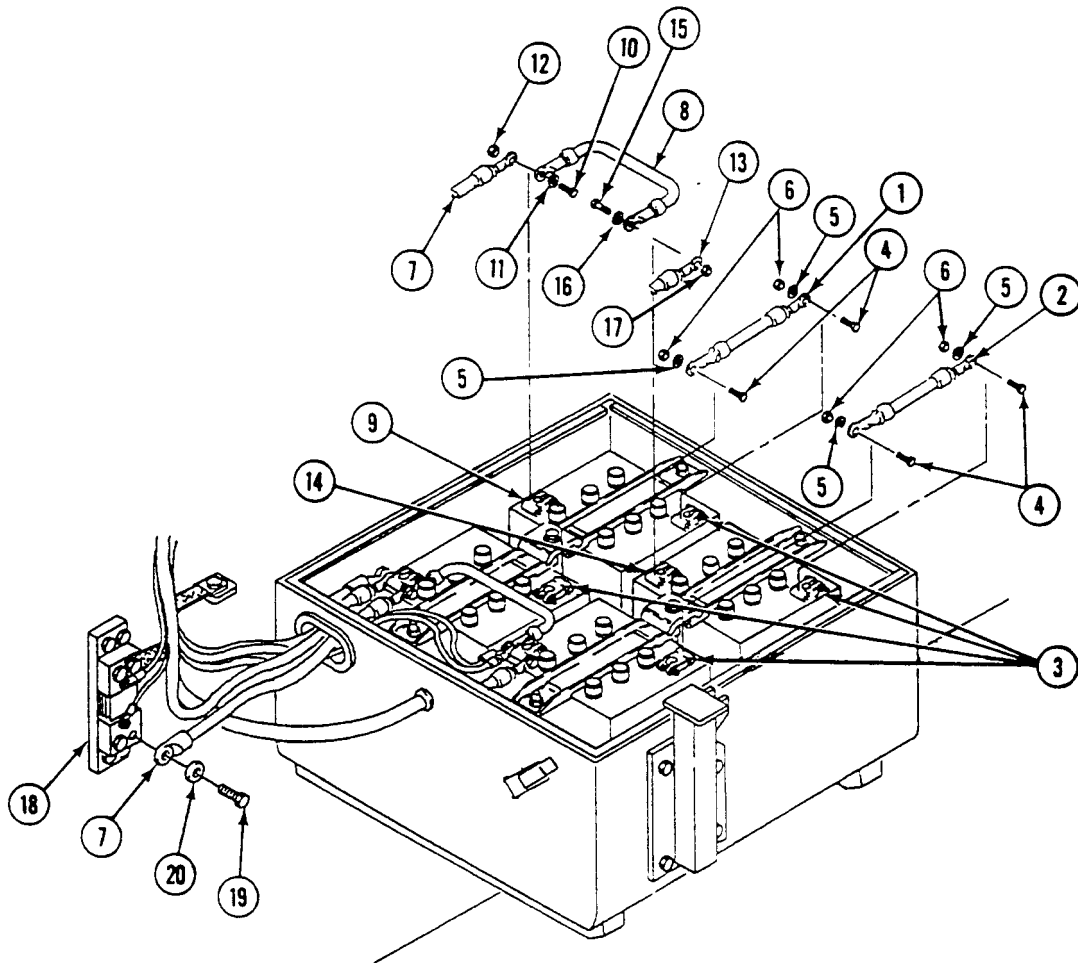

REPLACE BATTERY LEADS AND TERMINALS (M577A3 AND M1068A3 ONLY) —
Continued

0341 00

FOLLOW-THROUGH STEPS

1. Install personnel heater, if removed (WP 0703 00).
2. Connect battery ground lead (WP 0338 00).
3. Install battery access cover (see your -10).
4. Turn MASTER SWITCH ON. Check BATT-GEN gauge on instrument panel. Gage should read in yellow zone (see your -10).
5. Start engine (see your -10).
6. Raise and lock ramp (see your -10).
7. Stop engine (see your -10).

END OF TASK

REPLACE BATTERY LEADS AND TERMINALS (LEFT SIDE) (M1064A3 ONLY)

0343 00

THIS WORK PACKAGE COVERS:

- Removal (page 0343 00-1).
- Cleaning and Inspection (page 0343 00-5).
- Installation (page 0343 00-5).

INITIAL SETUP:

Maintenance Level

Unit

Personnel Required

Unit Mechanic

Tools and Special Tools

- General Mechanic's Tool Kit (WP 0926 00, Item 65)
- Battery Wire Brush (WP 0926 00, Item 10)
- Battery Terminal Puller (WP 0926 00, Item 37)

References

See your -10

Materials/Parts

- Grease (WP 0928 00, Item 12)
- Sodium bicarbonate (WP 0928 00, Item 60)
- Grommet (3)
- Grommet
- Lockwasher (5)
- Lockwasher
- Tiedown strap (2)

Equipment Condition

- Engine stopped (see your -10)
- Carrier blocked (see your -10)
- Ramp lowered (see your -10)
- Battery ground strap disconnected (WP 0337 00)
- Front floor plates removed (WP 0543 00)
- Battery leads (right side) removed (WP 0344 00)

REMOVAL

WARNING



Battery posts and cables touched by metal objects can short circuit and burn you. Do not wear jewelry, necklaces, or watches when working on the electrical system. Keep tools away from posts, wires, and terminals.

WARNING



Gas from batteries can explode and injure you. Do not allow sparks near batteries. Battery acid can burn or blind you. Do not get acid on your skin or eyes. ALWAYS disconnect ground lead first and connect it last.

REPLACE BATTERY LEADS AND TERMINALS (LEFT SIDE) (M1064A3 ONLY) —
Continued

0343 00

CAUTION

Do not start carriers while batteries are disconnected. Starting engine with outside power while batteries are disconnected will damage electrical components in the regulator.

1. Turn handle and pull battery drawer (1) out.
2. Remove nut (2), screw (3), circuit 772 lead (4), circuit 778 lead (5), circuit 6 lead (6), circuit 48 lead (7), and circuit 6P lead (8) from terminal lug (9).

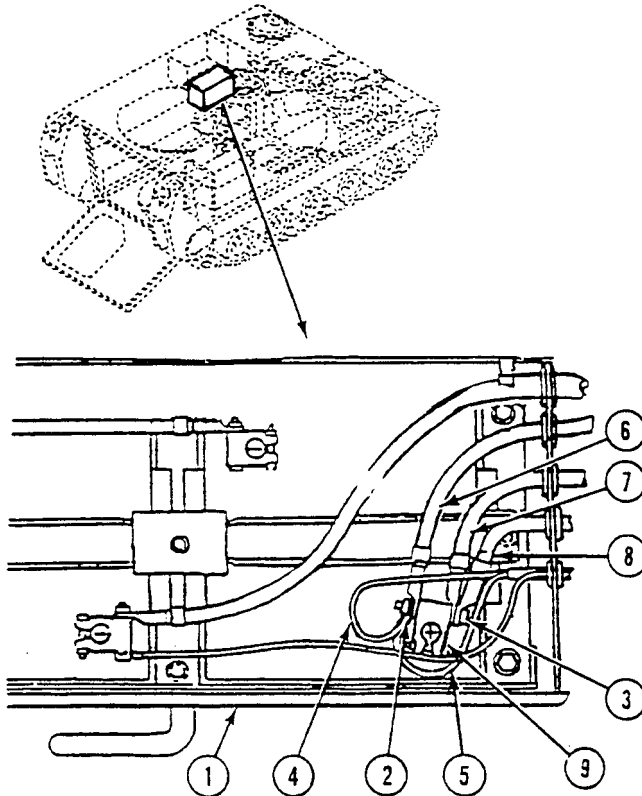

**REPLACE BATTERY LEADS AND TERMINALS (LEFT SIDE) (M1064A3 ONLY) —
Continued**

0343 00

3. Remove circuit 6 lead (1), circuit 48 lead (2), circuit 6P lead (3) and grommets (4) from battery compartment. Discard grommets.
4. Loosen nut (5) on screw (6) and remove terminal lug (7) and terminal lug cover (8) from battery post. Use battery terminal puller.
5. Remove screw (9), lockwasher (10), and circuit 6N lead (11) from shunt (12). Discard lockwasher.
6. Remove two tiedown straps (13) from circuit 6N lead (11) and circuit 6P lead (14).

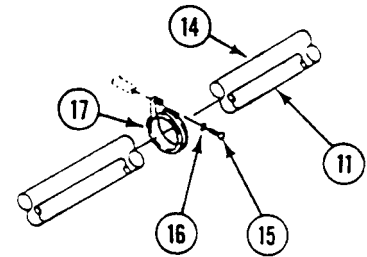
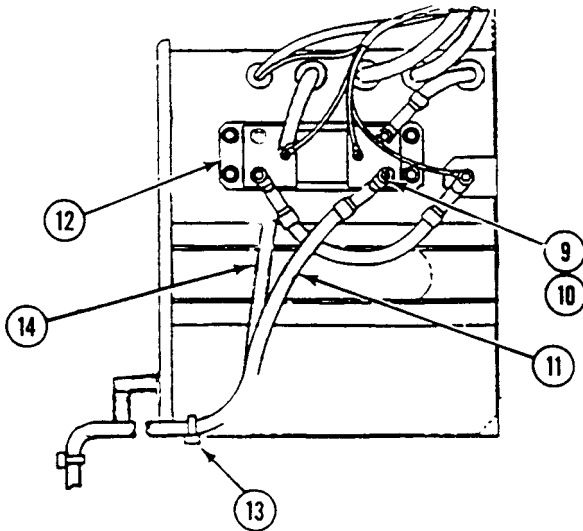
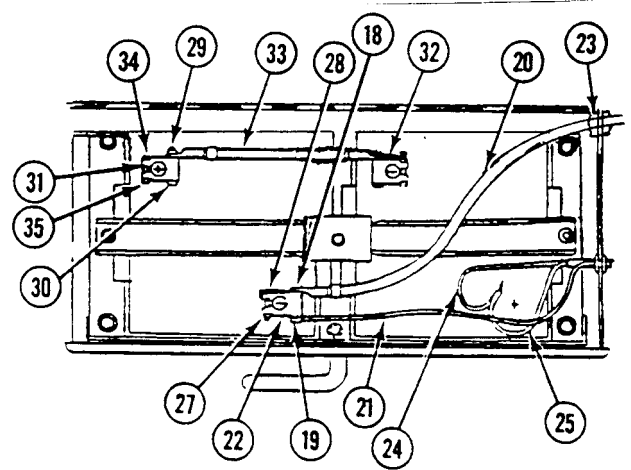
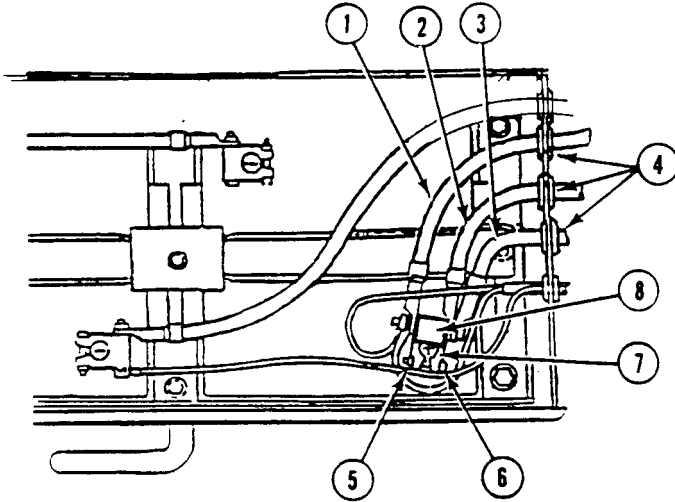

REPLACE BATTERY LEADS AND TERMINALS (LEFT SIDE) (M1064A3 ONLY) —
Continued

0343 00

7. Remove five screws (15), lockwashers (16) and clamps (17) from weldnuts. Discard lockwashers.
8. Remove nut (18), screw (19), circuit 7 lead (20) and circuit 779 lead (21) from negative terminal lug (22).
9. Remove circuit 7 lead (20) and grommet (23) from battery compartment. Discard grommet.
10. Remove circuit 779 lead (21), circuit 772 lead (24), and circuit 778 lead (25) and grommet (26) from battery compartment. Discard grommet.
11. Loosen nut (27) on screw (28) and remove terminal lug (22). Use battery terminal puller.
12. Remove two nuts (29) and screws (30) from positive terminal lug (31) and negative terminal lug (32). Remove jumper lead (33).
13. Loosen two nuts (34) on screws (35) and remove terminal lugs (31) and (32). Use battery terminal puller.

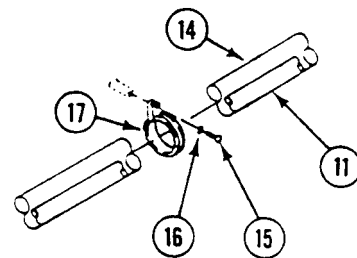
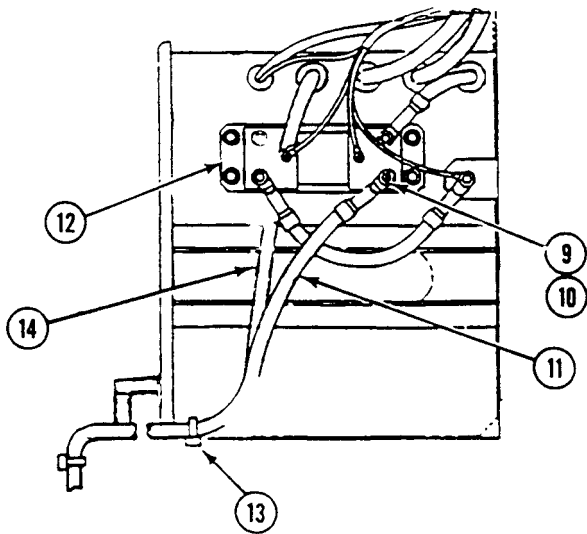
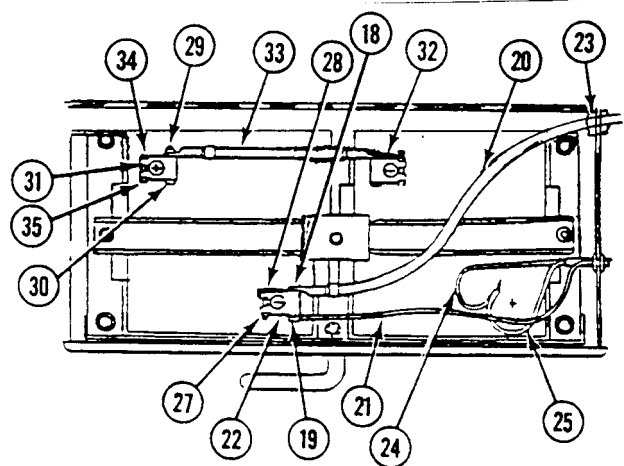
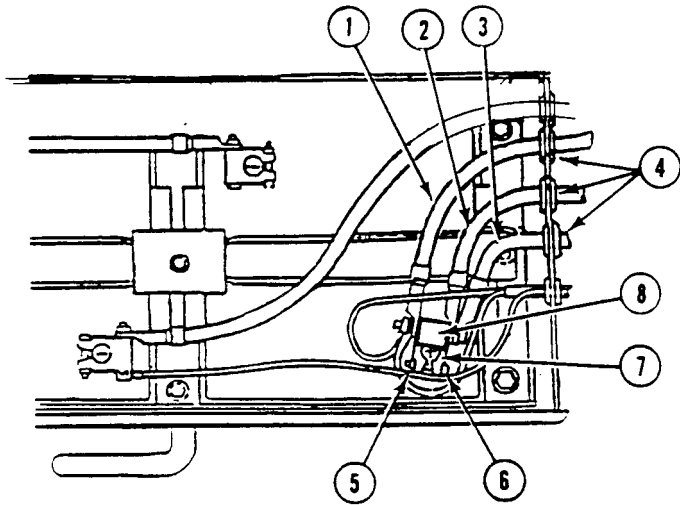

REPLACE BATTERY LEADS AND TERMINALS (LEFT SIDE) (M1064A3 ONLY) —
Continued

0343 00

CLEANING

1. Clean battery terminal lugs, battery posts, grounding bracket on hull, and lead connectors with brush dipped in mixture of sodium bicarbonate and water. After foaming stops, flush parts with clean water. Dry with clean cloth.
2. Clean terminals and posts with battery wire brush.
3. Check leads. Replace worn leads and damaged connectors (WP 0382 00).

INSTALLATION**CAUTION**

Battery cells can be damaged if the batteries are hooked up incorrectly. Make sure batteries are hooked up correctly.

1. Place terminal lugs (1) on positive battery post (2) and negative battery post (3). Secure with two screws (4) and nuts (5).
2. Align jumper lead (6) on terminal lugs (1). Secure with two screws (7) and nuts (8).
3. Install circuit 779 lead (9), circuit 772 lead (10), circuit 778 lead (11), and new grommet (12) in battery compartment.
4. Install circuit 7 lead (13) and new grommet (14) in battery compartment.

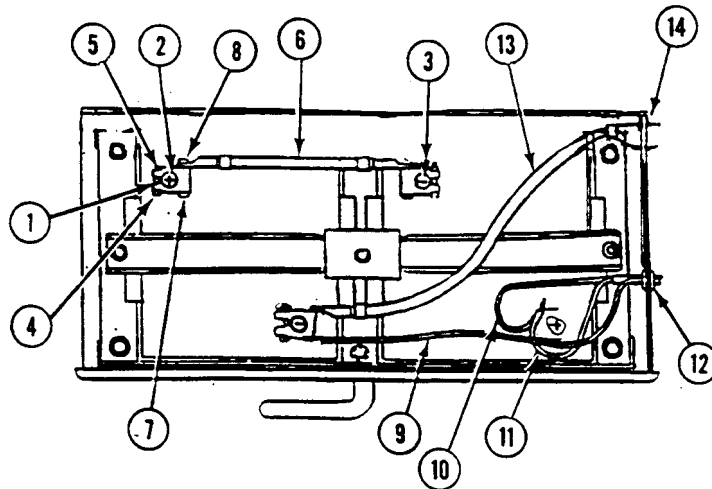

**REPLACE BATTERY LEADS AND TERMINALS (LEFT SIDE) (M1064A3 ONLY) —
Continued**

0343 00

5. Place terminal lug (15) on negative battery post (16) and secure with screw (17) and nut (18).
6. Align circuit 779 lead (9) on screw (19) in negative terminal lug (15).
7. Install circuit 7 lead (13) on screw (19) in negative terminal lug (15). Secure with nut (20).
8. Install new tiedown straps (21) on circuit 6P lead (22) and circuit 6N lead (23).
9. Align five clamps (24) on weldnuts and secure with new lockwashers (25) and screws (26).
10. Install circuit 6N lead (23) to shunt (27) and secure with new lockwasher (28) and screw (29).

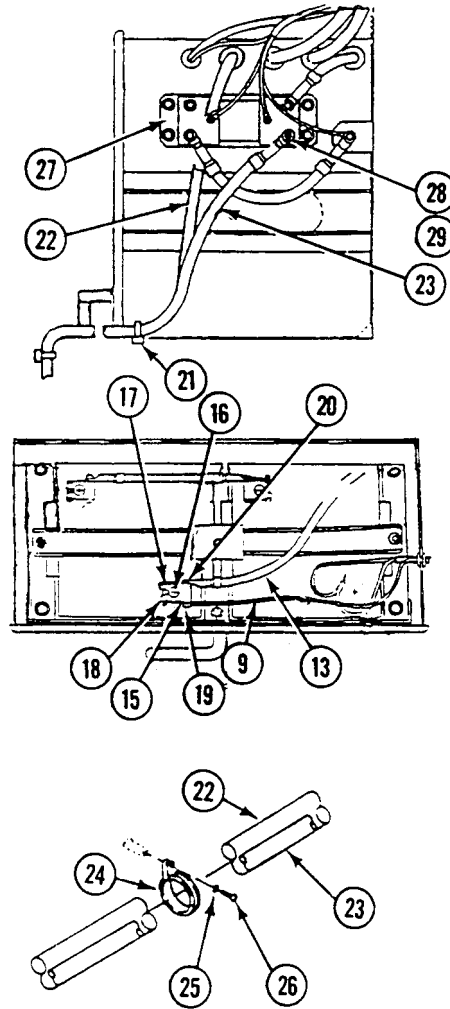

**REPLACE BATTERY LEADS AND TERMINALS (LEFT SIDE) (M1064A3 ONLY) —
Continued**

0343 00

11. Position terminal lug cover (1) and terminal lug (2) on positive battery terminal (3). Secure with screw (4) and nut (5).
12. Install circuit 6P lead (6), circuit 48 lead (7), circuit 6 lead (8), and new grommets (9) in battery compartment.
13. Install circuit 6P lead (6) followed by circuit 48 lead (7) on screw (10) in terminal lug (2).
14. Install circuit 6 lead (8), circuit 778 lead (11), and circuit 772 lead (12) on terminal lug (2). Secure with nut (13).
15. Coat tops of terminal lugs with grease.
16. Close battery drawer (14).

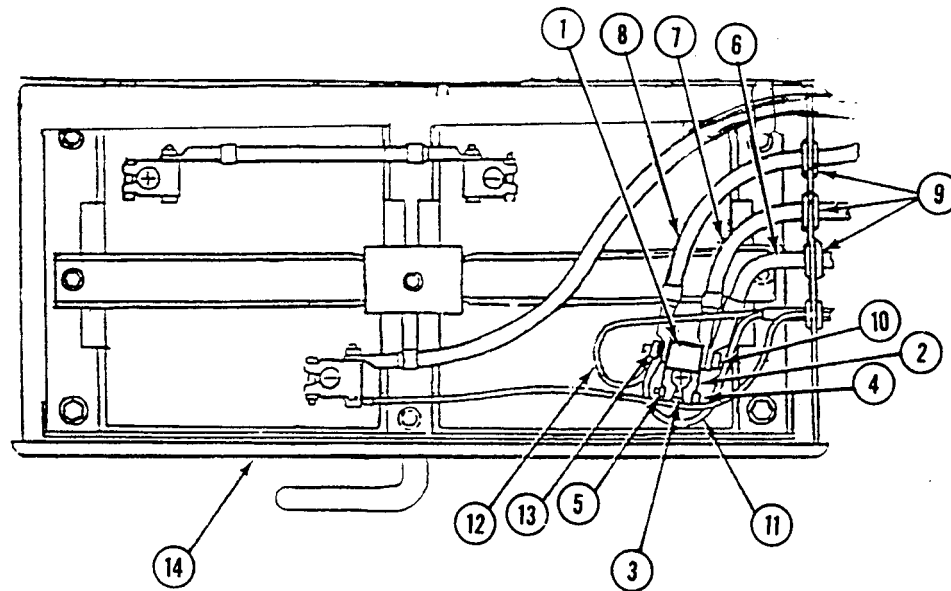

FOLLOW-THROUGH STEPS

1. Install battery leads (right side) (WP 0344 00).
2. Install front floor plates (WP 0543 00).
3. Connect battery ground strap (WP 0337 00).
4. Turn MASTER SWITCH ON. Check BATT- GEN gage on instrument panel. Gage should read in green or yellow zone (see your -10).
5. Start engine (see your -10).
6. Raise and lock ramp (see your -10).
7. Stop engine (see your -10).

END OF TASK

REPLACE BATTERY LEADS AND TERMINALS (RIGHT SIDE) (M1064A3 ONLY)

0344 00

THIS WORK PACKAGE COVERS:

- Removal (page 0344 00-1).
- Cleaning and Inspection (page 0344 00-3).
- Installation (page 0344 00-4).

INITIAL SETUP:

Maintenance Level

Unit

References

See your -10

Tools and Special Tools

- General Mechanic's Tool Kit (WP 0926 00, Item 65)
- Battery Wire Brush (WP 0926 00, Item 10)
- Battery Terminal Puller (WP 0926 00, Item 37)

Equipment Condition

- Engine stopped (see your -10)
- Carrier blocked (see your -10)
- Ramp lowered (see your -10)
- Battery ground strap disconnected (WP 0337 00)
- Front floor plates removed (WP 0543 00)
- Battery leads (left side) removed (WP 0343 00)
- Battery box cover/seat removed (see your -10)

Materials/Parts

- Grease (WP 0928 00, Item 12)
- Sodium bicarbonate (WP 0928 00, Item 60)
- Grommet (2)
- Tiedown strap

Personnel Required

Unit Mechanic

REMOVAL

WARNING



Battery posts and cables touched by metal objects can short circuit and burn you. Do not wear jewelry, necklaces, or watches when working on the electrical system. Keep tools away from posts, wires, and terminals.

WARNING



Gas from batteries can explode and injure you. Do not allow sparks near batteries. Battery acid can burn or blind you. Do not get acid on your skin or eyes. ALWAYS disconnect ground lead first and connect it last.

CAUTION

Do not start carriers while batteries are disconnected. Starting engine with outside power while batteries are disconnected will damage electrical components in the regulator.

1. Remove circuit 6N lead (1) or 6P lead (2) as follows:

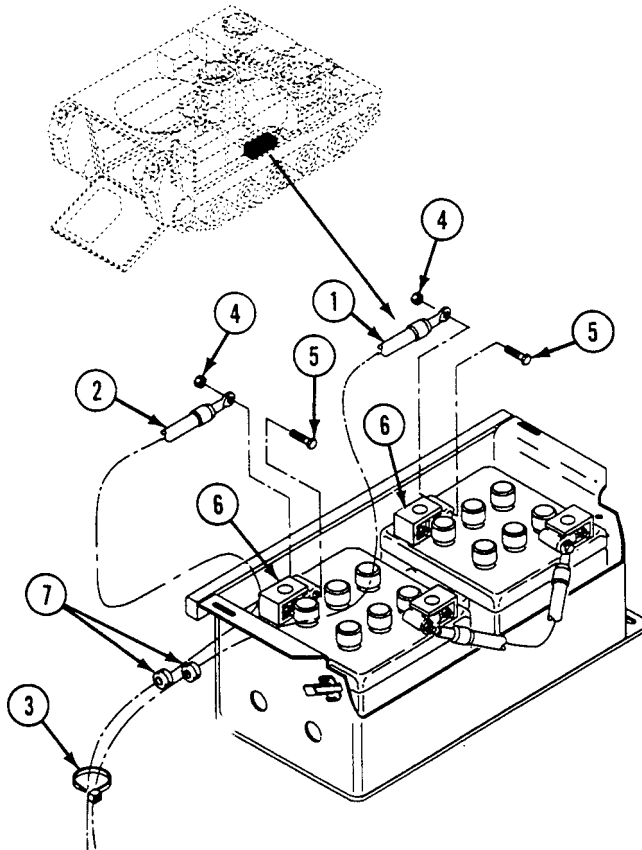

- a. Remove tiedown strap (3) from circuit 6N lead (1) and 6P lead (2).
- b. Remove nut (4), screw (5), and lead (1) or (2) from terminal lug (6).
- c. Remove lead and grommet (7) from battery compartment. Discard grommet.

**REPLACE BATTERY LEADS AND TERMINALS (RIGHT SIDE) (M1064A3 ONLY) —
Continued**

0344 00

2. Remove two nuts (1), screws (2), and jumper lead (3) from two terminal lugs (4).
3. Loosen nuts (5) on screws (6) and remove terminal lugs (4) and terminal covers (7) from battery posts. Use battery terminal puller.

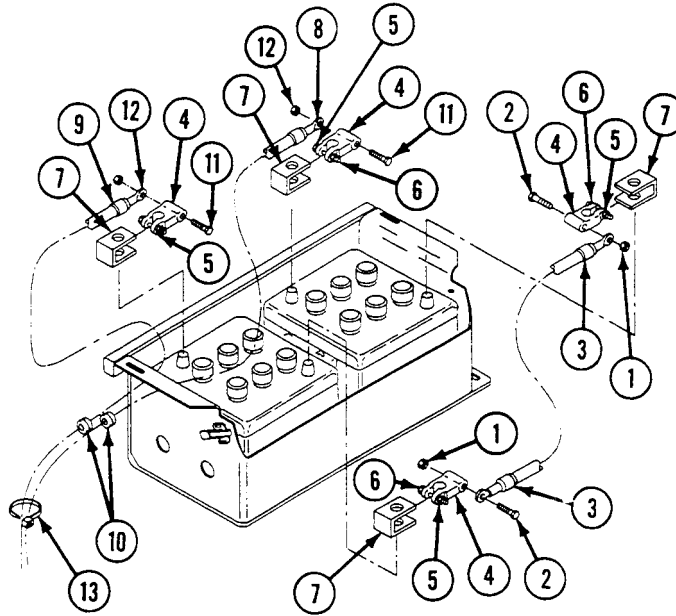

CLEANING

1. Clean battery terminal lugs, battery posts, grounding bracket on hull, and lead connectors with brush dipped in mixture of sodium bicarbonate and water. After foaming stops, flush parts with clean water. Dry with clean cloth.
2. Clean terminals and posts with battery wire brush.
3. Check leads. Replace worn leads and damaged connectors (WP 0382 00).

REPLACE BATTERY LEADS AND TERMINALS (RIGHT SIDE) (M1064A3 ONLY) —
Continued

0344 00

INSTALLATION**CAUTION**

Battery cells can be damaged if the batteries are hooked up incorrectly. Make sure batteries are hooked up correctly.

1. Place terminal covers (7) and terminal lugs (4) on battery. Secure with screws (6) and nuts (5).
2. Place jumper lead (3) on terminal lugs (4). Secure with two screws (2) and nuts (1).
3. Install circuit 6N lead (8) or 6P lead (9) as follows:
 - a. Install new grommet (10) in battery box. Route lead 6N (8) or 6P (9) through grommet into battery box.
 - b. Place lead (8) or (9) on terminal lugs (4) and secure with screw (11) and nut (12).
 - c. Secure leads 6N (8) and 6P (9) with new tiedown strap (13).
4. Coat tops of four battery terminal lugs with grease.

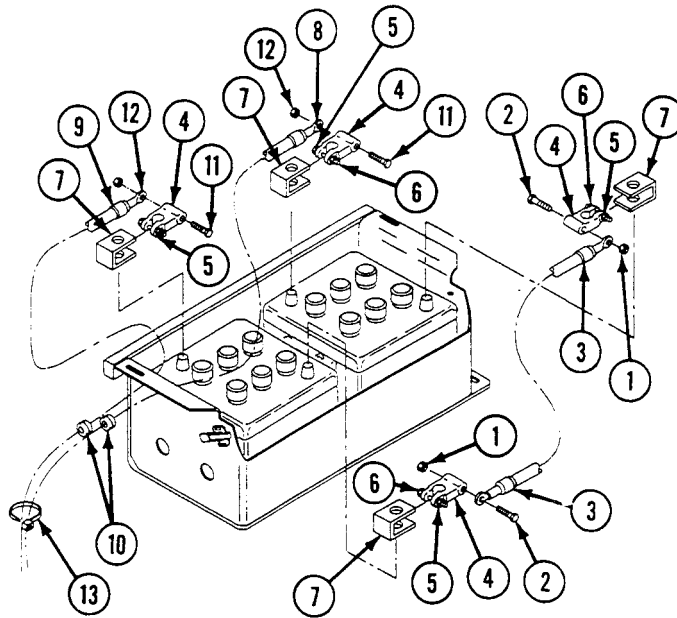

REPLACE BATTERY LEADS AND TERMINALS (RIGHT SIDE) (M1064A3 ONLY) —**0344 00**

Continued**FOLLOW-THROUGH STEPS**

1. Install battery box cover/seat (see your -10).
2. Install battery leads (left side) (WP 0343 00).
3. Install front floor plates (WP 0543 00).
4. Connect battery ground strap (WP 0337 00).
5. Turn MASTER SWITCH ON. Check BATT- GEN gage on instrument panel. Gage should read in green or yellow zone (see your -10).
6. Start engine (see your -10).
7. Raise and lock ramp (see your -10).
8. Stop engine (see your -10).

END OF TASK

REPLACE BATTERY LEADS AND TERMINALS (M58 ONLY)

0345 00

THIS WORK PACKAGE COVERS:

- Removal (page 0345 00-1).
 - Cleaning and Inspection (page 0345 00-3).
 - Installation (page 0345 00-4).
-

INITIAL SETUP:

Maintenance Level

Unit

References

See your -10

Tools and Special Tools

- General Mechanic's Tool Kit (WP 0926 00, Item 65)
- Battery Wire Brush (WP 0926 00, Item 10)
- Battery Terminal Puller (WP 0926 00, Item 37)

Equipment Condition

- Engine stopped (see your -10)
- Carrier blocked (see your -10)
- Ramp lowered (see your -10)
- Battery ground strap disconnected (WP 0337 00)
- Battery access cover removed (see your -10)

Materials/Parts

- Grease (WP 0928 00, Item 12)
- Sodium bicarbonate (WP 0928 00, Item 60)
- Grommet (5)

Personnel Required

Unit Mechanic

REMOVAL

WARNING

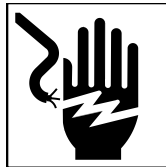

Battery posts and cables touched by metal objects can short circuit and burn you. Do not wear jewelry, necklaces, or watches when working on electrical system. Keep tools away from posts, wires, and terminals.

WARNING



Gas from batteries can explode and injure you. Do not allow sparks near batteries. Battery acid can blind or burn you. Do not get acid on your skin or into your eyes.

REPLACE BATTERY LEADS AND TERMINALS (M58 ONLY) — Continued

0345 00

1. Remove cable mounting nuts (1) and bolts (2) from each battery terminal adapter (3) on four batteries (4)(5)(6)(7).
2. Remove two battery positive-to-negative cables (8) and (9) from battery box.
3. Remove STE/ICE circuit 779 lead (10) from battery box.
4. Remove vehicle power cable (11), shunt cable (12), smoke obscurant system master power relay lead 6W21 (13), and STE/ICE circuit 772/778 leads (14) from battery box.
5. Remove positive communication power cable (15) and negative communication power cable (16) from battery box.
6. Remove one battery positive-to-positive cable (17) and one battery negative-to-negative cable (18) from battery box.

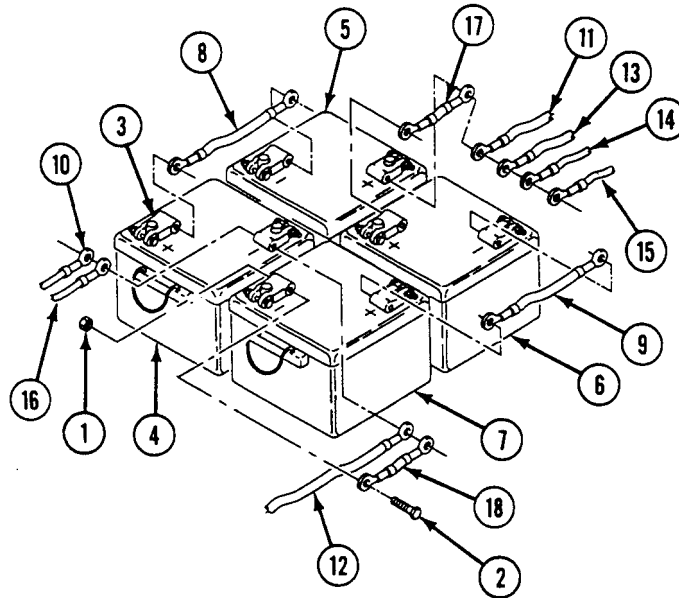

7. Remove used grommets (1) from battery box. Discard grommets.
8. Loosen nuts (2) on screws (3), and remove terminal adapters (4) and covers (5) from battery posts. Use battery terminal puller.

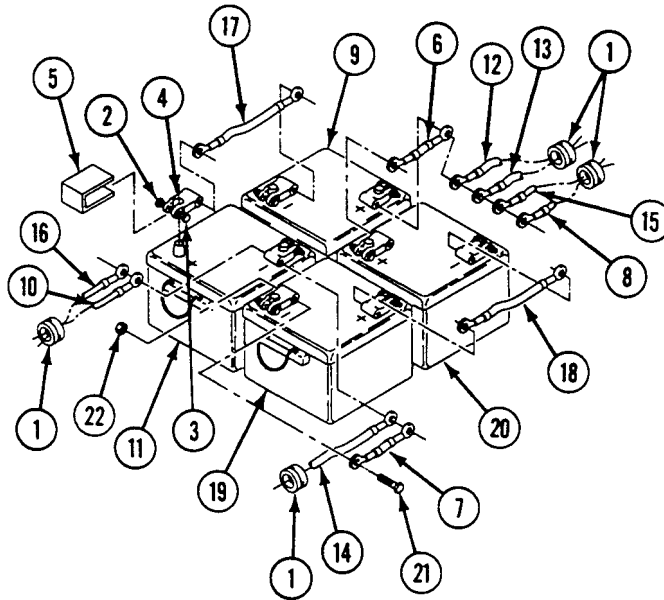

CLEANING

1. Clean battery covers, terminals, battery posts, and lead connectors with brush dipped in mixture of sodium bicarbonate and water. After foaming stops, flush parts with clean water. Dry with clean cloth.
2. Clean terminals and posts with battery wire brush.

INSTALLATION

1. Install terminal covers (5) and terminal adapters (4) on battery posts. Secure with screws (3) and nuts (2).
2. Install new grommets (1) in battery box.
3. Install one battery positive-to-positive cable (6) and one battery negative-to-negative cable (7) in battery box.
4. Install one positive communication cable (8) through front opening in battery box to positive terminal on battery (9).
Install one negative communication cable (10) through rear opening in battery box to negative terminal on battery (11).
5. Insert end of vehicle power cable circuit 6 (12) and end of smoke obscurant system master power relay lead 6W21 (13) through front opening in battery box to positive terminal of battery (9) and vehicle shunt cable circuit 7 (14) through rear opening in battery box to negative terminal of battery (11).
6. Insert ends of STE/ICE leads circuit 772 and 778 (15) through front opening in battery box and route to positive terminal of battery (9).
7. Insert end of STE/ICE circuit 779 lead (16) through rear opening in battery box and route to negative terminal of battery (11).
8. Install battery cables (17) and (18) on inward side of and between positive and negative terminal adapters (6) on batteries (9) and (19), (11) and (20).
9. Secure leads to each battery terminal adapter (4) on batteries (9)(11)(19)(20) with cable mounting bolts (21) and nuts (22).
10. Coat tops of eight battery terminal adapters with grease.

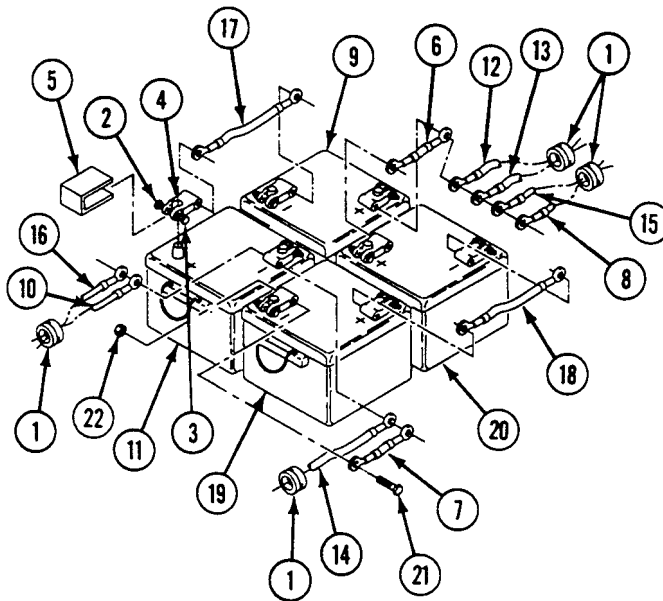

FOLLOW-THROUGH STEPS

1. Connect battery ground strap (WP 0337 00).
2. Install battery access cover (see your -10).
3. Start engine (see your -10).
4. Raise and lock ramp (see your -10).
5. Stop engine (see your -10).

END OF TASK

REPLACE BATTERIES AND RETAINERS (M113A3 AND M1059A3 ONLY)

0346 00 ■

THIS WORK PACKAGE COVERS:

- Removal (page 0346 00-1).
- Cleaning and Inspection (page 0346 00-3).
- Installation (page 0346 00-4).

INITIAL SETUP:

Maintenance Level

Unit

Tools and Special Tools

General Mechanic's Tool Kit (WP 0926 00, Item 65)

Materials/Parts

- Bituminous coating compound (WP 0928 00, Item 13)
- Epoxy coating kit (WP 0928 00, Item 30)
- Sodium bicarbonate (WP 0928 00, Item 60)
- Locknut (2)
- Locknut (4)

Personnel Required

- Unit Mechanic
- Helper (H)

References

- See your -10
- TM 9-6140-200-14

Equipment Condition

- Engine stopped (see your -10)
- Carrier blocked (see your -10)
- Ramp lowered (see your -10)
- Spall liners opened (see your -10)
- Battery ground strap disconnected (WP 0337 00)
- Battery access cover removed (see your -10)
- Battery terminals removed (WP 0340 00)

REMOVAL

NOTE

Four batteries and four retainers are replaced the same way.

1. Remove bolt (1), washer (2), and clamp (3) from two retainers (4).
2. Remove two locknuts (5), washers (6), and retainers (4) from two bolts (7). Discard locknuts.
3. Turn bolts (7) to align with slot in frame (8). Remove bolts from frame.

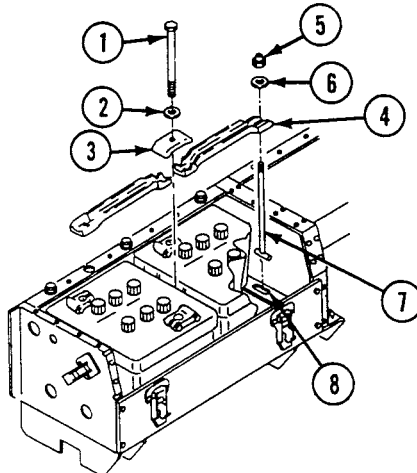

WARNING

Electrolyte and battery corrosion can cause injury to you. Wear safety goggles and gloves. If electrolyte or battery corrosion contacts the eyes, skin, or clothing, flush immediately with large amounts of cold water. In case of eye or skin contact, see a doctor immediately.

WARNING

Battery is heavy and can cause back injury if handled improperly. Be sure to have helper assist you to remove and replace battery. Battery weighs about 75 lb (34 kg).

CAUTION

Be careful. Do not hit side of carrier. You could crack the case. Set battery down gently on a board.

NOTE

On newer models, there are screws and washers securing the front plate to the battery box.

REPLACE BATTERIES AND RETAINERS (M113A3 AND M1059A3 ONLY) —
Continued

0346 00 ■

4. Remove four screws (1), eight washers (2), four locknuts (3) and front plate (4) from battery box (5). Discard locknuts (on older models only).
5. Remove batteries (6) from battery box (5). Lift battery by carrying handles built into each battery. Have helper assist.

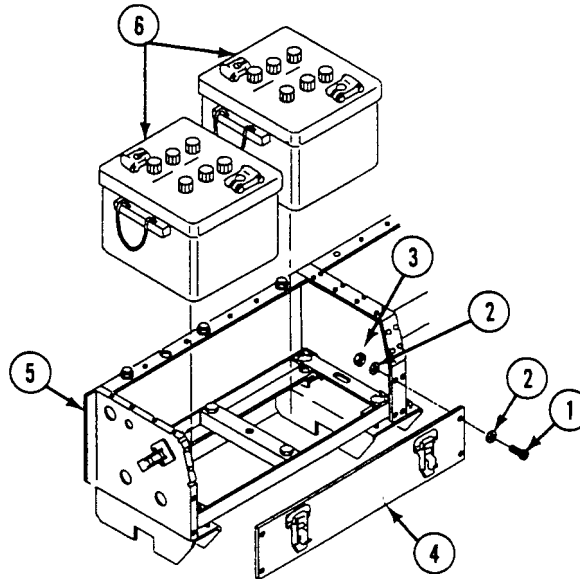
**CLEANING AND INSPECTION**

WARNING



Battery posts and cables touched by metal objects can short circuit and burn you. Do not wear jewelry, necklaces, or watches when working on the electrical system. Keep tools away from posts, wires, and terminals.

1. Clean battery with nonmetallic brush dipped in mixture of sodium bicarbonate and water. After foaming stops, flush battery with clean water. Dry with clean cloth.
2. Clean retainers and parts by soaking in mixture of sodium bicarbonate and water. Dry parts and apply coating listed in order of preference.
3. See TM 9-6140-200-14 to service batteries.

INSTALLATION**WARNING**

Battery is heavy and can cause back injury if handled improperly. Be sure to have helper assist you to remove and replace battery. Battery weighs about 75 lb (34 kg).

CAUTION

Place batteries with positive (+) and negative (-) terminals as shown in diagram below. Damage to components will occur if batteries are hooked up wrong.

1. Place batteries (6) in battery box (5).

NOTE

On newer models, there are screws and washers securing the front plate to the battery box.

2. Install front plate (4) on battery box (5). Secure with four screws (1), eight washers (2), and four new locknuts (3).

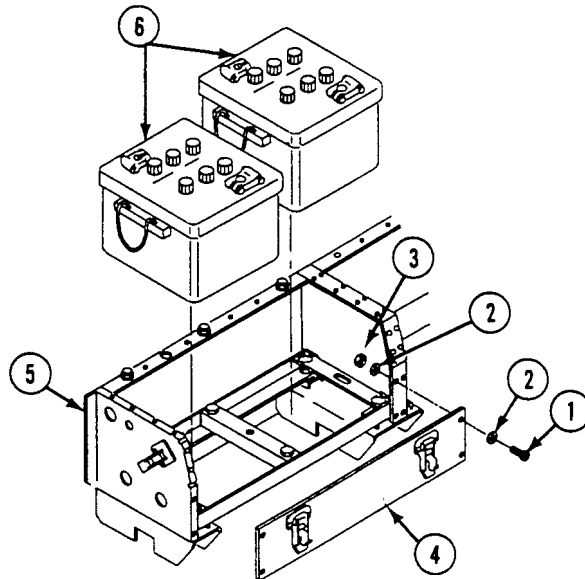

REPLACE BATTERIES AND RETAINERS (M113A3 AND M1059A3 ONLY) —
Continued

0346 00 ■

3. Install two bolts (1) in slots of battery frame (2). Turn bolts to secure.
4. Install two retainers (3) on two bolts (1). Secure with two washers (4) and new locknuts (5).
5. Install clamp (6) on two retainers (3). Secure with washer (7) and bolt (8).

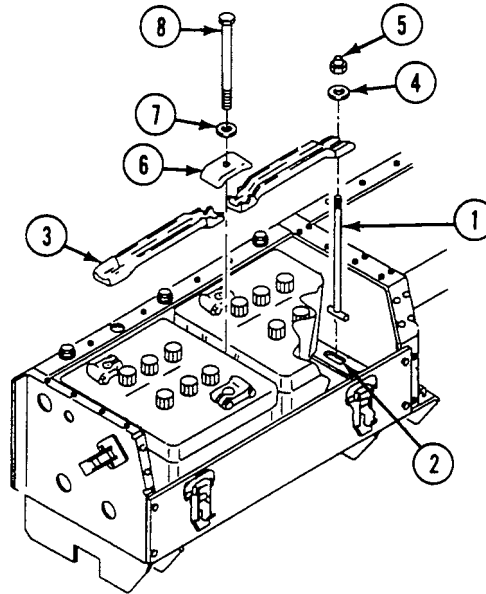
**FOLLOW-THROUGH STEPS**

1. Install battery terminals (WP 0340 00).
2. Install battery access cover (see your -10).
3. Connect battery ground strap (WP 0337 00).
4. Turn MASTER SWITCH ON to check that batteries are installed right. MASTER SWITCH ON light should come on (see your -10).
5. Start engine (see your -10).
6. Raise and lock ramp (see your -10).
7. Stop engine (see your -10).

END OF TASK

REPLACE BATTERIES AND RETAINERS (M577A3 AND M1068A3 ONLY)

0347 00

THIS WORK PACKAGE COVERS:

- Removal (page 0347 00-1).
- Cleaning and Inspection (page 0347 00-3).
- Installation (page 0347 00-3).

INITIAL SETUP:

Maintenance Level

Unit

References

See your -10
TM 9-6140-200-14

Tools and Special Tools

General Mechanic's Tool Kit (WP 0926 00, Item 65)

Materials/Parts

Bituminous coating compound (WP 0928 00, Item 13)

Epoxy coating kit (WP 0928 00, Item 30)

Sodium bicarbonate (WP 0928 00, Item 60)

Locknut (4)

Personnel Required

Unit Mechanic

Helper (H)

Equipment Condition

Engine stopped (see your -10)

Carrier blocked (see your -10)

Ramp lowered (see your -10)

Battery ground lead disconnected (WP 0338 00)

Battery terminals removed (WP 0341 00)

REMOVAL

NOTE

Four batteries and four retainers are replaced the same way.

1. Remove bolt (1), washer (2), and clamp (3) from two retainers (4).
2. Remove two locknuts (5), washers (6), and retainers (4) from two bolts (7). Discard locknuts.
3. Turn bolts (7) to align with slot in frame (8). Remove bolts from frame.

WARNING

Electrolyte and battery corrosion can cause injury to you. Wear safety goggles and gloves. If electrolyte or battery corrosion contacts the eyes, skin, or clothing, flush immediately with large amounts of cold water. In case of eye or skin contact, see a doctor immediately.

WARNING

Battery is heavy and can cause back injury if handled improperly. Be sure to have helper assist you to remove and replace battery. Battery weighs about 75 lb (34 kg).

CAUTION

Be careful. Do not hit side of carrier. You could crack the case. Set battery down gently on a board.

4. Remove batteries (9) from frame (8) and battery box (10). Lift battery by carrying handles built into each battery. Have helper assist.

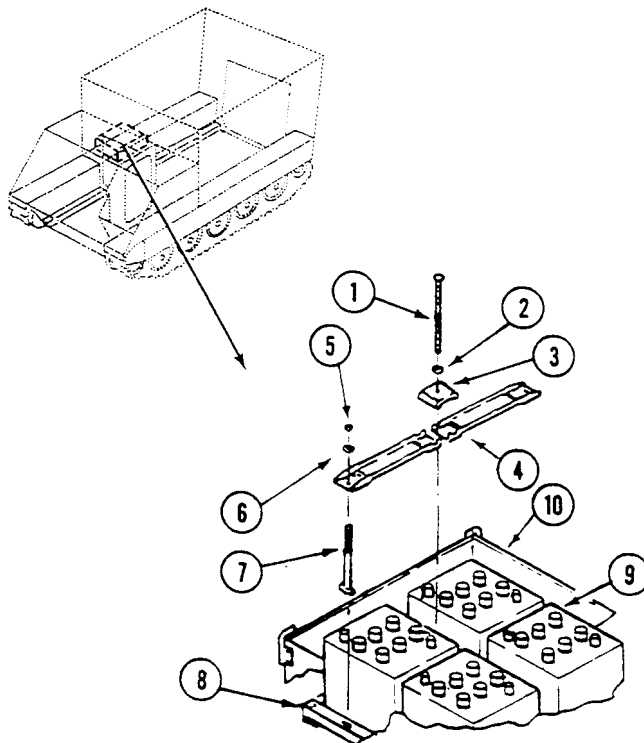

CLEANING**CLEANING AND INSPECTION****WARNING**

Battery posts and cables touched by metal objects can short circuit and burn you. Do not wear jewelry, necklaces, or watches when working on the electrical system. Keep tools away from posts, wires, and terminals.

1. Clean battery with nonmetallic brush dipped in mixture of sodium bicarbonate and water. After foaming stops, flush battery with clean water. Dry with clean cloth.
2. Clean retainers and parts by soaking in mixture of sodium bicarbonate and water. Dry parts and apply coating listed in order of preference.
3. See TM 9-6140-200-14 to service batteries.

INSTALLATION**WARNING**

Battery is heavy and can cause back injury if handled improperly. Be sure to have helper assist you to remove and replace battery. Battery weighs about 75 lb (34 kg).

CAUTION

Place batteries with positive (+) and negative (-) terminals as shown in diagram below. Damage to components will occur if batteries are hooked up wrong.

1. Place batteries (1) on frame (2) in battery box (3).

2. Install two bolts (4) in slots of battery frame (2). Turn bolts to secure.
3. Install two retainers (5) on two bolts (4). Secure with two washers (6) and new locknuts (7).
4. Install clamp (8) on two retainers (5). Secure with washer (9) and bolt (10).

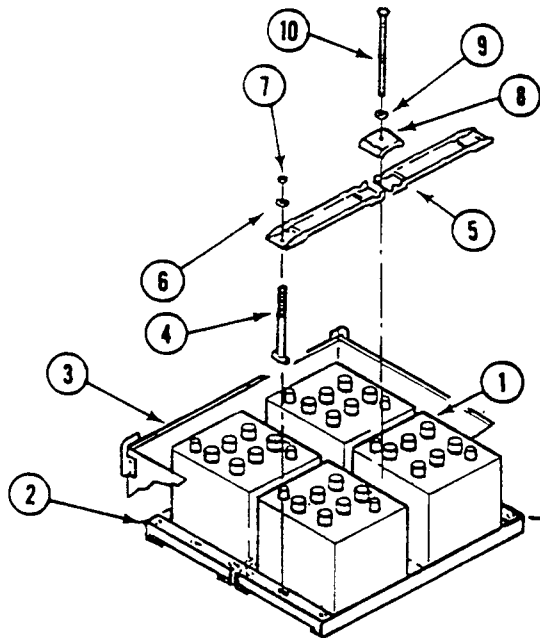
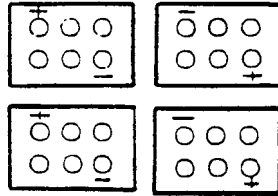

FOLLOW-THROUGH STEPS

1. Install battery terminals (WP 0341 00).
2. Connect battery ground lead (WP 0338 00).
3. Turn MASTER SWITCH ON to check that batteries are installed right. MASTER SWITCH ON light should come on (see your -10).
4. Start engine (see your -10).
5. Raise and lock ramp (see your -10).
6. Stop engine (see your -10).

END OF TASK

REPLACE BATTERIES AND BATTERY BOX (M58 ONLY)

0348 00

THIS WORK PACKAGE COVERS:

- Removal (page 0348 00-1).
- Disassembly (page 0348 00-5).
- Cleaning and Inspection (page 0348 00-6).
- Assembly (page 0348 00-7).
- Installation (page 0348 00-8).

INITIAL SETUP:

Maintenance Level

Unit

Personnel Required

Unit Mechanic
Helper

Tools and Special Tools

- General Mechanic's Tool Kit (WP 0926 00, Item 65)
- Portable electric drill (WP 0926 00, Item 19)
- Blind hand riveter (WP 0926 00, Item 44)

References

See your -10
TM 9-6140-200-14

Materials/Parts

- Adhesive (WP 0928 00, Item 4)
- Bituminous coating compound (WP 0928 00, Item 13)
- Epoxy coating kit (WP 0928 00, Item 30)
- Sodium bicarbonate (WP 0928 00, Item 60)
- Locknut
- Lockwasher (4)
- Lockwasher (4)

Equipment Condition

- Engine stopped (see your -10)
- Carrier blocked (see your -10)
- Ramp lowered (see your -10)
- Battery ground leads disconnected (WP 0337 00)
- Battery leads and terminals removed (WP 0345 00)

REMOVAL

WARNING



Battery posts and cables touched by metal objects can short circuit and burn you. Do not wear jewelry, necklaces, or watches when working on electrical system. Keep tools away from posts, wires, and terminals.

WARNING



Gas from batteries can explode and injure you. Do not allow sparks near batteries. Battery acid can blind or burn you. Do not get acid on your skin or into your eyes.

1. Remove two bolts (1), washers (2), and clamps (3).
2. Remove four locknuts (4), washers (5), and battery retainers (6). Discard locknuts.

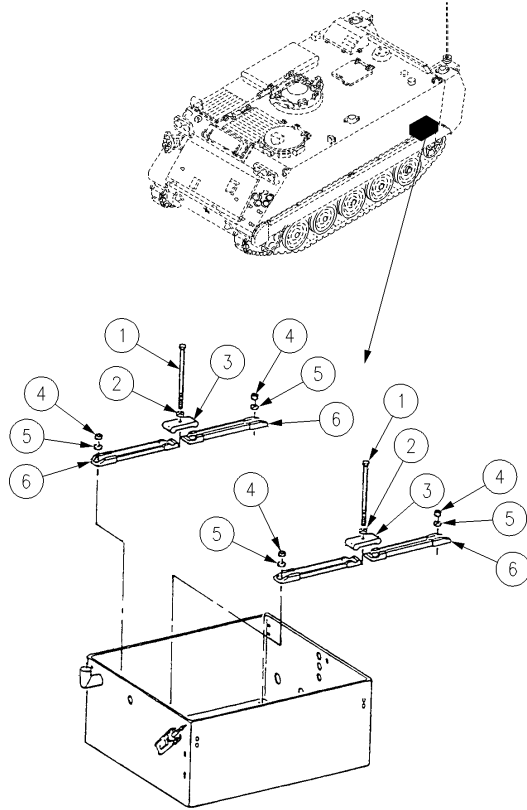

WARNING

Battery is heavy and can cause back injury if handled improperly. Be sure to have helper assist you to remove and replace battery. Battery weighs about 75 lb (34 kg).

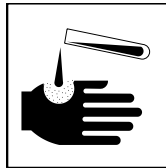
WARNING

Electrolyte and battery corrosion can cause injury to you. Wear safety goggles and gloves. If electrolyte or battery corrosion contacts the eyes, skin, or clothing, flush immediately with large amounts of cold water. In case of eye or skin contact, see a doctor immediately.

3. Remove four batteries.

■ REPLACE BATTERIES AND BATTERY BOX (M58 ONLY) — Continued

0348 00

4. Remove eight screws (1), washers (2), and resilient mounts (3) and lift two battery racks (4) out of battery box (5).
5. Remove battery box assembly support plate (6) from battery box (5). Remove four T-head bolts (7) from two battery racks (4).
6. Loosen battery box hose clamp (8) and detach nonmetallic hose (9) from vent (10).
7. Remove battery box (5) from mounting blocks (11).

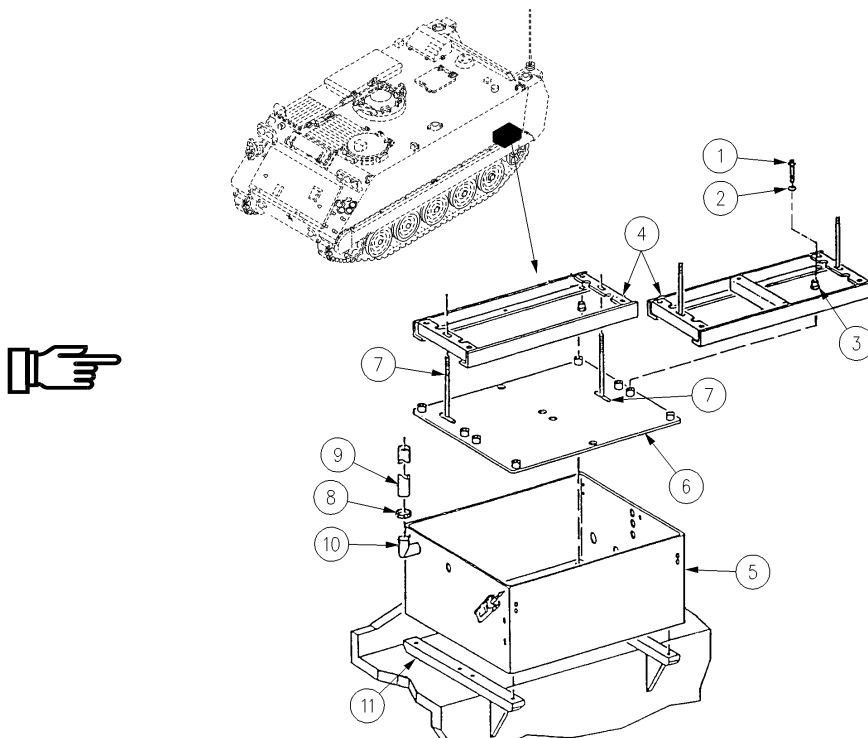

DISASSEMBLY

1. Remove four nuts (1), screws (2), lockwashers (3), and washers (4) holding two hooks (5) on battery box (6). Discard lockwashers.
2. Remove two hooks (5).
3. Remove four nuts (7), screws (8), lockwashers (9), washers (10), two clamping catches (11), and spacers (12) from battery box (6). Discard lockwashers.
4. Remove four caps (13), grommets (14), and one grommet (15) from battery box (6).
5. Remove four neoprene gaskets (16) from battery box cover (17).
6. Using a drill or chisel, remove solid rivet (18) and catch strike (19) from battery box cover (17).

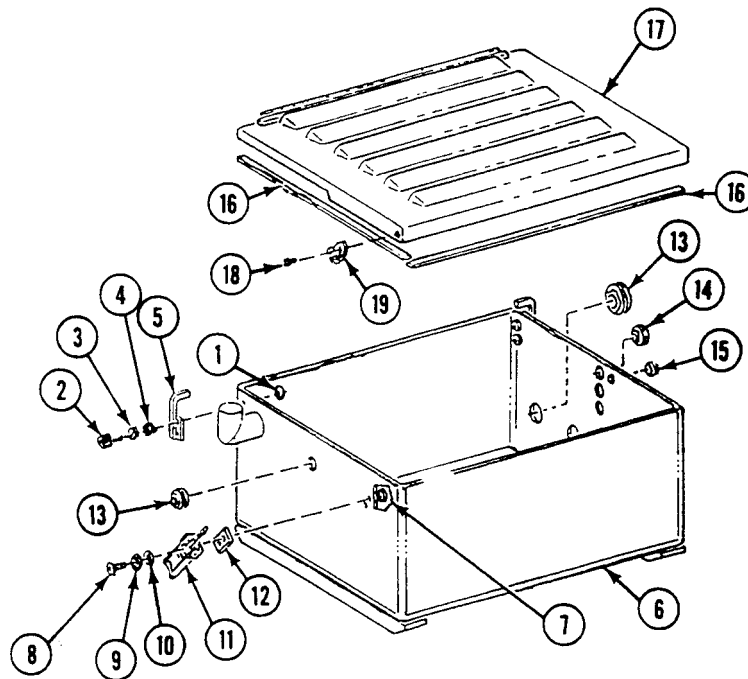

CLEANING

WARNING

Battery posts and cables touched by metal objects can short circuit and burn you. Do not wear jewelry, necklaces, or watches when working on the electrical system. Keep tools away from posts, wires, and terminals.

1. Clean battery with nonmetallic brush dipped in mixture of sodium bicarbonate and water. After foaming stops, flush battery with clean water. Dry with clean cloth.
2. Clean battery box retainers and parts by soaking in mixture of sodium bicarbonate and water. Dry parts and apply coating listed in order of preference.
3. See TM 9-6140-200-14 to service batteries.

ASSEMBLY

1. Install four caps (13), grommets (14), and one grommet (15) in battery box (6) openings.
2. Install two spacers (12) and clamping catches (11), four washers (10), new lockwashers (9), screws (8), and nuts (7) on battery box (6).
3. Install two hooks (5), four washers (4), lockwashers (3) screws (2), and nuts (1) on battery box (6).
4. Using rivet tool, attach solid rivet (18) and catch strike (19) to battery box cover (17).
5. Apply adhesive to four neoprene gaskets (16) and attach gaskets to battery box cover (17).

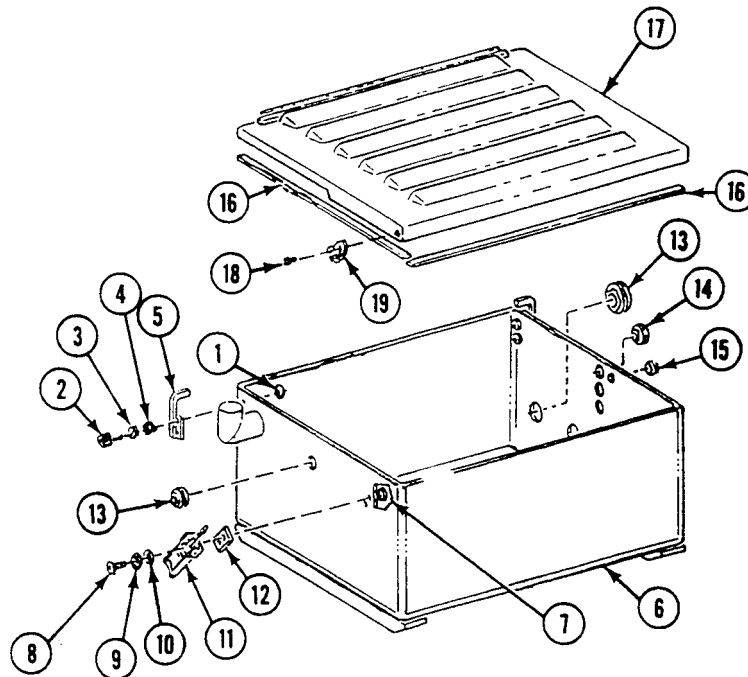

INSTALLATION

1. Align battery box (1) on two mounting blocks (2).
2. Install battery box assembly support plate (3) in battery box (1). Align mounting holes with battery box (1) mounting holes.
3. Install four T-head bolts (4) on two battery racks (5).
4. Install eight resilient mounts (6) and two battery racks (5) in battery box (1). Secure with eight washers (7) and screws (8).
5. Place clamp (9) on nonmetallic hose (10) and attach hose to vent (11). Tighten clamp (9).

WARNING



Battery is heavy and can cause back injury if handled improperly. Be sure to have helper assist you to remove and replace battery. Battery weighs about 75 lb (34 kg).

6. Install four batteries in battery box (1).
7. Install four battery retainers (12) on two battery racks (5). Secure with four washers (13) and new locknuts (14).
8. Install two battery clamps (15), washers (16), and bolts (17) on two battery racks (5).

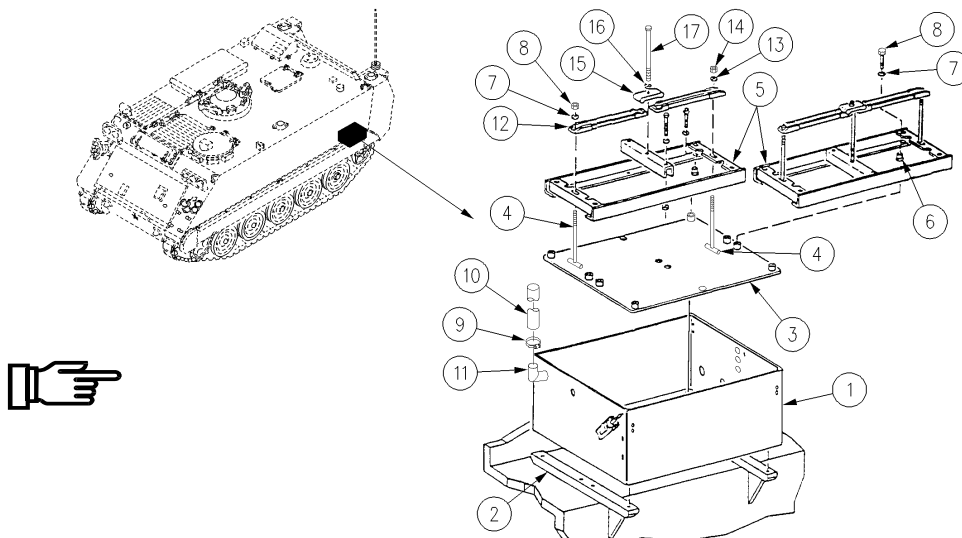

FOLLOW-THROUGH STEPS

1. Install battery leads and terminals (WP 0345 00).
2. Install battery ground leads (WP 0337 00). ■
3. Start engine (see your -10).
4. Raise and lock ramp (see your -10).
5. Stop engine (see your -10).

END OF TASK

REPLACE BATTERIES AND RETAINERS (M1064A3 ONLY)

0349 00

THIS WORK PACKAGE COVERS:

- Removal (page 0349 00-2).
- Cleaning and Inspection (page 0349 00-4).
- Installation (page 0349 00-5).

INITIAL SETUP:

Maintenance Level

Unit

References

See your -10
TM 9-6140-200-14

Tools and Special Tools

- General Mechanic's Tool Kit (WP 0926 00, Item 65)
- Battery Wire Brush (WP 0926 00, Item 10)

Materials/Parts

- Epoxy coating kit (WP 0928 00, Item 30)
- Sodium bicarbonate (WP 0928 00, Item 60)
- Wiping rag (WP 0928 00, Item 65)

Equipment Condition

- Engine stopped (see your -10)
- Battery leads disconnected and terminal lugs removed (left side) (WP 0343 00)
- Battery leads disconnected and terminal lugs removed (right side) (WP 0344 00)

Personnel Required

- Unit Mechanic
 - Helper (H)
-

REMOVAL

CAUTION

Do not start carriers while batteries are disconnected. Starting engine with outside power while batteries are disconnected will damage electrical components in the regulator.

NOTE

Procedures are the same for removing left and right side. Access is different.

For right side, Remove Battery Box Cover/Seat See your -10

For left side, Open Battery Drawer See your -10

1. Remove bolt (1), washer (2), and clamp (3) from two retainers (4).
2. Remove two nuts (5), washers (6), and retainers (4) from two hooks (7). Remove hooks from frame (8).

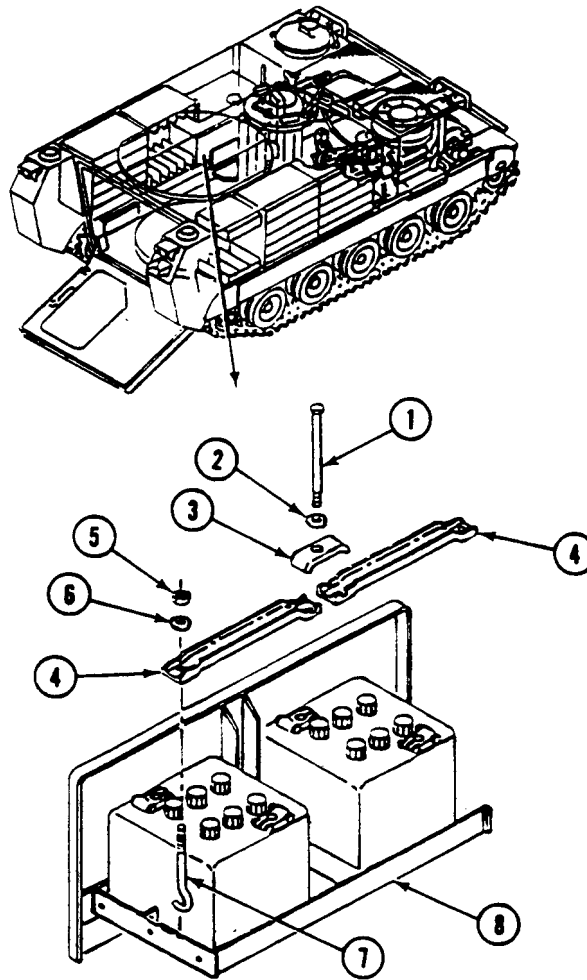

WARNING

Electrolyte and battery corrosion can cause injury to you. Wear safety goggles and gloves. If electrolyte or battery corrosion contacts the eyes, skin, or clothing, flush with large amounts of cold water and see a doctor immediately.

WARNING

Battery is heavy and can cause back injury if handled improperly. Be sure to have helper assist to remove battery. Battery weighs about 75 lb (34 kg).

CAUTION

Be careful. Do not hit side of carrier. You could crack the case. Set battery down gently on a board.

3. Remove batteries (1) from battery box (2). Lift battery by carrying handles built into each battery.

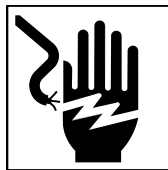
CLEANING**CLEAN AND INSPECT****WARNING**

Battery posts and cables touched by metal objects can short circuit and burn you. Do not wear jewelry, necklaces, or watches when working on the electrical system. Keep tools away from posts, wires, and terminals.

1. Clean battery with nonmetallic brush dipped in mixture of sodium bicarbonate and water. After foaming stops, flush battery with clean water. Dry with clean cloth.
2. Clean retainers and parts by soaking in mixture of sodium bicarbonate and water. Dry parts and apply epoxy coating.
3. See TM 9-6140-200-14 to service batteries.

INSTALLATION**WARNING**

Battery is heavy and can cause back injury if handled improperly. Be sure to have helper assist to install battery. Battery weighs about 75 lb (34 kg).

CAUTION

Place batteries with positive (+) and negative (-) terminals as shown in diagram. Damage to components will occur if batteries are hooked up wrong.

1. Place batteries (1) in battery box (2).
2. Place hooks (3) in battery frame (4).
3. Place two retainers (5) on two hooks (3). Secure with two washers (6) and nuts (7).
4. Place clamp (8) on two retainers (5). Secure with washer (9) and bolt (10).

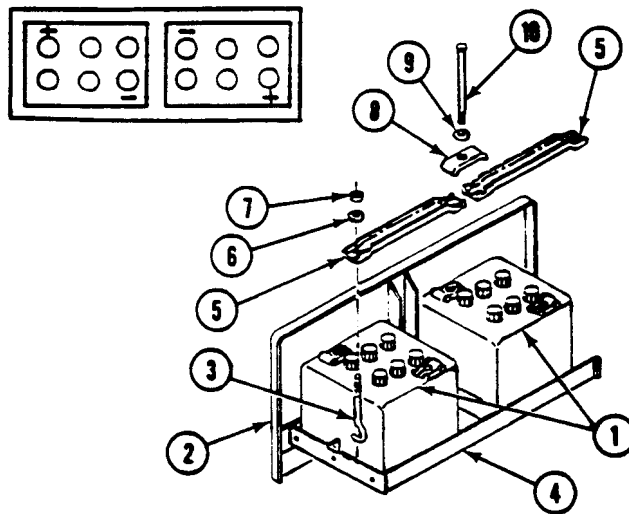
**FOLLOW-THROUGH STEPS**

1. Install terminal lugs and connect battery leads (left side) (WP 0343 00) and install terminal lugs and connect battery leads (right side) (WP 0343 00).
2. Turn MASTER SWITCH ON to check that battery is installed correctly. MASTER SWITCH ON light should come on (see your -10).
3. Start engine (see your -10).
4. Raise and lock ramp (see your -10).
5. Stop engine (see your -10).

END OF TASK

REPAIR BATTERY BOX (M113A3 AND M1059A3 ONLY)

0350 00 ■

THIS WORK PACKAGE COVERS:

- Removal (page 0350 00-1).
 - Cleaning and Inspection (page 0350 00-3).
 - Installation (page 0350 00-4).
-

INITIAL SETUP:

Maintenance Level

Unit

Personnel Required

Unit Mechanic

Tools and Special Tools

- General Mechanic's Tool Kit (WP 0926 00, Item 65)
- Socket Wrench Set (WP 0926 00, Item 72)
- Torque Wrench (WP 0926 00, Item 80)

References

See your -10

Materials/Parts

- Bituminous coating compound (WP 0928 00, Item 13)
- Epoxy coating kit (WP 0928 00, Item 30)
- Sodium bicarbonate (WP 0928 00, Item 60)
- Grommet (3)
- Locknut (6)
- Mount (4)

Equipment Condition

- Engine stopped (see your -10)
 - Carrier blocked (see your -10)
 - Ramp lowered (see your -10)
 - Battery ground strap disconnected (WP 0337 00)
 - Battery access covers removed (see your -10)
 - Battery leads and terminals removed (WP 0340 00)
 - Batteries and retainers removed (WP 0346 00)
-

REMOVAL

NOTE

Both front and rear battery boxes are repaired the same way.

NOTE

Repair of the battery box is limited to replacement of channel dividers, frames, frame mounts, and latches.

NOTE

On newer models, there are screws and washers securing the front plate to the battery box.

1. Remove four screws (1), eight washers (2), four locknuts (3), and front plate (4) from battery box (5). Discard locknuts.

NOTE

Six latches are removed the same way. Two are located on the boxes. Four are located on the front plates.

2. Remove two locknuts (6), washers (7), screws (8), and latch (9) from box (5) or plate (4). Discard locknuts.

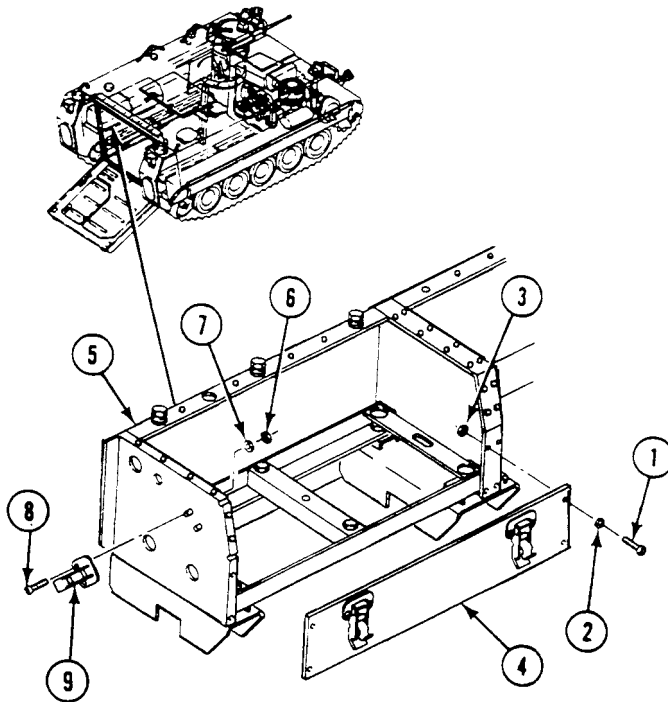

3. Remove two screws (1), washers (2), and channel divider (3) from battery box frame (4).
4. Remove four screws (5), eight washers (6), and battery box frame (4) with four frame mounts (7) from battery box support (8).
5. Remove four frame mounts (7) from battery box frame (4). Discard mounts.
6. Remove three nuts (9), six washers (10), three grommets (11), and screws (12) from rear of battery box (13). Discard grommets.
7. If damaged, remove rubber bumpers (14) from battery box (13). Discard bumpers.

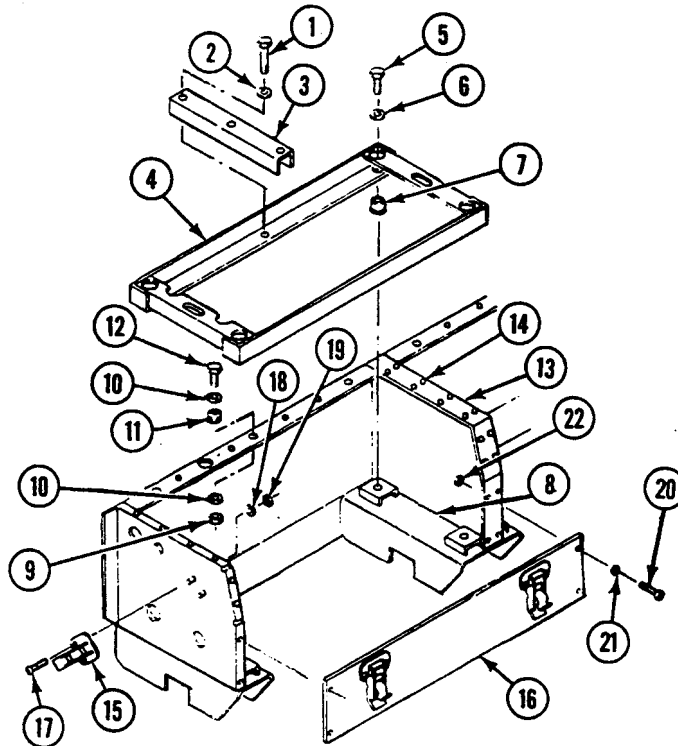

CLEANING AND INSPECTION

1. Clean battery box by soaking in mixture of sodium bicarbonate and water. Dry parts and apply coating.

INSTALLATION

1. If removed, install new rubber bumpers (14) on battery box (13).
2. Install three new grommets (11) in rear of battery box (13). Secure with three screws (12), six washers (10), and three nuts (9).
3. Install four new frame mounts (7) in battery box frame (4).
4. Install battery box frame (4) with frame mounts (7). Secure with four screws (5) and washers (6).
5. Install channel divider (3) on battery box frame (4). Secure with two screws (1) and washers (2). **TIGHTEN SCREWS TO 120-192 LB-IN (14-22 N·m) TORQUE.**

NOTE

Six latches are installed the same way.

6. Install latch (15) on battery box (13) or front plate (16). Secure with two screws (17), washers (18), and new locknuts (19).

NOTE

On newer models, there are screws and washers securing the front plate to the battery box.

7. Install front plate (16) on battery box (13). Secure with four screws (20), eight washers (21), and four new locknuts (22).

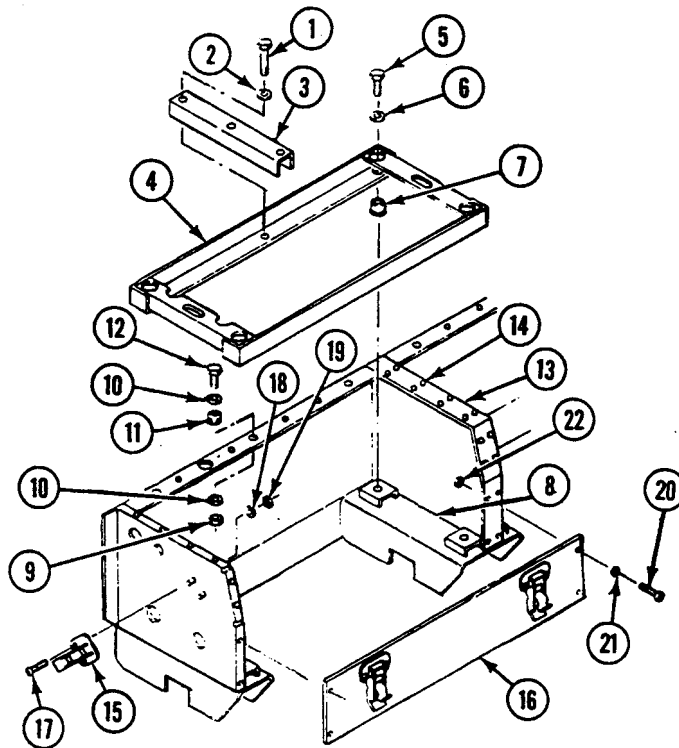

FOLLOW-THROUGH STEPS

1. Install batteries and retainers (WP 0346 00).
2. Install battery leads and terminals (WP 0340 00).
3. Install battery access covers (see your -10).
4. Connect battery ground strap (WP 0337 00).
5. Start engine (see your -10).
6. Raise and lock ramp (see your -10).
7. Stop engine (see your -10).

END OF TASK

REPAIR BATTERY BOX (M577A3 AND M1068A3 ONLY)

0351 00

THIS WORK PACKAGE COVERS:

- Removal (page 0351 00-2).
- Clean and Inspect (page 0351 00-2).
- Installation (page 0351 00-2).

INITIAL SETUP:

Maintenance Level

Unit

References

See your -10

Tools and Special Tools

- General Mechanic's Tool Kit (WP 0926 00, Item 65)
- Hand Blind Riveter (WP 0926 00, Item 44)
- Socket Wrench Set (WP 0926 00, Item 72)
- Torque Wrench (WP 0926 00, Item 80)

Equipment Condition

- Engine stopped (see your -10)
- Carrier blocked (see your -10)
- Ramp lowered (see your -10)
- Battery access cover removed (see your -10)
- Battery ground lead disconnected (WP 0338 00)
- Battery leads removed (WP 0341 00)
- Battery and retainers removed (WP 0347 00)

Materials/Parts

- Bituminous coating compound (WP 0928 00, Item 13)
- Epoxy coating kit (WP 0928 00, Item 30)
- Sodium bicarbonate (WP 0928 00, Item 60)
- Lockwasher (4)

Personnel Required

Unit Mechanic

REMOVAL**NOTE**

Repair of the battery box is limited to replacement of the channels, frames, and latches.

1. Remove two screws (1), washers (2), and channel divider (3) from battery box frame (4).
2. Remove screws (5), lockwashers (6), washers (7), hardened washers (8), and battery box frame (4) from battery box. Discard lockwashers.
3. If damaged, remove rubber bumpers (9) from battery box. Discard bumpers.

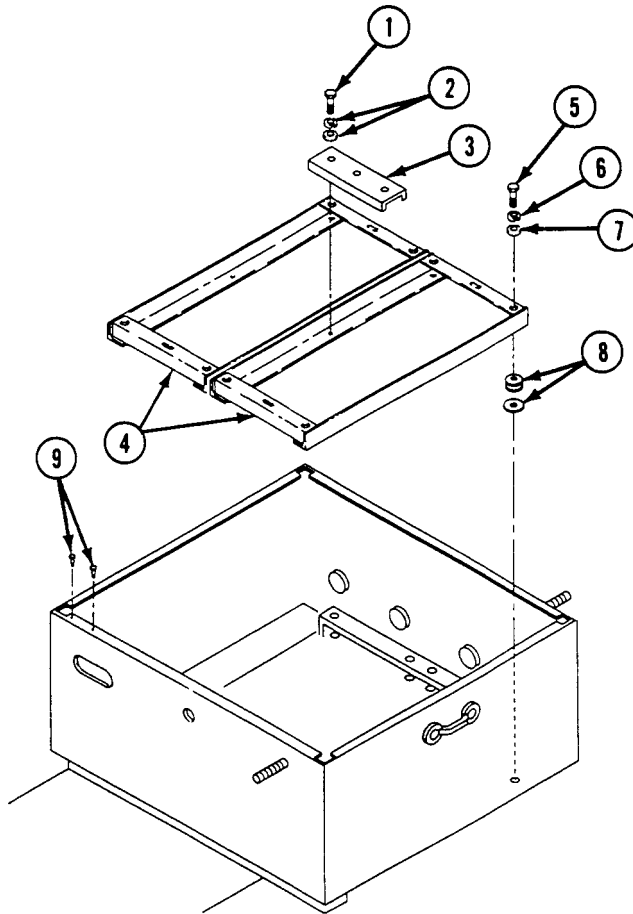
**■ CLEAN AND INSPECT**

1. Clean battery box by soaking in mixture of sodium bicarbonate and water. Dry parts and apply coating. Replace damaged, corroded, or missing parts.

INSTALLATION

1. If removed, install new rubber bumpers (1) on battery box.
2. Install battery box frame (2) in battery box. Secure with four hardened washers (3), washers (4), new lockwashers (5), and screws (6).

3. Install channel divider (7) on battery box frame (2). Secure with two washers (8) and screws (9). TIGHTEN SCREWS TO 96-120 LB-IN (11-14 N·m) TORQUE.

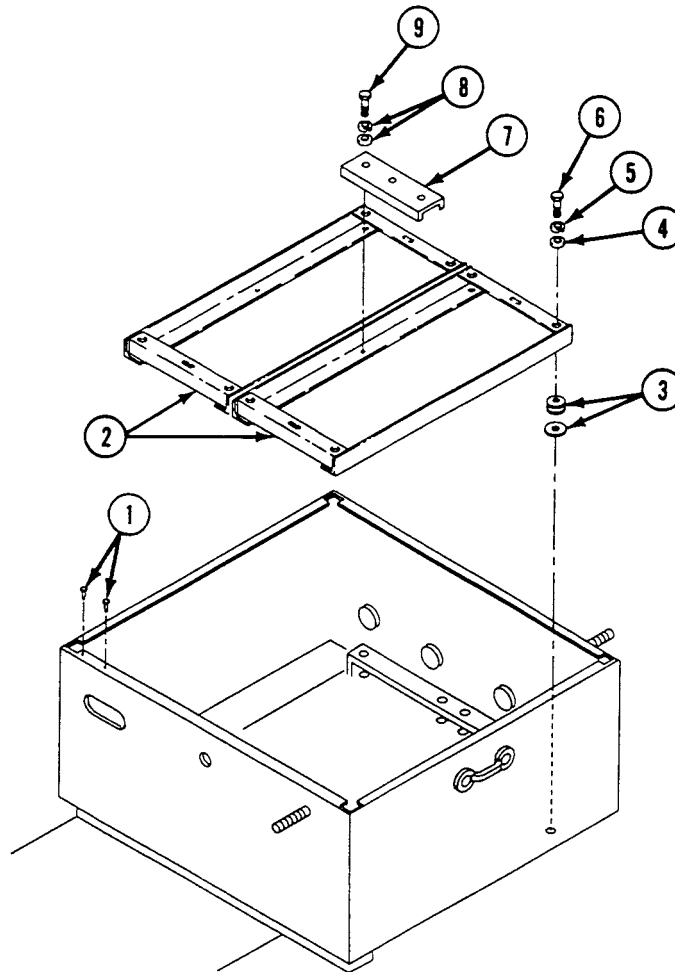

FOLLOW-THROUGH STEPS

1. Install batteries and retainers (WP 0347 00).
2. Install battery leads (WP 0341 00).
3. Connect battery ground lead (WP 0338 00).
4. Install battery access cover (see your -10).
5. Start engine (see your -10).
6. Raise and lock ramp (see your -10).
7. Stop engine (see your -10).

END OF TASK

REPAIR BATTERY BOX ACCESS COVER (M577A3 AND M1068A3 ONLY)

0352 00

THIS WORK PACKAGE COVERS:

Removal (page 0352 00-1).
 Installation (page 0352 00-2).

INITIAL SETUP:

Maintenance Level

Unit

References

See your -10

Tools and Special Tools

General Mechanic's Tool Kit (WP 0926 00, Item 65)

Equipment Condition

Engine stopped (see your -10)

Materials/Parts

Self-locking wing nut (2)

Carrier blocked (see your -10)

Personnel Required

Unit Mechanic

Ramp lowered (see your -10)

REMOVAL

1. Remove strap (1) from battery box (2) and raise right forward table (3).
2. Remove two self-locking wing nuts (4) and battery box access cover (5) from battery box (2). Discard self-locking wing nuts.
3. Remove two screws (6), washers (7), washers (8) and bumpers (9) from battery box access cover (5).

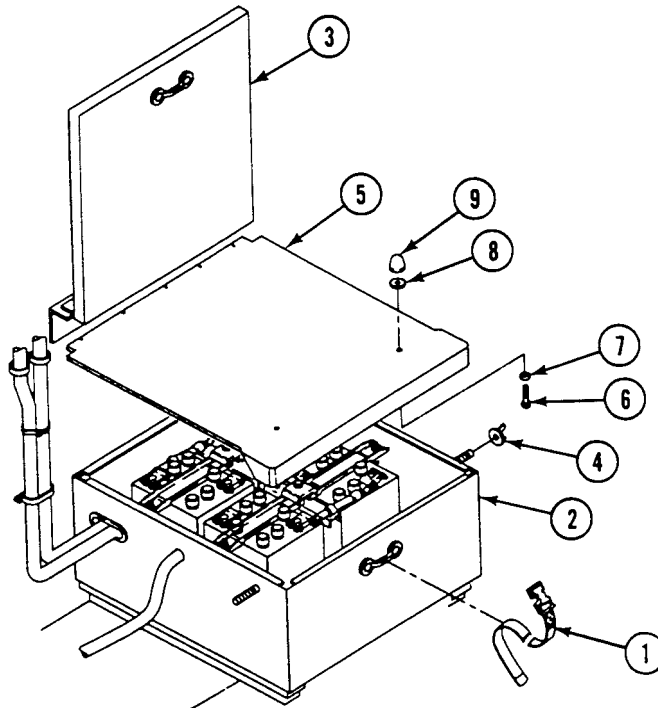

INSTALLATION

1. Install two bumpers (9), washers (8) (as required), washers (7), and screws (6) in battery box access cover (5).
2. Install battery box access cover (5) and two new self-locking wing nuts (4) on battery box (2).
3. Lower right forward table (3) on bumpers (9). Add washers (8) to raise bumpers or remove washers (8) to lower bumpers.
4. Install strap (1) on battery box (2).

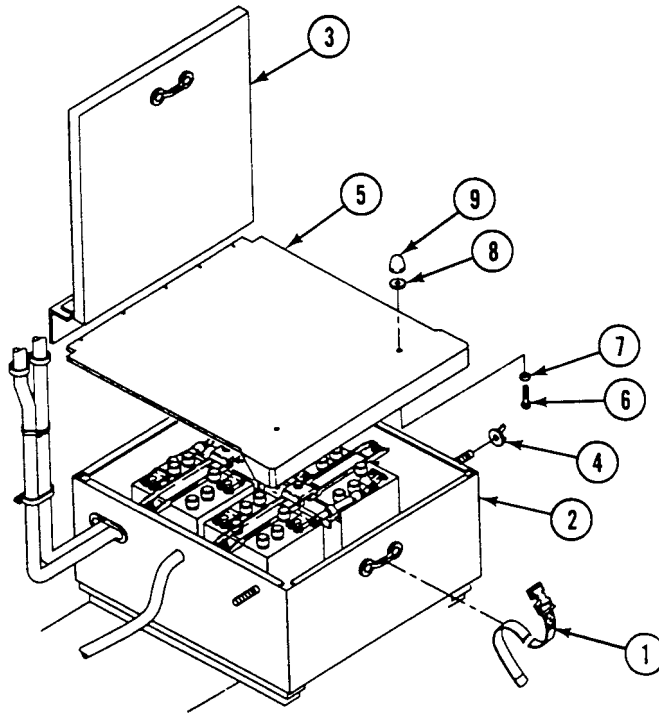
**FOLLOW-THROUGH STEPS**

1. Raise and lock ramp (see your -10).

END OF TASK

REPAIR BATTERY DRAWER (M1064A3 ONLY)

0353 00

THIS WORK PACKAGE COVERS:

- Removal (page 0353 00-1).
 - Cleaning and Inspection (page 0353 00-3).
 - Installation (page 0353 00-4).
-

INITIAL SETUP:

Maintenance Level

Unit

Personnel Required

Unit Mechanic

Tools and Special Tools

General Mechanic's Tool Kit (WP 0926 00, Item 65)

References

See your -10

Materials/Parts

- Grease (WP 0928 00, Item 12)
- Epoxy coating kit (WP 0928 00, Item 30)
- Sodium bicarbonate (WP 0928 00, Item 60)
- Locknut (18)
- Locknut (8)
- Locknut (4)
- Locknut (2)
- Locknut

Equipment Condition

- Engine stopped (see your -10)
 - Carrier blocked (see your -10)
 - Battery leads removed (WP 0343 00)
 - Batteries and retainers removed (WP 0349 00)
-

REMOVAL

1. Remove eight locknuts (1), washers (2), screws (3), and battery drawer (4) from two angles (5). Discard locknuts.
2. Extend two slide assemblies (6) to stops. Remove eight locknuts (7), washers (8), screws (9), and two angles (5) from slide assemblies. Discard locknuts.

3. Extend two slide assemblies (6) to stops. Remove 10 locknuts (10), washers (11), screws (12), and slide assemblies from hull mounts. Discard locknuts.

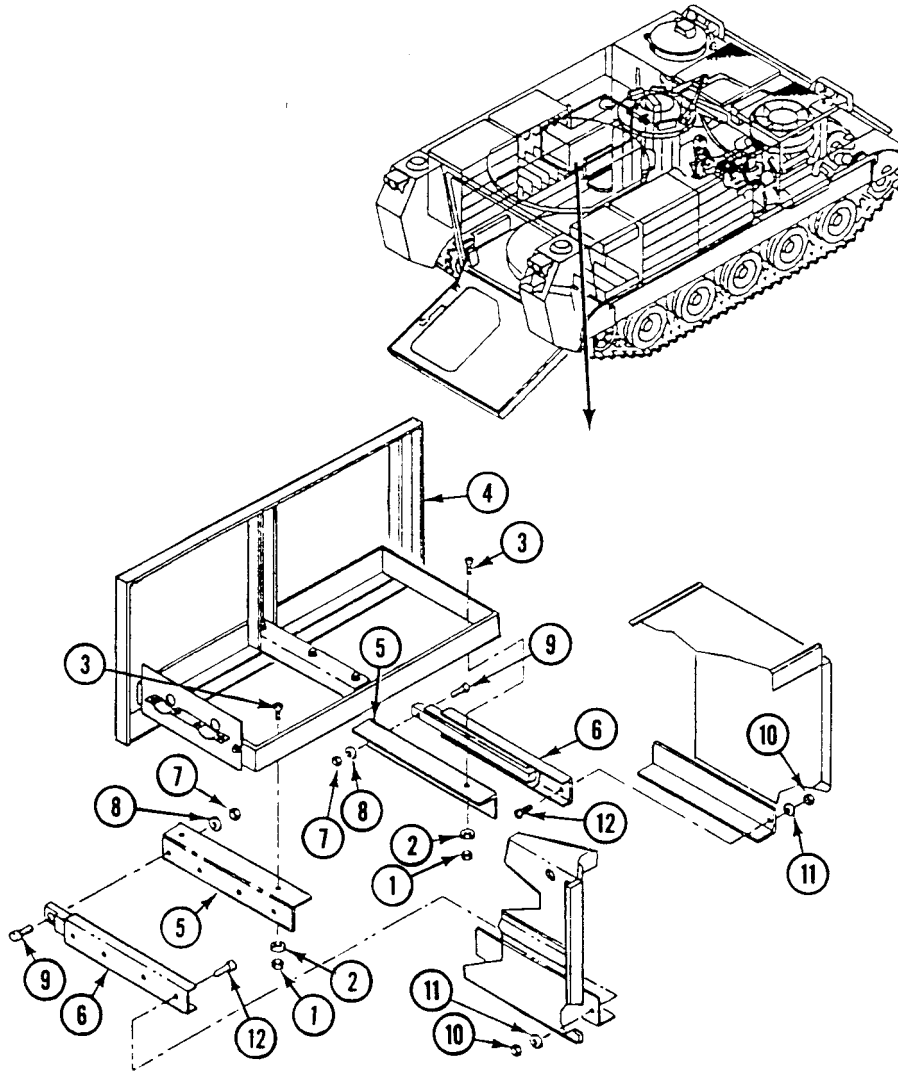

REPAIR BATTERY DRAWER (M1064A3 ONLY) — Continued**0353 00**

4. Remove three locknuts (1), washers (2), screws (3), and plate (4) from side of battery drawer (5). Discard locknuts.
5. Remove two locknuts (6), washers (7), screws (8), and channel divider (9) from battery drawer (5). Discard locknuts.
6. Remove locknut (10), cam (11), handle (12), and washer (13) from battery drawer (5). Remove key (14) from handle. Discard locknut.
7. If needed, remove locknut (15), screw (16), and wear plate (17) from hull mount.
8. If needed, remove two rubber bumpers (18) from front of battery drawer (5).

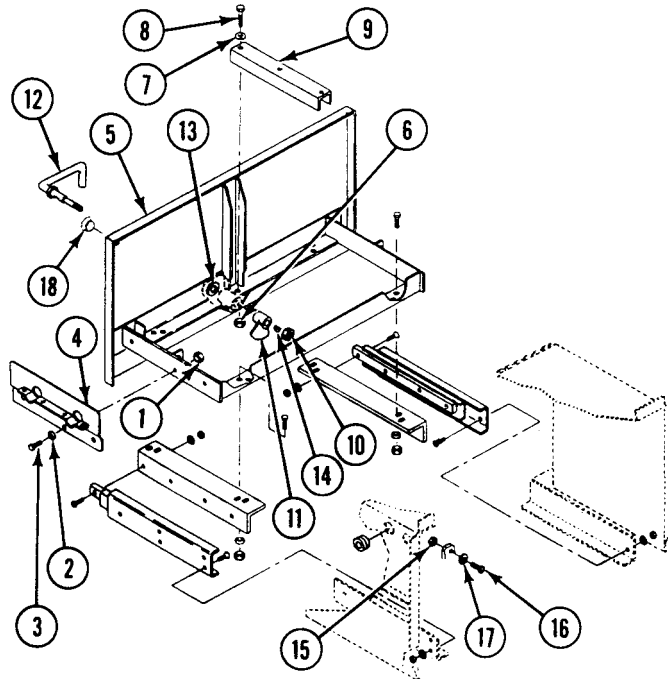
**CLEANING****CLEANING AND INSPECTION**

1. Inspect slide assemblies. If the slide binds or has damaged stops, install a new slide.
2. Clean drawer and parts by soaking in a solution of sodium bicarbonate and water. After foaming stops, flush with clean water and dry with clean cloth.
3. Inspect battery drawer for dents and cracks. If damaged beyond repair, install new drawer.

INSTALLATION

1. Apply epoxy coating to inside surface of battery drawer (5).
2. If removed, install rubber bumpers (18) in battery drawer (5).
3. If removed, place wear plate (17) on hull mount. Secure with screw (16) and new locknut (15).
4. Install washer (13) and handle (12) in battery drawer (5). Insert key (14) in handle and install cam (11). Secure with new locknut (10).
5. Place channel divider (9) in battery drawer (5). Secure with two screws (8), washers (7), and new locknuts (6).
6. Place plate (4) on side of drawer (5). Secure with three screws (3), washers (2), and new locknuts (1).

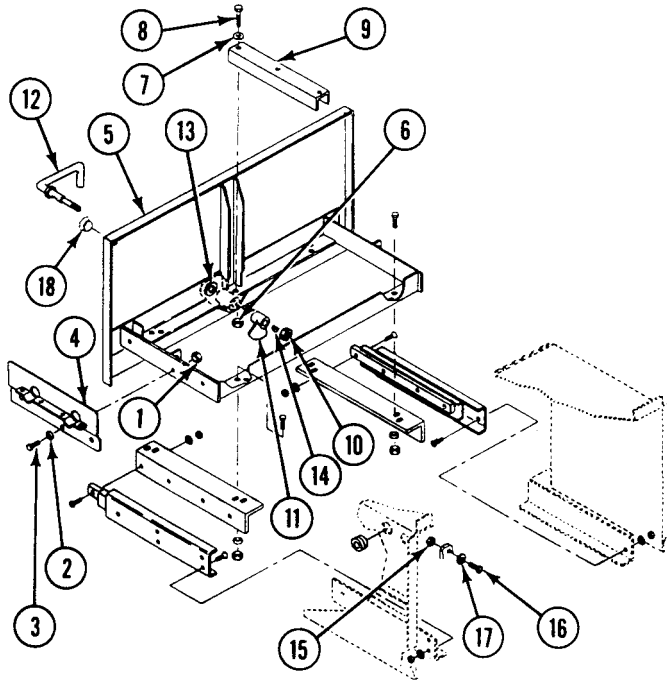

REPAIR BATTERY DRAWER (M1064A3 ONLY) — Continued

0353 00

7. Coat all bearing surfaces of two slide assemblies (1) with grease.
8. Place two slide assemblies (1) on hull mounts. Extend slide stops. Secure with 10 screws (2), washers (3), and new locknuts (4).
9. Extend two slide assemblies (1) to stops. Align two angles (5) with holes in slides. Secure with eight screws (6), washers (7), and new locknuts (8).
10. Align battery drawer (9) with holes in two angles (5). Secure with eight screws (10), washers (11), and new locknuts (12).

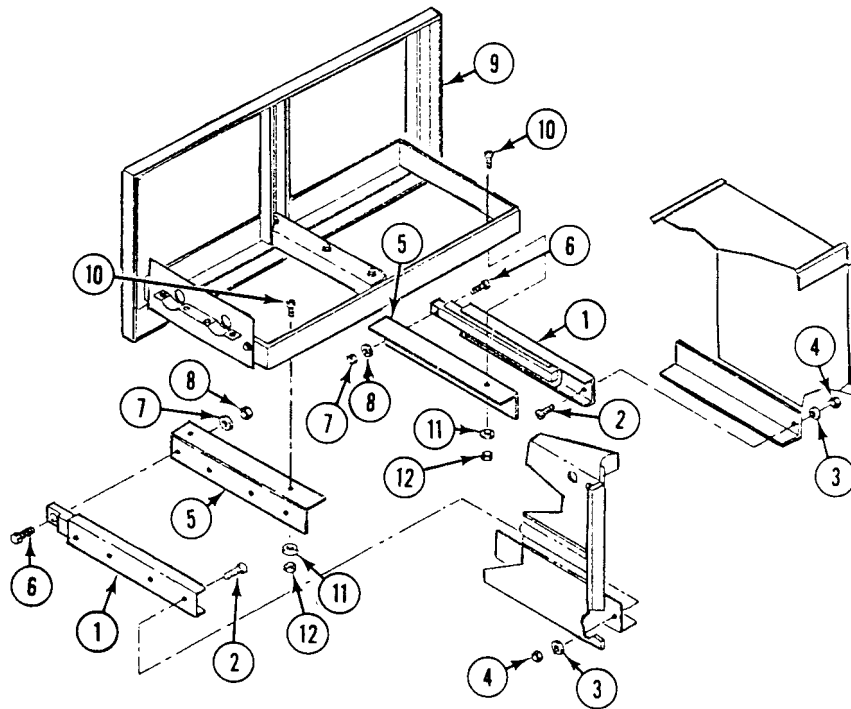

FOLLOW-THROUGH STEPS

1. Install batteries and retainers (WP 0349 00).
2. Install battery leads (WP 0343 00).
3. Start engine (see your -10).
4. Raise and lock ramp (see your -10).
5. Stop engine (see your -10).

END OF TASK

REPAIR BATTERY BOX (RIGHT SIDE) (M1064A3)

0354 00

THIS WORK PACKAGE COVERS:

- Removal (page 0354 00-1).
 - Cleaning and Inspection (page 0354 00-2).
 - Installation (page 0354 00-3).
-

INITIAL SETUP:

Maintenance Level

Unit

Personnel Required

Unit Mechanic 63T10

Tools and Special Tools

- General Mechanic's Tool Kit (WP 0926 00, Item 65)
- Torque Wrench (WP 0926 00, Item 83)

References

See your -10

Materials/Parts

- Bituminous coating compound (WP 0928 00, Item 13)
- Epoxy coating kit (WP 0928 00, Item 30)
- Sodium bicarbonate (WP 0928 00, Item 60)
- Locknut (4)
- Lockwasher (4)
- Mount (4)

Equipment Condition

- Engine stopped (see your -10)
 - Carrier blocked (see your -10)
 - Ramp lowered (see your -10)
 - Battery box cover/seat removed (see your -10)
 - Battery leads removed (WP 0344 00)
 - Batteries and retainers removed (WP 0349 00)
-

REMOVAL

1. Remove four screws (1), eight washers (2), and battery box frame (3) with four frame mounts (4) from battery box brackets (5).

REPAIR BATTERY BOX (RIGHT SIDE) (M1064A3) — Continued**0354 00**

2. Remove four frame mounts (4) from battery box frame (3). Discard mounts.
3. Remove four screws (6), lockwashers (7), and battery box (8) from carrier. Discard lockwashers.
4. Remove four locknuts (9), washers (10), screws (11), and two latches (12) from battery box (8). Discard locknuts.
5. Remove two screws (13), washers (14), and channel divider (15) from battery box frame (3).

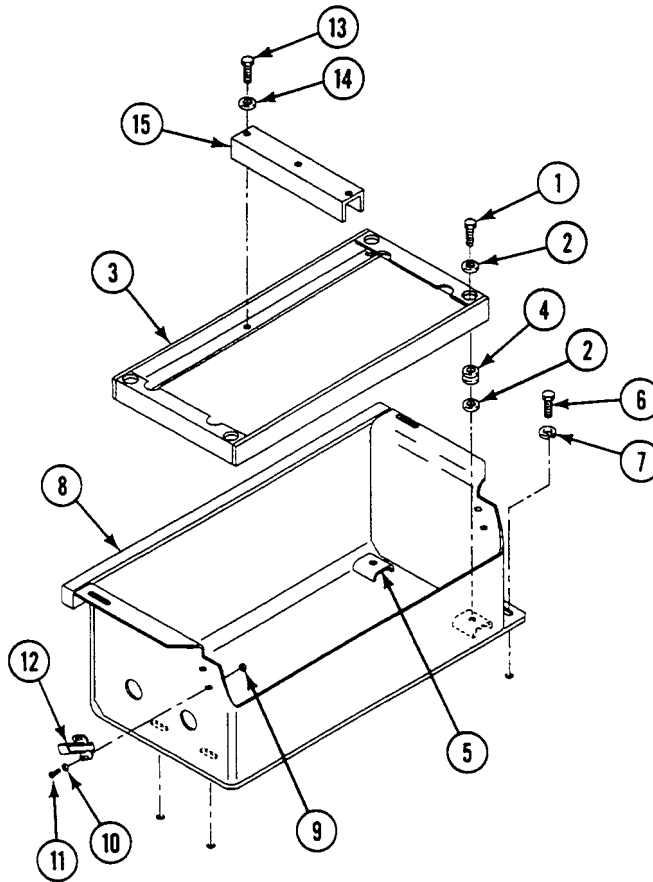
**CLEANING****CLEANING AND INSPECTION**

1. Clean battery box by soaking in mixture of sodium bicarbonate and water. Dry parts and apply coating. Replace damaged, corroded, or missing parts.

INSTALLATION

1. Install channel divider (1) on battery box frame (2). Secure with two screws (3) and washers (4). **TIGHTEN SCREWS TO 120-192 LB-IN (14-22 N·m) TORQUE.**
2. Place two latches (5) on side of battery box (6). Secure with four screws (7), washers (8), and new locknuts (9).
3. Install battery box (6) in carrier. Secure with four screws (10) and new lockwashers (11).
4. Install four new frame mounts (12) in battery box frame (2).
5. Position battery box frame (2) on battery box brackets (13). Secure with four screws (14) and eight washers (15). **TIGHTEN SCREWS TO 96-120 LB-IN (11-14 N·m.) TORQUE.**

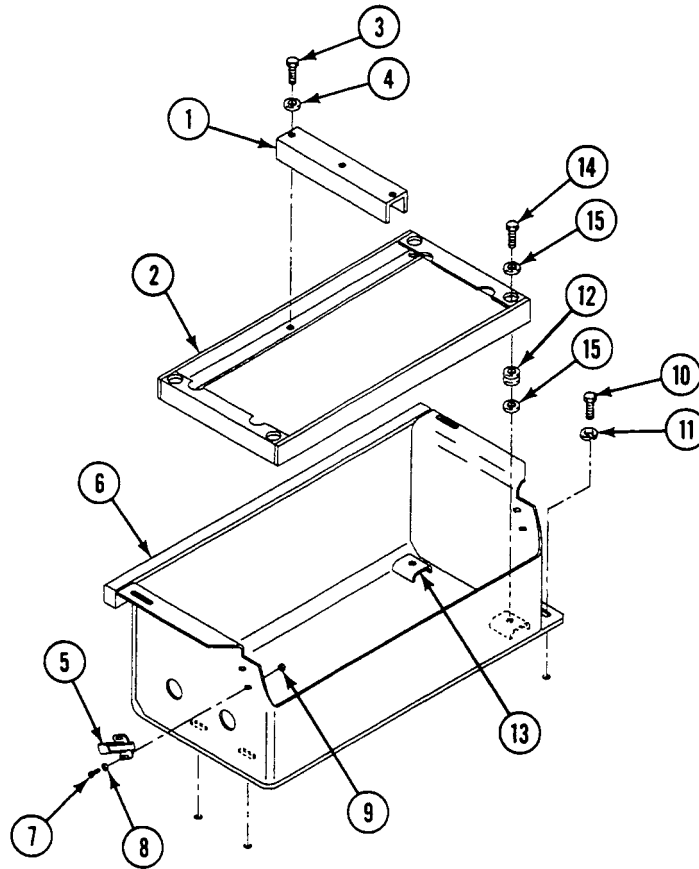

FOLLOW-THROUGH STEPS

1. Install batteries and retainers (WP 0349 00).
2. Install battery leads (WP 0344 00).
3. Install battery box cover/seat (see your -10).
4. Start engine (see your -10).
5. Raise and lock ramp (see your -10).
6. Stop engine (see your -10).

END OF TASK

REPLACE BATTERY BOX VENT FITTING (M58 ONLY)

0355 00 ■

THIS WORK PACKAGE COVERS:

Removal (page 0355 00-1).
 Installation (page 0355 00-3).

INITIAL SETUP:

Maintenance Level

Unit

Personnel Required

Unit Mechanic

Tools and Special Tools

General Mechanic's Tool Kit (WP 0926 00, Item 65)

References

See your -10

Materials/Parts

Sealing compound (WP 0928 00, Item 49)
 Lockwasher (6)

Equipment Condition

Engine stopped (see your -10)
 Carrier blocked (see your -10)
 Ramp lowered (see your -10)

REMOVAL

WARNING



Gas from batteries can explode and injure you. Do not allow sparks near batteries. Battery acid can blind or burn you. Do not get acid on your skin or into your eyes.

REPLACE BATTERY BOX VENT FITTING (M58 ONLY) — Continued

0355 00

1. Remove six screws (1), lockwashers (2), and washers (3) securing battery box vent fitting (4) to vehicle hull (5). Discard lockwashers.
2. Remove hose clamp (6) and hose (7) from battery box (8).
3. Remove battery box vent fitting (4) and attached hose (7) from vehicle hull (5).
4. Remove hose clamp (9) and hose (7) from battery box vent fitting (4).

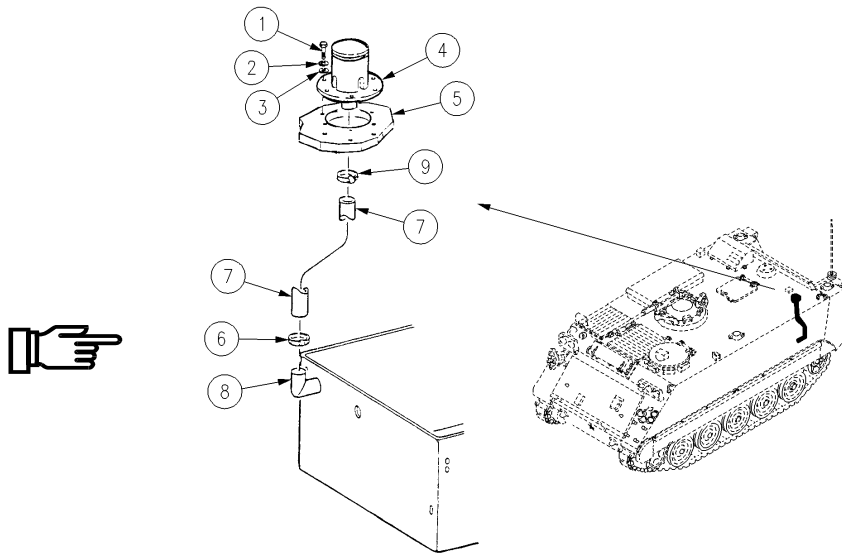

INSTALLATION

1. Install hose (1) on battery box (2) with hose clamp (3).
2. Apply a bead of sealing compound around hole (4) in vehicle hull (5).
3. Align holes in battery box vent fitting (6) with holes in vehicle hull (5).
4. Secure battery box vent fitting (6) on vehicle hull (5) using six new lockwashers (7), washers (8), and screws (9).
5. Install hose (1) on battery box vent fitting (6) with hose clamp (10).

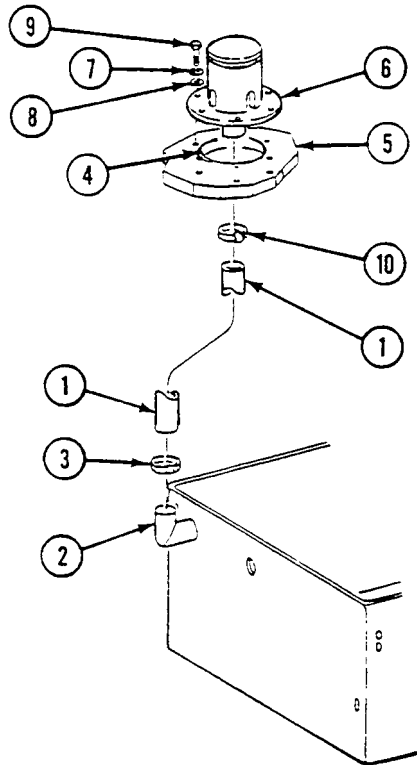
**FOLLOW-THROUGH STEPS**

1. Start engine (see your -10).
2. Raise and lock ramp (see your -10).
3. Stop engine (see your -10).

END OF TASK

REPLACE BATTERY TO MASTER SWITCH LEAD (CIRCUIT 6) (M113A3 AND M1059A3 ONLY)

0356 00

THIS WORK PACKAGE COVERS:

Removal (page 0356 00-1).
 Installation (page 0356 00-4).

INITIAL SETUP:

Maintenance Level

Unit

References

See your -10

Tools and Special Tools

General Mechanic's Tool Kit (WP 0926 00, Item 65)

Equipment Condition

Engine stopped (see your -10)
 Carrier blocked (see your -10)
 Ramp lowered (see your -10)
 Spall liners opened (see your -10)
 Battery ground strap disconnected (WP 0337 00)
 Battery access covers removed (see your -10)

Materials/Parts

Grommet
 Locknut (8)
 Lockwasher (2)

Personnel Required

Unit Mechanic

REMOVAL

WARNING



Gas from batteries can explode and injure you. Do not allow sparks near batteries. Battery acid can blind or burn you. Do not get acid on your skin or eyes.

WARNING



Electrical current can burn you. Disconnect battery ground lead before you start task.

REPLACE BATTERY TO MASTER SWITCH LEAD (CIRCUIT 6) (M113A3 AND M1059A3 ONLY) — Continued

0356 00

1. Remove nut (1), screw (2), circuit 6 lead (3), and positive jumper lead (4) from positive terminal (5) of front battery (6).

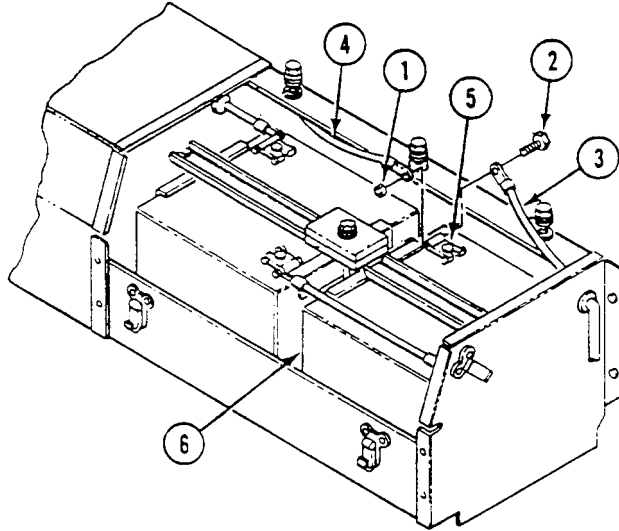

REPLACE BATTERY TO MASTER SWITCH LEAD (CIRCUIT 6) (M113A3 AND M1059A3 ONLY) — Continued

0356 00 ■

2. Remove circuit 6 lead (1) and grommet (2) from front battery box (3). Discard grommet.
3. Remove two clamps (4), screws (5), lockwashers (6), and circuit 6 lead (1) from hull. Discard lockwashers.
4. Remove eight locknuts (7), screws (8), washers (9), and master switch panel (10) from distribution box (11). Discard locknuts.
5. Remove nut (12), screw (13), and circuit 6 lead (1) from conductor bus (14) in master switch panel (10).
6. Remove circuit 6 lead (1) and grommet (15) from master switch panel (10). Discard grommet. Remove lead from carrier.

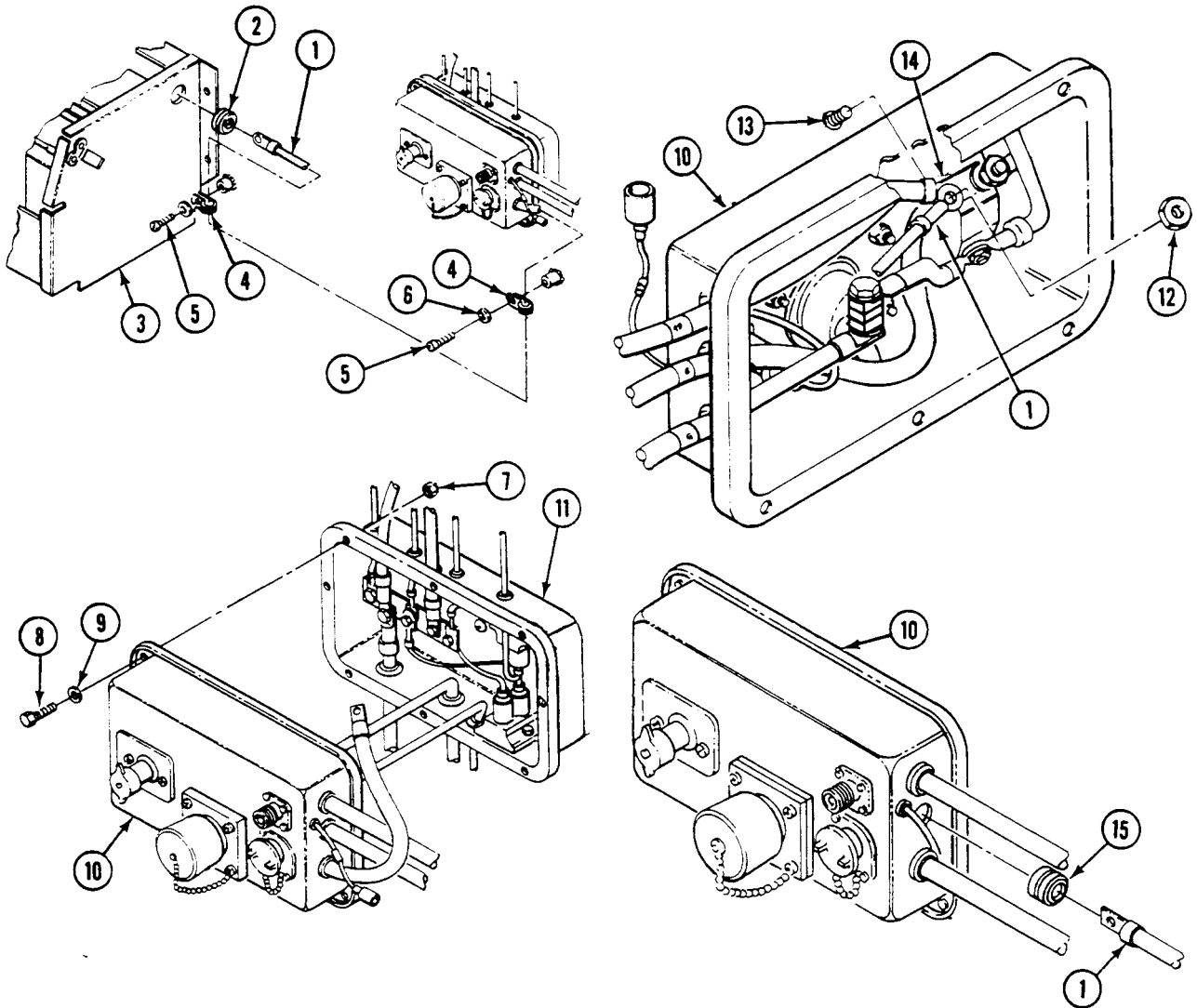

■ REPLACE BATTERY TO MASTER SWITCH LEAD (CIRCUIT 6) (M113A3 AND M1059A3 ONLY) — Continued

0356 00

INSTALLATION

1. Install new grommet (15) on circuit 6 lead (1). Install lead and grommet in master switch panel (10).

NOTE

Make sure circuit 6 lead, circuit 2, and circuit 400 lead are installed before tightening nut.

2. Install circuit 6 lead (1) on conductor bus (14) in master switch panel (10). Secure with screw (13) and nut (12).
3. Install master switch panel (10) on distribution box (11). Secure with eight screws (8), washers (9), and new locknuts (7).

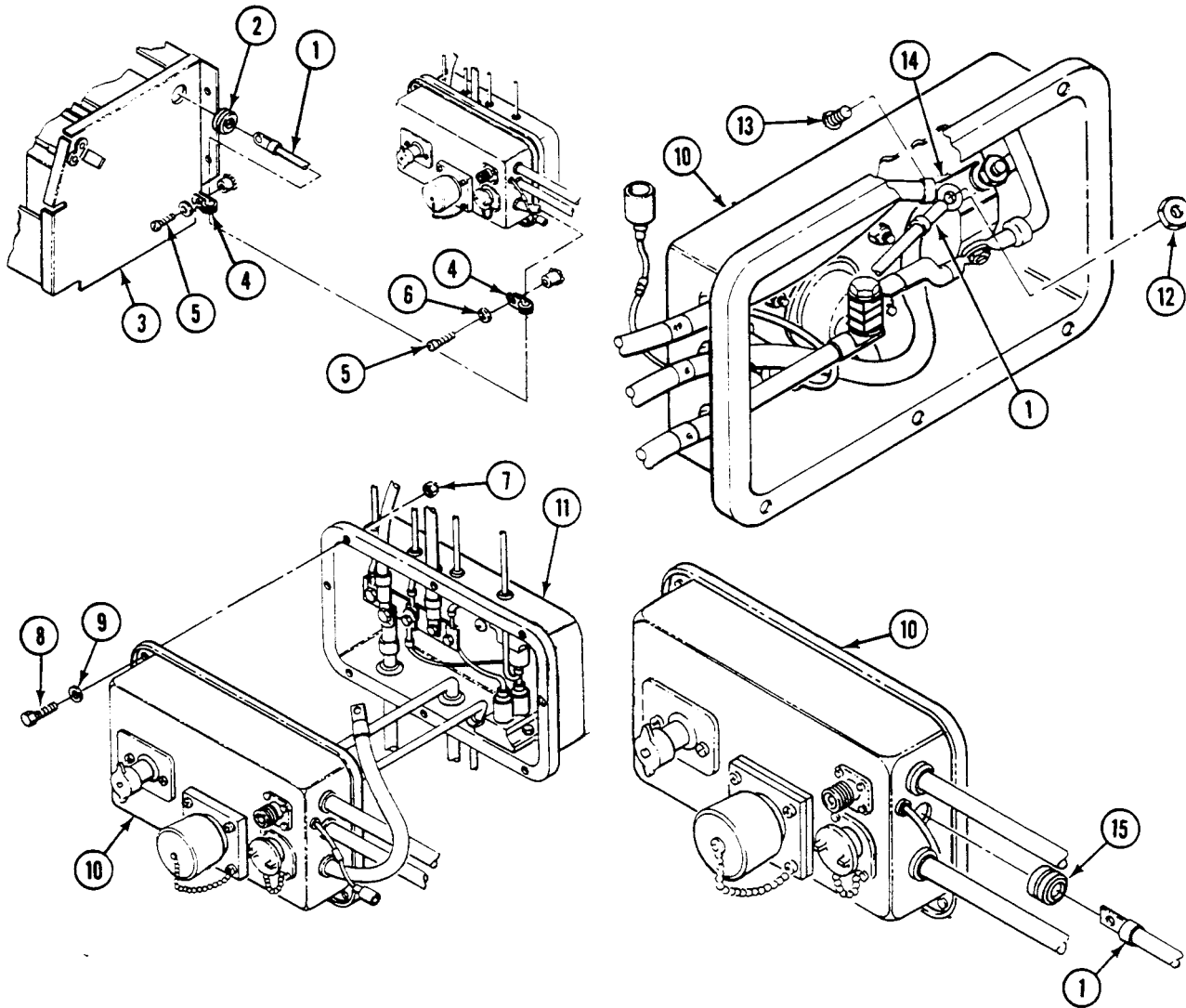

REPLACE BATTERY TO MASTER SWITCH LEAD (CIRCUIT 6) (M113A3 AND M1059A3 ONLY) — Continued

0356 00 ■

4. Route circuit 6 lead (1) through hull support channel (2).
5. Install two clamps (3) on circuit 6 lead (1). Secure with two screws (4) and new lockwashers (5).
6. Install new grommet (6) on circuit 6 lead (1). Route lead through side of front battery box (7).
7. Install circuit 6 lead (1) and positive jumper lead (8) on positive terminal (9) of front battery. Secure with screw (10) and nut (11).

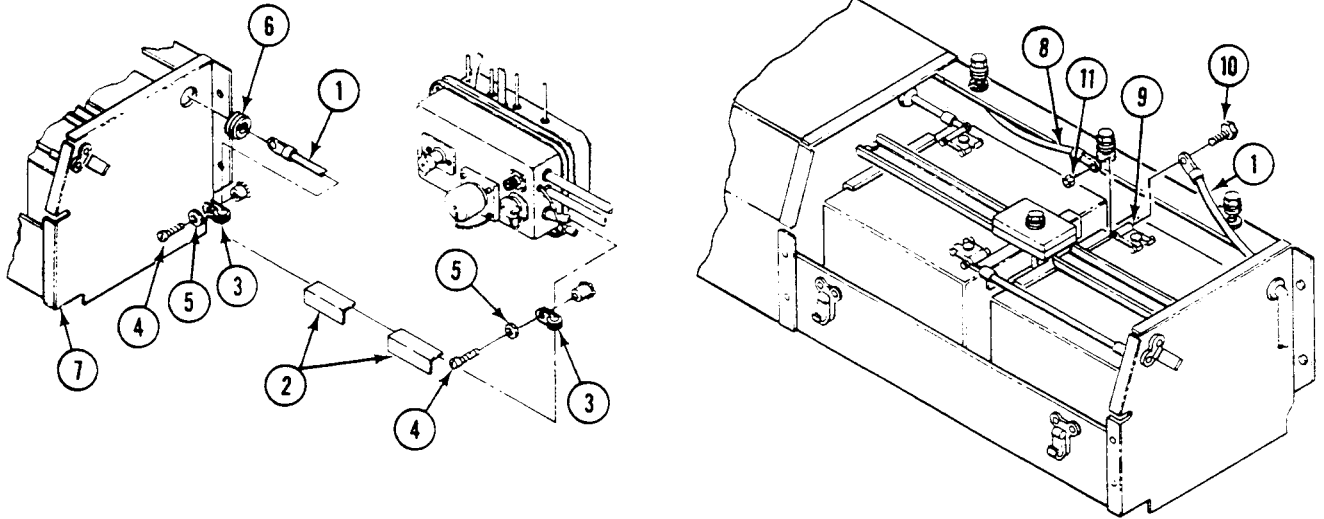

FOLLOW-THROUGH STEPS

1. Install battery access covers (see your -10).
2. Connect battery ground strap (WP 0337 00).
3. Close spall liners (see your -10).
4. Start engine (see your -10).
5. Raise and lock ramp (see your -10).
6. Stop engine (see your -10).

END OF TASK

REPLACE BATTERY TO MASTER SWITCH LEAD (CIRCUIT 6) (M577A3 AND M1068A3 ONLY)

0357 00

THIS WORK PACKAGE COVERS:

Removal (page 0357 00-1).
 Installation (page 0357 00-4).

INITIAL SETUP:

Maintenance Level

Unit

References

See your -10

Tools and Special Tools

General Mechanic's Tool Kit (WP 0926 00, Item 65)

Equipment Condition

Engine stopped (see your -10)
 Carrier blocked (see your -10)
 Ramp lowered (see your -10)
 Battery ground lead disconnected (WP 0338 00)
 Battery access cover removed (see your -10)

Materials/Parts

Locknut (8)
 Lockwasher (5)

Personnel Required

Unit Mechanic

REMOVAL

WARNING



Gas from batteries can explode and injure you. Do not allow sparks near batteries. Battery acid can blind or burn you. Do not get acid on your skin or in your eyes.

WARNING



Electrical current can burn you. Disconnect battery ground lead before you start task.

1. Remove nut (1), screw (2), washer (3), and all leads (4) from terminal (5).

REPLACE BATTERY TO MASTER SWITCH LEAD (CIRCUIT 6) (M577A3 AND M1068A3 ONLY) — Continued

0357 00

2. Remove circuit 6 lead (6) from battery box (7).
3. Remove as many straps (8) as necessary to free circuit 6 lead (6) from other harnesses.
4. Remove three screws (9), lockwashers (10), and five clamps (11) from weldnuts. Discard lockwashers.
5. Remove three clamps (11) from circuit 6 lead (6).

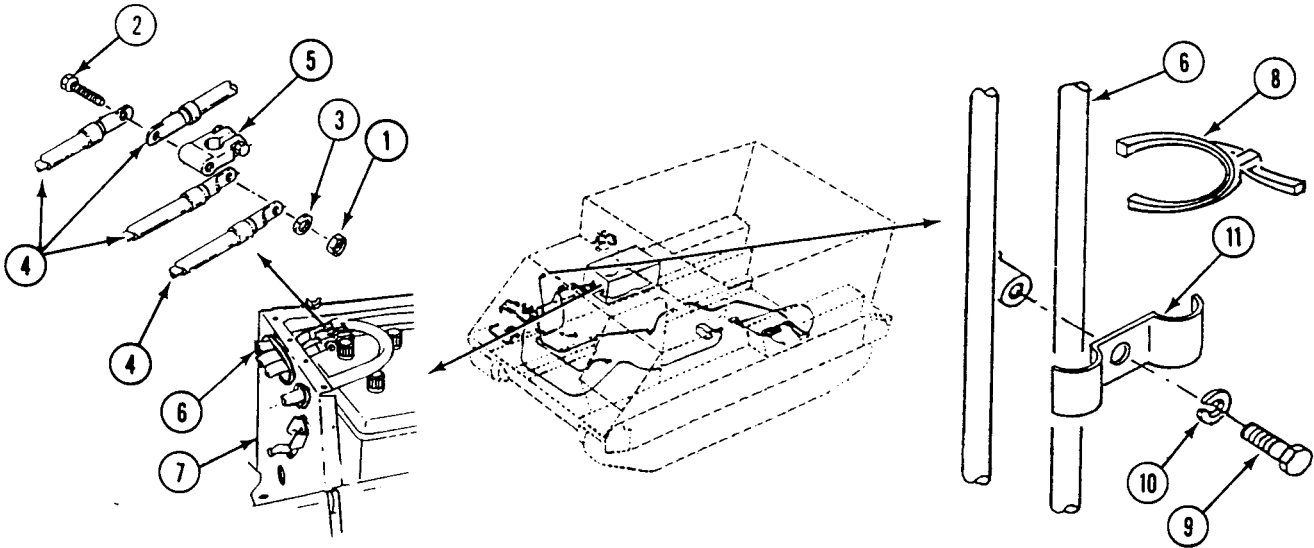

6. Tie cord to circuit 6 lead (1) with strong knot. Pull circuit 6 lead (1) through hull transverse beam (2) from opposite side of carrier. Untie cord from circuit 6 lead (1), leaving cord hanging from both ends of hull transverse beam (2).
7. Remove two screws (3), lockwashers (4), clamps (5), and circuit 6 lead (1) from weldnuts. Discard lockwashers.

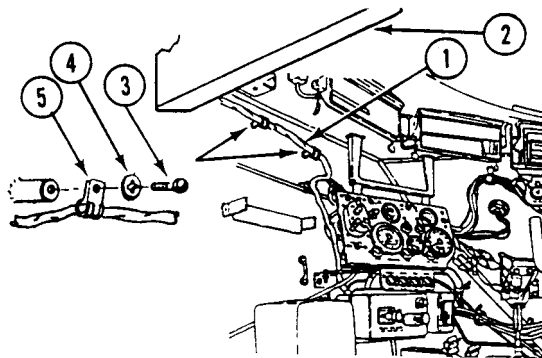

REPLACE BATTERY TO MASTER SWITCH LEAD (CIRCUIT 6) (M577A3 AND M1068A3 ONLY) — Continued

0357 00

8. Remove eight locknuts (6), screws (7), washers (8), and master switch panel (9) from distribution box (10). Discard locknuts.

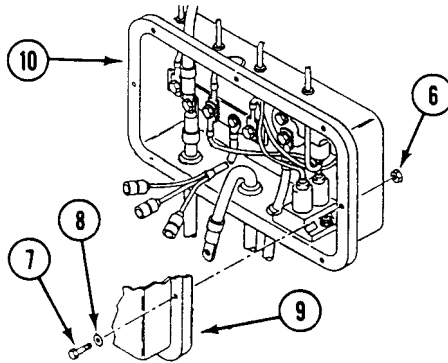

9. Remove nut (11), screw (12), and circuit 6 lead (1) from conductor bus (13) in master switch panel (9).
10. Remove circuit 6 lead (1) and grommet (14) from master switch panel (9). Remove circuit 6 (1) lead from carrier.

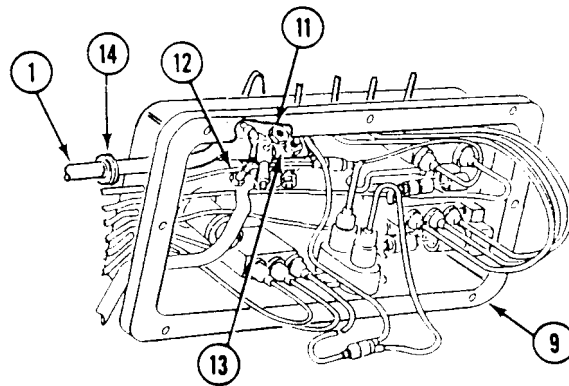

REPLACE BATTERY TO MASTER SWITCH LEAD (CIRCUIT 6) (M577A3 AND M1068A3 ONLY) — Continued

0357 00

INSTALLATION

1. Install grommet (14) on circuit 6 lead (1). Install lead and grommet in master switch panel (9).

NOTE

Make sure circuit 6 lead, circuit 2 lead, and circuit 400 lead are installed before tightening nut.

2. Install circuit 6 lead (1) on conductor bus (13) in master switch panel (9). Secure with screw (12) and nut (11).

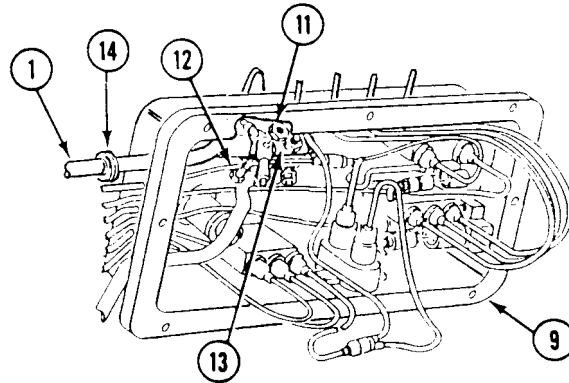

3. Install master switch panel (9) on distribution box (10). Secure with eight screws (7), washers (8), and new locknuts (6).

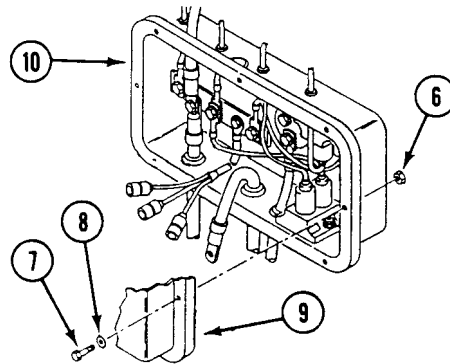

REPLACE BATTERY TO MASTER SWITCH LEAD (CIRCUIT 6) (M577A3 AND M1068A3 ONLY) — Continued

0357 00

4. Tie cord hanging from hull transverse beam (1) to new or repaired circuit 6 lead (2) with strong knot. Pull cord from opposite side of carrier, pulling circuit 6 lead (2) through hull transverse beam (1). Untie cord from circuit 6 lead (2).
5. Install two clamps (3) on circuit 6 lead (2) and secure to hull weldnut with two screws (4) and new lockwashers (5).

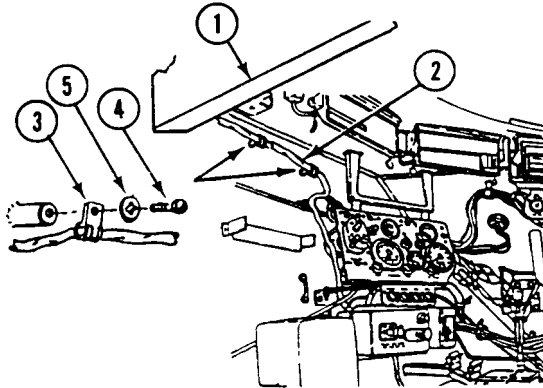

6. Install three clamps (6) on circuit 6 lead (2).
7. Install five clamps (6) on weldnuts with three screws (7) and new lockwashers (8).
8. Secure other harnesses to circuit 6 lead (2) with new straps (9).

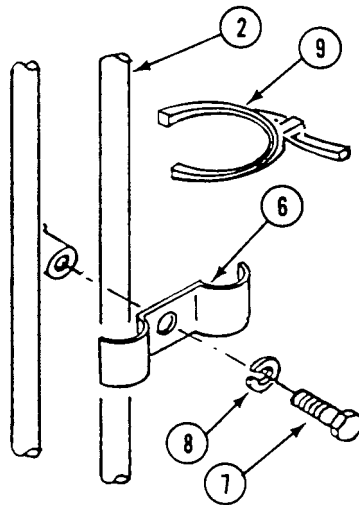

REPLACE BATTERY TO MASTER SWITCH LEAD (CIRCUIT 6) (M577A3 AND M1068A3 ONLY) — Continued

0357 00

9. Install circuit 6 lead (2) in battery box (10).
10. Install screw (11), washer (12), all leads (13), and nut (14) on battery terminal (15).

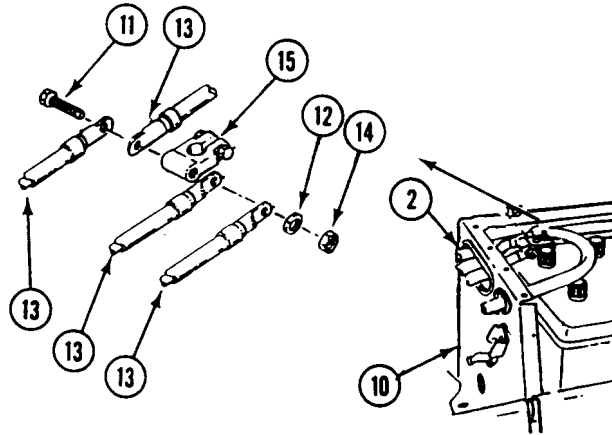
**FOLLOW-THROUGH STEPS**

1. Connect battery ground lead (WP 0338 00).
2. Install battery access cover (see your -10).
3. Turn MASTER SWITCH ON to check that circuit 6 lead is installed right. MASTER SWITCH ON light should come on (see your -10).
4. Start engine (see your -10).
5. Raise and lock ramp (see your -10).
6. Stop engine (see your -10).

END OF TASK

REPLACE BATTERY TO MASTER SWITCH LEAD (CIRCUIT 6) (M1064A3 ONLY)

0358 00

THIS WORK PACKAGE COVERS:

Removal (page 0358 00-1).
 Installation (page 0358 00-5).

INITIAL SETUP:

Maintenance Level

Unit

References

See your -10

Tools and Special Tools

General Mechanic's Tool Kit (WP 0926 00, Item 65)

Equipment Condition

Engine stopped (see your -10)
 Carrier blocked (see your -10)
 Ramp lowered (see your -10)
 Battery ground strap disconnected (WP 0337 00)
 Battery drawer opened (see your -10)

Materials/Parts

Grommet
 Locknut (8)
 Lockwasher (2)

Personnel Required

Unit Mechanic

REMOVAL

WARNING



Gas from batteries can explode and injure you. Do not allow sparks near batteries. Battery acid can blind or burn you. Do not get acid on your skin or eyes.

1. Remove nut (1), screw (2), circuit 772 lead (3), circuit 778 lead (4), circuit 6 lead (5), circuit 48 lead (6), and circuit 6P lead (7) from terminal lug (8).

REPLACE BATTERY TO MASTER SWITCH LEAD (CIRCUIT 6) (M1064A3 ONLY) —
Continued

0358 00

2. Remove circuit 6 lead (5) and grommet (9) from battery compartment. Discard grommet.

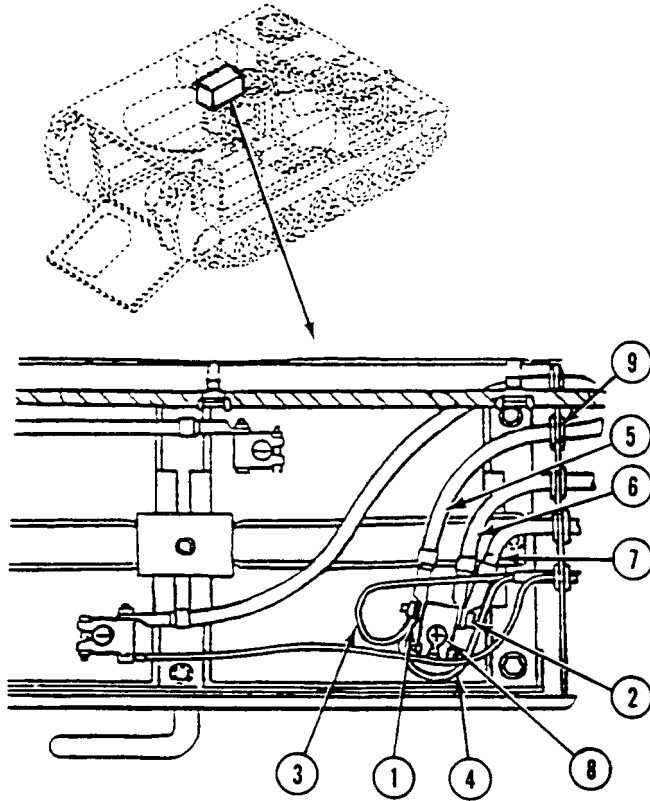

REPLACE BATTERY TO MASTER SWITCH LEAD (CIRCUIT 6) (M1064A3 ONLY) —
Continued

0358 00

3. Remove screw (1), lockwasher (15), clamp (3) and circuit 6 lead (2) from weldnut. Discard lockwasher.
4. Remove two screws (4), lockwashers (5), and clamps (6) from two hull weldnuts. Remove circuit 6 lead (2) from clamps (6). Discard lockwashers.

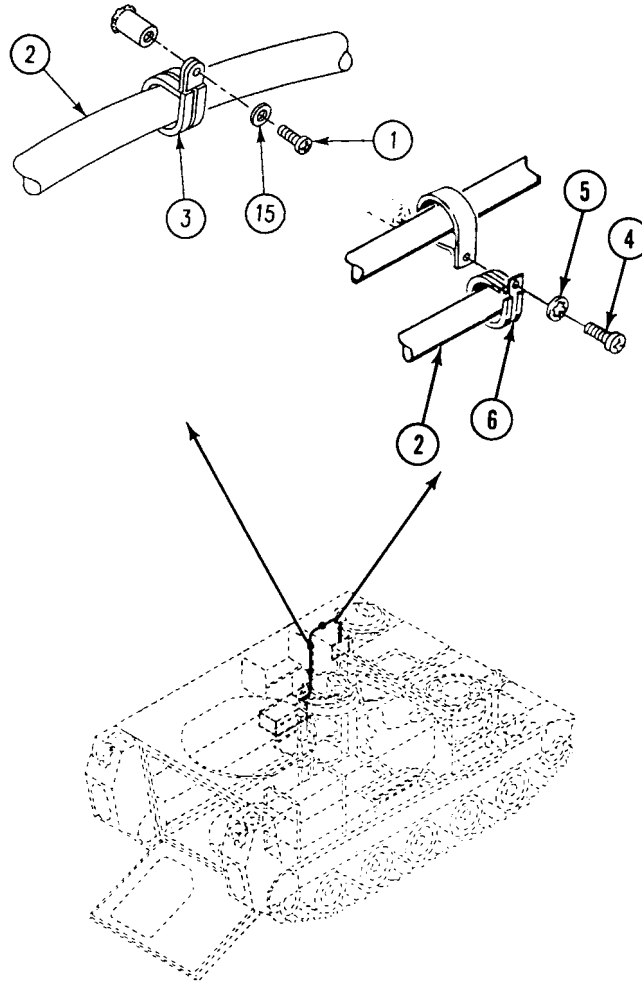

REPLACE BATTERY TO MASTER SWITCH LEAD (CIRCUIT 6) (M1064A3 ONLY) —
Continued

0358 00

5. Remove eight locknuts (7), screws (8), washers (9), and master switch panel (10) from distribution box (11). Discard locknuts.

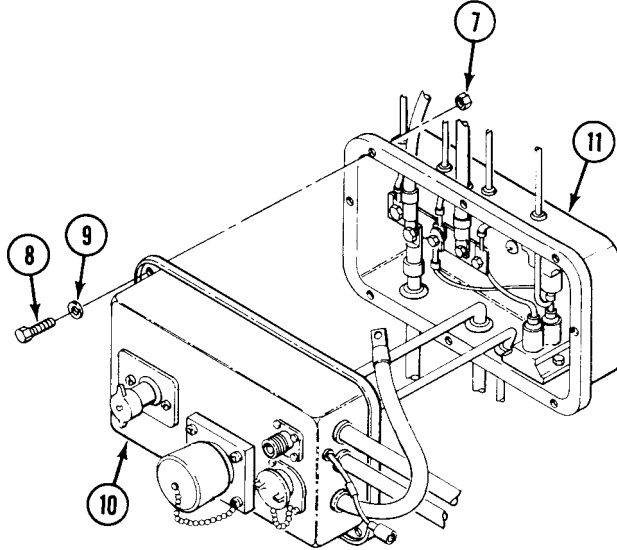

6. Remove nut (12), screw (13), and circuit 6 lead (2) from conductor bus (14) in master switch panel (10).

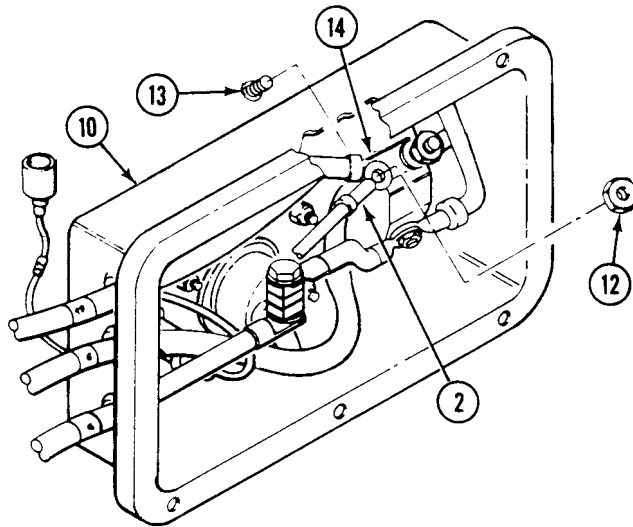

**REPLACE BATTERY TO MASTER SWITCH LEAD (CIRCUIT 6) (M1064A3 ONLY) —
Continued**

0358 00

7. Route circuit 6 lead (1) and grommet (2) out of master switch panel (3). Discard grommet. Remove lead from carrier.

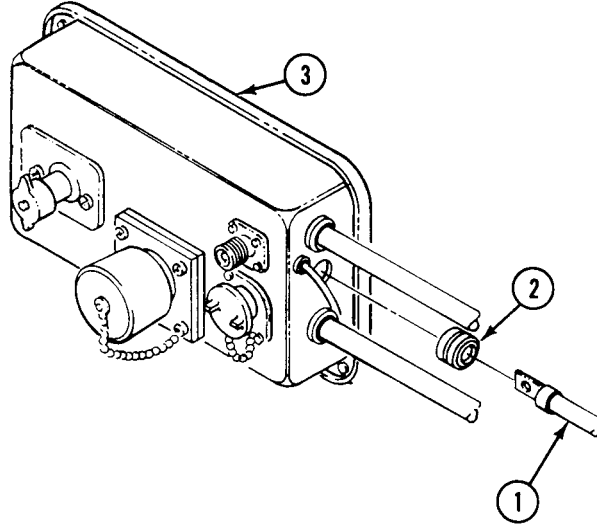

INSTALLATION

1. Install new grommet (2) on circuit 6 lead (1). Install lead and grommet in master switch panel (3).

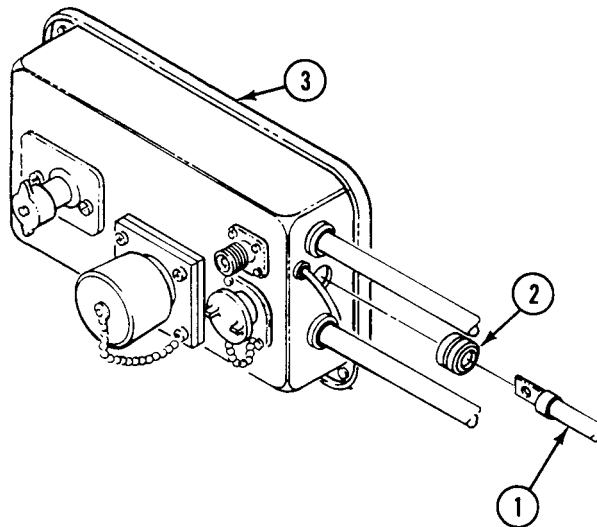

NOTE

Make sure circuit 6, circuit 2, and circuit 400 leads are installed before tightening nut.

2. Install circuit 6 lead (1) on conductor bus (4) in master switch panel (3). Secure with screw (5) and nut (6).

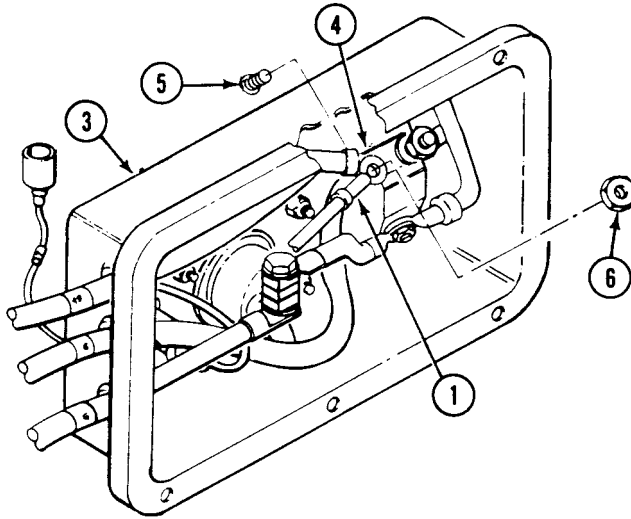

3. Install master switch panel (3) on distribution box (7). Secure with eight screws (8) washers (9), and new locknuts (10).

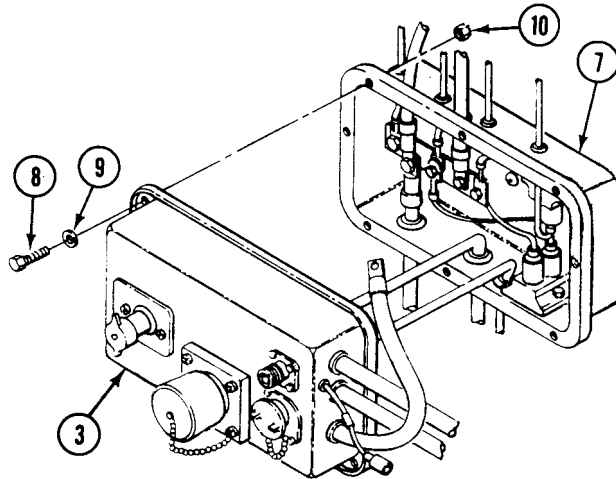

**REPLACE BATTERY TO MASTER SWITCH LEAD (CIRCUIT 6) (M1064A3 ONLY) —
Continued**

0358 00

4. Route circuit 6 lead (1) below two clamps (2) on upper left wall.
5. Install two clamps (3) on circuit 6 lead (1). Secure, along with clamps (2), to two hull weldnuts with two screws (4) and new lockwashers (5).
6. Install clamp (3) with circuit 6 lead (2) on weldnut with screw (1) and new lockwasher (15).

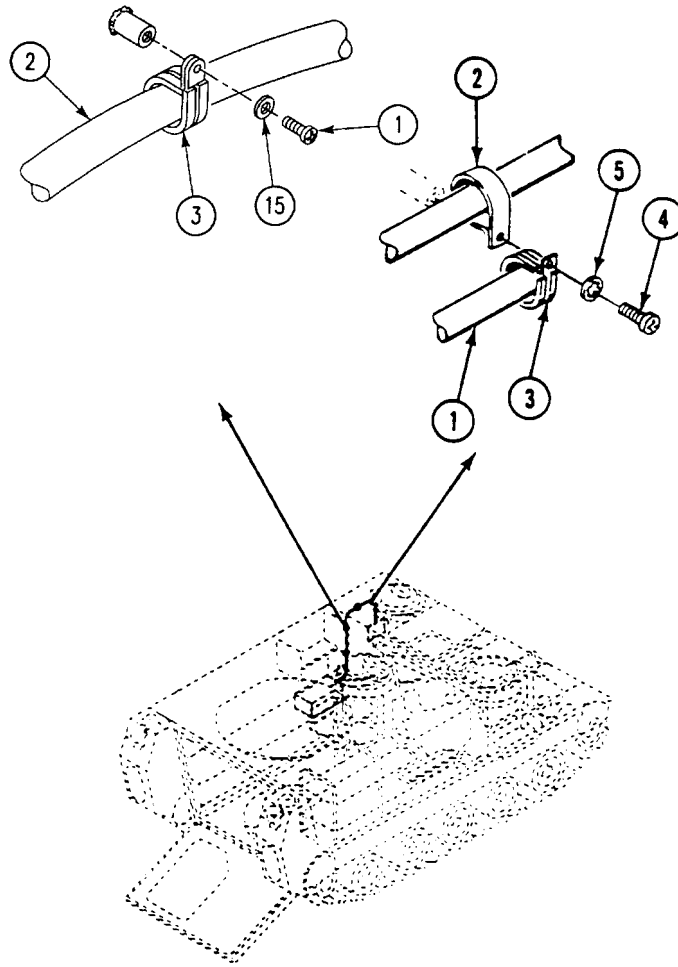

REPLACE BATTERY TO MASTER SWITCH LEAD (CIRCUIT 6) (M1064A3 ONLY) —**0358 00****Continued**

7. Install new grommet (8) on circuit 6 lead (1). Insert lead through hole in battery compartment and secure grommet in hole.
8. Install circuit 6P lead (9) followed by circuit 48 lead (10) on screw (11). Insert screw in terminal lug (12).
9. Install circuit 6 lead (1), circuit 778 lead (13) and circuit 772 lead (14) on terminal lug (12). Secure with nut (15).
10. Coat top of terminal lug (12) with grease.

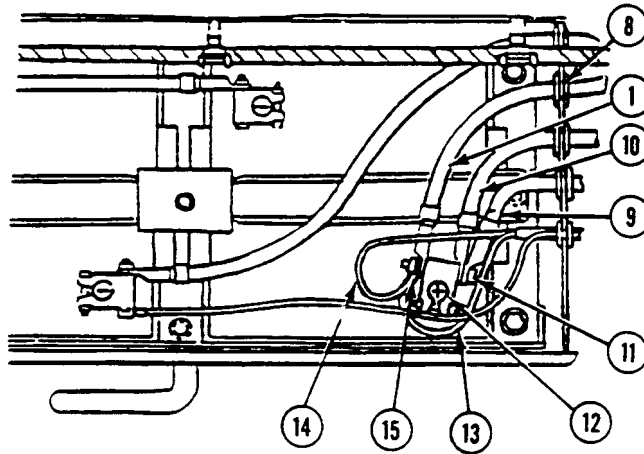
**FOLLOW-THROUGH STEPS**

1. Close battery drawer (see your -10).
2. Connect battery ground strap (WP 0337 00).
3. Start engine (see your -10).
4. Raise and lock ramp (see your -10).
5. Stop engine (see your -10).

END OF TASK

REPLACE ENGINE WIRING HARNESS

0359 00

THIS WORK PACKAGE COVERS:

- Removal (page 0359 00-2).
- Cleaning, Inspection, and Repair (page 0359 00-8).
- Installation (page 0359 00-8).

INITIAL SETUP:

Maintenance Level

Unit

Personnel Required

Unit Mechanic

Tools and Special Tools

- General Mechanic's Tool Kit (WP 0926 00, Item 65)
- Electrical Tool Kit (WP 0926 00, Item 64)
- Multimeter (WP 0926 00, Item 30)

References

See your -10

Materials/Parts

- Locknut (2)
- Lockwasher (3)
- Tie strap (3)
- Tie strap

Equipment Condition

- Engine stopped (see your -10)
 - Carrier blocked (see your -10)
 - Power plant removed (WP 0156 00)
-

REMOVAL

1. Disconnect lead (1) from transmission high oil temperature switch (2).

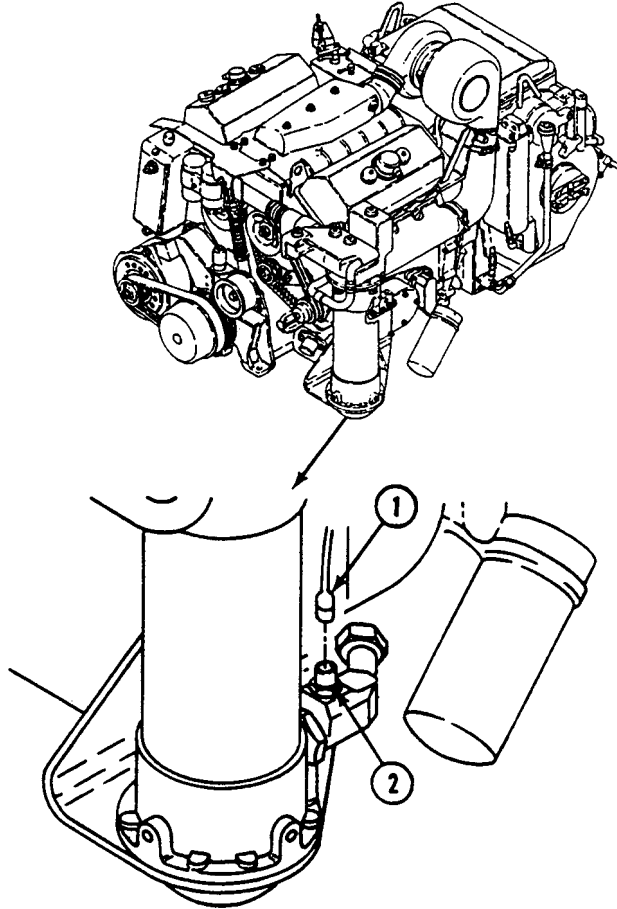

2. Disconnect lead (3) from coolant temperature sending unit (4).

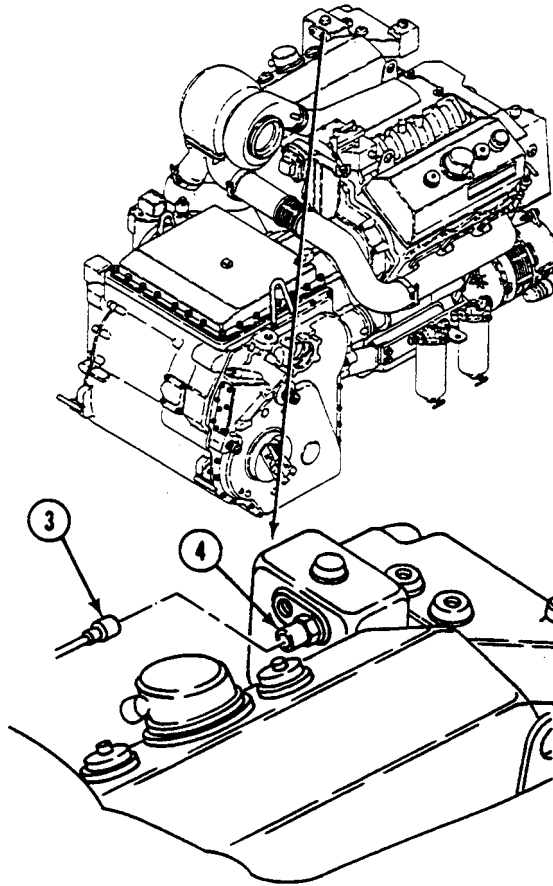

REPLACE ENGINE WIRING HARNESS — Continued**0359 00**

3. Remove screw (1), lockwasher (2), ground lead (3), and clamp (4) from bracket (5). Discard lockwasher.
4. Disconnect lead (6) from receptacle (7). Remove clamp (4) from lead.
5. Remove tie strap (8) from lead (9) and bracket (5). Discard tie strap.

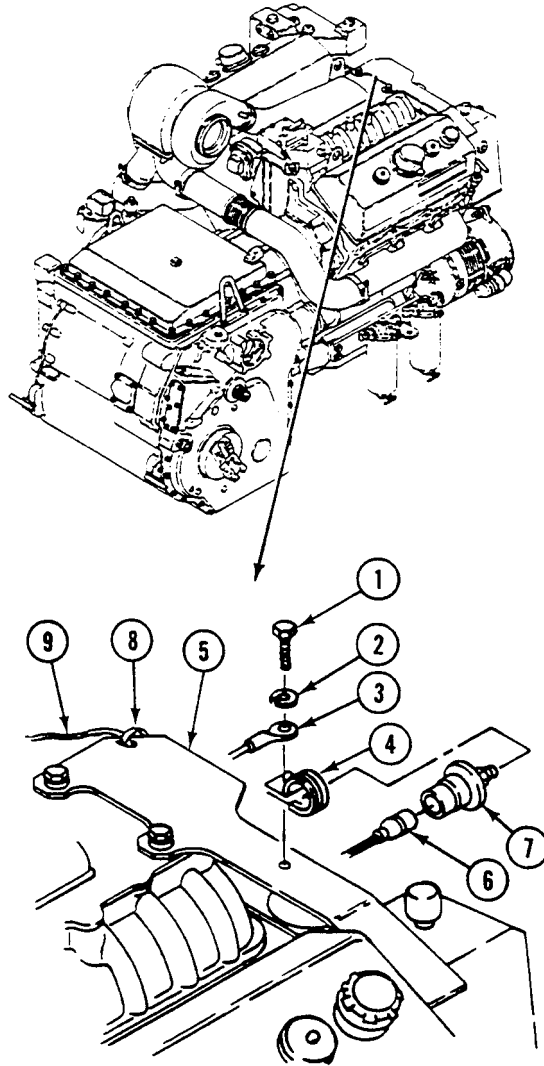

REPLACE ENGINE WIRING HARNESS — Continued

0359 00

6. Remove tie strap (10) from lead (11). Discard strap.
7. Disconnect cannon plug (12) from generator (13). If STE/ICE system is installed, disconnect two ground leads (14).
8. Disconnect two STE/ICE leads (15), (16) from generator main cable (17).

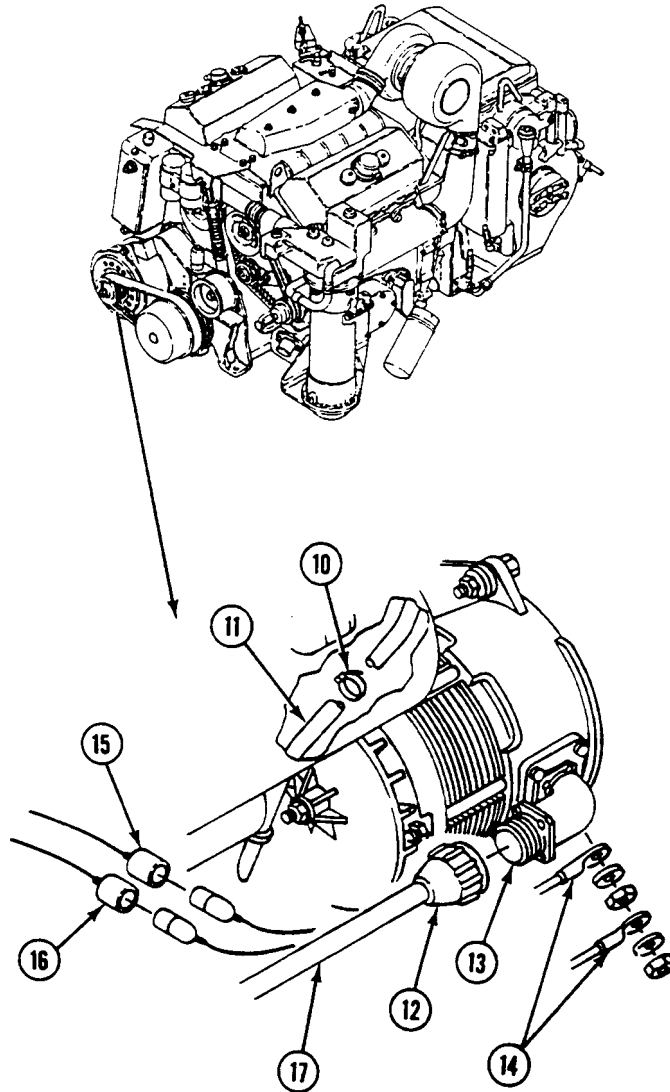

9. Remove nut (1), lockwasher (2), and two leads (3) from starter solenoid (4). Discard lockwasher.
10. Remove nut (5), lockwasher (6), and lead (7) from starter relay (8). Discard lockwasher.
11. Disconnect lead (9) from pressure switch (10).

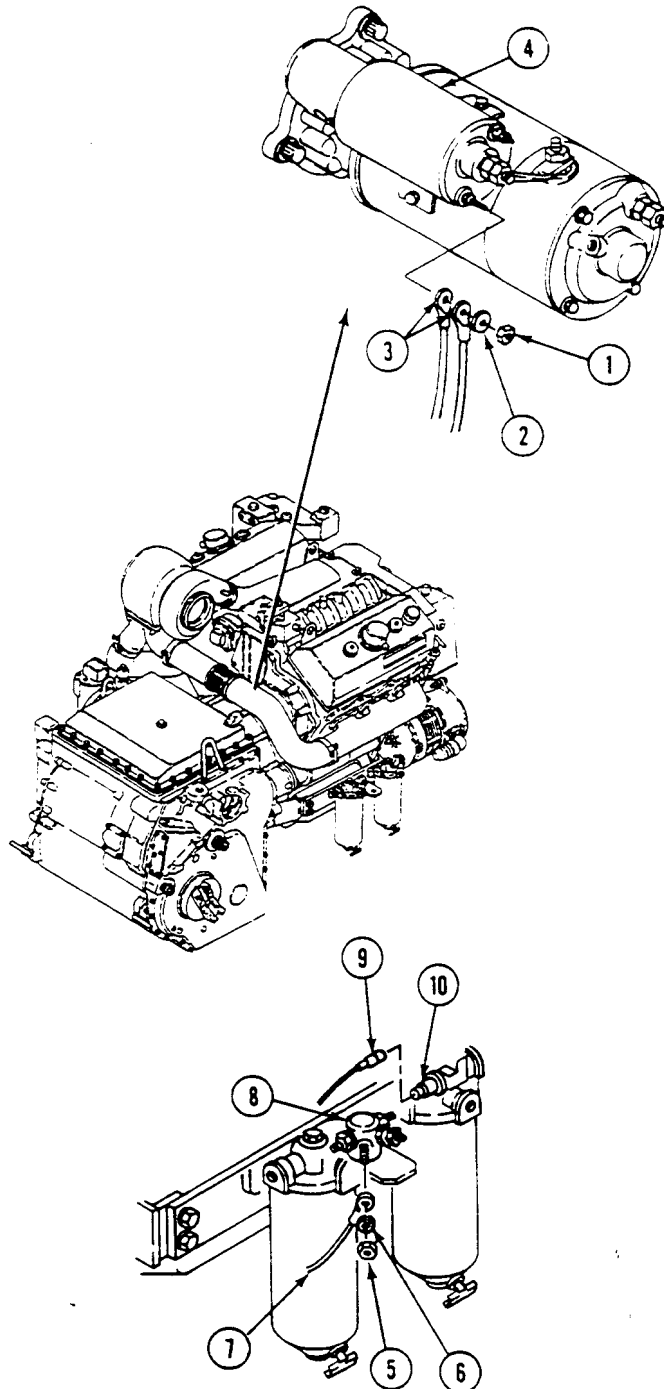

REPLACE ENGINE WIRING HARNESS — Continued

0359 00

12. Remove locknut (11), washer (12), screw (13), and clamp (14) from filter bracket (15). Remove clamp from harness (16). Discard locknut.
13. Remove locknut (17), washer (18), screw (19), and clamp (20) from bracket (21). Remove clamp from harness (16). Discard locknut.
14. Remove two straps (22) securing harness (16) to transmission oil line (23). Discard straps.

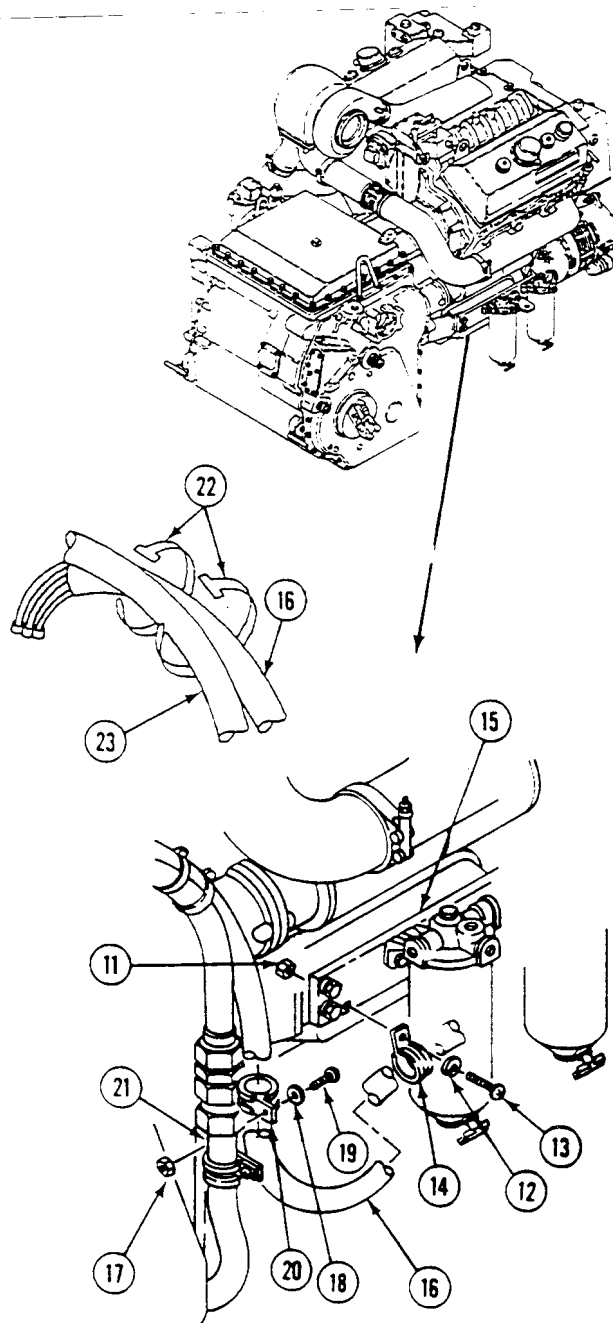

15. Disconnect lead (1) from oil pressure transmitter (2), and remove harness (3) from power plant.

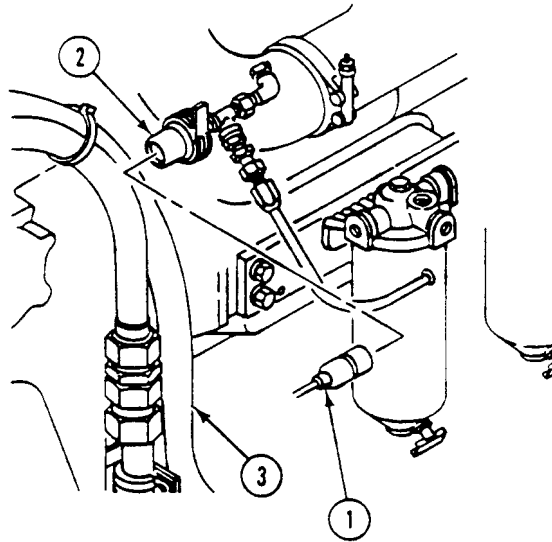

CLEANING

CLEANING, INSPECTION, AND REPAIR

1. Check harness for continuity.
2. Check leads. Replace frayed, cracked, or broken leads (WP 0382 00).
3. Check connectors.

INSTALLATION

1. Connect lead (1) to oil pressure transmitter (2).

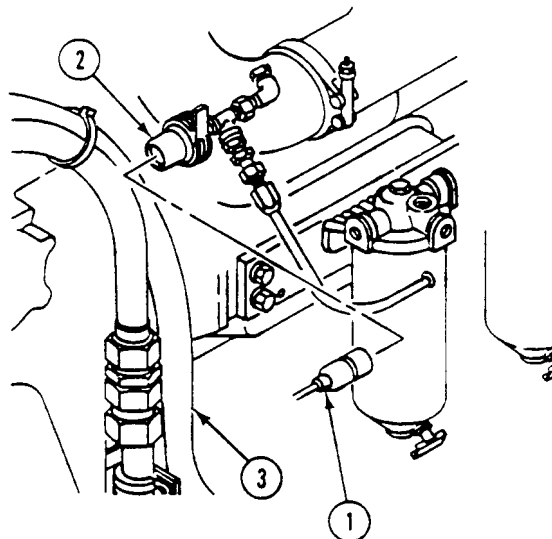

2. Install clamp (4) on harness (3). Secure clamp to bracket (5) with screw (6), washer (7), and new locknut (8).
3. Install clamp (9) on harness (3). Secure clamp to filter bracket (10) with screw (11), washer (12), and new locknut (13).
4. Secure harness (3) to transmission oil line (14) with two new straps (15).

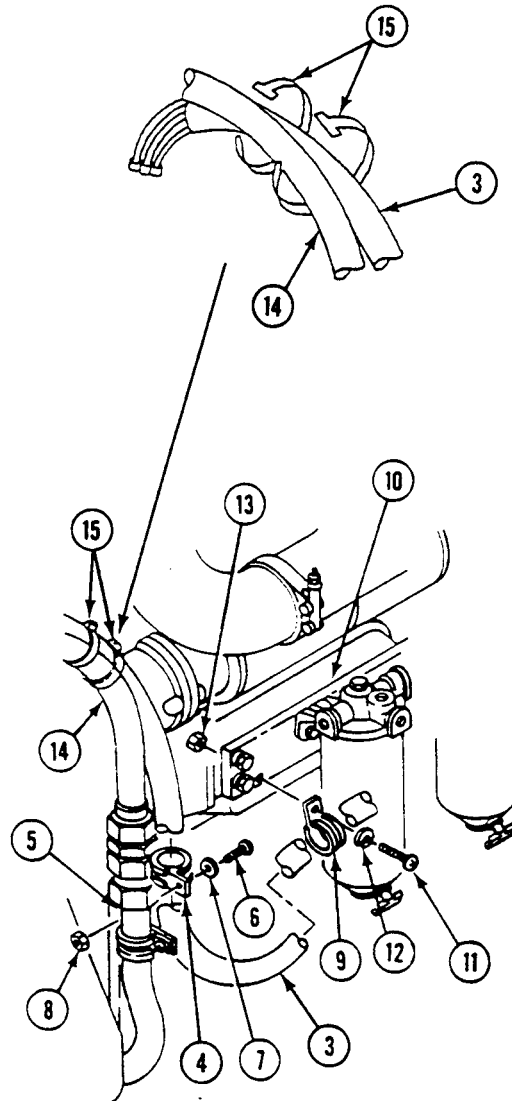

REPLACE ENGINE WIRING HARNESS — Continued

0359 00

5. Connect lead (1) to pressure switch (2).
6. Install lead (3) on starter relay (4) terminal. Secure with nut (5) and new lockwasher (6).
7. Install two leads (7) on starter solenoid (8) terminal (9). Secure with nut (10) and new lockwasher (11).

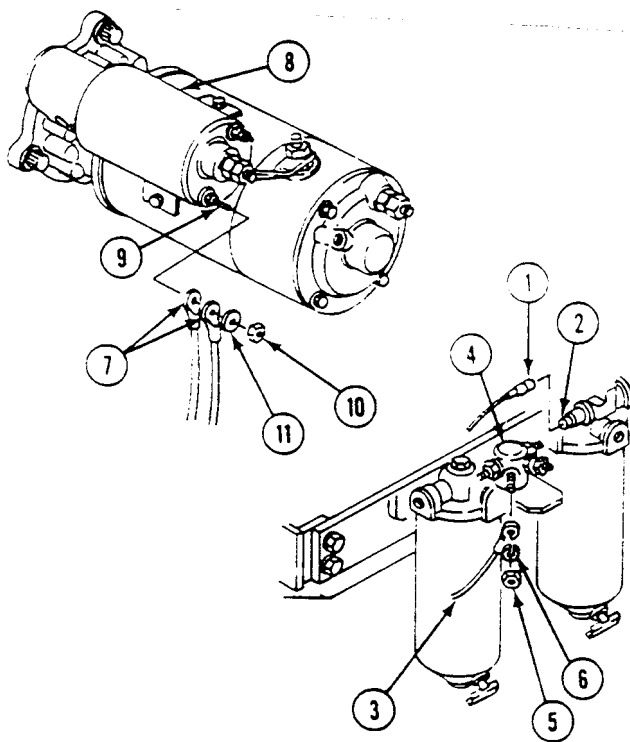

REPLACE ENGINE WIRING HARNESS — Continued

0359 00

8. Connect lead (12) to generator (13). If STE/ICE system was installed, reconnect two ground leads (14).
9. Install new tie strap (15) on lead (12).
10. Connect two STE/ICE leads (16), (17) to generator main cable (18).

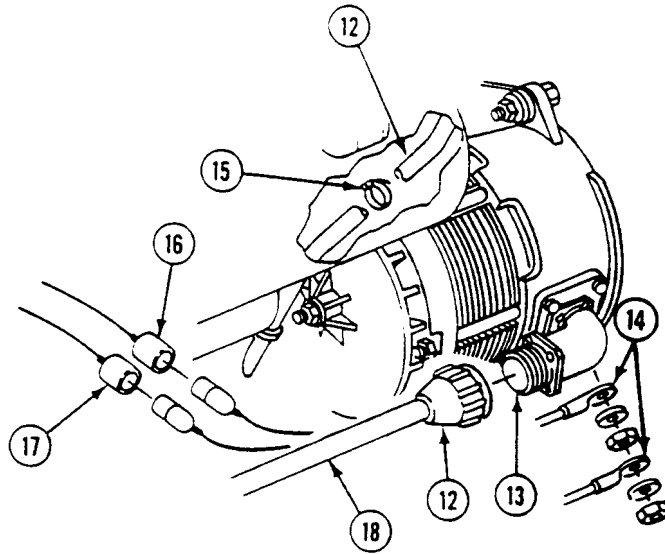

11. Install clamp (19) on lead (20). Connect lead to receptacle (21).
12. Install ground lead (22) and clamp (19) on bracket (23). Secure with screw (24) and new lockwasher (25).

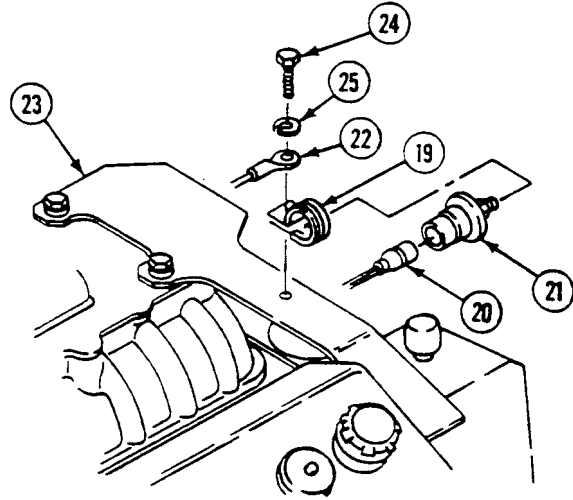

13. Connect lead (1) to coolant temperature sending unit (2).

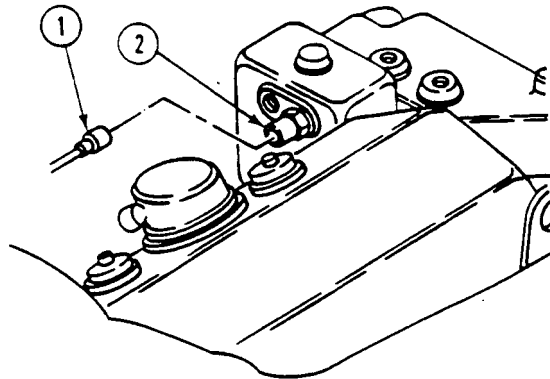

14. Connect lead (3) on transmission high oil temperature switch (4).

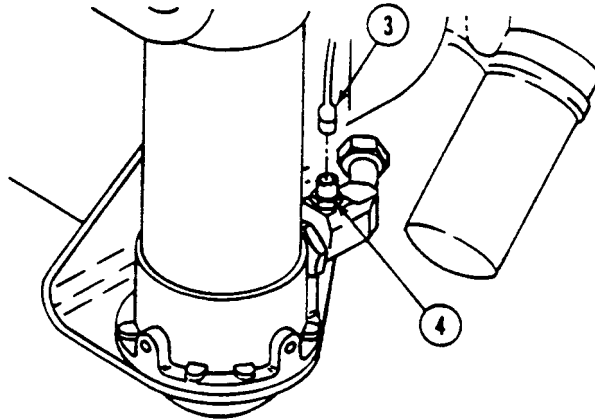

15. Install lead (5) on bracket (6), and secure with new tie strap (7).

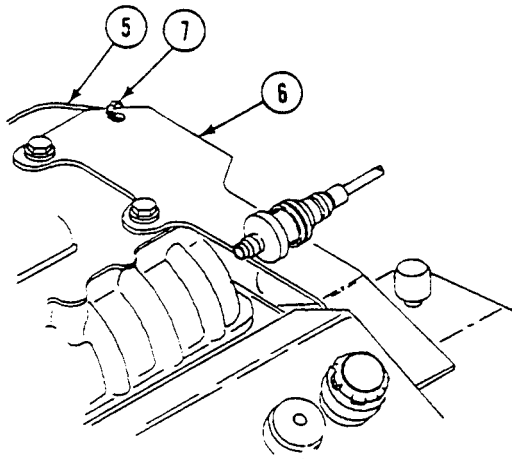

FOLLOW-THROUGH STEPS

1. Install power plant (WP 0156 00).

END OF TASK

REPLACE VARIABLE SPEED FAN DRIVE WIRING HARNESS, 3W1 (NEW CONFIGURATION)

0359 01

THIS WORK PACKAGE COVERS:

Removal (WP 0359 01-1).

Installation (WP 0359 01-2).

INITIAL SETUP:

Maintenance Level

Unit

Tools and Special Tools

General Mechanic's Tool Kit (WP 0926, Item 65)

Materials/Parts

Tie straps

Personnel Required

Unit Mechanic

References

See your -10

Equipment Conditions

Engine stopped (see your -10)

Carrier blocked (see your -10)

Power plant rear access panels removed (see your -10)

Driver's power plant access panel removed (see your -10)

Battery ground strap disconnected (WP 0337 00 or WP 0338 00)

REMOVAL

1. Disconnect tie straps (1) as needed to remove wiring harness from engine.
2. Disconnect plug P1 (2) and plug P2 (3) from variable speed fan controller jacks J1 (4) and J2 (5).

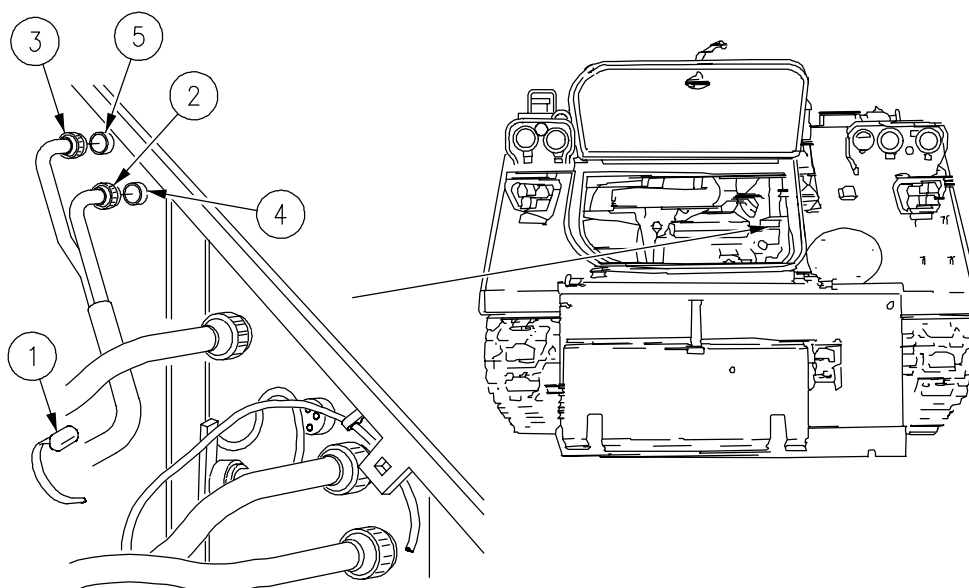

- Continued

3. Disconnect lead E1 (6) and lead E2 (7) from starter (8).
4. Disconnect plug P3 (9) from engine running switch S2 (10).

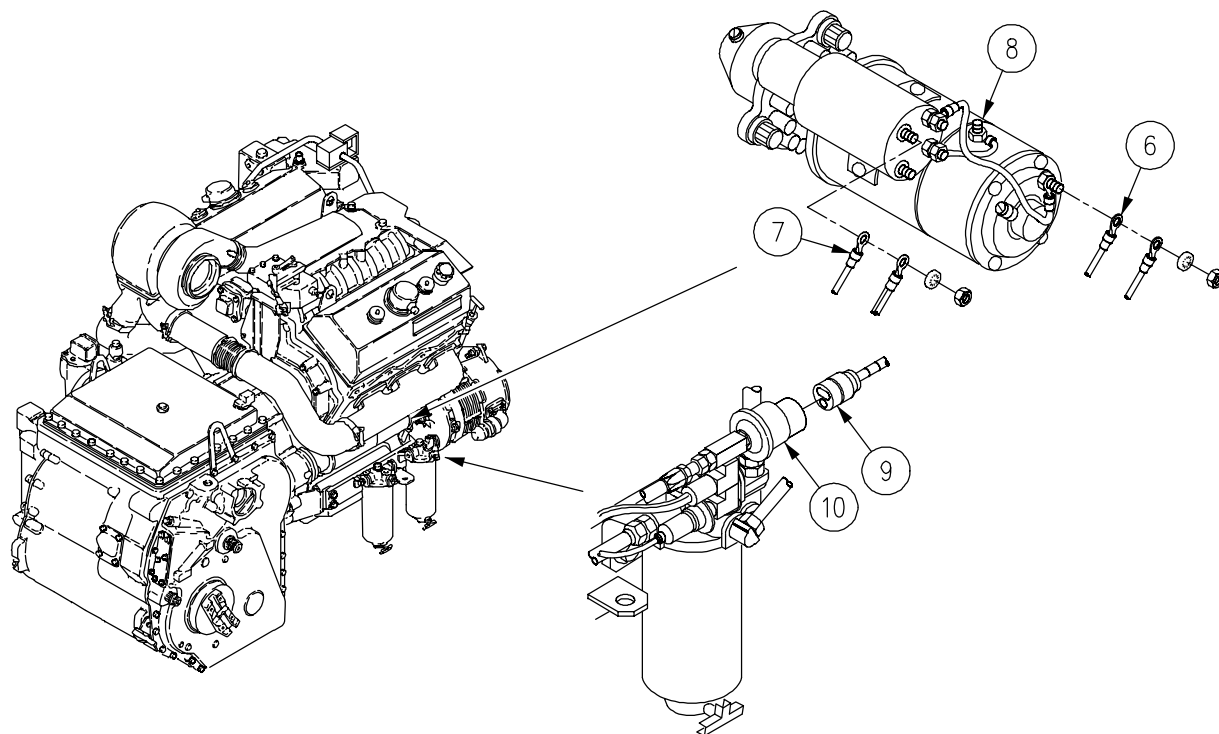

5. Disconnect plug P4 (11) from fan clutch 3A1 (12) and plug P5 (13) from fan speed sensor 3A2 (14) on variable speed fan drive (15).
6. Disconnect lead E3 (16) and lead E4 (17) from fan override switch (18).
7. Disconnect plug P6 (19) from engine coolant sensor 3A3 (20).

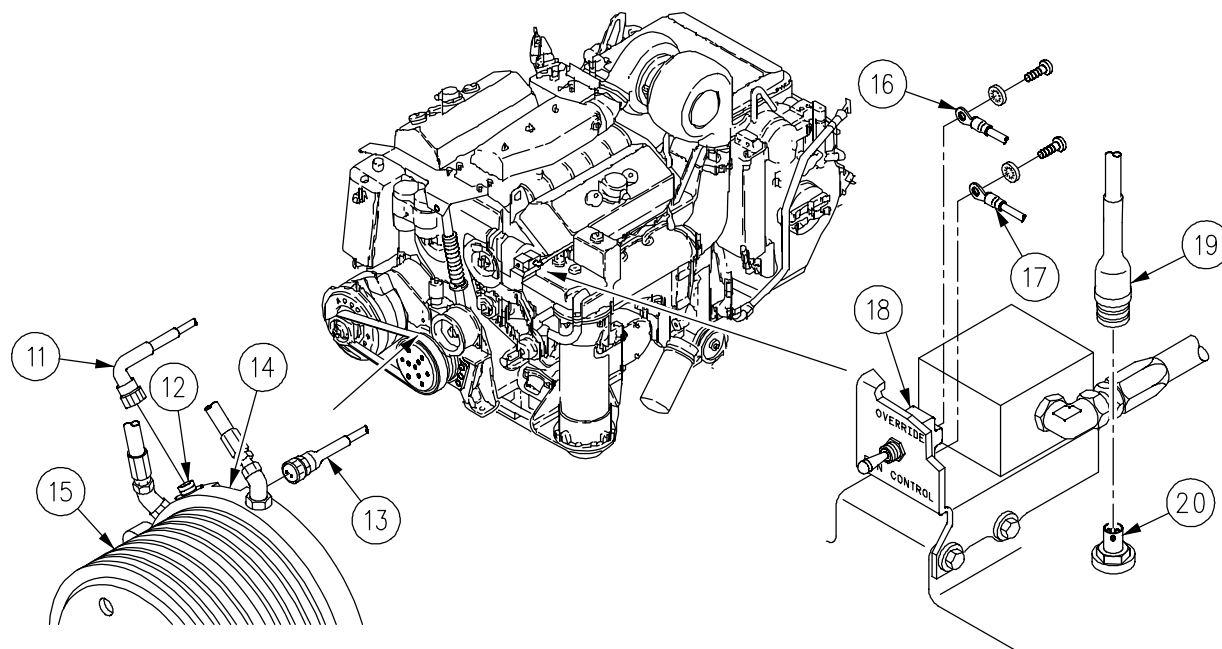

INSTALLATION

1. Connect plug P6 (19) on engine coolant sensor 3A3 (20).
2. Connect lead E3 (16) and lead E4 (17) on fan override switch (18).
3. Connect plug P4 (11) on fan clutch 3A1 (12) and plug P5 (13) on fan speed sensor 3A2 (14) on variable speed fan drive (15).

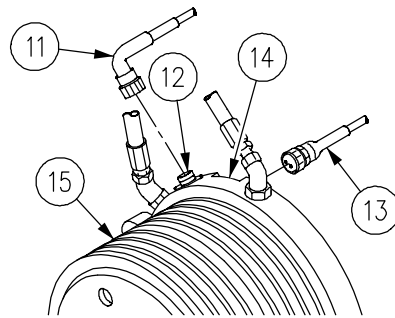
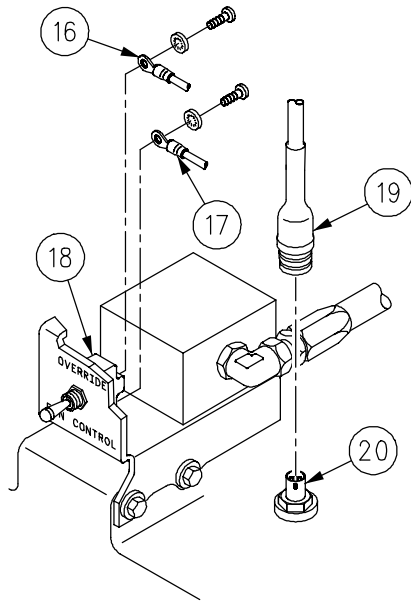

4. Connect plug P3 (9) on engine running switch S2 (10)
5. Connect lead E1 (6) and lead E2 (7) on starter (8).

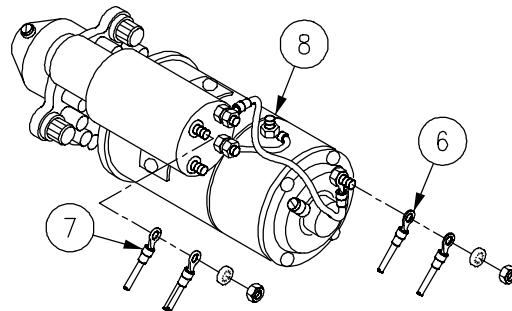
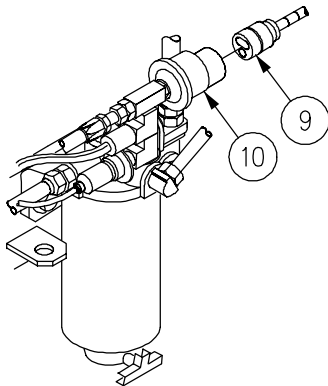

REPLACE VARIABLE SPEED FAN DRIVE WIRING HARNESS, 3W1 (NEW CONFIGURATION)
- Continued

0359 01

6. Connect plug P1 (2) and plug P2 (3) on variable speed fan controller jacks J1 (4) and J2 (5).
7. Install new tie straps (1) as required to secure wiring harness to engine.

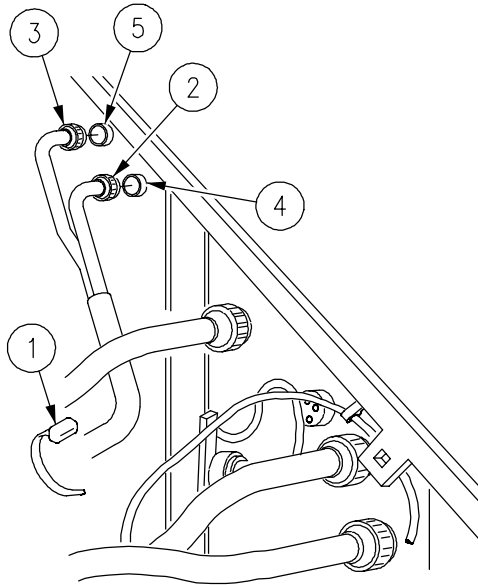
**FOLLOW-THROUGH STEPS**

1. Connect battery ground strap (WP 0337 00 or WP 0338 00).
2. Install driver's power plant access panel (see your-10).
3. Install power plant rear access panels (see your-10).

END OF TASK

REPLACE TRANSMISSION WIRING HARNESS

0360 00

THIS WORK PACKAGE COVERS:

- Removal (page 0360 00-1).
- Inspection and Repair (page 0360 00-2).
- Installation (page 0360 00-2).

INITIAL SETUP:

Maintenance Level
Unit

References
See your -10

Tools and Special Tools
General Mechanic's Tool Kit (WP 0926 00, Item 65)
Multimeter (WP 0926 00, Item 30)

Equipment Condition

- Engine stopped (see your -10)
- Carrier blocked (see your -10)
- Trim vane lowered (see your -10)
- Power plant access door opened (see your -10)

Materials/Parts

Locknut (4)

Personnel Required

Unit Mechanic

REMOVAL

1. Disconnect transmission wiring harness connector (1) from bulkhead connector (2).
2. Disconnect circuit 366 lead (3) from transmission low oil level pressure switch (4).
3. Disconnect wiring harness connector (5) from transmission connector (6).
4. Disconnect circuit 323 connector (7) from differential pressure switch (8).
5. Remove four screws (9), eight washers (10), four locknuts (11), and four clamps (12) from brackets and wiring harness (13). Discard locknuts.
6. Remove wiring harness (13) from transmission.

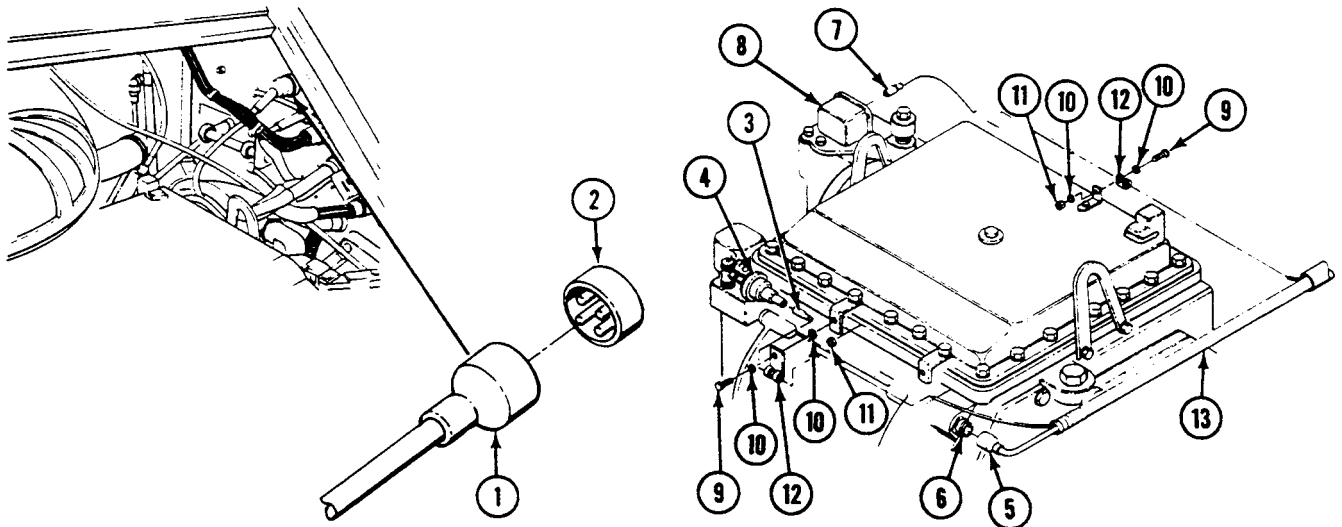

INSPECTION-ACCEPTANCE AND REJECTION CRITERIA**INSPECTION AND REPAIR**

1. Check leads for continuity. Replace bad leads.
2. Check connectors and terminals. Repair bad connectors or terminals (WP 0382 00).

INSTALLATION

1. Place new wiring harness (1) on transmission.
2. Connect circuit 323 connector (2) to differential pressure switch (3).
3. Connect wiring harness connector (4) to transmission connector (5).
4. Connect circuit 366 lead (6) to transmission low oil pressure switch (7).
5. Connect transmission wiring harness connector (8) to bulkhead connector (9).
6. Install wiring harness (1) in four clamps (10), and secure to brackets with four screws (11), eight washers (12), and four new locknuts (13).

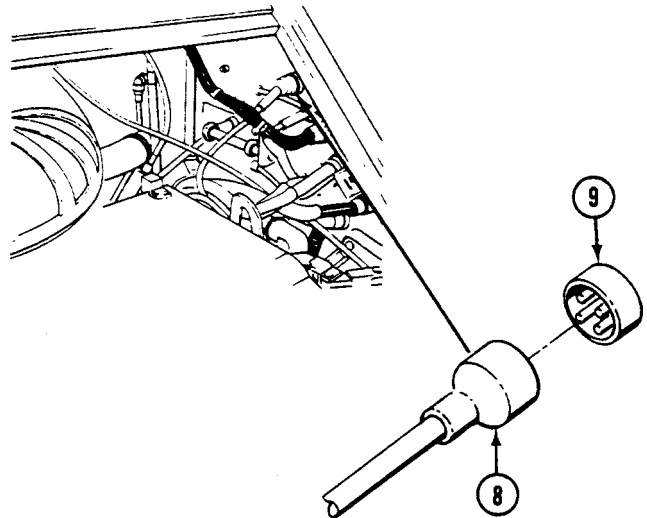
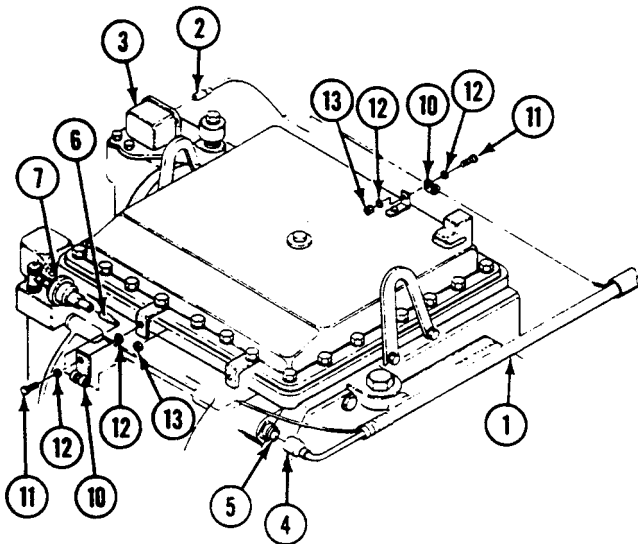
**FOLLOW-THROUGH STEPS**

1. Close power plant access door (see your -10).
2. Raise trim vane (see your -10).

END OF TASK

REPLACE TRANSMISSION CONTROLLER WIRING HARNESS

0361 00

THIS WORK PACKAGE COVERS:

- Removal (page 0361 00-1).
- Inspect and Repair (page 0361 00-4).
- Installation (page 0361 00-4).

INITIAL SETUP:

Maintenance Level
Unit

References
See your -10

Tools and Special Tools
General Mechanic's Tool Kit (WP 0926 00, Item 65)
Multimeter (WP 0926 00, Item 30)

Equipment Condition

- Engine stopped (see your -10)
- Carrier blocked (see your -10)
- Trim vane lowered (see your -10)
- Power plant access door opened (see your -10)
- Driver's power plant access panel removed (see your -10)
- Battery ground strap disconnected (WP 0337 00), (WP 0338 00), or (WP 0339 00)

Materials/Parts
Locknut (2)
Locknut
Locknut (4)
Lockwasher
Lockwasher (3)
Personnel Required
Unit Mechanic
Helper (H)

REMOVAL

1. Remove two locknuts (1), mounts (2), (3), washers (4), and screws (5) that secure instrument panel (6) to two struts (7). Discard locknuts.
2. Support instrument panel. Remove two screws (8), washers (9), ground lead (10), and lockwasher (11) from instrument panel (6) and upper support (12). Discard lockwasher.

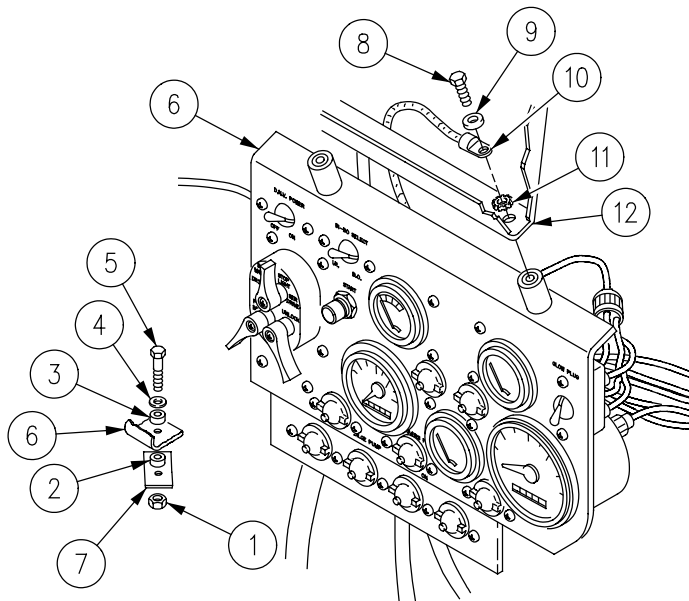

3. Remove screw (1), locknut (2), washer (3), and two ground leads (4)(5) from strut (6). Discard locknut.

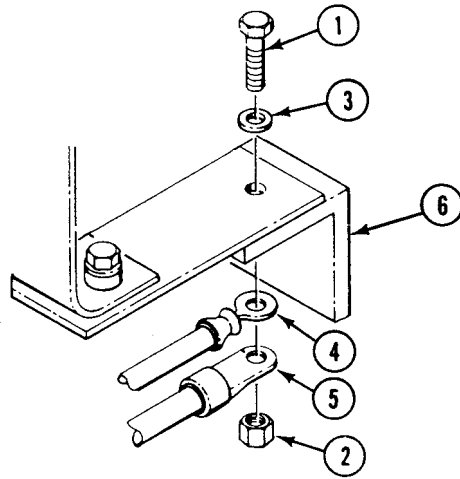

NOTE

Support instrument panel on two struts to gain access to rear of panel.

4. Disconnect circuit 40 lead (6) from instrument panel wiring harness lead (7).
5. Disconnect circuit 27P lead (8) from instrument panel wiring harness lead (9).
6. Disconnect circuit 323 lead (10) from transmission filter clogged indicator (11) on instrument panel.

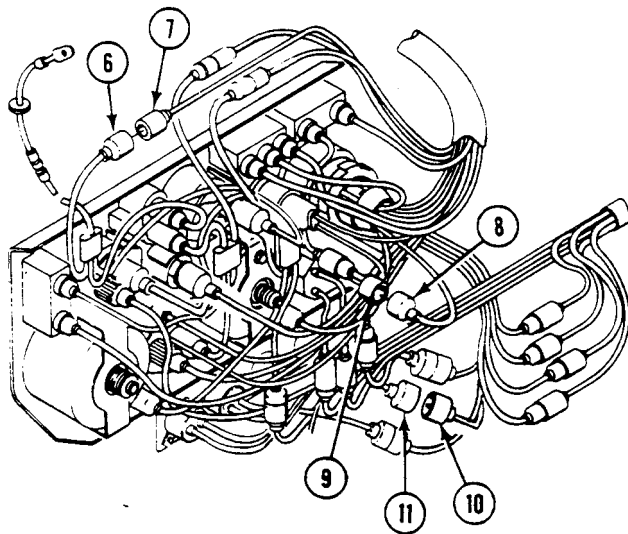

7. Disconnect circuit 366 lead (12) from front main wiring harness circuit 366 lead (13).

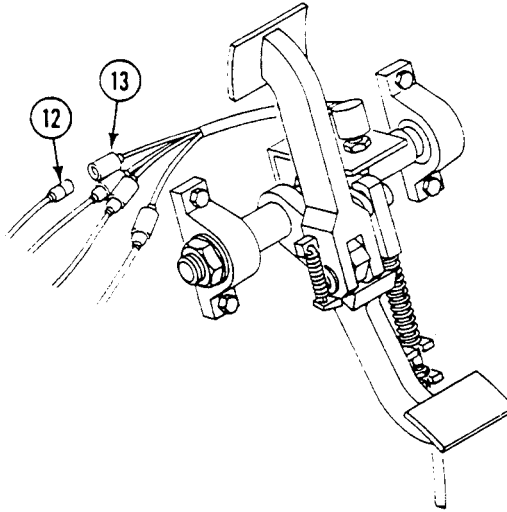

8. Disconnect circuit 14B lead (14) from front main wiring harness circuit 14 lead (15).

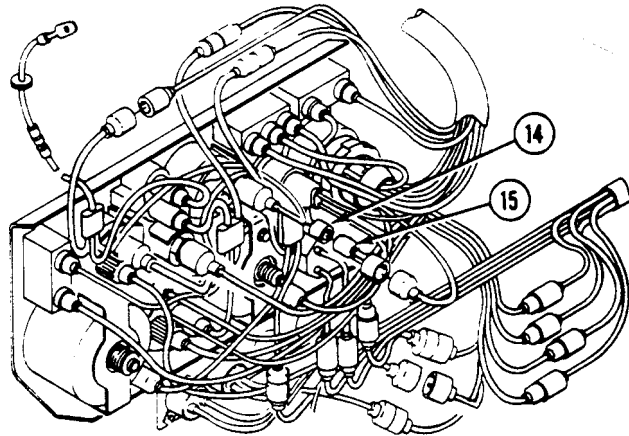

9. Disconnect circuit 368 lead (16) from steering lock switch wiring harness lead (17).

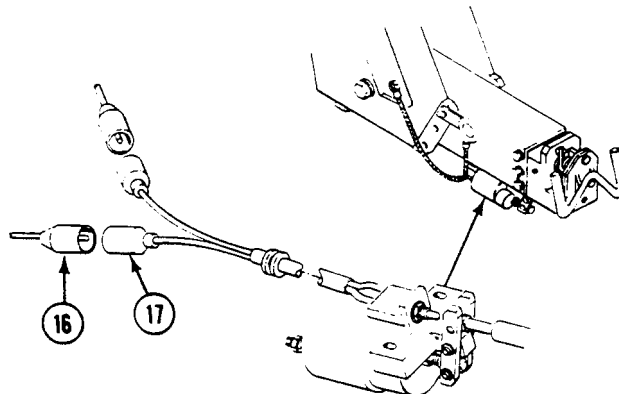

10. Remove three screws (1), lockwashers (2), clamps (3), and wiring harness (4) from driver's front hull. Discard lockwashers.
11. Disconnect wiring harness connector (6) from transmission control (5).
12. Disconnect transmission wiring harness (7) from bulkhead connector located inside power plant compartment.
13. Remove four screws (8), locknuts (9), and connector (10) from driver's compartment bulkhead. Have helper assist. Discard locknuts.
14. Remove transmission controller wiring harness (11).

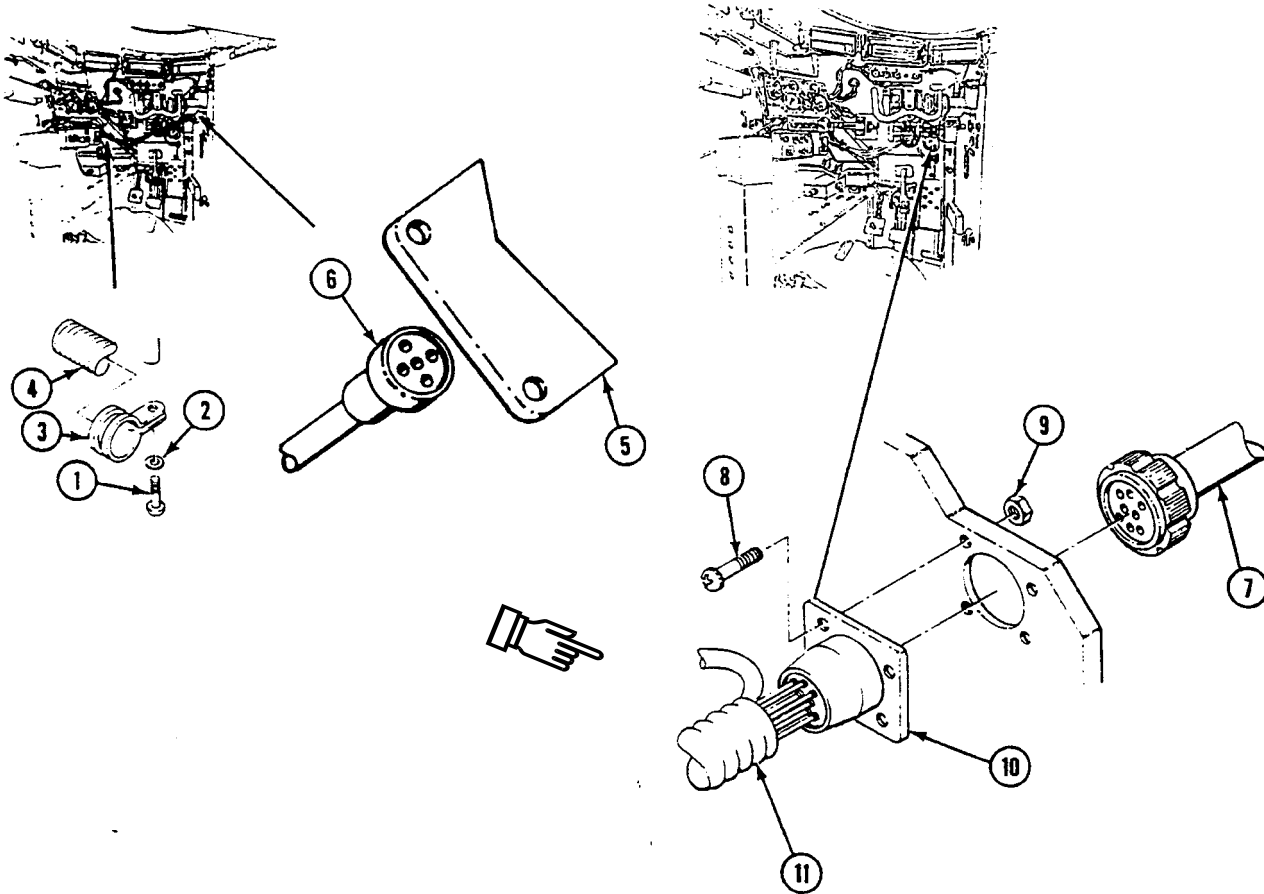

INSPECT AND REPAIR

1. Check harness continuity. Replace bad harness.
2. Check leads. Replace frayed, cracked, or broken leads (WP 0382 00).
3. Check connectors. Replace cracked or broken connectors (WP 0382 00).

INSTALLATION

1. Place transmission controller wiring harness (11) in position near mating connectors.
2. Install transmission controller wiring harness connector (10), four new locknuts (9), and screws (8) on driver's compartment bulkhead. Have helper assist.

REPLACE TRANSMISSION CONTROLLER WIRING HARNESS — Continued

0361 00

3. Connect transmission wiring harness (7) to bulkhead connector located inside power plant compartment.
4. Connect wiring harness connector (6) to transmission controller (5).

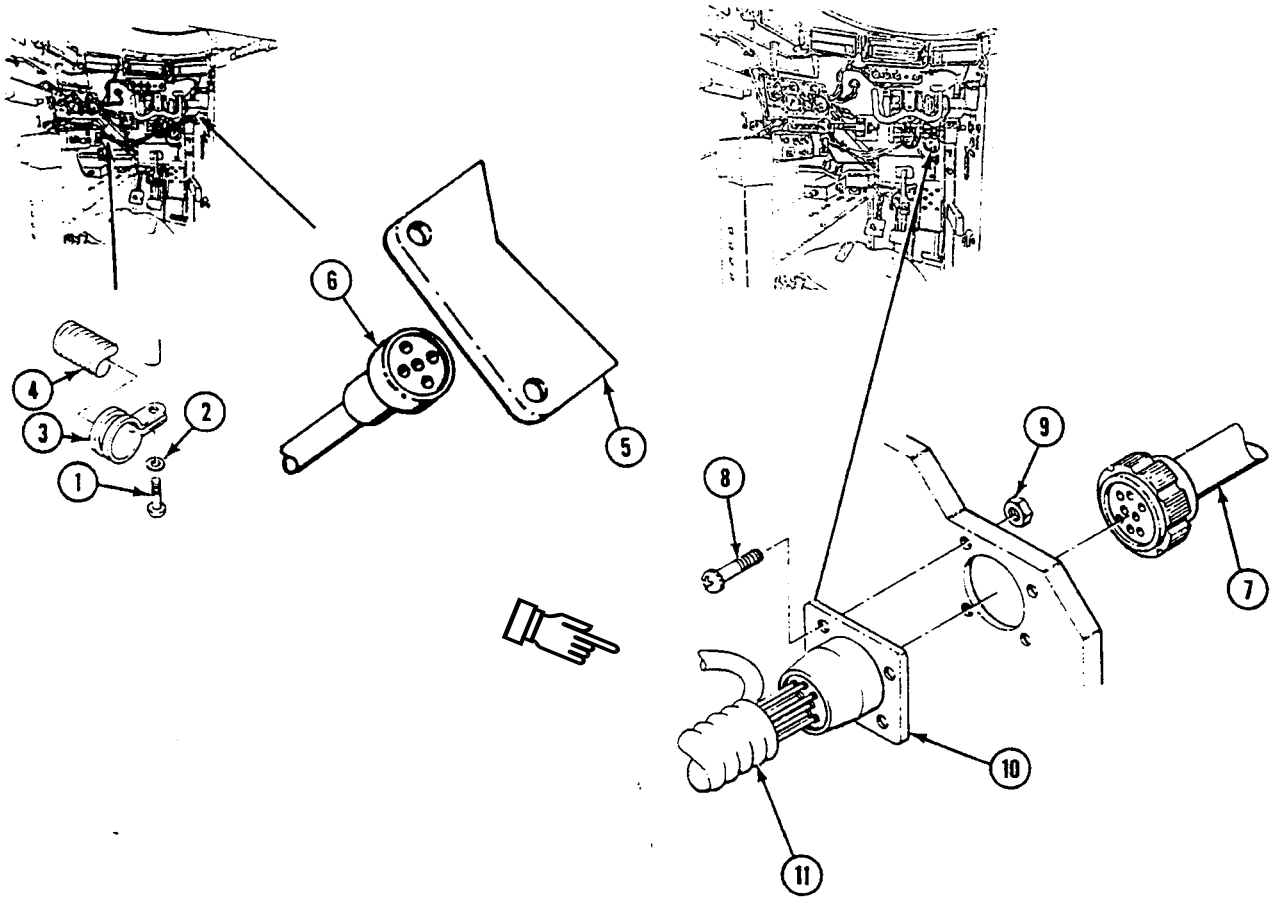

5. Connect circuit 368 lead (1) to steering lock switch wiring harness lead (2).

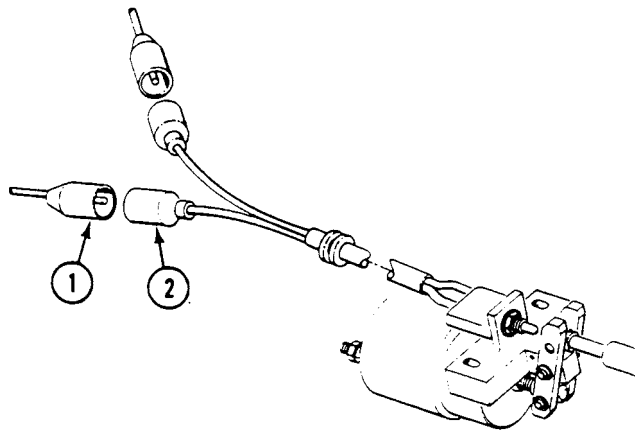

6. Connect circuit 14B lead (3) to circuit 14 lead (4) on front main wiring harness.

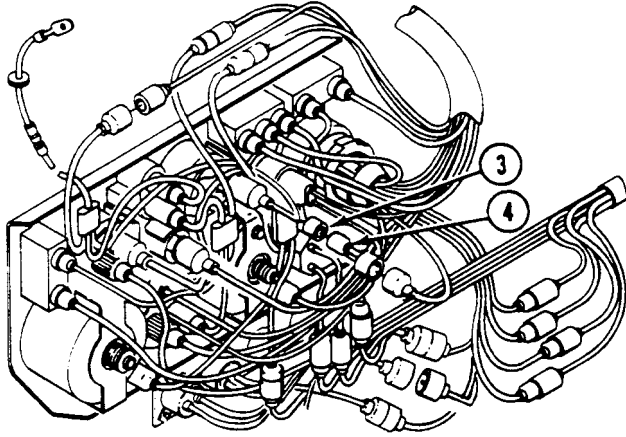

7. Connect circuit 366 lead (5) to circuit 366 lead (6) on front main wiring harness.

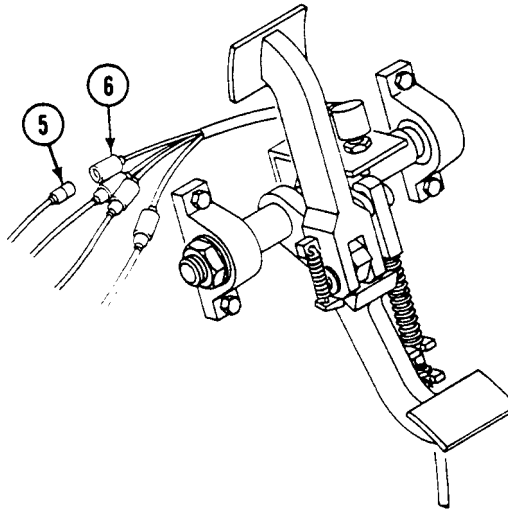

8. Connect circuit 323 lead (7) to transmission filter clogged indicator (8) on instrument panel.
9. Connect circuit 27P lead (9) to instrument panel wiring harness lead (10).
10. Connect circuit 40 lead (11) to instrument panel wiring harness lead (12).

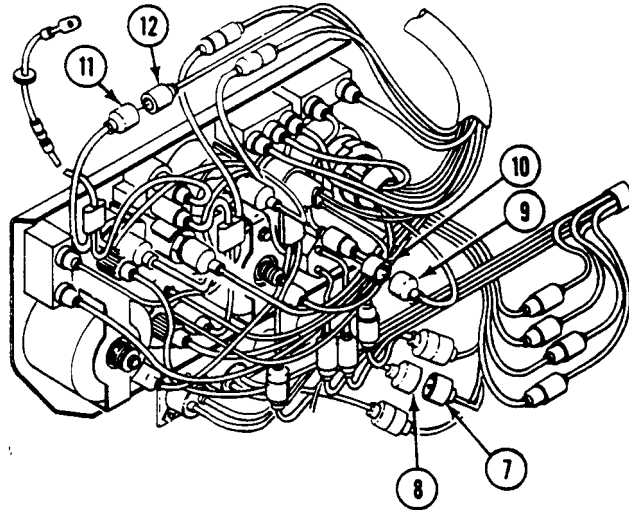

NOTE

Support instrument panel on two struts during installation of panel.

11. Install two ground leads (4)(5), washer (3), screw (1), and new locknut (2) on strut (6).

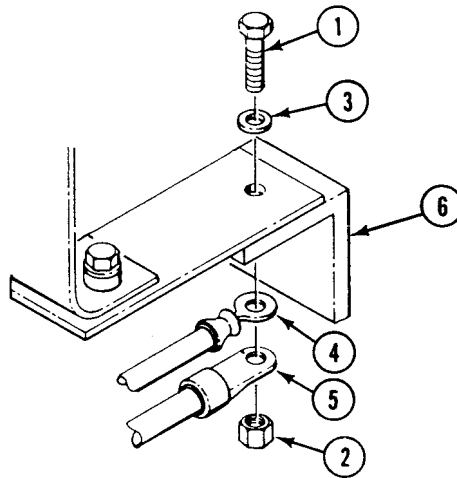

12. Install instrument panel (6) and ground lead (7) on support (8). Secure with new lockwasher (9), two washers (10), and screws (11).
13. Install instrument panel (6) on two struts (12). Secure with two new locknuts (13), mounts (14)(15), washers (16), and screws (17).

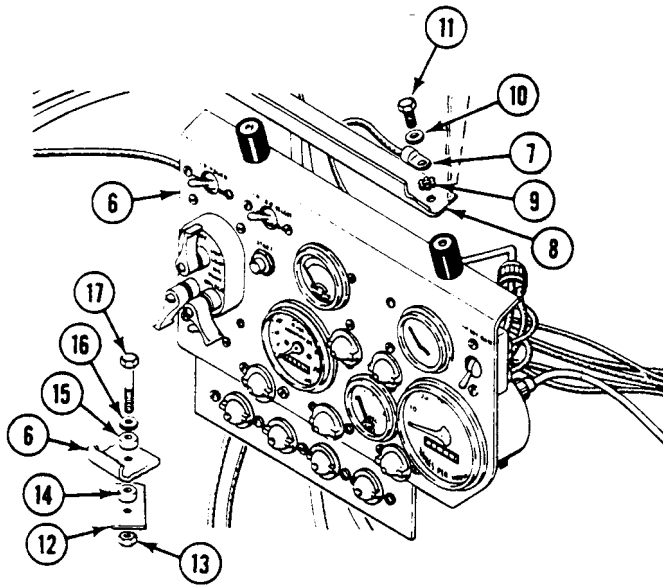

14. Install wiring harness (18), three clamps (19), new lockwashers (20), and screws (21) on driver's front hull.

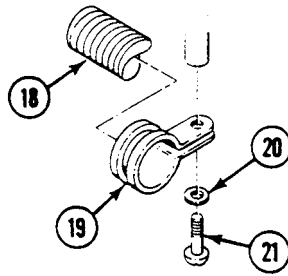

FOLLOW-THROUGH STEPS

1. Connect battery ground strap (WP 0337 00), (WP 0338 00), or (WP 0339 00).
2. Install driver's power plant access panel (see your -10).
3. Close power plant access door (see your -10).
4. Raise trim vane (see your -10).
5. Start engine (see your -10). Check that transmission controller works right.
6. Stop engine (see your -10).

END OF TASK

REPLACE REAR MAIN WIRING HARNESS (M113A3, M1059A3, AND M58)

0362 00 ■

THIS WORK PACKAGE COVERS:

- Removal (page 0362 00-2).
- Inspect and Repair (page 0362 00-21).
- Installation (page 0362 00-21).

INITIAL SETUP:

Maintenance Level

Unit

References

See your -10

Tools and Special Tools

General Mechanic's Tool Kit (WP 0926 00, Item 65)

Equipment Condition

- Engine stopped (see your -10)
- Carrier blocked (see your -10)
- Ramp lowered (see your -10)
- Rear floor plate removed (see WP 0539 00, WP 0542 00, WP 0545 00)
- Battery ground strap disconnected (WP 0337 00)
- Smoke generator fog oil tank module removed (M1059A3 only) (WP 0753 00)

Materials/Parts

- Adhesive sealant (WP 0928 00, Item 6)
- Locknut (9)
- Lockwasher (24)
- Tie strap

Personnel Required

Unit Mechanic

REPLACE REAR MAIN WIRING HARNESS (M113A3, M1059A3, AND M58) — Continued

0362 00

REMOVAL**NOTE**

M58 vehicle has a smoke system operator dome light on left side of carrier.

1. Disconnect circuit 38 lead (1) from right dome light (2). (Left dome light M58 only.)
2. Remove screw (3), clamp (4), nut (5), and circuit 38 lead (1) from right dome light bracket (6). (Left dome light M58 only.)
3. Remove three screws (7) and clamps (8) from weldnuts and circuit 38 lead (1) (M113A3 and M1059A3 only).

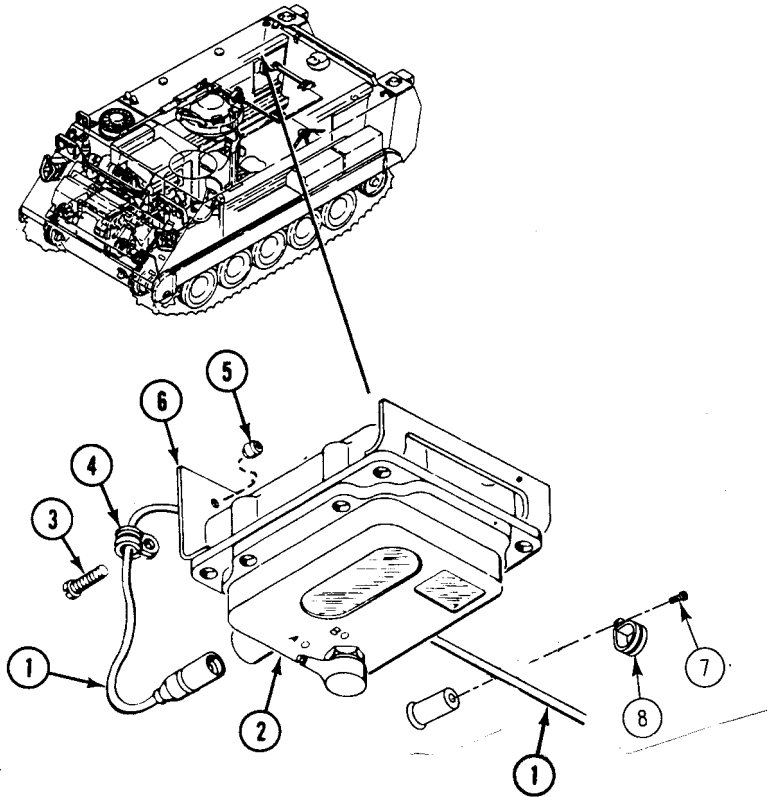

REPLACE REAR MAIN WIRING HARNESS (M113A3, M1059A3, AND M58) — Continued

0362 00 ■

4. Disconnect circuit 23 and 24 leads (1)(2) from right tail light (3)

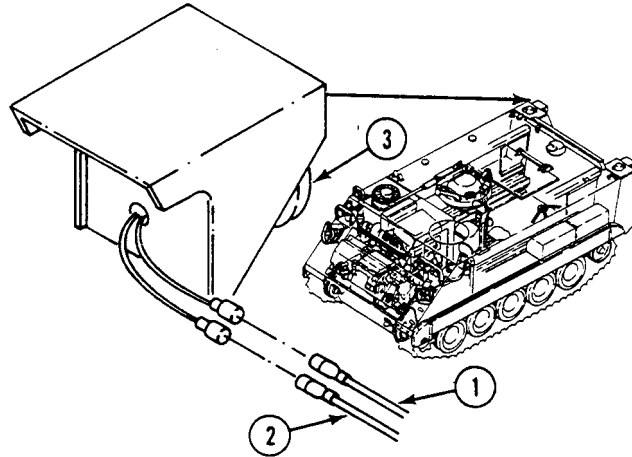

5. Disconnect circuit 31 lead (4) from right fuel transmitter (5) on fuel tank (6).

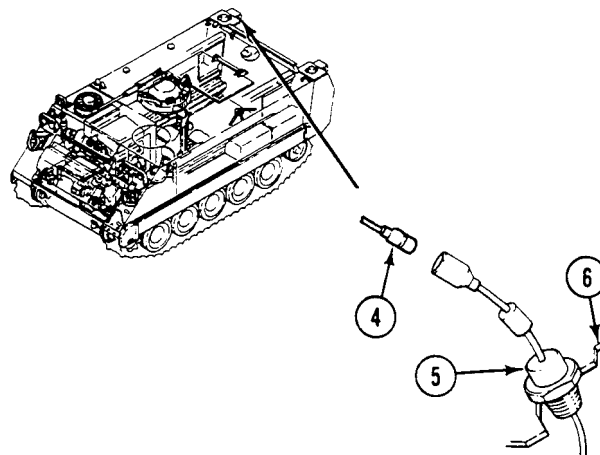

REPLACE REAR MAIN WIRING HARNESS (M113A3, M1059A3, AND M58) — Continued

0362 00

- Remove two screws (7), lockwashers (8), and washers (9) that secure harness guard (10) on top of right fuel tank (11). Remove guard from tank. Discard lockwashers.

NOTE

Step 7 is for M113A3 and M1059A3 only. For M58 only, see Replace Antenna Support (WP 0710 00).

- Remove two screws (12), lockwashers (13), and washers (14) that secure harness bracket (15) on top of right fuel tank (11). Remove bracket from tank. Discard lockwashers.

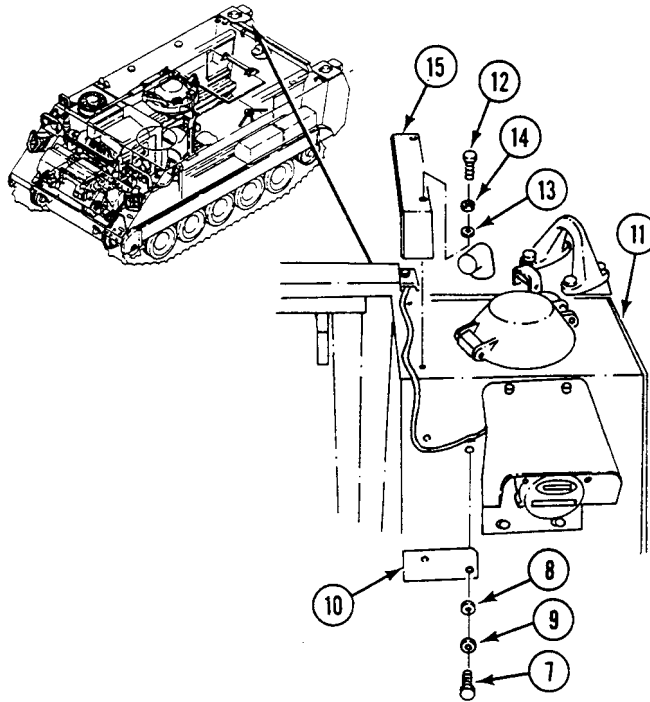

REPLACE REAR MAIN WIRING HARNESS (M113A3, M1059A3, AND M58) — Continued

0362 00 ■

8. Remove screw (16), lockwasher (17), and washer (18) that secure harness guard (19) on top of rear hull. Remove guard from hull. Discard lockwasher.

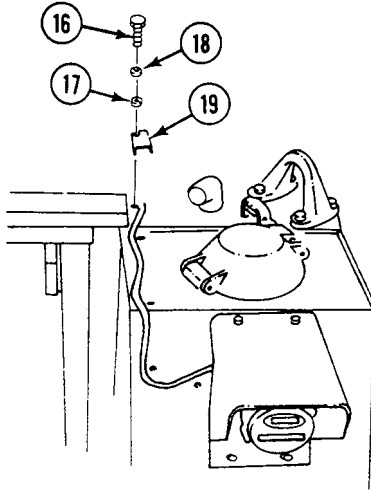

NOTE

Do Step 9 for M58 only.

9. Remove four screws (3), lockwashers (4), washers (2), and harness access cover (1) from top of rear hull. Discard lockwashers (M58 only).

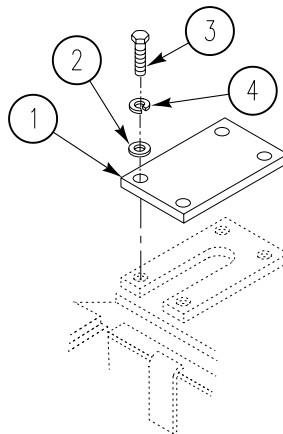

REPLACE REAR MAIN WIRING HARNESS (M113A3, M1059A3, AND M58) — Continued

0362 00

NOTE

The M58 does not use connector, bushing, and hardware only adhesive sealant on wiring harness in hull opening. To remove leads on M58, carefully cut adhesive sealant and pull harness into carrier.

10. Loosen nut (1) that secures circuits 23 (2), 24 (3), and 31 (4) leads with rubber bushing (5) in connector (6). Separate nut, washer (7), and rubber bushing from connector. (All except M58).
11. Remove connector (6) and harness from top of hull. Pull harness into carrier.

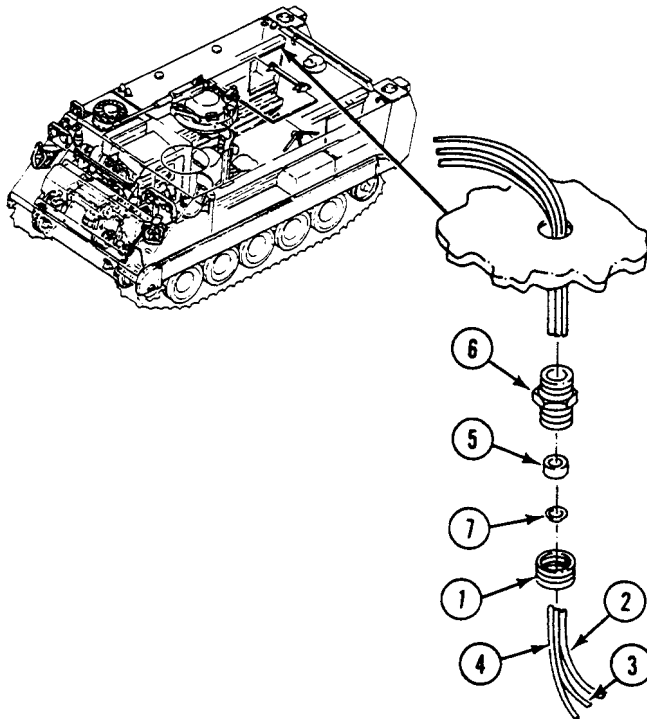

REPLACE REAR MAIN WIRING HARNESS (M113A3, M1059A3, AND M58) — Continued

0362 00 ■

12. Remove screw (8), nut (9), and clamp (10) that secures harness (11) on bilge pump tube clamp (12). Remove harness from bilge pump tube clamp.

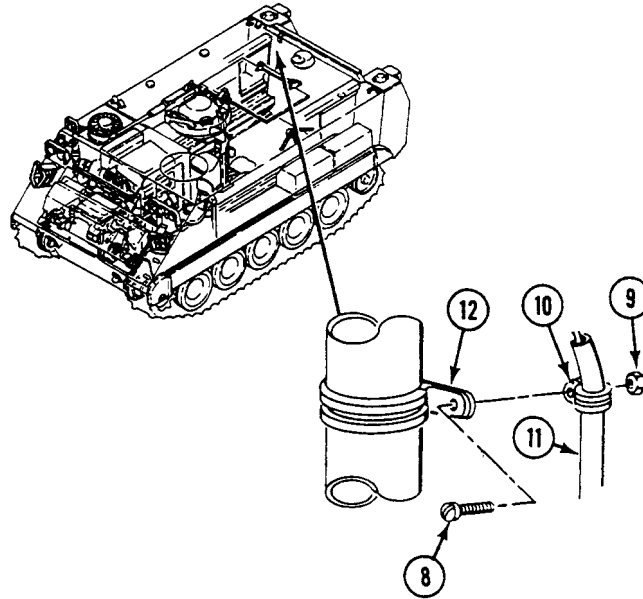

13. Disconnect circuit 451 lead (13) from rear bilge pump (14).
14. Disconnect circuit 21 (15), 22 (16), 23 (17), and 24 leads (18) from trailer harness.
15. Remove two screws (19), clamps (20), washers (21), harness (22), and circuit 90 lead (23) from two weldnuts.

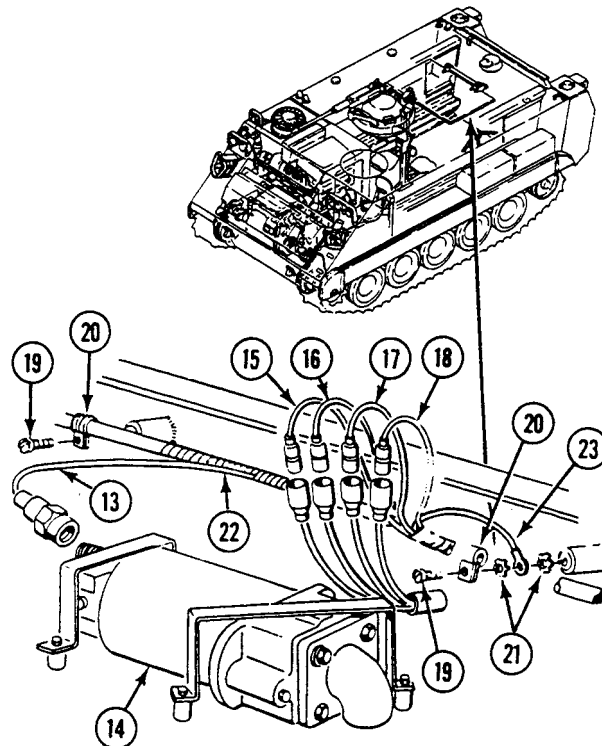

■ REPLACE REAR MAIN WIRING HARNESS (M113A3, M1059A3, AND M58) — Continued

0362 00

16. Remove screw (1), lockwasher (2), and clamp (3) that secure bilge pump tube clamp (4) and wiring harness (5) on weldnut. Discard lockwasher.

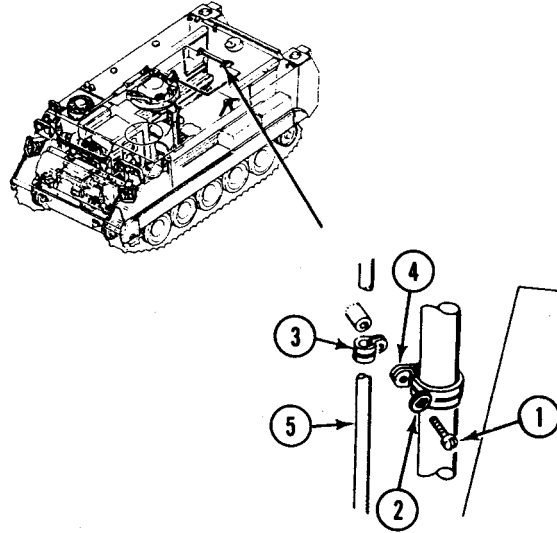

17. Remove two screws (6), nuts (7), and clamp (8) from floor transverse beam (9).

NOTE

■ Only the M58 and M1059A3 have the lockwasher.

18. Remove screw (10), nut (11), and clamp (8) from circuit 451 lead (12).
19. Remove three screws (13), lockwashers (14), clamps (15), and circuit 451 lead (12) from weldnut. Discard lockwashers.

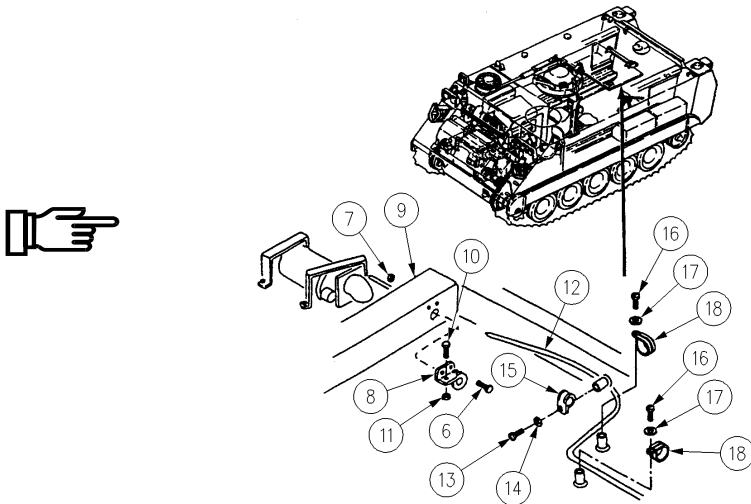

REPLACE REAR MAIN WIRING HARNESS (M113A3, M1059A3, AND M58) — Continued

0362 00 ■

20. If personnel heater is installed, disconnect circuit 402 lead (18) from personnel heater fuel pump (19).
21. If engine coolant heater is installed, disconnect circuit 402A lead (20) from engine coolant heater fuel pump (21).

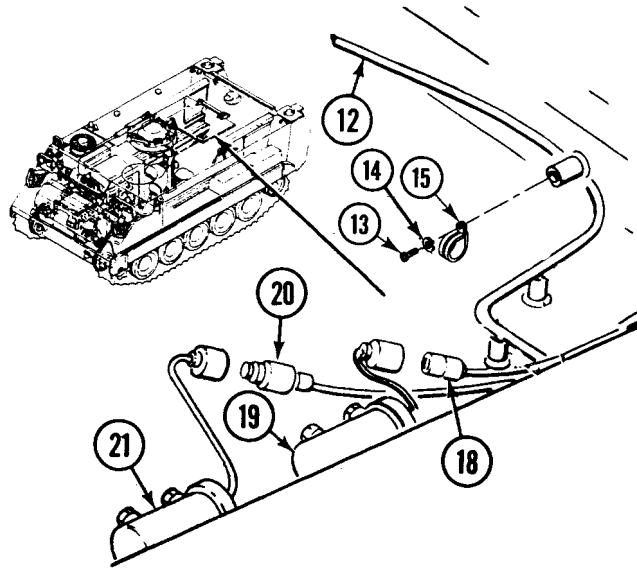

REPLACE REAR MAIN WIRING HARNESS (M113A3, M1059A3, AND M58) — Continued

0362 00

22. Remove strap (1) from harness (2). Discard strap.
23. Remove two screws (3), washers (4), and clamps (19) from harness (2).
24. Remove two screws (5), washers (6), and harness guard (7) from rear hull.
25. Remove two screws (8), washers (9), nuts (10), and clamps (11) that secure harness (2) and guard (7) to rear hull. Remove harness from guard.

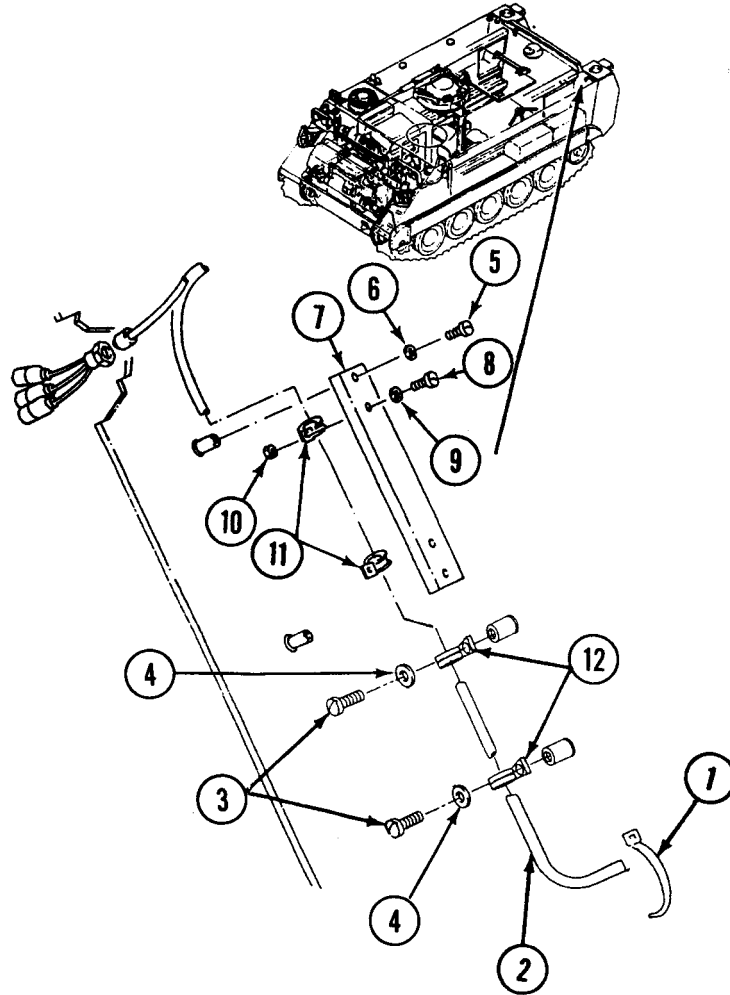

REPLACE REAR MAIN WIRING HARNESS (M113A3, M1059A3, AND M58) — Continued

0362 00 ■

26. Disconnect circuit 21 (12), 22 (13), and 24 (14) leads from left tail light (15).

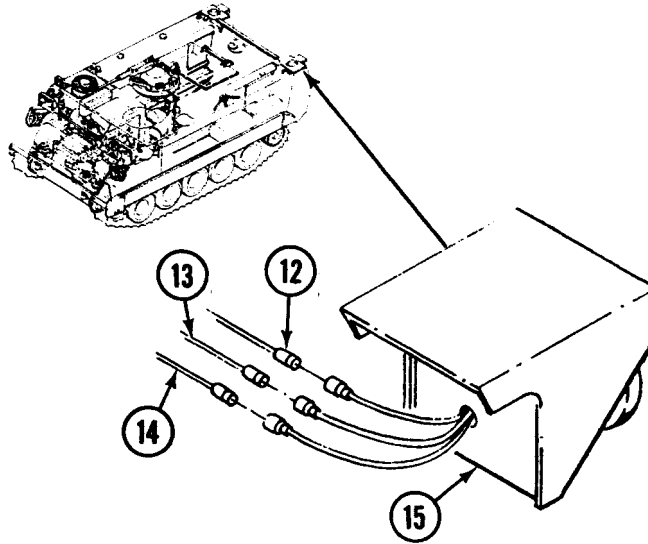

27. Disconnect circuit 30 lead (16) from fuel transmitter (17) on left fuel tank (18).

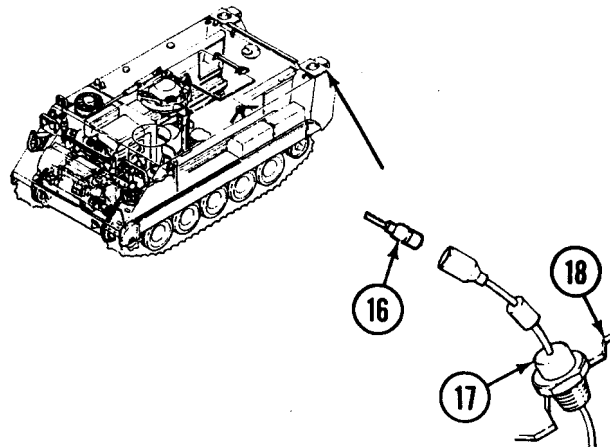

REPLACE REAR MAIN WIRING HARNESS (M113A3, M1059A3, AND M58) — Continued

0362 00

NOTE

Step 28 and Step 29 are for the M113A3 and M1059A3 only. For M58 only, see Replace Antenna Support (WP 0602 00).

28. Remove two screws (1), lockwashers (2), and washers (3) that secure harness guard (4) to top of fuel tank (5). Remove guard. Discard lockwashers.
29. Remove two screws (6), lockwashers (7), and washers (8) that secure harness bracket (9) to top of fuel tank (5). Remove guard. Discard lockwashers.

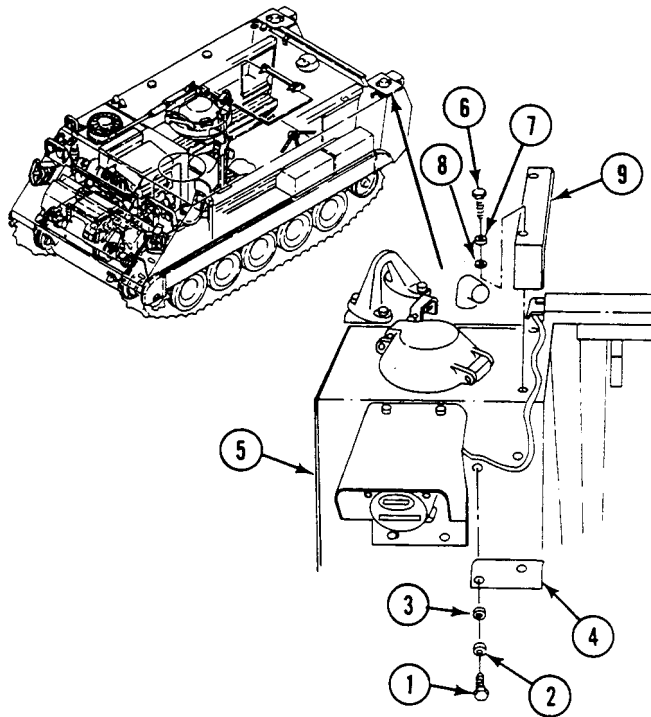

REPLACE REAR MAIN WIRING HARNESS (M113A3, M1059A3, AND M58) — Continued

0362 00 ■

30. Remove screw (10), lockwasher (11), and washer (12), that secure harness guard (13) on top of rear hull. Remove guard. Discard lockwasher.

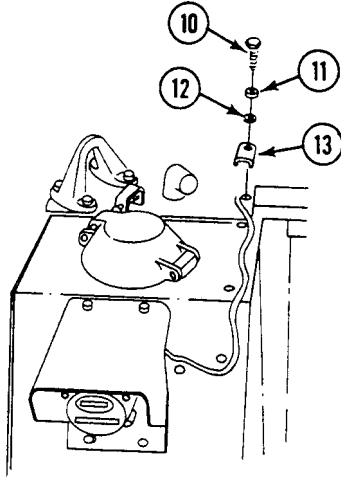

31. Remove four screws (3), lockwashers (4), washers (2), and harness access cover (1) from top of rear hull. Discard lockwashers (M58 only).

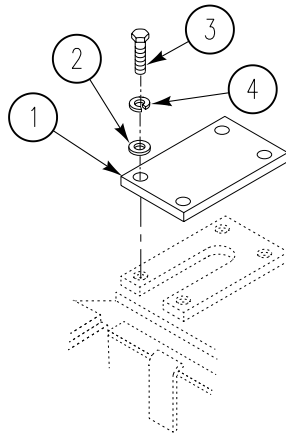

REPLACE REAR MAIN WIRING HARNESS (M113A3, M1059A3, AND M58) — Continued

0362 00

NOTE

The M58 does not use connector, bushing, and hardware only adhesive sealant on wiring harness in hull opening. To remove leads on M58, carefully cut adhesive sealant and pull harness into carrier.

32. Loosen nut (14) that secures circuit 21 (15), 22 (16), 24 (17), and 30 (18) leads with rubber bushing (19) in connector (20). Separate nut (14), washer (21), and rubber bushing (19) from connector.
33. Remove connector (20) and harness from top of hull. Pull harness into carrier.

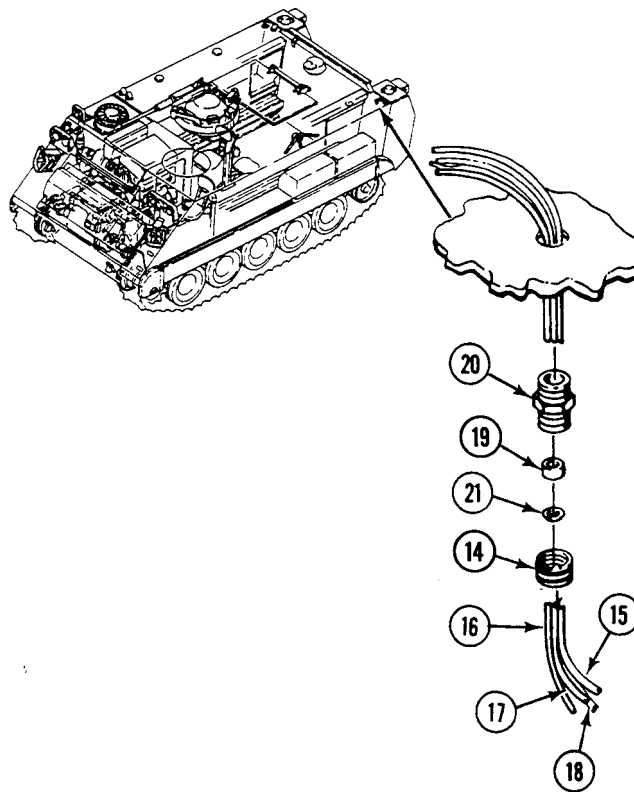

34. Remove 12 screws (1), washers (2), clamps (3), and harness (4) from left side plate of hull.

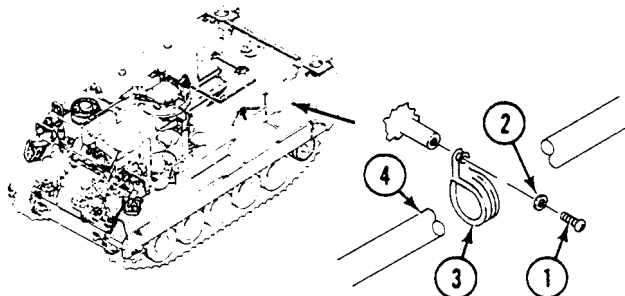

REPLACE REAR MAIN WIRING HARNESS (M113A3, M1059A3, AND M58) — Continued

0362 00 ■

35. Disconnect circuit 38 lead (5) from left dome light (6).
36. If personnel heater is installed, disconnect circuit 402 lead (7) from personnel heater wiring harness.
37. If engine coolant heater is installed, disconnect circuit 402A lead (8) from coolant heater wiring harness.
38. If personnel and coolant heater are installed, disconnect circuit 400 lead (9) from personnel heater control box and circuit 400A lead (10) from coolant heater control box.

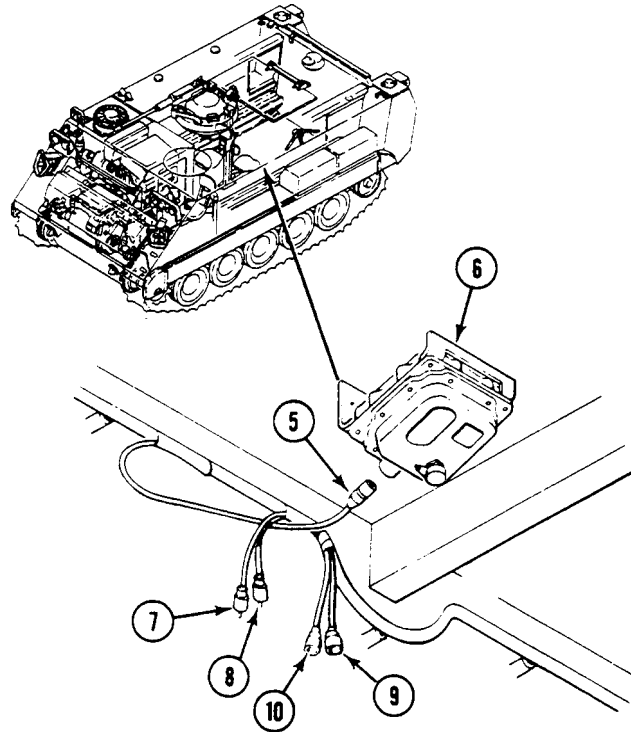

39. Remove three screws (11), washers (12), clamps (13), and harness (14) from left front side plate of hull.

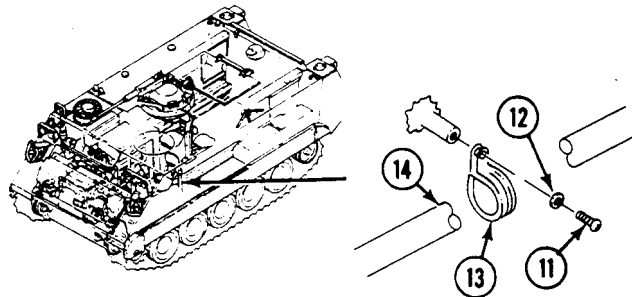

REPLACE REAR MAIN WIRING HARNESS (M113A3, M1059A3, AND M58) — Continued

0362 00

40. Remove eight screws (1), washers (2), locknuts (3), and master switch panel (4) from distribution box (5). Discard locknuts.

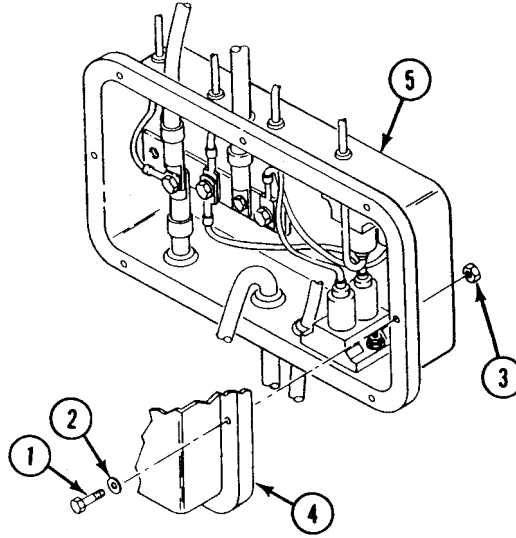

REPLACE REAR MAIN WIRING HARNESS (M113A3, M1059A3, AND M58) — Continued

0362 00 ■

41. Remove locknut (6), circuit 2 (7), 400 (8), and 6 (9) leads from conductor bus (10) of master switch panel (4). Remove circuit 400 lead (8) with grommet (11) from distribution box (5). Discard locknut.
42. Remove nut (12), lockwasher (13), and circuit 2A lead (14) from conductor bus (10). Discard lockwasher.

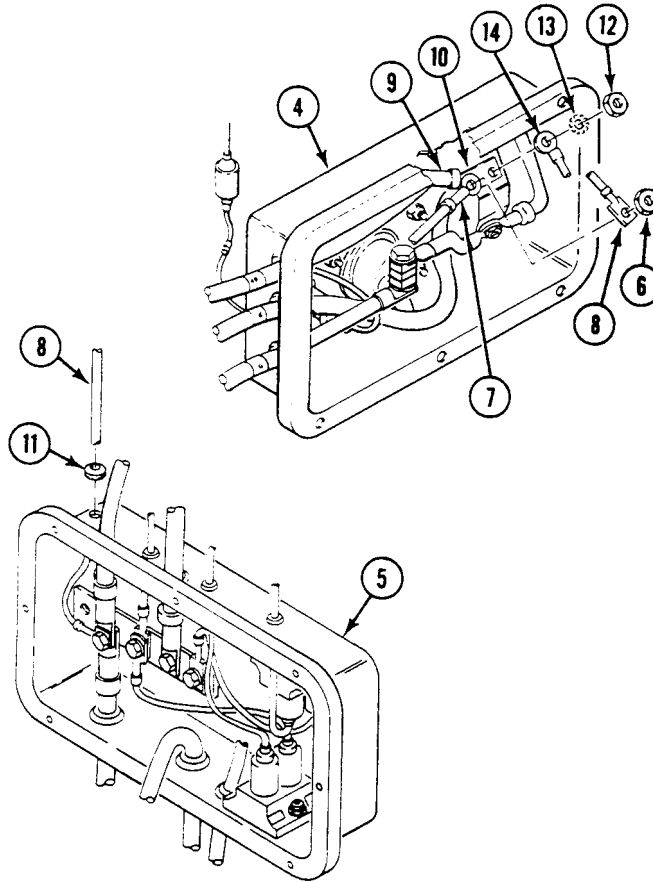

■ REPLACE REAR MAIN WIRING HARNESS (M113A3, M1059A3, AND M58) — Continued

0362 00

43. Disconnect circuit 37 lead (15) from circuit 37 lead (16) of utility outlet (17) on master switch panel (4).

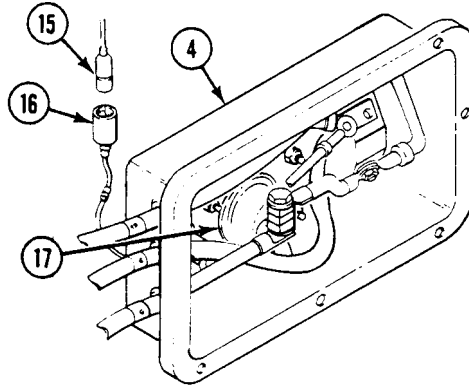

44. Disconnect circuit 450 lead (1) from bilge pump circuit breaker (2) in distribution box (3). Remove circuit 450 lead with grommet (4) from distribution box.
45. Disconnect circuit 450B lead (5) from bilge pump circuit breaker (6) in distribution box (3). Remove circuit 450B with grommet (7) from distribution box.

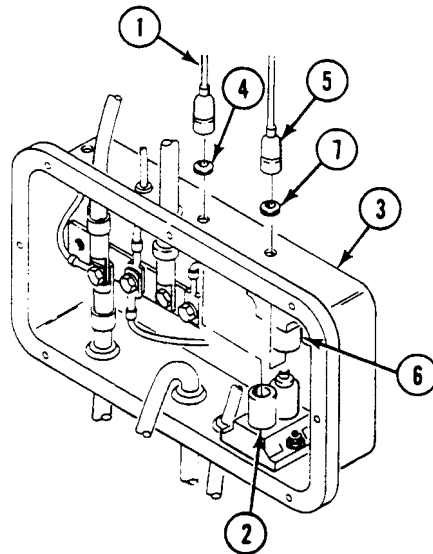

REPLACE REAR MAIN WIRING HARNESS (M113A3, M1059A3, AND M58) — Continued

0362 00 ■

46. Remove two nuts (8), mounts (9), flat washers (10), and screws (11) that secure instrument panel (12) to two struts (13).
47. Support panel. Remove two screws (14), washers (15), one lockwasher (16), and ground lead (17) from two mounts (18) and upper support (19). Discard lockwasher.
48. Support panel (12) on two struts (13) to gain access to rear of panel.

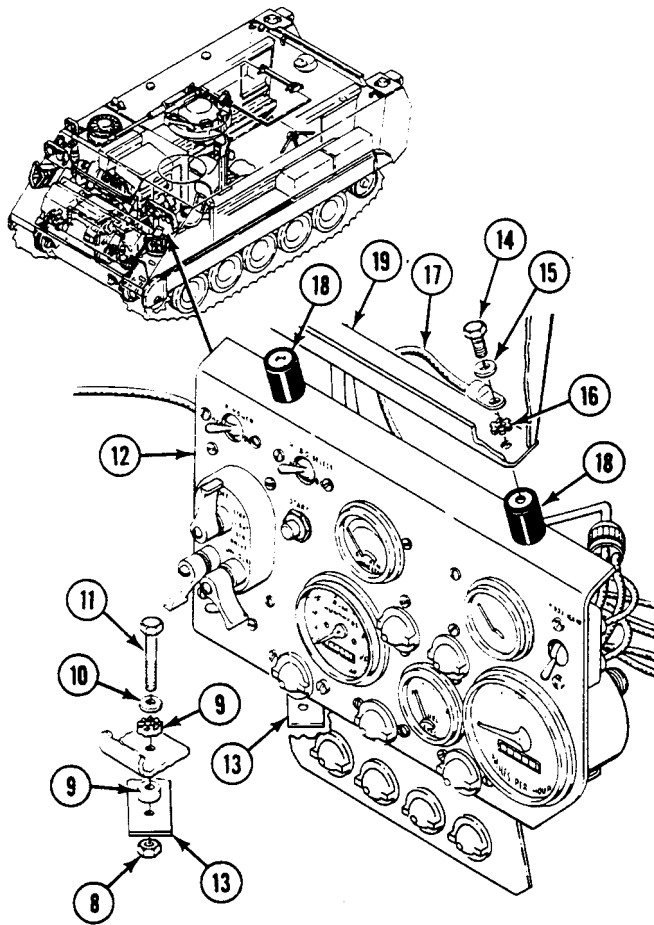

REPLACE REAR MAIN WIRING HARNESS (M113A3, M1059A3, AND M58) — Continued

0362 00

49. Disconnect circuit 30 (20) and 31 (21) leads from fuel level gage switch (22).

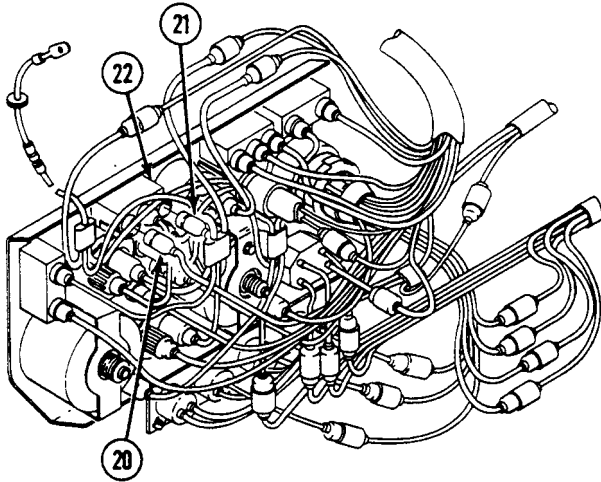

50. Disconnect circuit 451B lead (1) from rear bilge pump on indicator light (2).
51. Disconnect circuit 450 (3), 450B (4), and 451A (5) leads from bilge pump switch (6).
52. Disconnect circuit 38 lead (7) from special purpose cable assembly (8).
53. Disconnect circuit 21 (9), 22 (10), 23 (11), and 24 (12) leads from front main wiring harness (13).
54. Remove rear main wiring harness (14) from carrier.

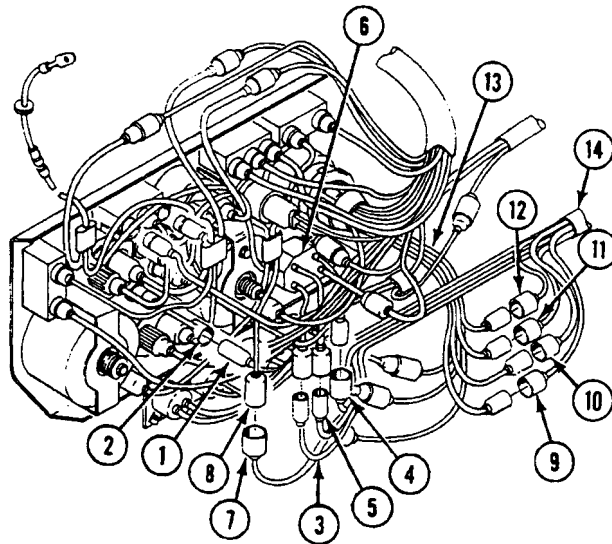

REPLACE REAR MAIN WIRING HARNESS (M113A3, M1059A3, AND M58) — Continued

0362 00 ■

TEST AND INSPECTION**INSPECT AND REPAIR**

1. Inspect wiring harness for damaged connectors and terminals. Repair as needed (WP 0382 00).

INSTALLATION

1. Connect circuit 21 (15), 22 (16), 23 (17), and 24 (18) leads to front main wiring harness (19).
2. Connect circuit 38 lead (20) to special purpose cable assembly (21).
3. Connect circuit 450 (22), 450B (23), and 451A (24) leads to bilge pump switch (25).
4. Connect circuit 451B lead (26) to rear bilge pump on indicator light (27).
5. Connect circuit 30 (28) and 31 (29) leads to fuel level gage switch (30).

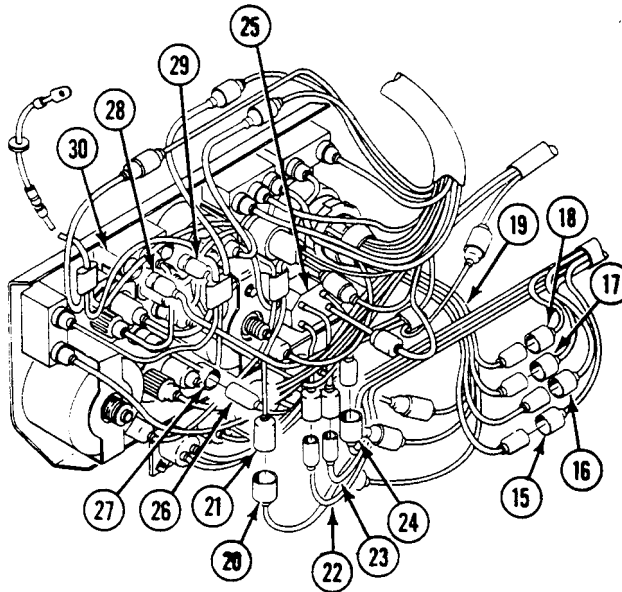

■ REPLACE REAR MAIN WIRING HARNESS (M113A3, M1059A3, AND M58) — Continued

0362 00

6. Support instrument panel (1) on two struts (2).
7. Install ground lead (3) and new lockwasher (4) on upper support (5). Install panel (1) with two mounts (6) on support (5). Secure with two screws (7) and washers (8).
8. Install panel (1) on two struts (2). Secure with two nuts (9), mounts (10), flat washers (11), and screws (12).

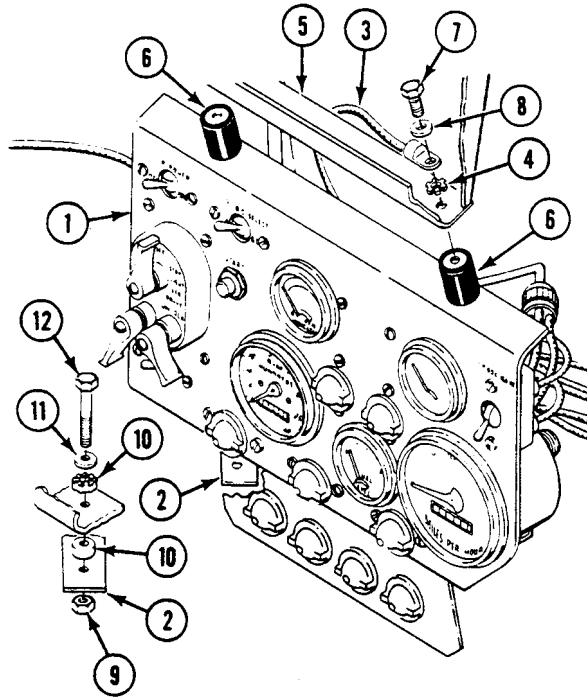

REPLACE REAR MAIN WIRING HARNESS (M113A3, M1059A3, AND M58) — Continued

0362 00 ■

9. Install new grommet (13) and circuit 450B lead (14) in distribution box (15). Connect 450B lead to rear bilge pump circuit breaker (16).
10. Install new grommet (17) and circuit 450 lead (18) in distribution box (15). Connect 450 lead to front bilge pump circuit breaker (19).

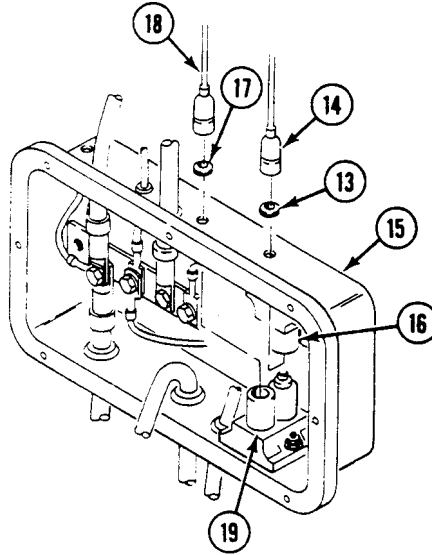

11. Connect circuit 37 lead (20) to circuit 37 lead (21) of utility outlet (22) on master switch panel (23).

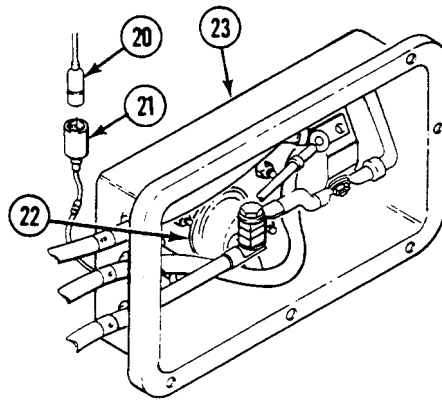

REPLACE REAR MAIN WIRING HARNESS (M113A3, M1059A3, AND M58) — Continued

0362 00

12. Install new grommet (1) on circuit 400 lead (2). Route lead into distribution box (3).

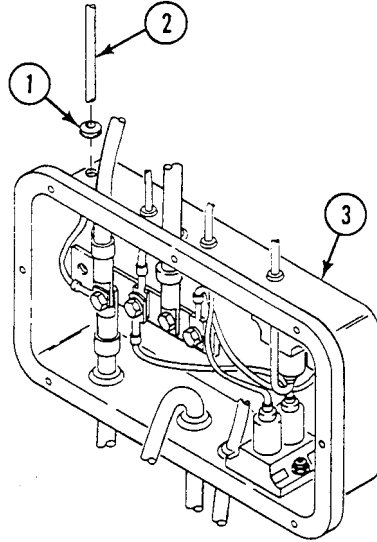

13. Install circuit 6 (4), 2 (5), and 400 (6) leads on conductor bus (7) of master switch panel (8). Secure with new locknut (9).
14. Install circuit 2A lead (10) on conductor bus (7) of master switch panel (8). Secure with new lockwasher (11) and nut (12).

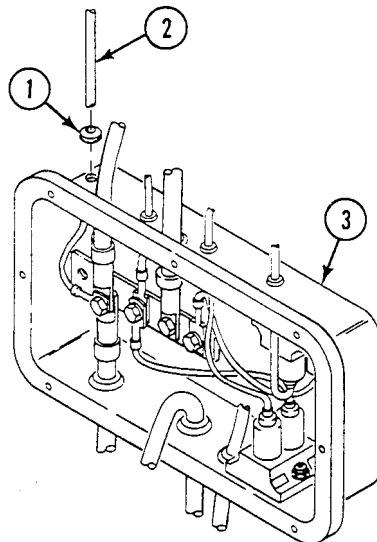

REPLACE REAR MAIN WIRING HARNESS (M113A3, M1059A3, AND M58) — Continued

0362 00 ■

15. Install master switch panel (8) on distribution box (3). Secure with eight screws (13), washers (14), and new locknuts (15).

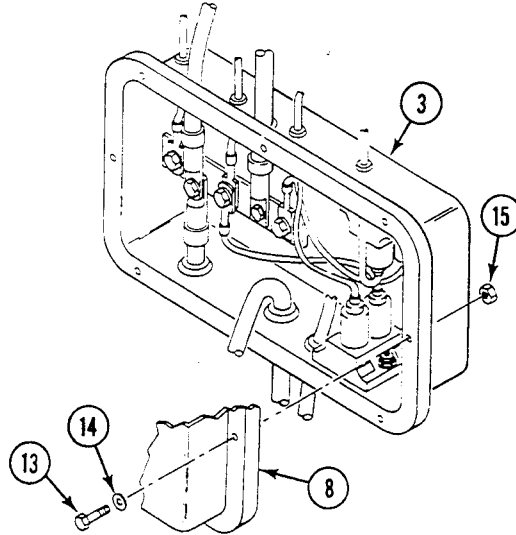

16. Install harness (16) on left front side plate of hull, near instrument panel. Secure with three clamps (17), screws (18), and washers (19).

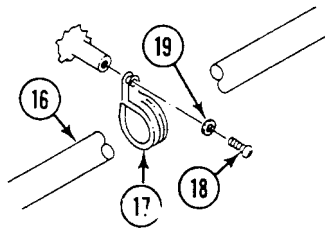

■ REPLACE REAR MAIN WIRING HARNESS (M113A3, M1059A3, AND M58) — Continued

0362 00

17. If personnel heater is installed, connect circuit 400 lead (1) to personnel heater control box.
18. If engine coolant heater is installed, connect circuit 400A lead (2) to coolant heater control box.
19. If engine coolant heater is installed, connect circuit 402A lead (3) to coolant heater wiring harness.
20. If personnel heater is installed, connect circuit 402 lead (4) to personnel heater wiring harness.
21. Connect circuit 38 lead (5) to left dome light (6).

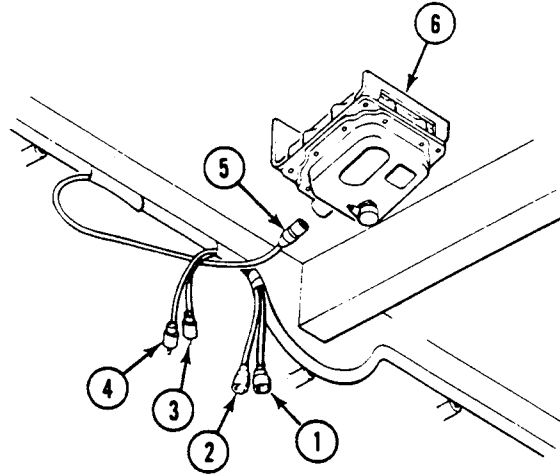

22. Install harness (7) along left side plate of hull. Secure harness on weld nuts (8) with 12 clamps (9), screws (10), and washers (11).

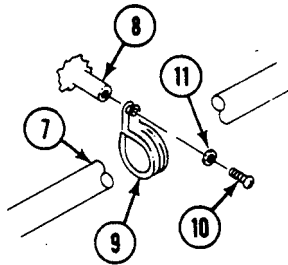

REPLACE REAR MAIN WIRING HARNESS (M113A3, M1059A3, AND M58) — Continued

0362 00 ■

NOTE

The M58 does not use connector on wiring harness in hull opening. On M58, route leads through opening in hull. Apply adhesive sealant around harness, filling opening to a depth of 0.5 to 1.5 inches (1.27 to 3.81 cm).

23. Route circuit 21 (12), 22 (13), 24 (14), and 30 (15) leads through connector (16) and out of carrier. Install connector on rear top of hull. (All except M58.)

NOTE

The M58 does not use connector, bushing, and hardware only adhesive sealant on wiring harness in hull opening.

24. Install rubber bushing (17) into connector (16). Secure bushing and leads in connector with nut (18) and washer (19). (All except M58.)

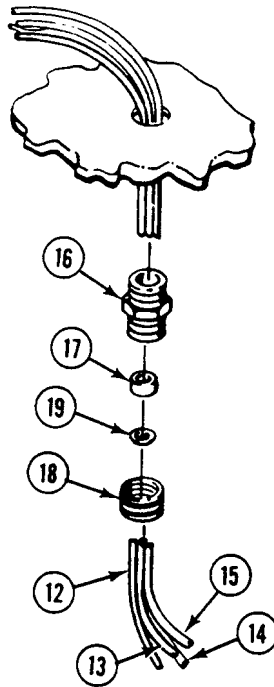

REPLACE REAR MAIN WIRING HARNESS (M113A3, M1059A3, AND M58) — Continued

0362 00

NOTE**Steps 25 - 26 apply to M58 only.**

25. Install harness guard (1) on top of rear hull. Secure with screw (2), washer (3), and new lockwasher (4).
- Apply adhesive-sealant to harness access cover (1).
 - Install harness access cover (1), four new lockwashers (4), washers (3), and screws (2) on top of rear hull. (M58 only.)

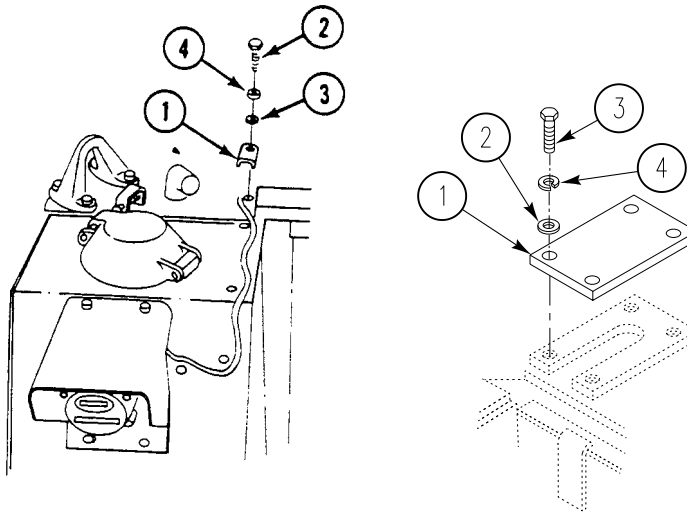

26. Connect circuit 30 lead (5) to transmitter (6) on left fuel tank (7).

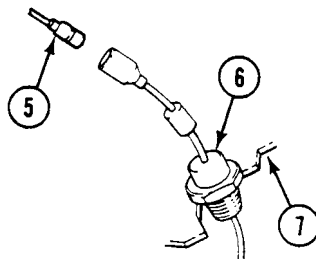

REPLACE REAR MAIN WIRING HARNESS (M113A3, M1059A3, AND M58) — Continued

0362 00 ■

27. Install harness bracket (8) on top of left fuel tank (7). Secure with two screws (9), washers (10), and new lockwashers (11).
28. Install harness guard (12) on top of left fuel tank (7). Secure with two screws (13), washers (14), and new lockwashers (15).

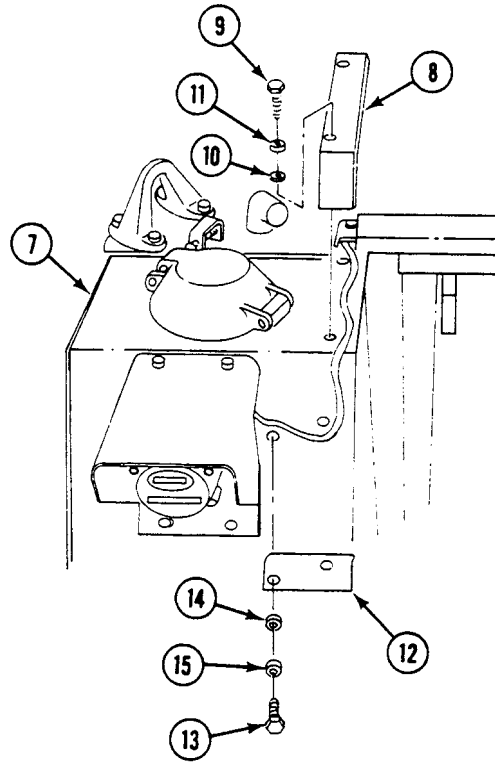

29. Connect circuit 21 (16), 22 (17), and 24 (18) leads to left tail light (19).

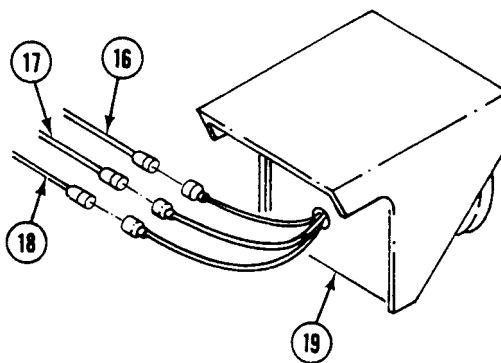

REPLACE REAR MAIN WIRING HARNESS (M113A3, M1059A3, AND M58) — Continued

0362 00

30. Install harness (1) on guard (2). Secure with two clamps (3), screws (4), washers (5), and nuts (6).
31. Install harness (1) and guard (2) on rear hull. Secure with two screws (7) and washers (8).
32. Install two clamps (9) on harness (1). Secure to hull weldnuts with two screws (10) and washers (12).
33. Install new strap (11) on harness (1).

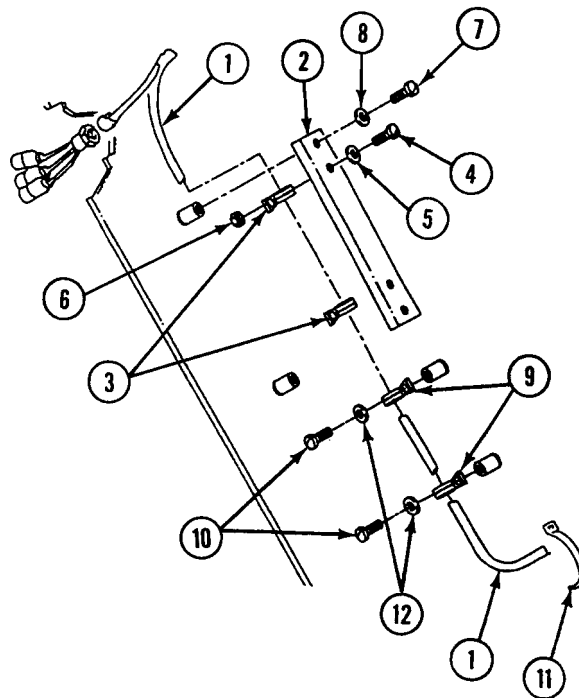

REPLACE REAR MAIN WIRING HARNESS (M113A3, M1059A3, AND M58) — Continued

0362 00 ■

34. If engine coolant heater is installed, connect circuit 402A lead (1) to engine coolant heater fuel pump (2).
35. If personnel heater is installed, connect circuit 402 lead (3) to personnel heater fuel pump (4).

NOTE

The lockwashers are used only on M58 and M1059A3.

36. Install circuit 451 lead (5). Secure with two clamps (10), screws (8), and new lockwashers (9). (M58 only).

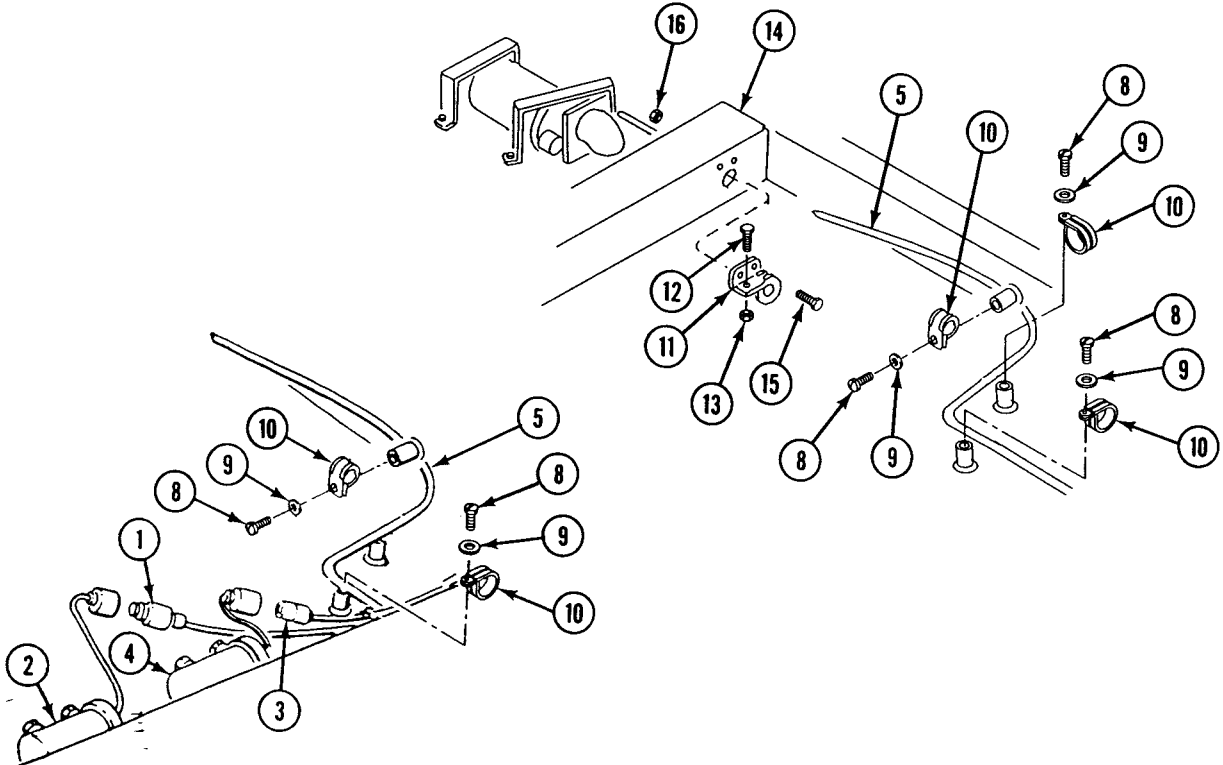

■ REPLACE REAR MAIN WIRING HARNESS (M113A3, M1059A3, AND M58) — Continued

0362 00

37. Install circuit 451 lead (5) on weldnut. Secure with three screws (8), new lockwashers (9), and clamps (10).
38. Install clamp (11) on circuit 451 lead (5). Secure with screw (12) and nut (13).
39. Install clamp (11) on floor transverse beam (14). Secure with two screws (15) and nuts (16).

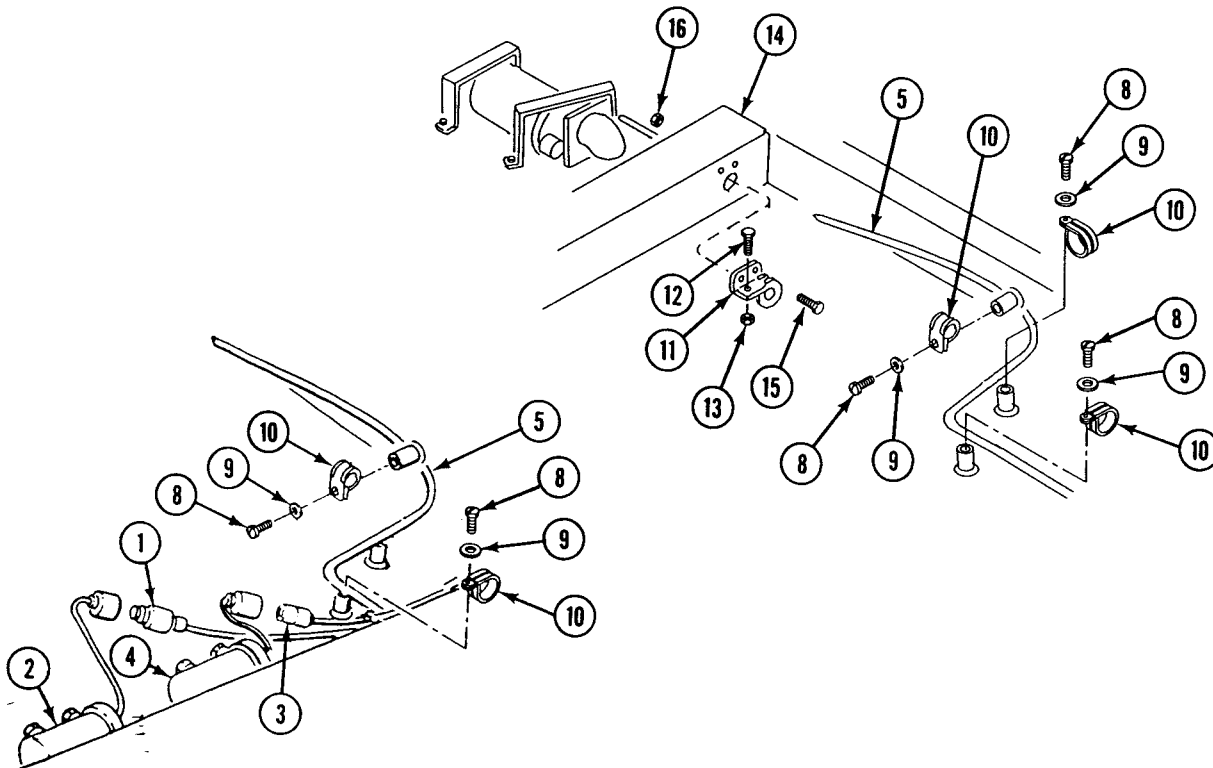

40. Install wiring harness (1) and bilge tube clamp (2) on weldnut (3). Secure with screw (4) and clamp (5) and new lockwasher (6).

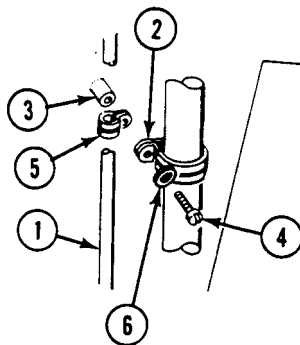

REPLACE REAR MAIN WIRING HARNESS (M113A3, M1059A3, AND M58) — Continued

0362 00 ■

41. Install harness (7) and bilge pump ground lead (8) on weld nuts (9). Secure with two clamps (10), screws (11), and washers (12).
42. Connect circuit 21 (13), 22 (14), 23 (15), and 24 (16) leads to trailer harness (17).
43. Connect circuit 451 lead (18) to rear bilge pump (19).

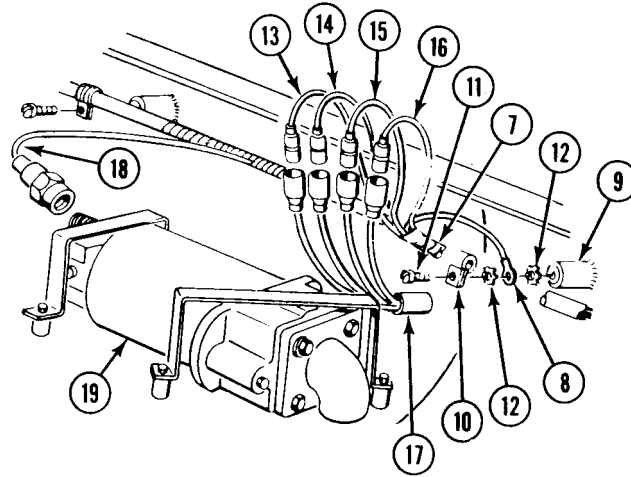

44. Install harness (20) on bilge pump tube (21). Secure with clamp (22), screw (23), and nut (24).

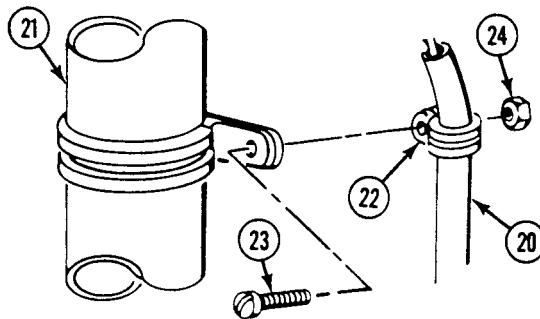

REPLACE REAR MAIN WIRING HARNESS (M113A3, M1059A3, AND M58) — Continued

0362 00

NOTE

The M58 does not use connector, bushing, and hardware only adhesive sealant on wiring harness in hull opening.

45. Route circuit 23 (25), 24 (26), and 31 (27) leads through connector (28) out of hull. Install connector on top of hull (from inside hull). (All except M58.)

NOTE

The M58 does not use connector on wiring harness in hull opening. On M58, route leads through opening in hull. Apply adhesive sealant around harness, filling opening to a depth of 0.5 to 1.5 inches (1.27 to 3.81 cm).

46. Install rubber bushing (29) with leads (25), (26), (27) into connector (28). Secure rubber bushing in connector with nut (30) and washer (31). (All except M58.)

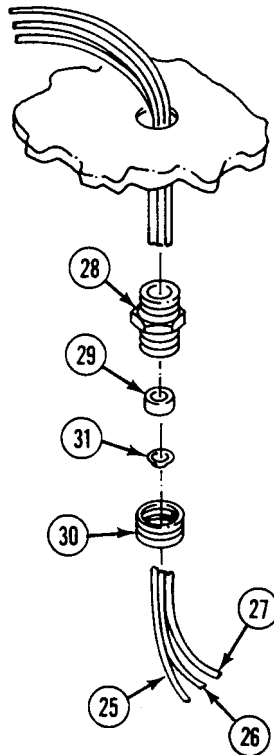

REPLACE REAR MAIN WIRING HARNESS (M113A3, M1059A3, AND M58) — Continued

0362 00 ■

47. Install harness guard (1) on top of rear hull. Secure with screw (2), new lockwasher (3), and washer (4)
48. Install harness access cover (1) on top of rear hull. (M58 only.)
 - a. Apply adhesive-sealant to harness access cover (1).
 - b. Install harness access cover (1), four new lockwashers (4), washers (3), and screws (2) on top of rear hull.

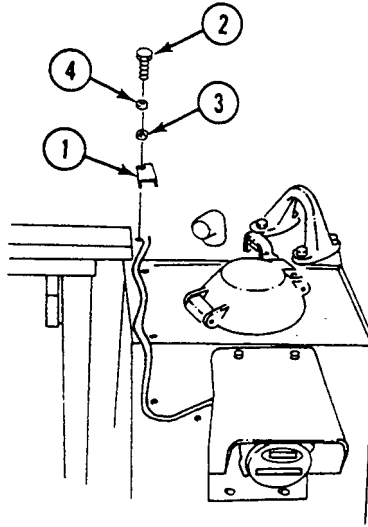

REPLACE REAR MAIN WIRING HARNESS (M113A3, M1059A3, AND M58) — Continued

0362 00

NOTE

Step 49 and Step 50 are for M113A3 and M1059A3 only. For M58 only, see Replace Antenna Support (WP 0602 00).

- 49. Install harness bracket (5) on top of right fuel tank (6). Secure with two screws (7), new lockwashers (8), and washers (9).
- 50. Install harness guard (10) on top of right fuel tank (6). Secure with two screws (11), new lockwashers (12), and washers (13).

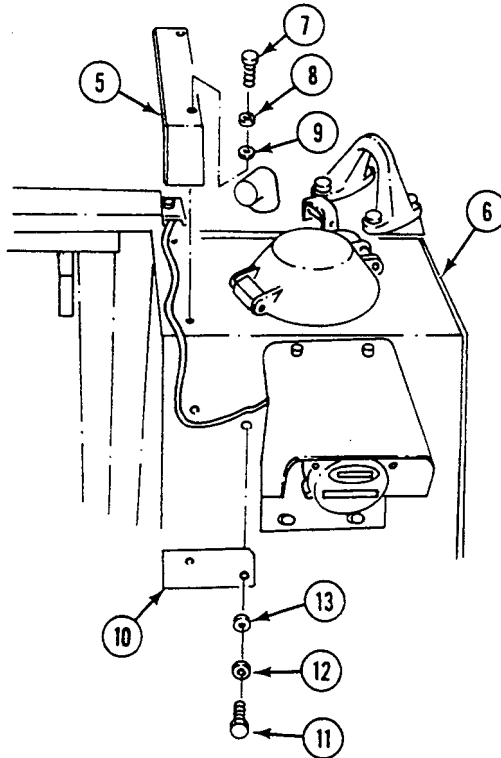

- 51. Connect circuit 31 lead (14) to right fuel transmitter (15) on fuel tank (6).

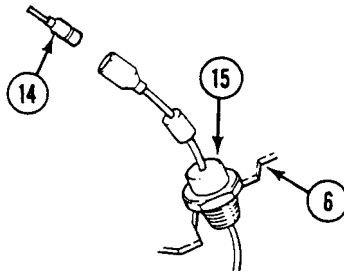

REPLACE REAR MAIN WIRING HARNESS (M113A3, M1059A3, AND M58) — Continued

0362 00 ■

52. Connect circuit 23 (16) and 24 (17) leads to right tail light (18).

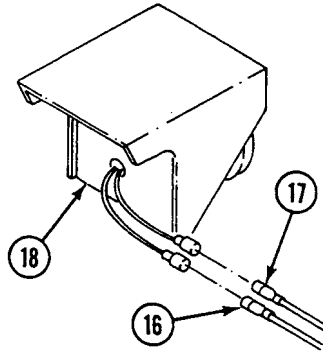

NOTE

Step 53 and Step 54 are for M113A3 and M1059A3 only. For M58 only, see Replace Antenna Support (WP 0602 00).

53. Install two screws (1) new lockwashers (2), washers (3), and harness guard (4) to top of fuel tank (5).
 54. Install two screws (6), new lockwashers (7), washers (8), and harness bracket (9) to top of fuel tank (5).

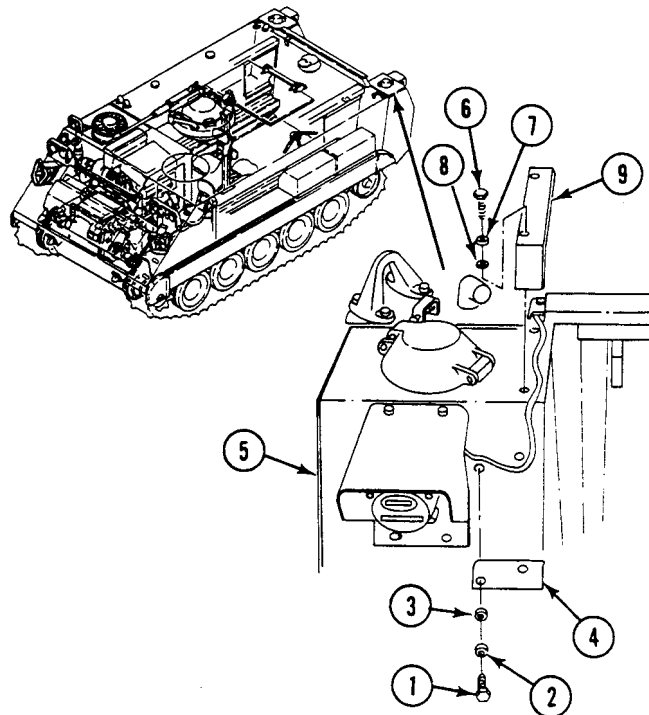

REPLACE REAR MAIN WIRING HARNESS (M113A3, M1059A3, AND M58) — Continued

0362 00

NOTE

M58 vehicle has a smoke system operator dome light on left side of carrier.

- 55. Install circuit 38 lead (10) on weldnuts. Secure with three clamps (11) and screws (12). (M113A3 and M1059A3 only.)
- 56. Install circuit 38 lead (10) on right dome light bracket (13). Secure with clamp (14), screw (15), and nut (16). (Left dome light M58 only.)
- 57. Connect circuit 38 lead (10) to rear dome light (17). (Left dome light M58 only.)

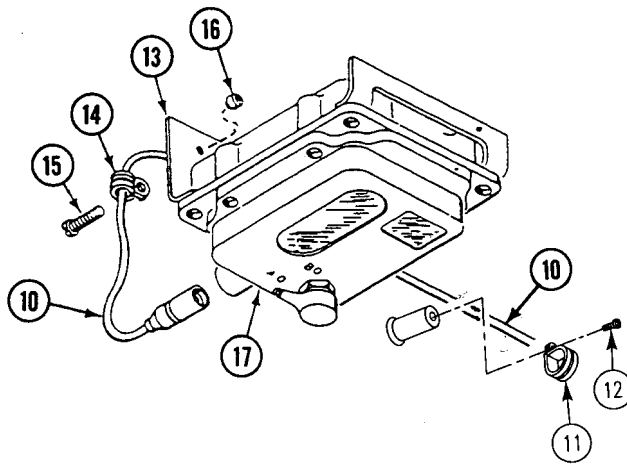
**FOLLOW-THROUGH STEPS**

- 1. Install smoke generator fog oil tank module (M1059A3 only) (WP 0753 00).
- 2. Install rear floor plate (see Table of Contents).
- 3. Connect battery ground strap (WP 0337 00).
- 4. Start engine (see your -10).
- 5. Check that electrical system works right (see your -10).
- 6. Raise and lock ramp (see your -10).
- 7. Stop engine (see your -10).

END OF TASK

REPLACE REAR MAIN WIRING HARNESS (M577A3 ONLY)

0363 00

THIS WORK PACKAGE COVERS:

- Removal (page 0363 00-2).
- Inspection and Repair (page 0363 00-15).
- Installation (page 0363 00-15).

INITIAL SETUP:

Maintenance Level

Unit

Tools and Special Tools

General Mechanic's Tool Kit (WP 0926 00, Item 65)

Materials/Parts

- Nonelectrical wire (WP 0928 00, Item 42)
- Gasket
- Grommet (10)
- Locknut (8)
- Lockwasher (59)

Personnel Required

Unit Mechanic

References

- See your -10
- TM 11-7010-256-12&P

Equipment Condition

- Engine stopped (see your -10)
 - Carrier blocked (see your -10)
 - Ramp lowered (see your -10)
 - Battery access cover removed (see your -10)
 - Battery ground lead disconnected (WP 0338 00)
 - Rear floor plate removed (WP 0539 00)
-

REMOVAL

1. Disconnect circuit 29 lead (1) from right fuel quantity sending unit (2).
2. Remove lockwire (3), screw (4), lockwasher (5), and ground lead (6) from sending unit (2). Discard lockwire and lockwasher.
3. Remove three screws (7), two lockwashers (8), flat washer (9), ground lead (6), and three clamps (10), from three weldnuts (11). Remove clamps (10) from circuit 29 lead (1). Discard lockwashers.
4. Disconnect circuit 23 lead (12) and circuit 24 lead (13) from right tail light (14).
5. If NBC unit is installed, disconnect circuit 415 lead (15) from NBC unit switch.
6. Disconnect circuit 37A lead (16) from right utility outlet lead (17).
7. Remove three screws (1), six lockwashers (3), three clamps (25) and rear main wiring harness (2) from three weldnuts. Discard lockwashers.

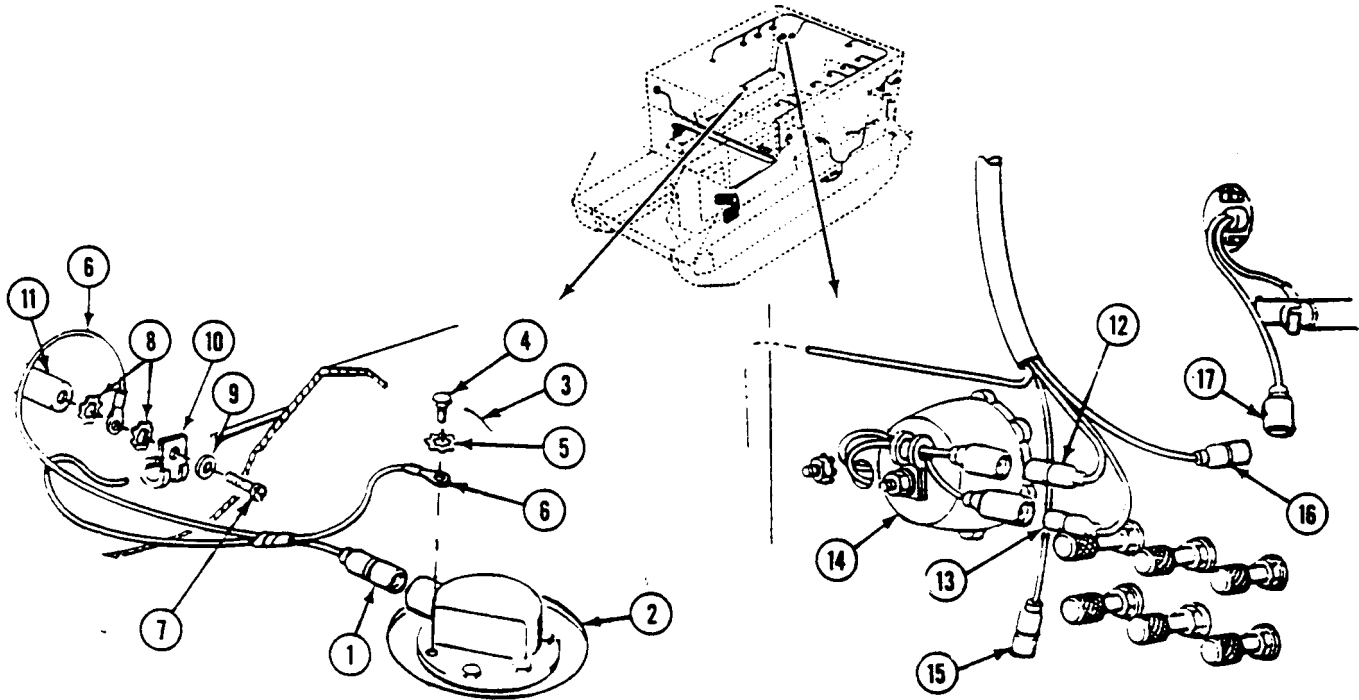

REPLACE REAR MAIN WIRING HARNESS (M577A3 ONLY) — Continued

0363 00

8. Disconnect four circuit 38C leads (4) from four right side dome lights (5).
9. Remove six screws (1), lockwashers (3), clamps (25) and rear main wiring harness (2) from six weldnuts. Discard lockwashers.

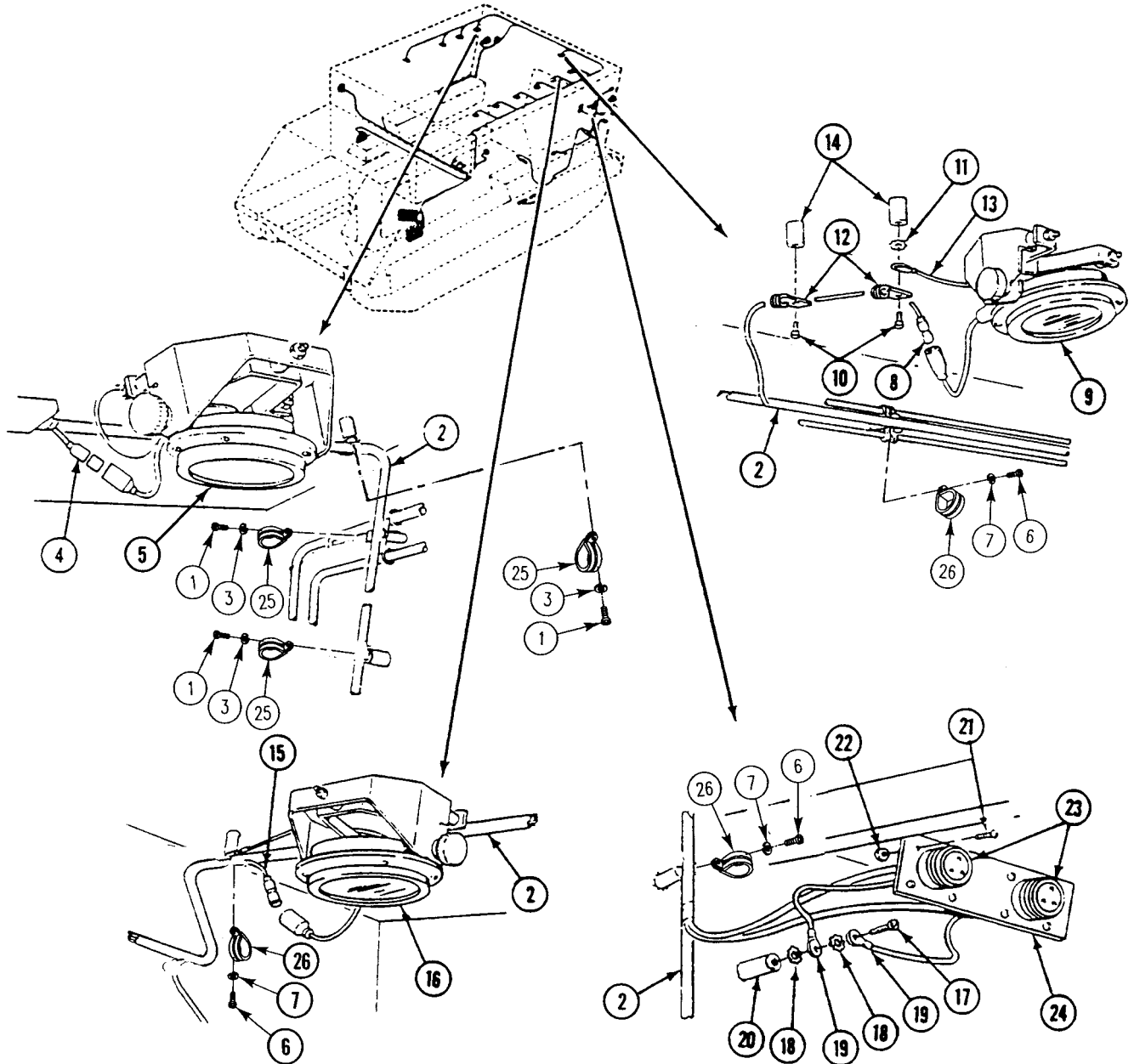

10. Disconnect circuit 38B lead (8) from rear blackout dome light (9).
11. Remove two screws (10), one lockwasher (11), two clamps (12), and ground lead (13) from two weldnuts (14). Remove clamps (12) from circuit 38B lead (8). Discard lockwasher.
12. Disconnect four circuit 38C leads (15) from four left side dome lights (16).
13. Remove screw (17), two lockwashers (18), and ground leads (19) from weldnut (20). Discard lockwashers.

REPLACE REAR MAIN WIRING HARNESS (M577A3 ONLY) — Continued

0363 00

14. Remove eight screws (21), nuts (22), and two circuit 48 connectors (23) from bracket (24).

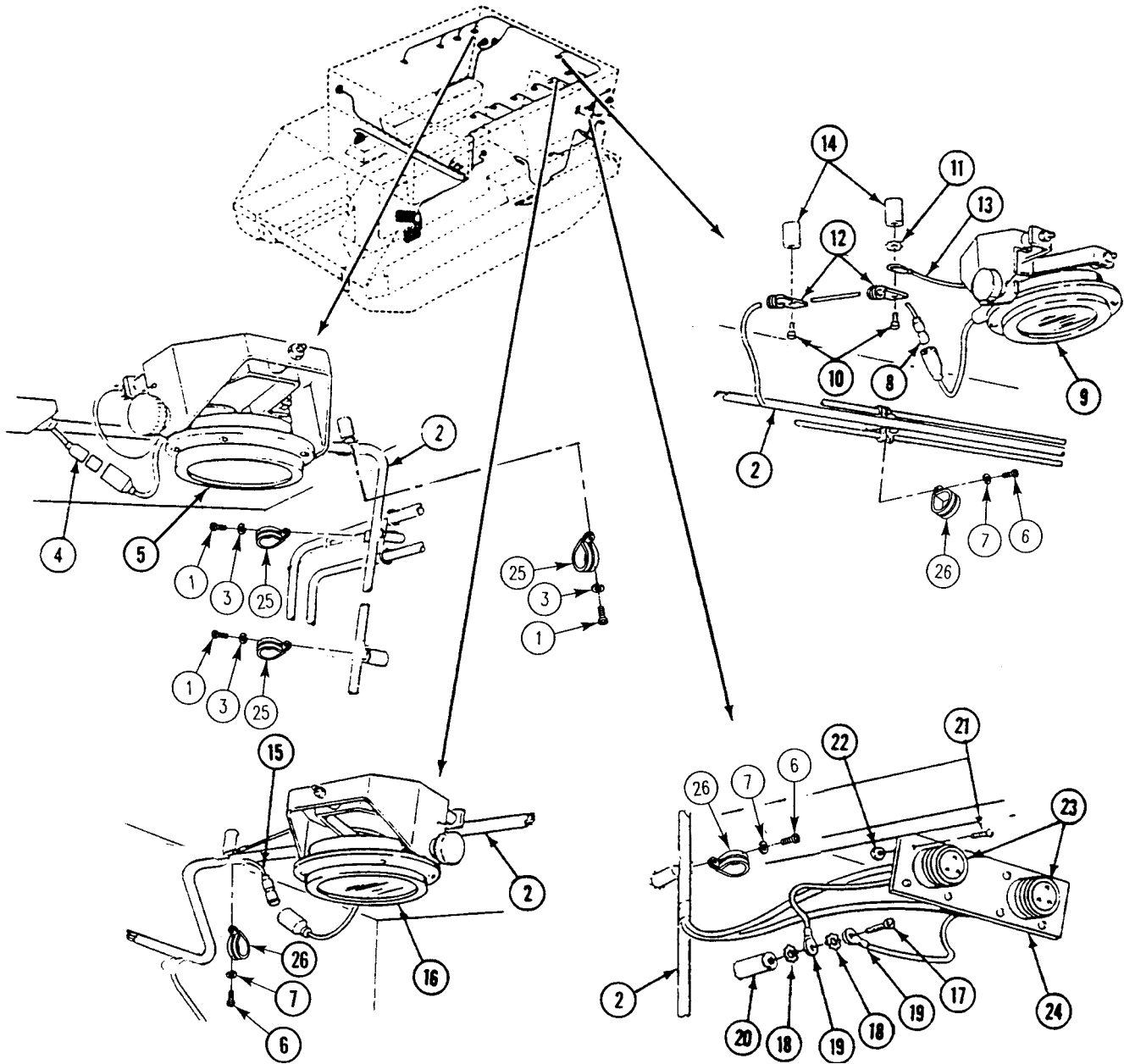

REPLACE REAR MAIN WIRING HARNESS (M577A3 ONLY) — Continued

0363 00

15. Disconnect circuit 37B lead (1) from left utility outlet lead (2).
16. Disconnect circuit 21 lead (3), circuit 22 lead (4), and circuit 24 lead (5) from left tail light leads (6).
17. Disconnect circuit 38 lead (7), circuit 38A lead (8), and circuit 38E lead (9) from dome light switch (10).
18. Disconnect circuit 38C lead (11) and circuit 38E lead (12) from blackout dome light switch (13).
19. Disconnect circuit 509 and 509A connector (14) from buzzer switch (15).
20. Remove seven screws (16), lockwashers (18), clamps (26), and rear main wiring harness (17) from seven weldnuts. Discard lockwashers.
21. Remove two screws (19), one lockwasher (20), and two clamps (21), from two weldnuts (22). Remove clamps (21) from circuit 30 lead (23) and circuit 509 lead (24). Discard lockwasher.
22. Disconnect circuit 509 lead (24) from buzzer (25).

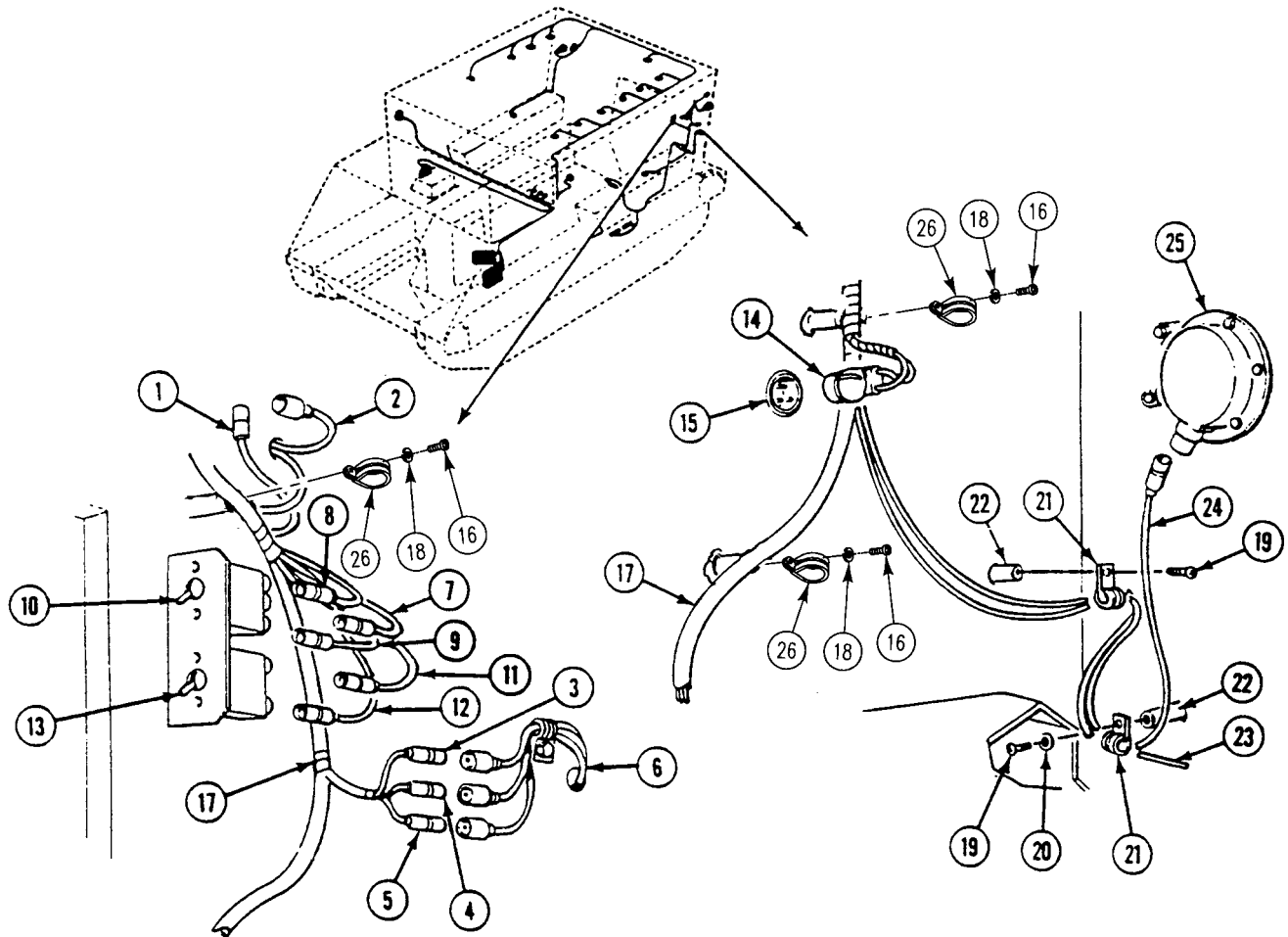

REPLACE REAR MAIN WIRING HARNESS (M577A3 ONLY) — Continued

0363 00

23. Disconnect circuit 30 lead (1) from left fuel quantity sending unit (2).
24. Remove lockwire (3), one screw (4), lockwasher (5), and ground lead (6) from sending unit (2). Discard lockwire and lockwasher.
25. Remove two screws (7), clamps (8), lockwashers (9), and ground lead (6) from two weldnuts (10). Remove clamps (8) from circuit 30 lead (1). Discard lockwashers.
26. Disconnect circuit 402 lead (11) from personnel heater fuel pump (12).
27. Remove screw (13), lockwasher (14), and clamp (15) from weldnut (16). Remove clamp (15) from rear main wiring harness (17). Discard lockwasher.
28. Remove two screws (18), nuts (19), clamp (20), and rear main wiring harness (17) from floor transverse beam (21).
29. Remove screw (22), nut (23), and clamp (20) from rear main wiring harness (17).
30. Remove three screws (24), lockwashers (25), clamps (26), and rear main wiring harness (17) from three weldnuts.

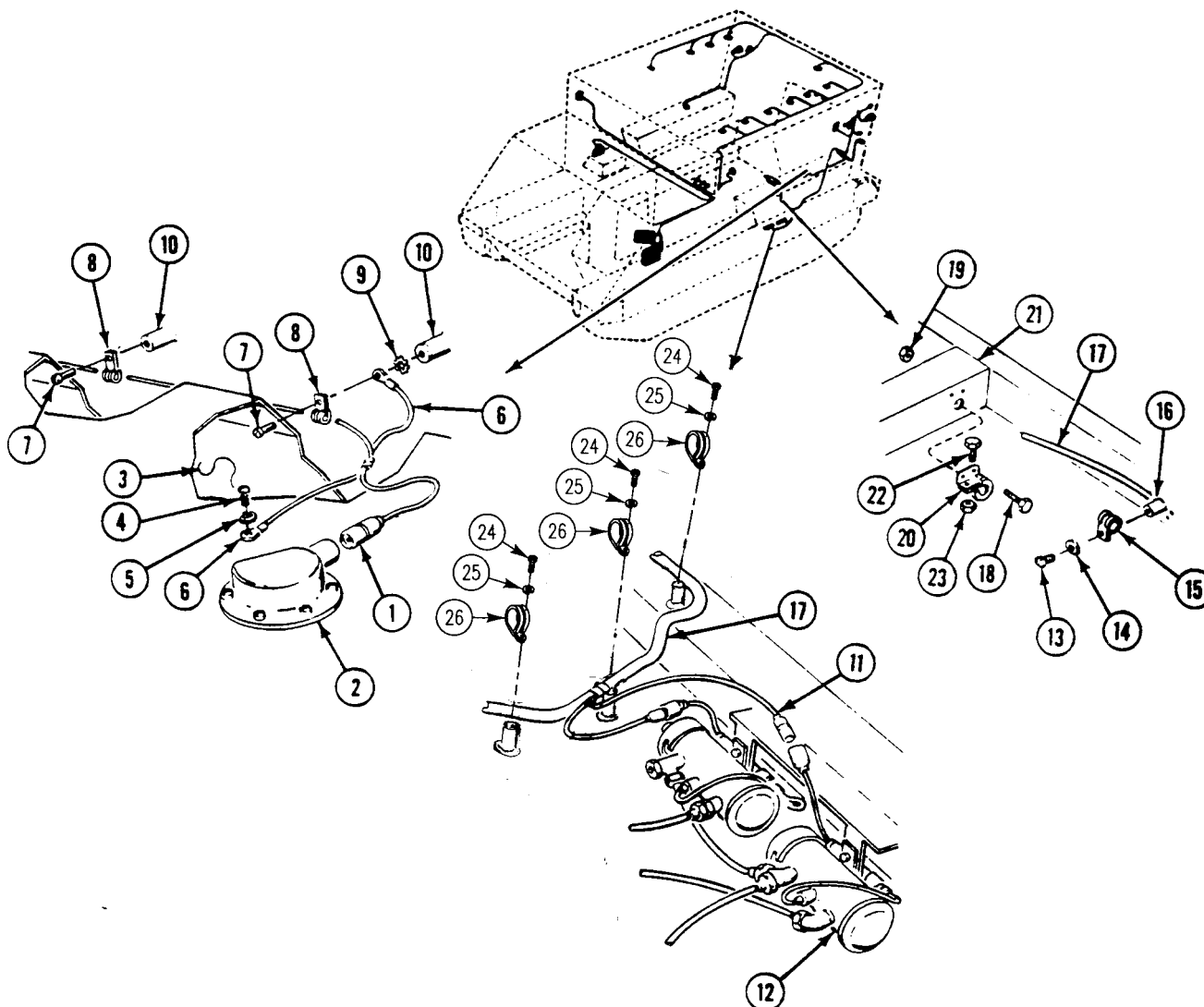

REPLACE REAR MAIN WIRING HARNESS (M577A3 ONLY) — Continued

0363 00

31. Disconnect circuit 21 lead (1), circuit 22 lead (2), circuit 23 lead (3), and circuit 24 lead (4) from trailer wiring harness (5).
32. Disconnect circuit 451 lead (6) from rear bilge pump (7).
33. Remove screw (8), clamp (9), two lockwashers (10), and trailer wiring harness ground lead (11) from weldnut (12). Remove clamp (9) from rear main wiring harness (13). Discard lockwashers.
34. Pull circuit 21 lead (1), circuit 22 lead (2), circuit 23 lead (3), circuit 24 lead (4) and circuit 451 lead (6) through opening in transverse beam.
35. Remove two screws (14) and clamps (15) from two weldnuts (16). Remove clamps (15) from rear main wiring harness (13).
36. Remove eight screws (17), lockwashers (18), clamps (23), and rear main wiring harness (13) from eight weldnuts.
37. Disconnect circuit 38C lead (19) from left dome light (20).
38. Disconnect circuit 38B lead (21) from front blackout light (22).

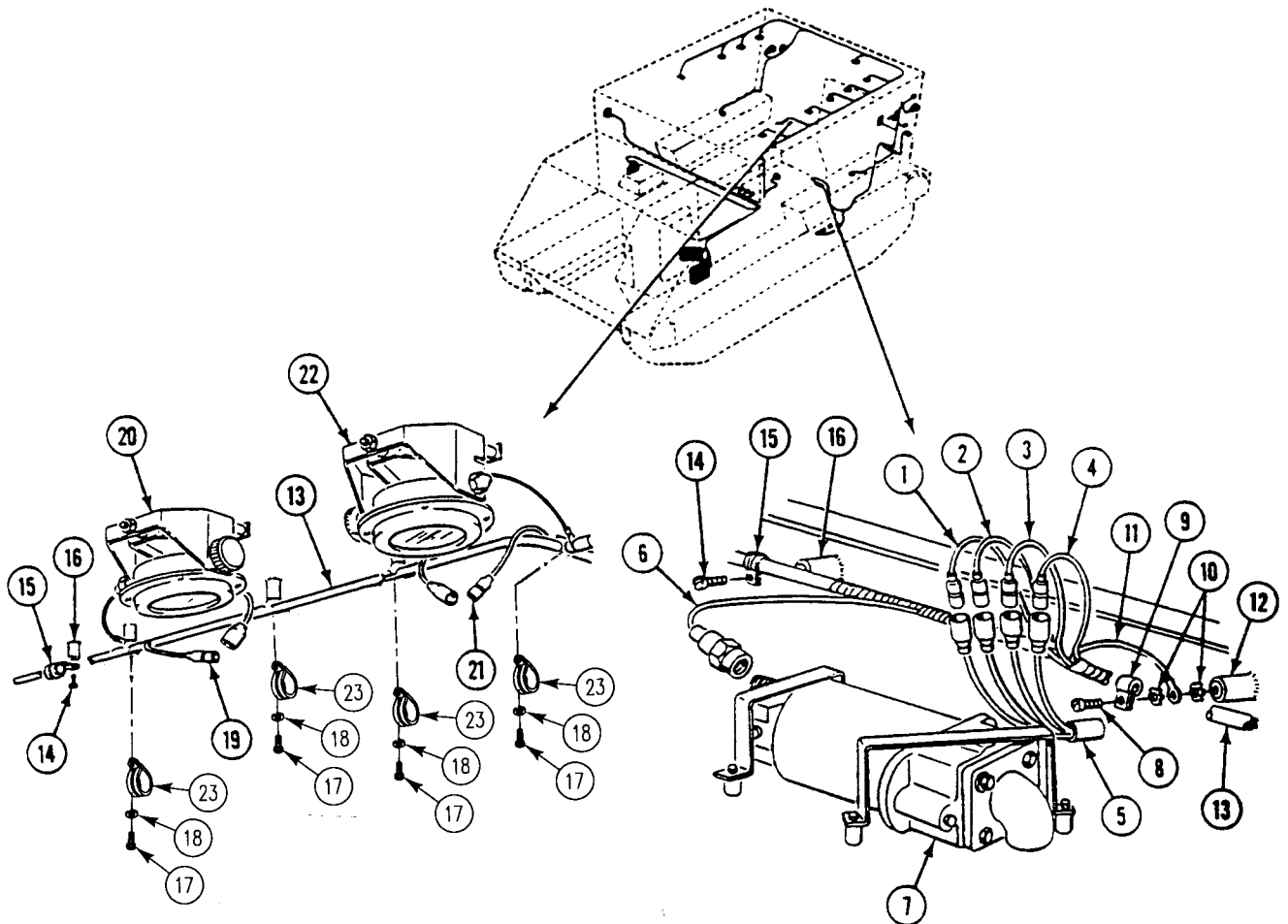

REPLACE REAR MAIN WIRING HARNESS (M577A3 ONLY) — Continued

0363 00

39. Remove four screws (1), nuts (2), and circuit 48A connector (3) from bracket (4).
40. Remove two screws (5), lockwashers (6), and clamps (7) from two weldnuts (8). Remove clamps (7) from circuit 48A lead (9). Discard lockwashers.
41. Remove screw (10), three lockwashers (11), and ground leads (12) from weldnut (13). Discard lockwashers.
42. Remove screw (14), lockwasher (16), clamp (25), rear main wiring harness (15), circuit 48C capacitor (18), and lockwasher (19) from weldnut (20). Discard lockwashers.
43. Remove 12 screws (21), nuts (22), and 3 circuit 48 connectors (23) from bracket (24).

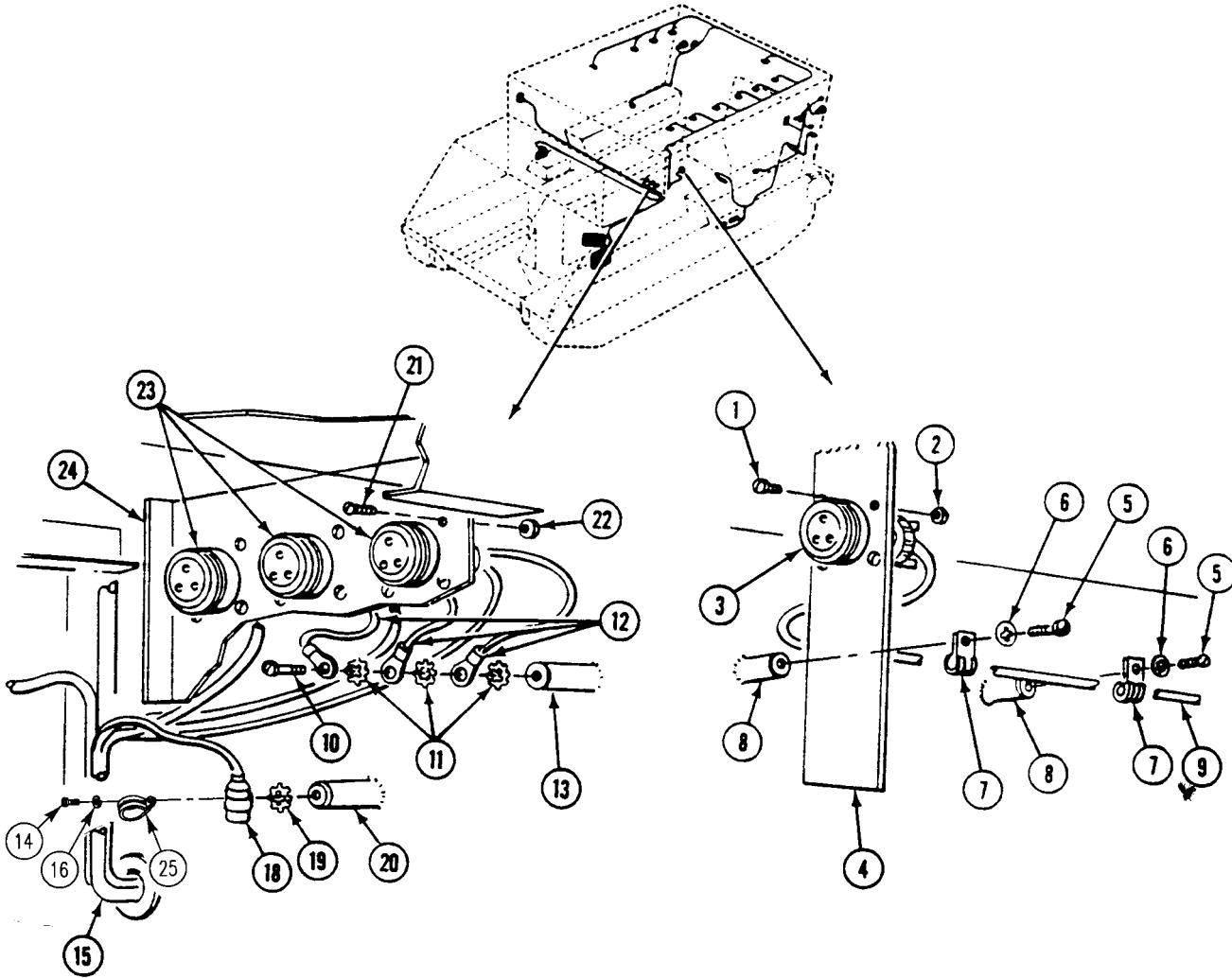

REPLACE REAR MAIN WIRING HARNESS (M577A3 ONLY) — Continued

0363 00

44. Disconnect circuit 59 lead (1) from blower (2).
45. If NBC unit is installed, disconnect circuit 415 lead (3) from NBC unit.
46. Remove screw (4), lockwasher (5), and clamp (6) from weldnut (7). Remove clamp (6) from circuit 59 lead (1) and circuit 415 lead (3). Discard lockwasher.
47. Remove four screws (8), nuts (9), and circuit 48 connector (10) from bracket (11).
48. Remove screw (12), two lockwashers (13), circuit 48 capacitor (14), and ground lead (15) from weldnut (16). Discard lockwashers.
49. Remove six screws (17) and clamps (18) from six weldnuts (19). Remove clamps (18) from circuit 48 lead (20).

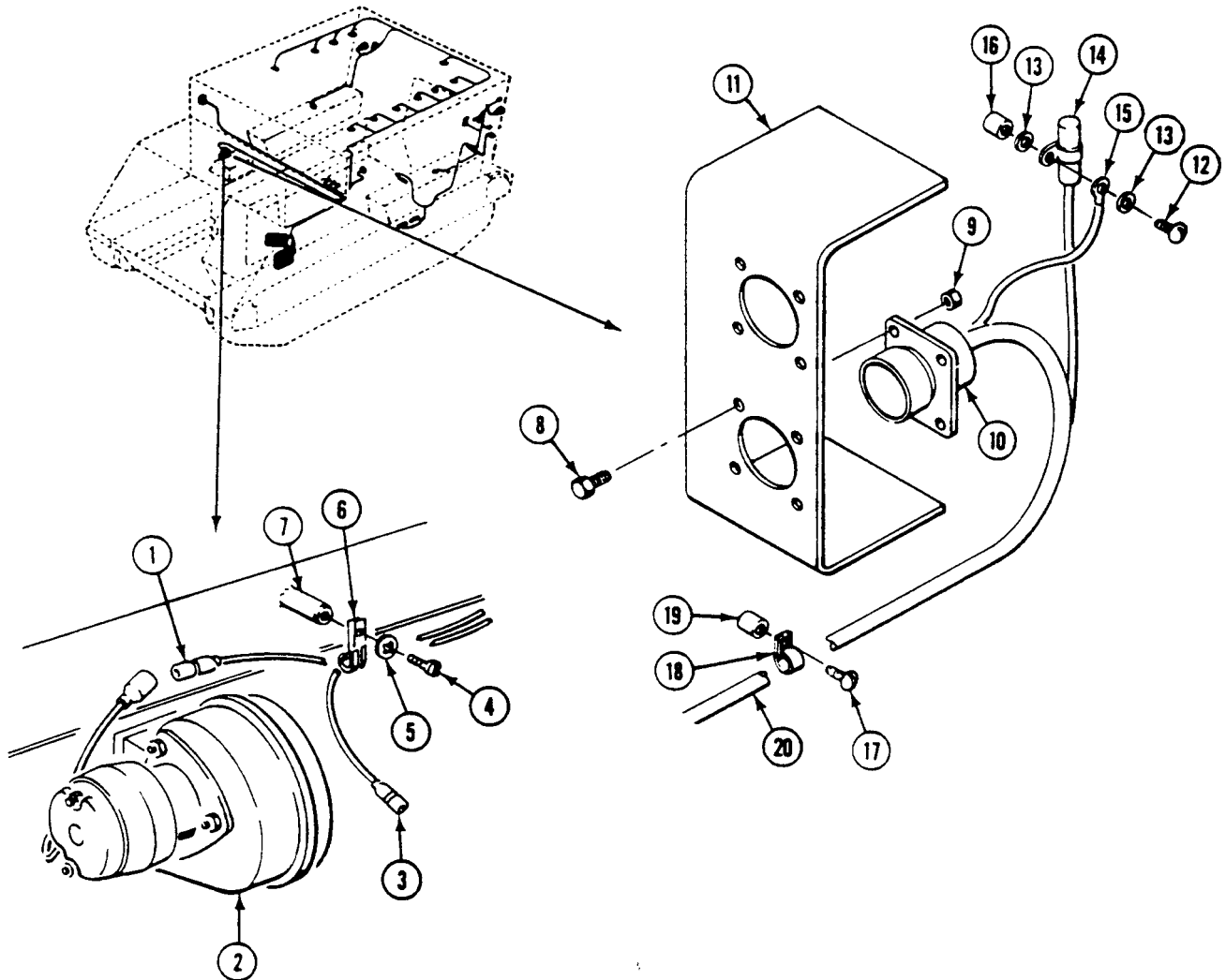

REPLACE REAR MAIN WIRING HARNESS (M577A3 ONLY) — Continued

0363 00

50. Disconnect circuit 400 lead (1) from personnel heater control box.
51. Disconnect circuit 402 lead (2) from personnel heater wiring harness.
52. If NBC unit is installed, disconnect circuit 415 lead (3) from NBC unit.
53. Remove eight locknuts (4), washers (5), and screws (6). Separate master switch panel (7) from distribution box (8). Discard locknuts.
54. Disconnect wiring harness circuit 10 (9) in distribution box (8) from three circuit breakers (10)(11)(12) in master switch panel (7).
55. Disconnect wiring harness (13) from circuit 38E lead (14).

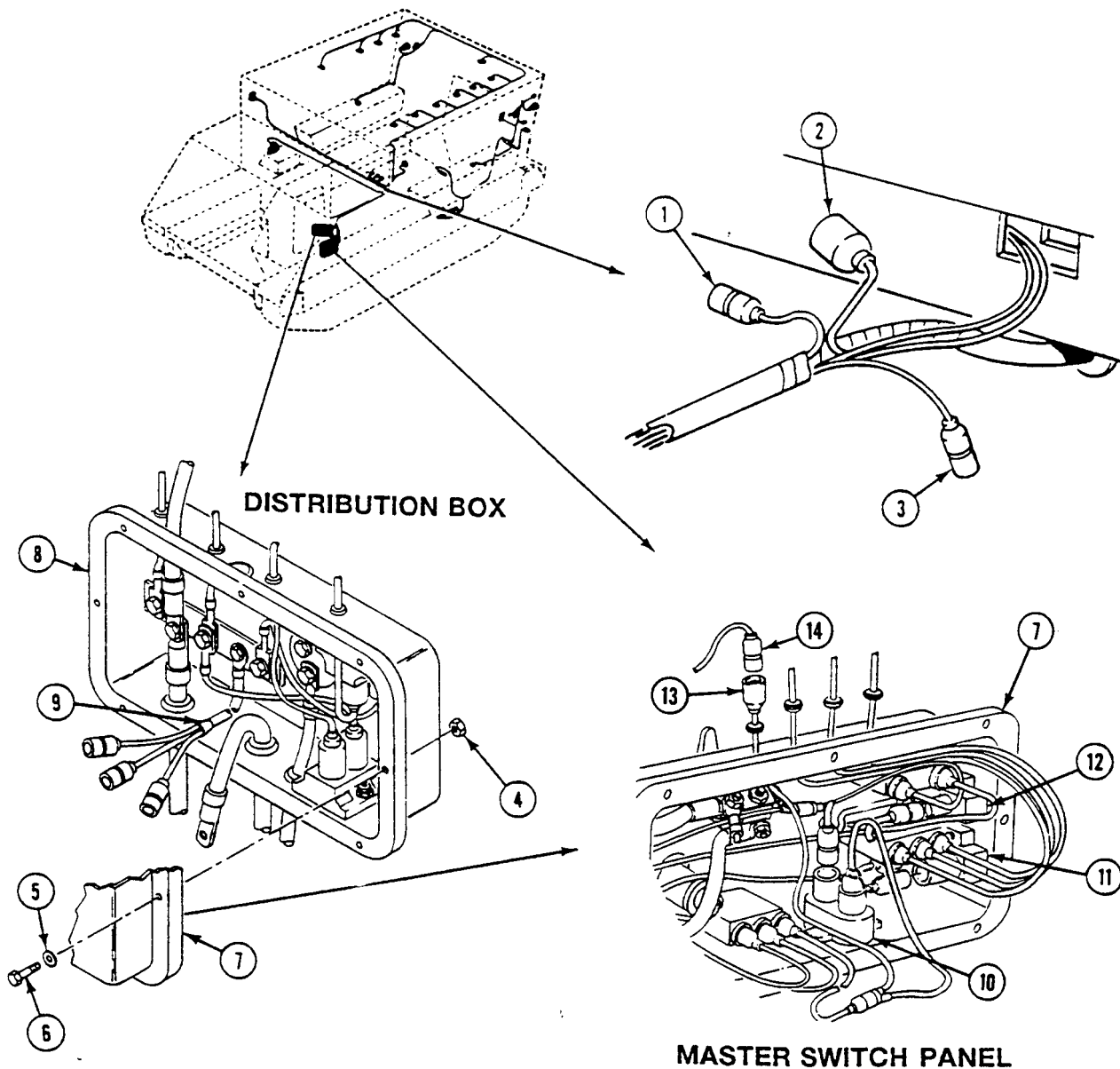

REPLACE REAR MAIN WIRING HARNESS (M577A3 ONLY) — Continued

0363 00

56. Disconnect circuit 59 lead (1) from blower switch (2).
57. Disconnect circuit 37B leads (3) from blower switch (2) and circuit breaker (4).
58. Remove circuit 59 lead (1) and circuit 37B lead (3) and two grommets (5) from master switch panel (6). Discard grommets.
59. Disconnect circuit 37A lead (7) from circuit breaker (8).
60. Disconnect circuit 38 lead (9) and circuit 38A lead (10) from dome light switch (11).
61. Remove circuit 37A lead (7), circuit 38 lead (9), and circuit 38A lead (10) and three grommets (12) from master switch panel (6). Discard grommets.

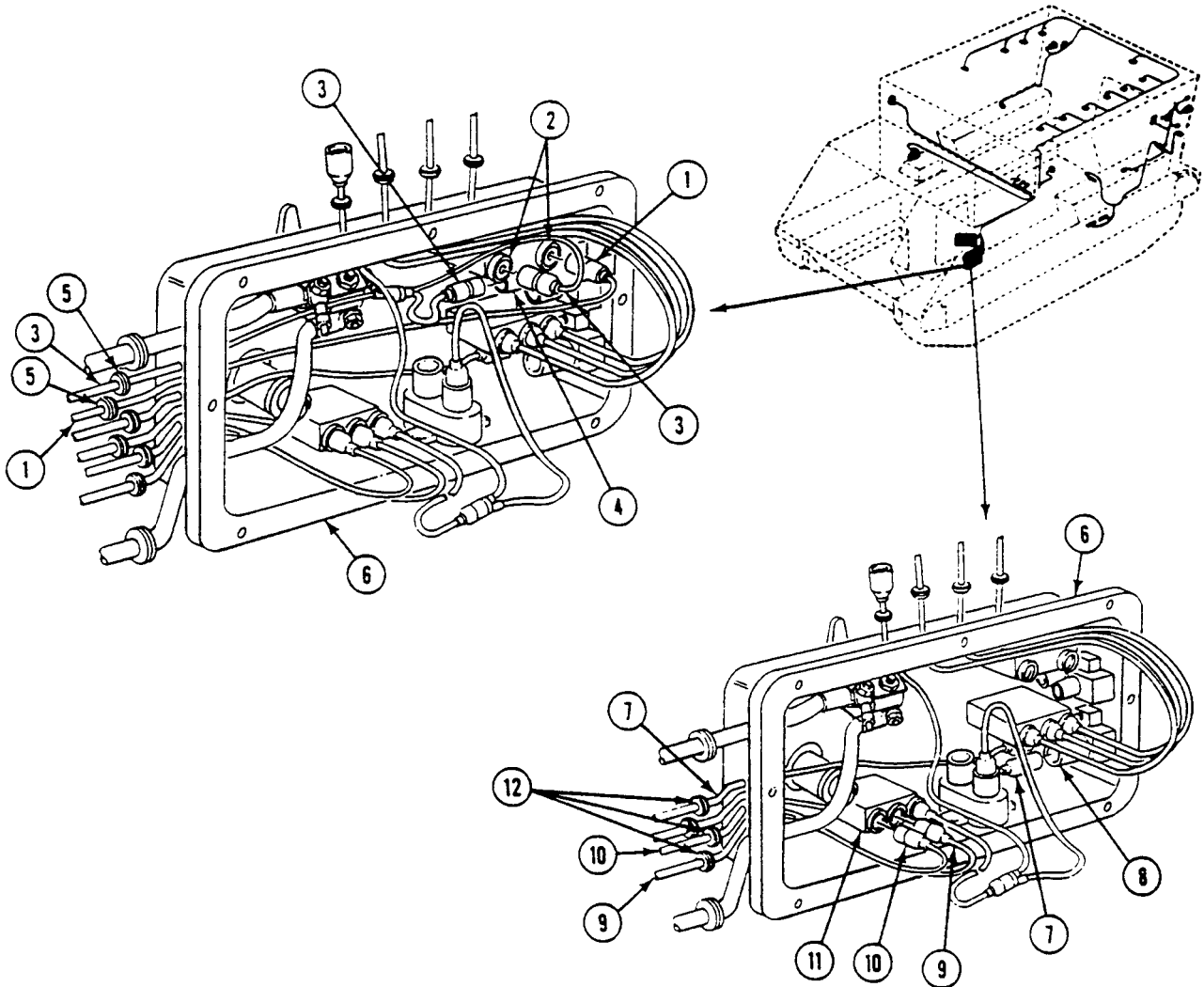

REPLACE REAR MAIN WIRING HARNESS (M577A3 ONLY) — Continued

0363 00

62. Disconnect circuit 28 lead (1), circuit 29 lead (2), and circuit 30 lead (3) from fuel selector switch (4).
63. Remove circuit 28 lead (1), circuit 29 lead (2), circuit 30 lead (3) and three grommets (5) from master switch panel (6). Discard grommets.
64. Disconnect circuit 450 lead (7) from circuit breaker (8).
65. Disconnect circuit 450B lead (9) from circuit breaker (10).
66. Remove circuit 450 lead (7) and grommet (11) from distribution box (12). Discard grommet.
67. Remove circuit 450B lead (9) and grommet (13) from distribution box (12). Discard grommet.

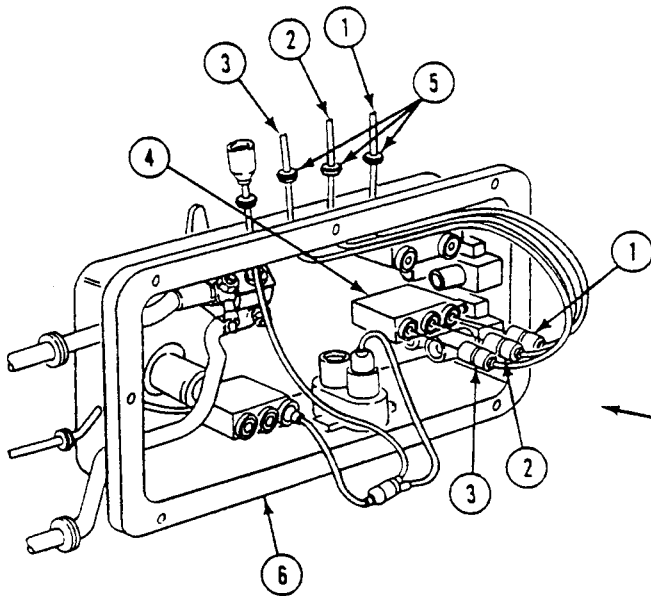

MASTER SWITCH PANEL

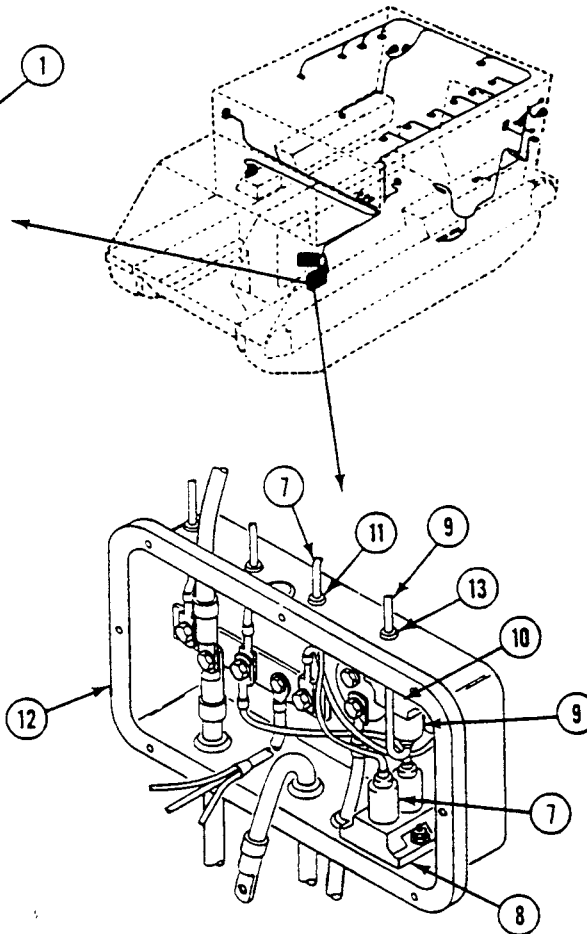

DISTRIBUTION BOX

REPLACE REAR MAIN WIRING HARNESS (M577A3 ONLY) — Continued

0363 00

68. Remove two nuts (1), mounts (2)(3), flat washers (4), and screws (5) that secure instrument panel (6) to two struts (7).
69. Support panel (6). Remove two screws (8), flat washers (9), one lockwasher (10), and ground lead (11), from two mounts (12) and upper support (13). Discard lockwasher.
70. Support panel (6) on two struts (7) to gain access to rear of panel.
71. Disconnect circuit 28 lead (14) from fuel gage.
72. Disconnect circuit 451B lead (15) from rear bilge pump ON indicator light.
73. Disconnect circuit 38 lead (16) from instrument panel wiring harness.
74. Disconnect circuit 450 lead (17), circuit 450B lead (18), and circuit 451A lead (19) from bilge pump switch.
75. Disconnect circuit 21 lead (20), circuit 22 lead (21), circuit 23 lead (22), and circuit 24 lead (23) from front main wiring harness.

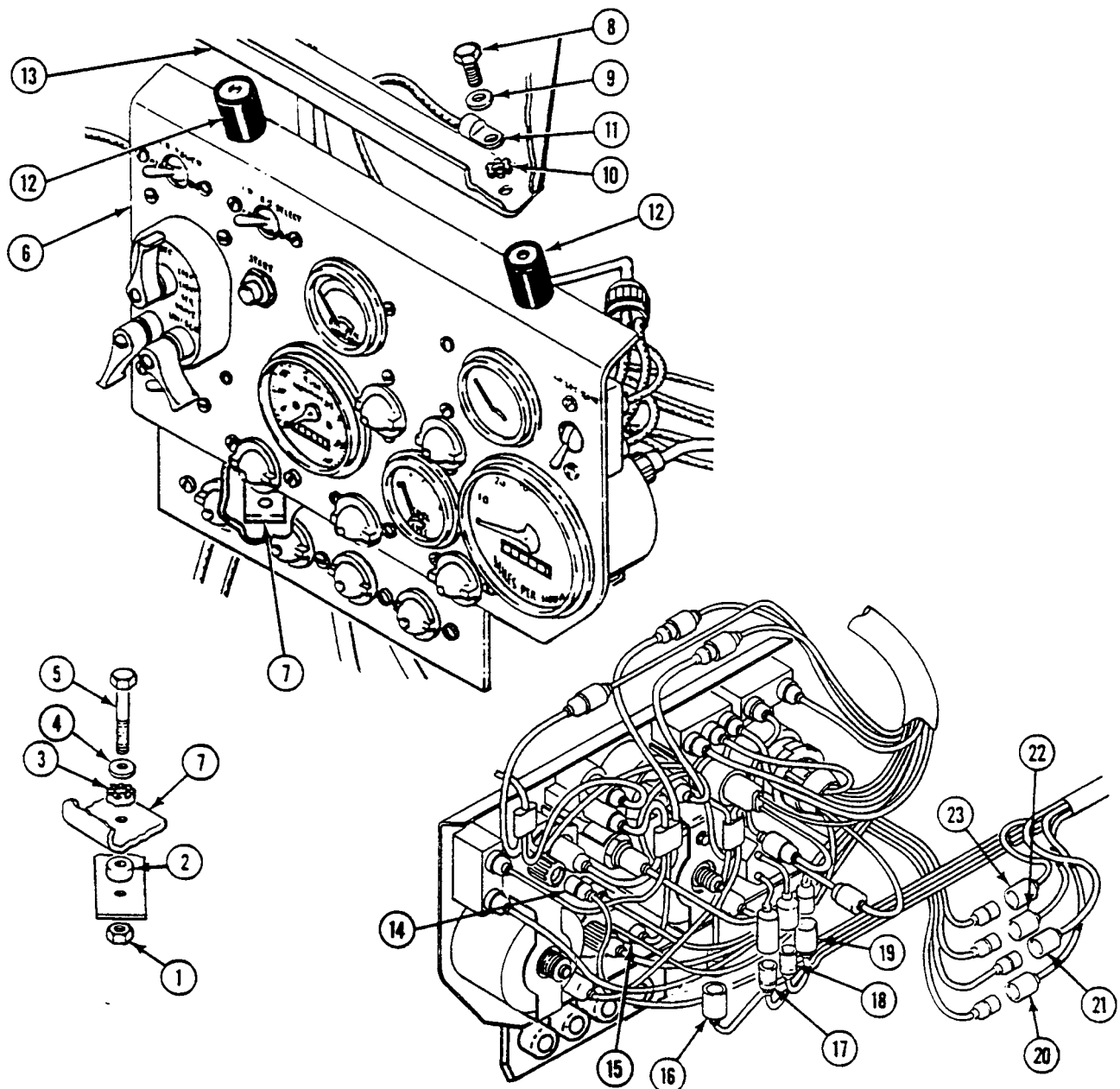

REPLACE REAR MAIN WIRING HARNESS (M577A3 ONLY) — Continued

0363 00

76. Remove screw (1), nut (2), and circuit 6 lead (3) and circuit 48B lead (4) from terminal (5).
77. Remove circuit 48B lead (4) and circuit 6 lead (3) from battery box (6).

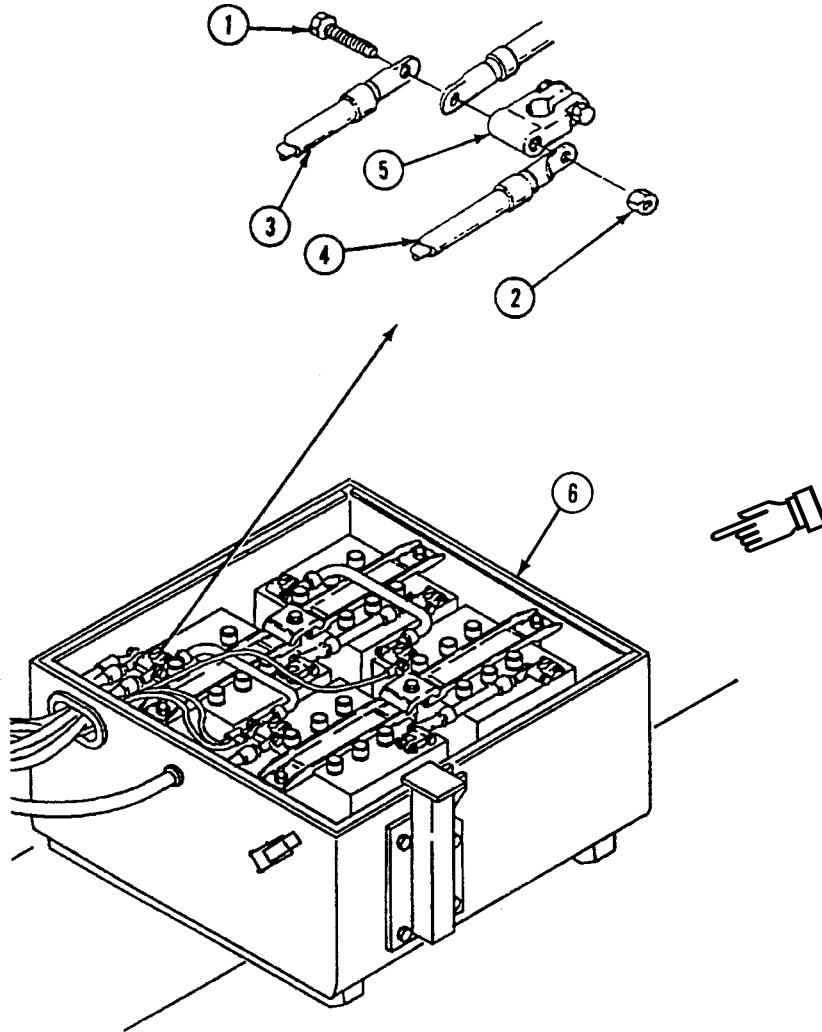

REPLACE REAR MAIN WIRING HARNESS (M577A3 ONLY) — Continued

0363 00

78. Disconnect circuit 38 lead (7), circuit 38B lead (8), and circuit 3C lead (9) from door switch (10).
79. Remove rear main wiring harness (11) from carrier.

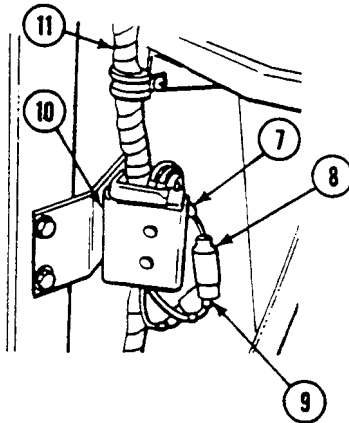
**INSPECTION AND REPAIR**

1. Inspect for damaged connectors and terminals. Repair as needed (WP 0382 00).

INSTALLATION

1. Install rear main wiring harness (11) in carrier.
2. Connect circuit 38 lead (7), circuit 38B lead (8), and circuit 3C lead (9) to ramp door switch (10).

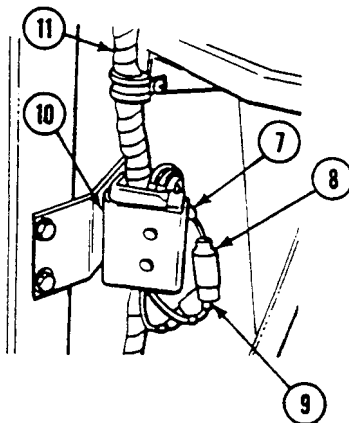

NOTE

Ensure battery terminal has three leads attached before tightening screw and nut.

3. Install circuit 6 lead (3) and circuit 48B lead (4) through grommet (12). Connect three leads to battery terminal (5) with screw (1) and nut (2).

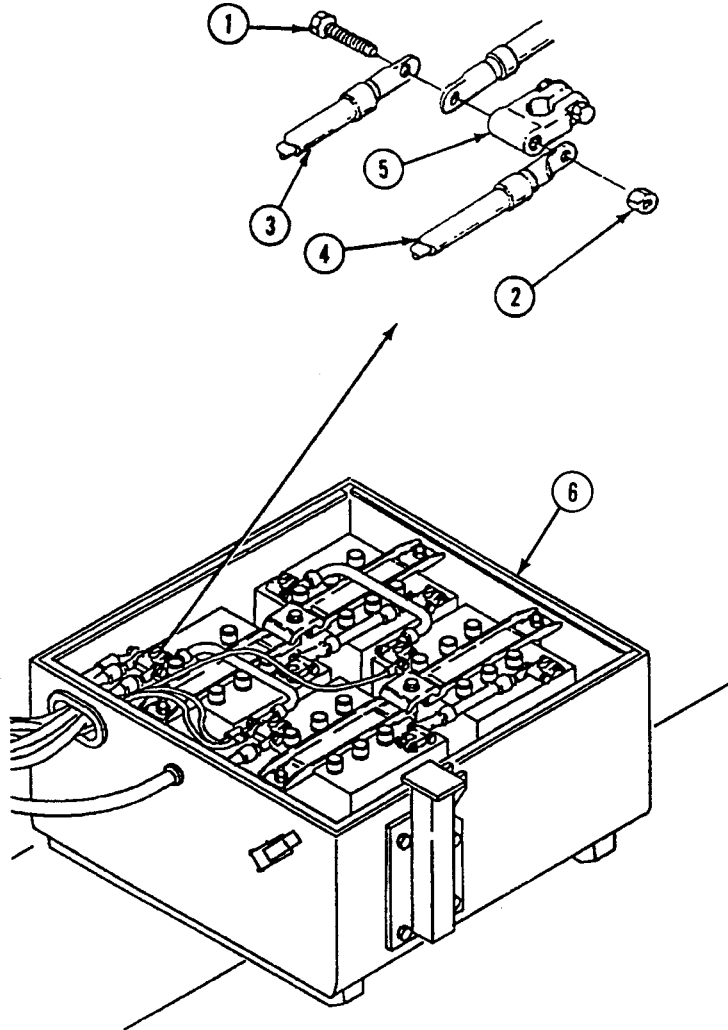

REPLACE REAR MAIN WIRING HARNESS (M577A3 ONLY) — Continued

0363 00

4. Connect circuit 21 lead (1), circuit 22 lead (2), circuit 23 lead (3), and circuit 24 lead (4) to front main wiring harness.
5. Connect circuit 450 lead (5), circuit 450B lead (6), and circuit 451A lead (7) to bilge pump switch.
6. Connect circuit 38 lead (8) to instrument panel wiring harness.
7. Connect circuit 451B lead (9) to rear bilge pump ON indicator light.
8. Connect circuit 28 lead (10) to fuel gage.
9. Support instrument panel (11) on two struts (12).
10. Install ground lead (13) and new lockwasher (14) on upper support (15). Install panel (11) with two mounts (16) on upper support (15). Secure with two screws (17) and flat washers (18).
11. Install panel (11) on two struts (12). Secure with two nuts (19), mounts (20)(21), flat washers (22), and screws (23).

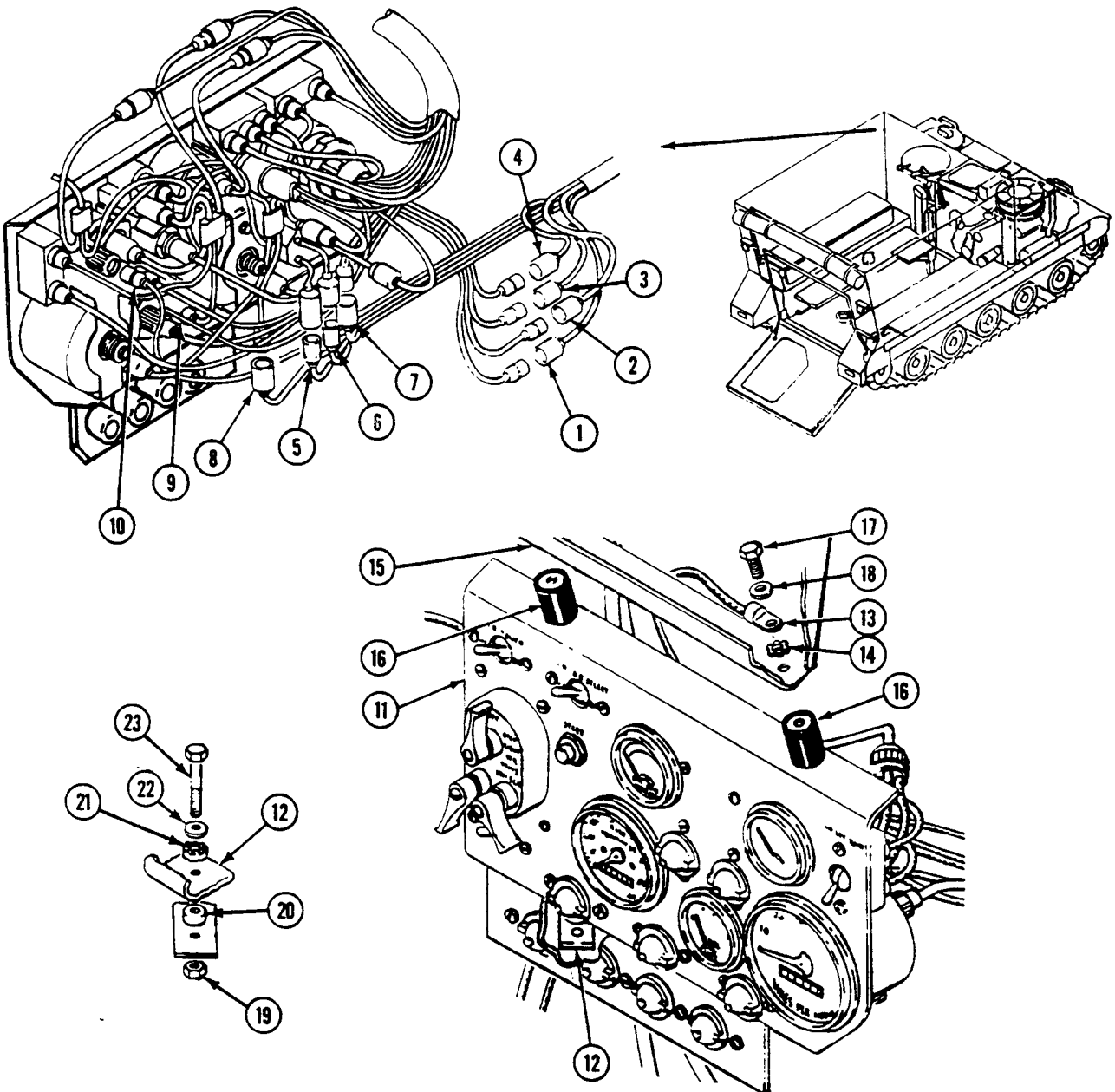

12. Install circuit 450B lead (1) and new grommet (2) in distribution box (3).
13. Install circuit 450 lead (4) and new grommet (5) in distribution box (3).
14. Connect circuit 450B lead (1) to circuit breaker (6).
15. Connect circuit 450 lead (4) to circuit breaker (7).
16. Install circuit 28 lead (8), circuit 29 lead (9), and circuit 30 lead (10) and three new grommets (11) in master switch panel (12).
17. Connect circuit 28 lead (8), circuit 29 lead (9), and circuit 30 lead (10) to fuel selector switch (13).
18. Install circuit 37A lead (14), circuit 38 lead (15), and circuit 38A lead (16) and three new grommets (17) in master switch panel (12).
19. Connect circuit 38 lead (15) and circuit 38A lead (16) to dome light switch (18).
20. Connect circuit 37A lead (14) to circuit breaker (19).

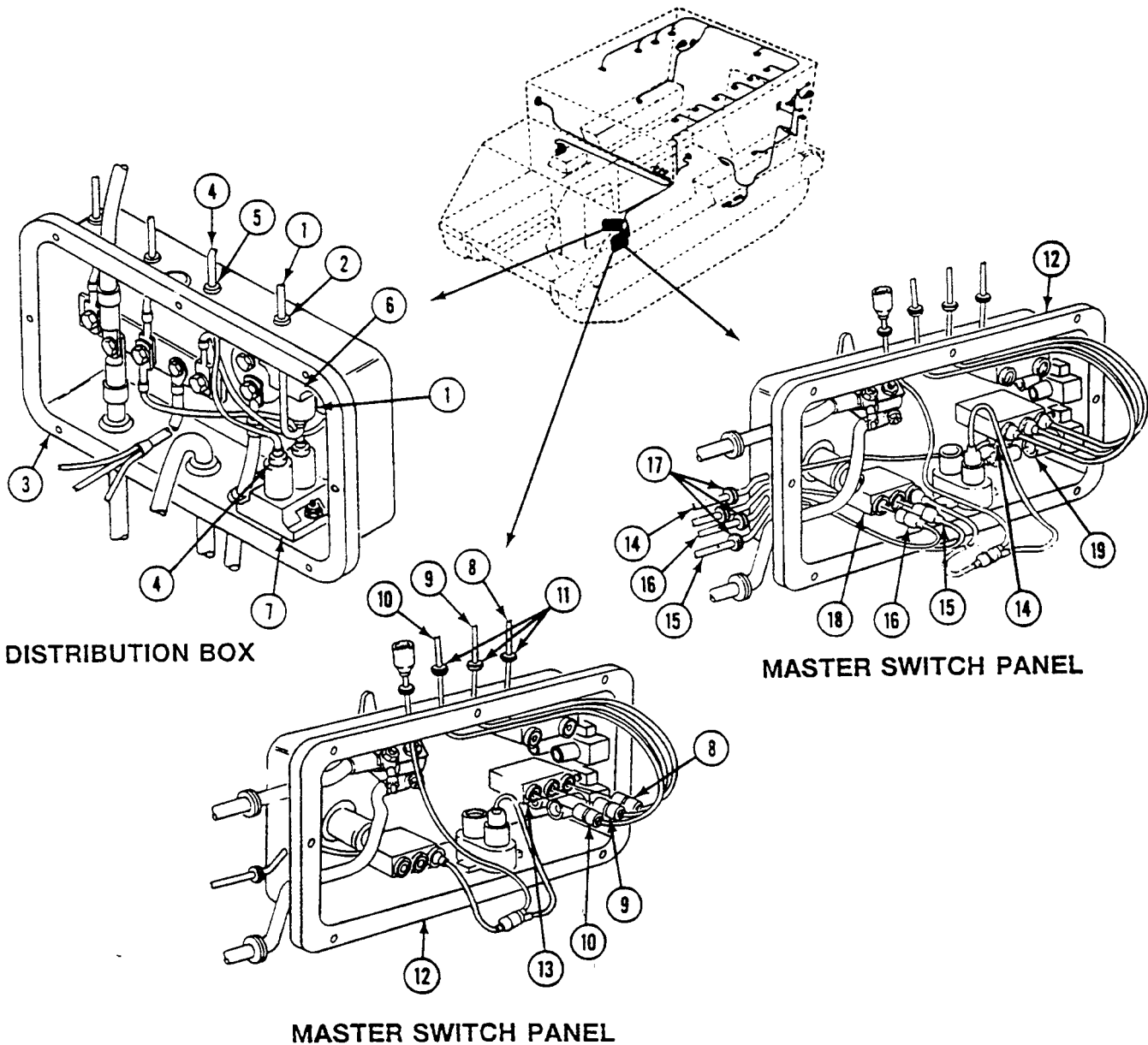

REPLACE REAR MAIN WIRING HARNESS (M577A3 ONLY) — Continued

0363 00

21. Install circuit 59 lead (1) and circuit 37B lead (2) and two grommets (3) in master switch panel (4).
22. Connect circuit 37B lead (2) to blower switch (5) and circuit breaker (6).
23. Connect circuit 59 lead (1) to blower switch (5).

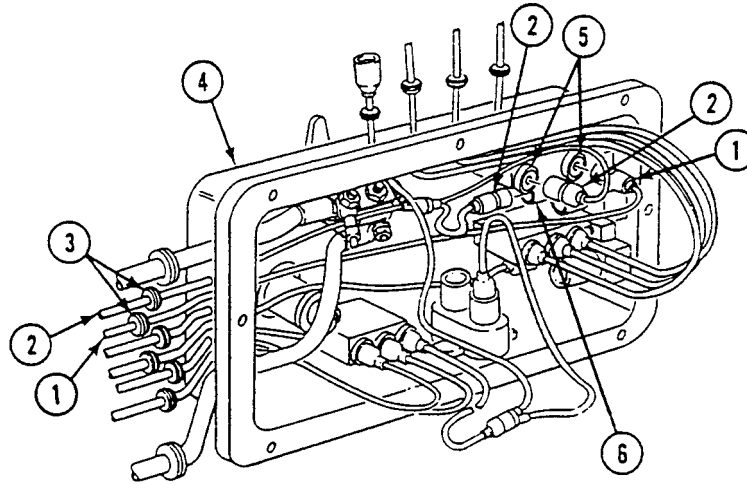
**MASTER SWITCH PANEL**

24. Connect wiring harness (7) to circuit 38E lead (8).
25. Connect wiring harness circuit 10 (9) in distribution box (10) to three circuit breakers (11)(12)(13), in master switch panel (4).

NOTE

Inspect gasket. Replace if damaged.

26. Install master switch panel (4) and gasket (14) on distribution box (10). Secure with eight screws (15), washers (16), and new locknuts (17).

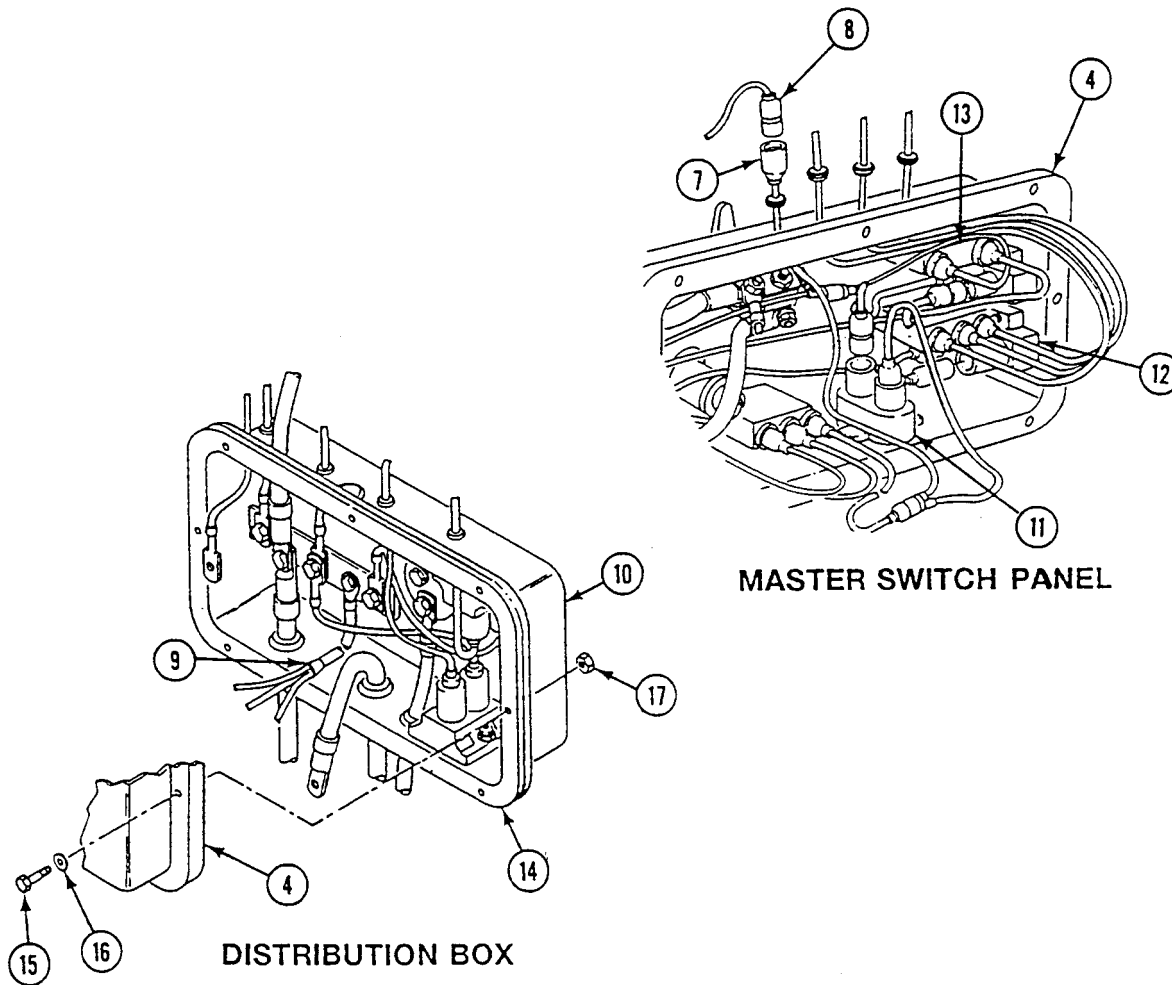

REPLACE REAR MAIN WIRING HARNESS (M577A3 ONLY) — Continued

0363 00

27. If NBC unit is installed, connect circuit 415 lead (1) to NBC unit.
28. Connect circuit 402 lead (2) to personnel heater wiring harness.
29. Connect circuit 400 lead (3) to personnel heater control box.
30. Install six clamps (4) on circuit 48 lead (5). Secure clamps (4) to six weldnuts (6) with six screws (7).
31. Install two new lockwashers (8), circuit 48 capacitor (9), and ground lead (10) on weldnut (11). Secure with screw (12).
32. Install circuit 48 lead connector (13) on bracket (14). Secure with four screws (15) and nuts (16).

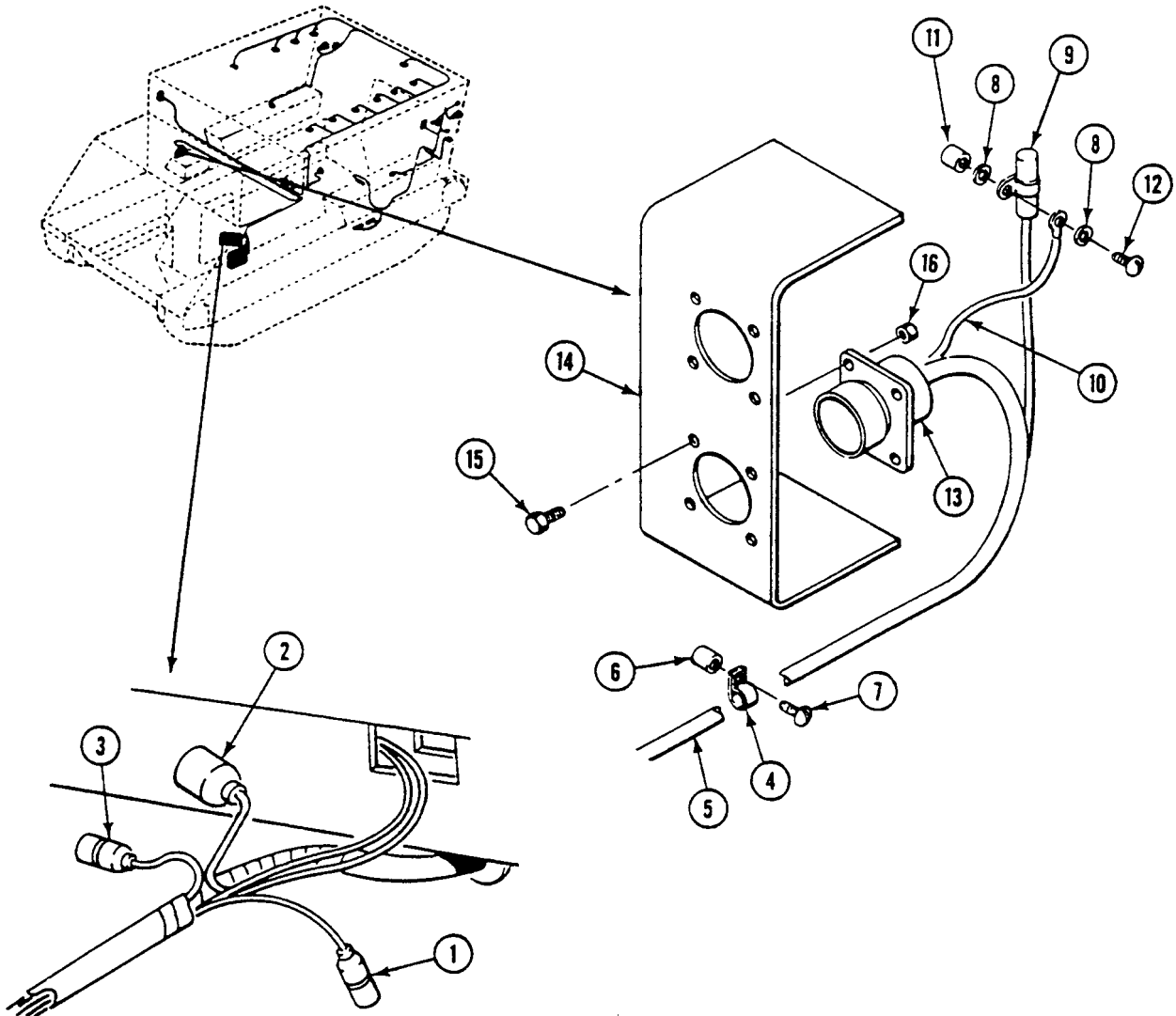

REPLACE REAR MAIN WIRING HARNESS (M577A3 ONLY) — Continued

0363 00

33. Install circuit 415 lead (1) and circuit 59 lead (2) in clamp (3). Secure clamp (3) on weldnut (4) with new lockwasher (5) and screw (6).
34. If NBC unit is installed, connect circuit 415 lead (1) to NBC unit.
35. Connect circuit 59 lead (2) to blower (7).
36. Install three circuit 48 connectors (8) on bracket (9). Secure with 12 screws (10) and nuts (11).
37. Install clamp (12), circuit 48C capacitor (13), and new lockwasher (14) on weldnut (15). Secure with screw (16).
38. Install rear main wiring harness (17) on weldnut. Secure clamp (12) with new lockwasher (18) and screw (23).
39. Install three ground leads (19) and new lockwashers (20) on weldnut (21). Secure with screw (22).

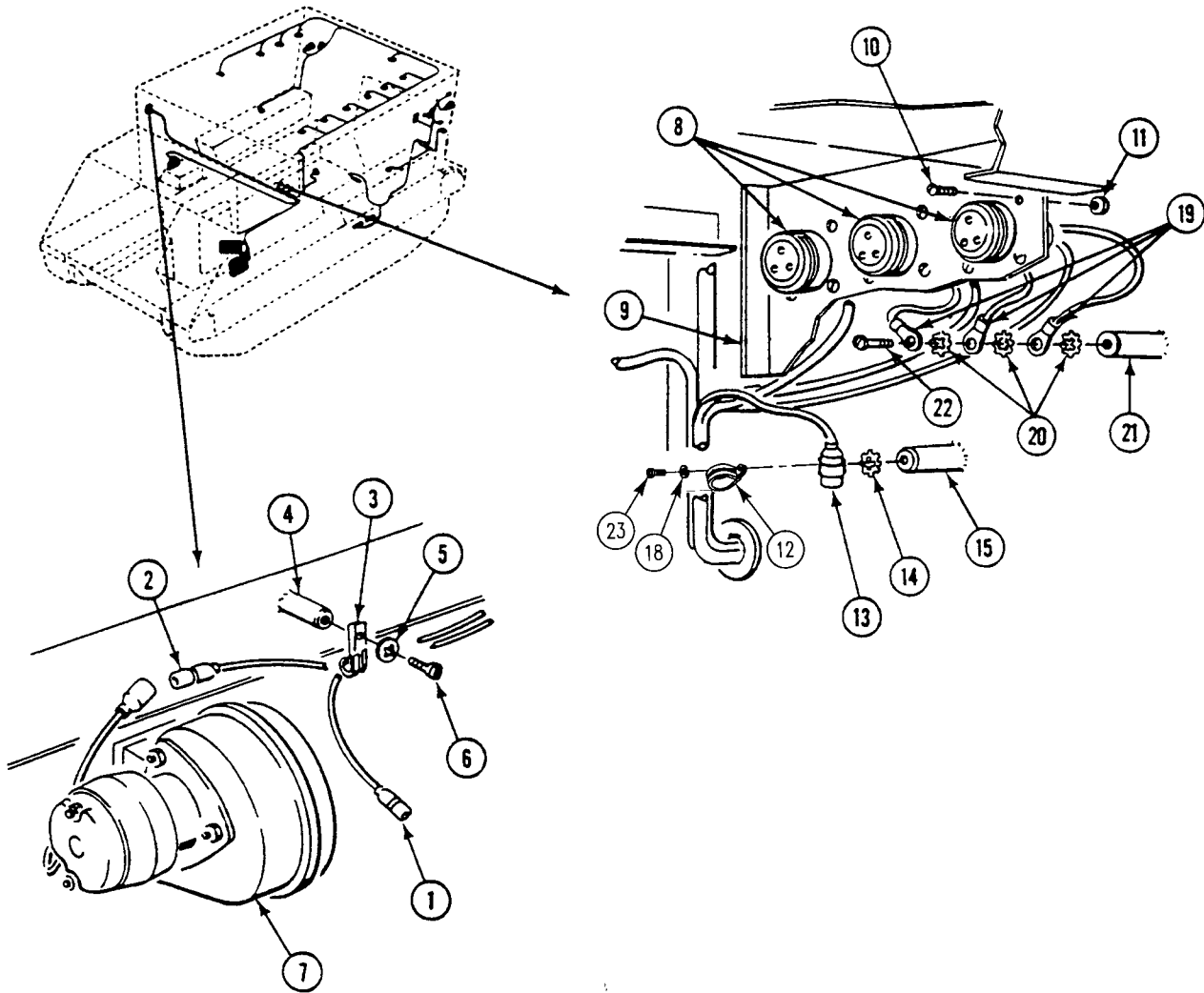

REPLACE REAR MAIN WIRING HARNESS (M577A3 ONLY) — Continued

0363 00

40. Install circuit 48A lead (1) in two clamps (2). Secure clamps (2) on two weldnuts (3) with two screws (4) and new lockwashers (5).
41. Install circuit 48A connector (6) on bracket (7). Secure with four screws (8) and nuts (9).
42. Connect circuit 38B lead (10) to front blackout light (11).
43. Connect circuit 38C lead (12) to left dome light (13).
44. Install rear main wiring harness (14) on weldnuts. Secure eight clamps (15) with eight new lockwashers (16) and screws (20).
45. Install two clamps (17) on rear main wiring harness (14). Secure clamps (17) on two weldnuts (18) with screws (19).

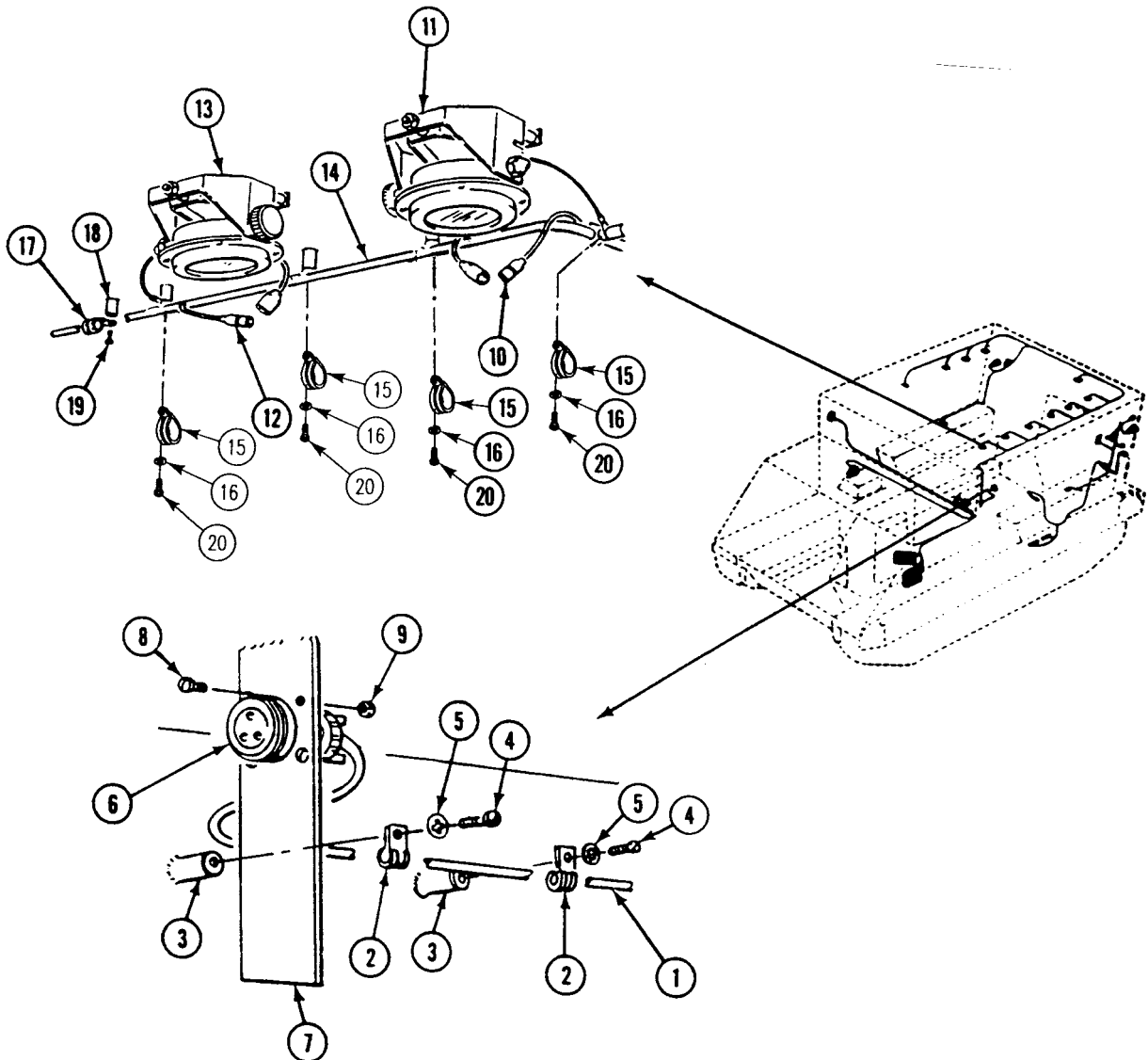

REPLACE REAR MAIN WIRING HARNESS (M577A3 ONLY) — Continued

0363 00

46. Pull circuit 21 lead (1), circuit 22 lead (2), circuit 23 lead (3), circuit 24 lead (4), and circuit 451 lead (5) through opening in floor transverse beam (6).
47. Install clamp (7) on rear main wiring harness (8). Secure clamp (7) and trailer wiring harness ground lead (9) on weldnut (10) with two new lockwashers (11) and screw (12).
48. Connect circuit 451 lead (5) to rear bilge pump (13).
49. Connect circuit 21 lead (1), circuit 22 lead (2), circuit 23 lead (3), and circuit 24 lead (4) to trailer wiring harness (14).
50. Install clamp (15) on rear main wiring harness (8). Secure clamp with screw (16) and nut (17).
51. Install clamp (15) and rear main wiring harness (8) on transverse beam (6). Secure with two screws (18) and nuts (19).
52. Install clamp (20) on rear main wiring harness (8). Secure clamp on weldnut (21) with new lockwasher (22) and screw (23).

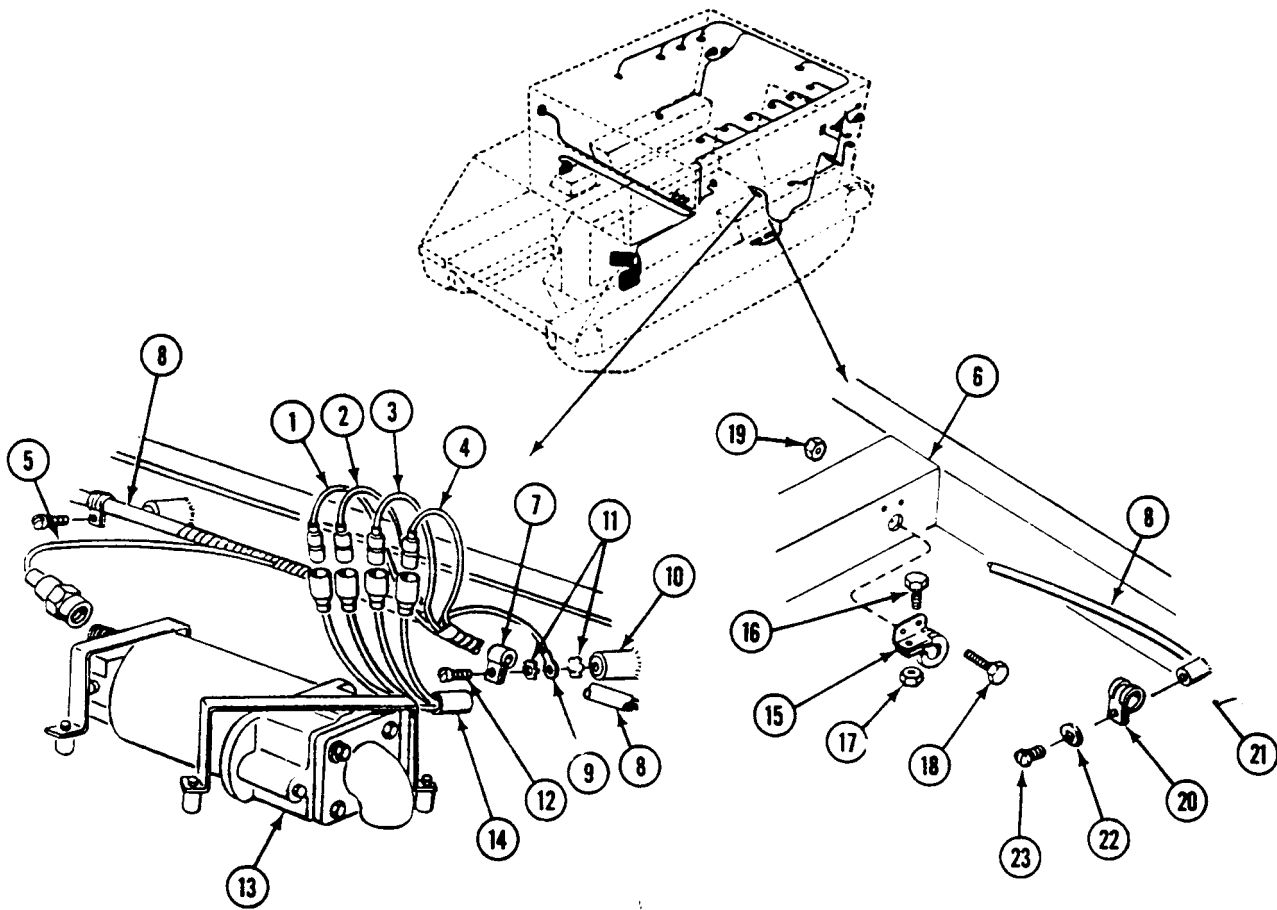

REPLACE REAR MAIN WIRING HARNESS (M577A3 ONLY) — Continued

0363 00

53. Connect circuit 402 lead (1) to personnel heater fuel pump (2).
54. Install two clamps (3) on circuit 30 lead (4). Secure clamps (3) and ground lead (5) on two weldnuts (6) with two new lockwashers (7) and screws (8).
55. Install ground lead (5) on left fuel quantity sending unit (9). Secure with screw (10), new lockwasher (11), and new lockwire (12).
56. Connect circuit 30 lead (4) on left sending unit (9).

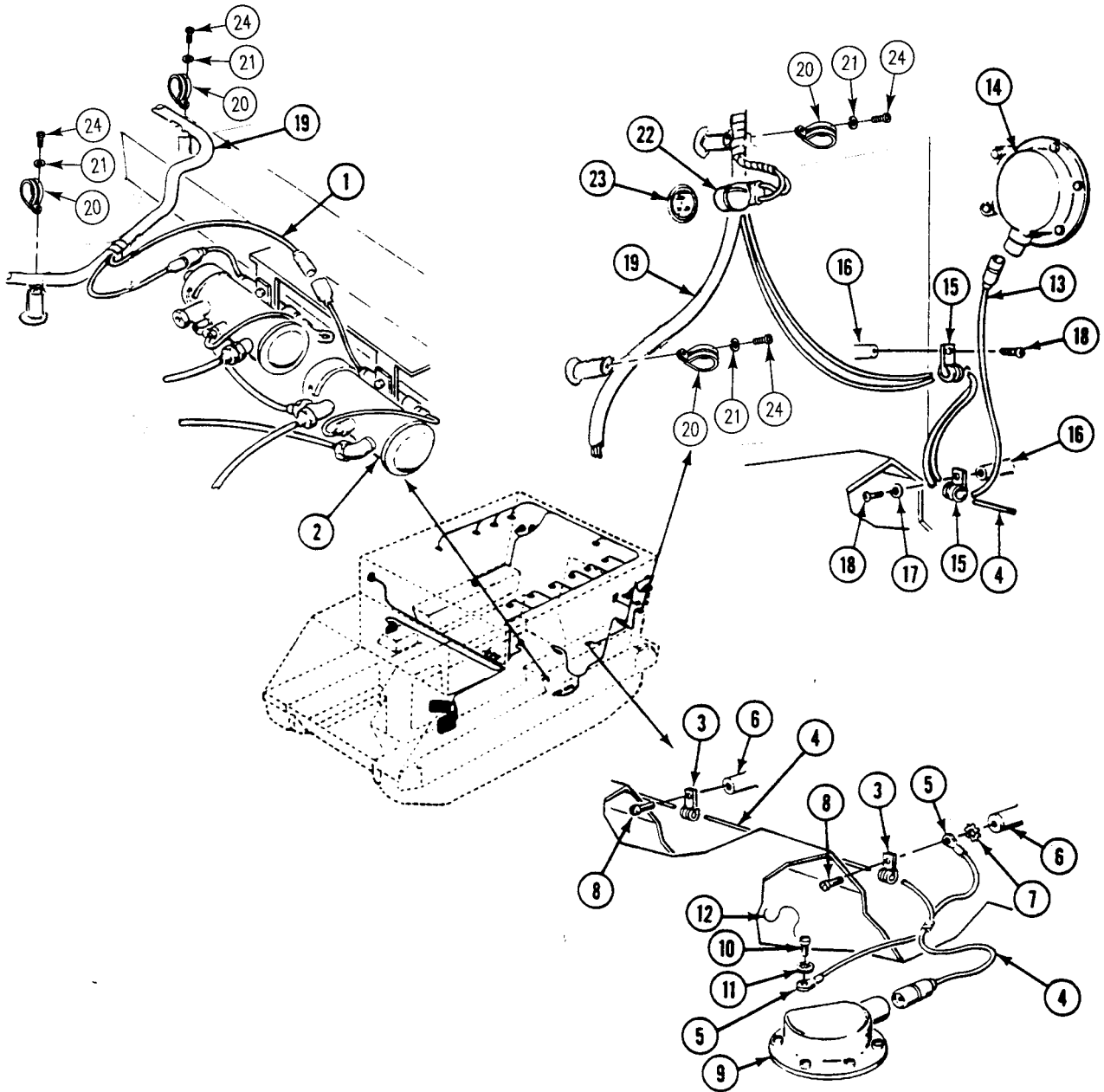

REPLACE REAR MAIN WIRING HARNESS (M577A3 ONLY) — Continued

0363 00

57. Connect circuit 509 lead (13) to buzzer (14).
58. Install two clamps (15) on circuit 30 lead (4) and Circuit 509 lead (13). Secure on two weldnuts (16) with one new lockwasher (17) and two screws (18).
59. Install rear main wiring harness (19) on seven weldnuts. Secure seven clamps (20) with new lockwashers (21) and screws (24).
60. Connect circuit 509 and 509A connector (22) to buzzer switch (23).

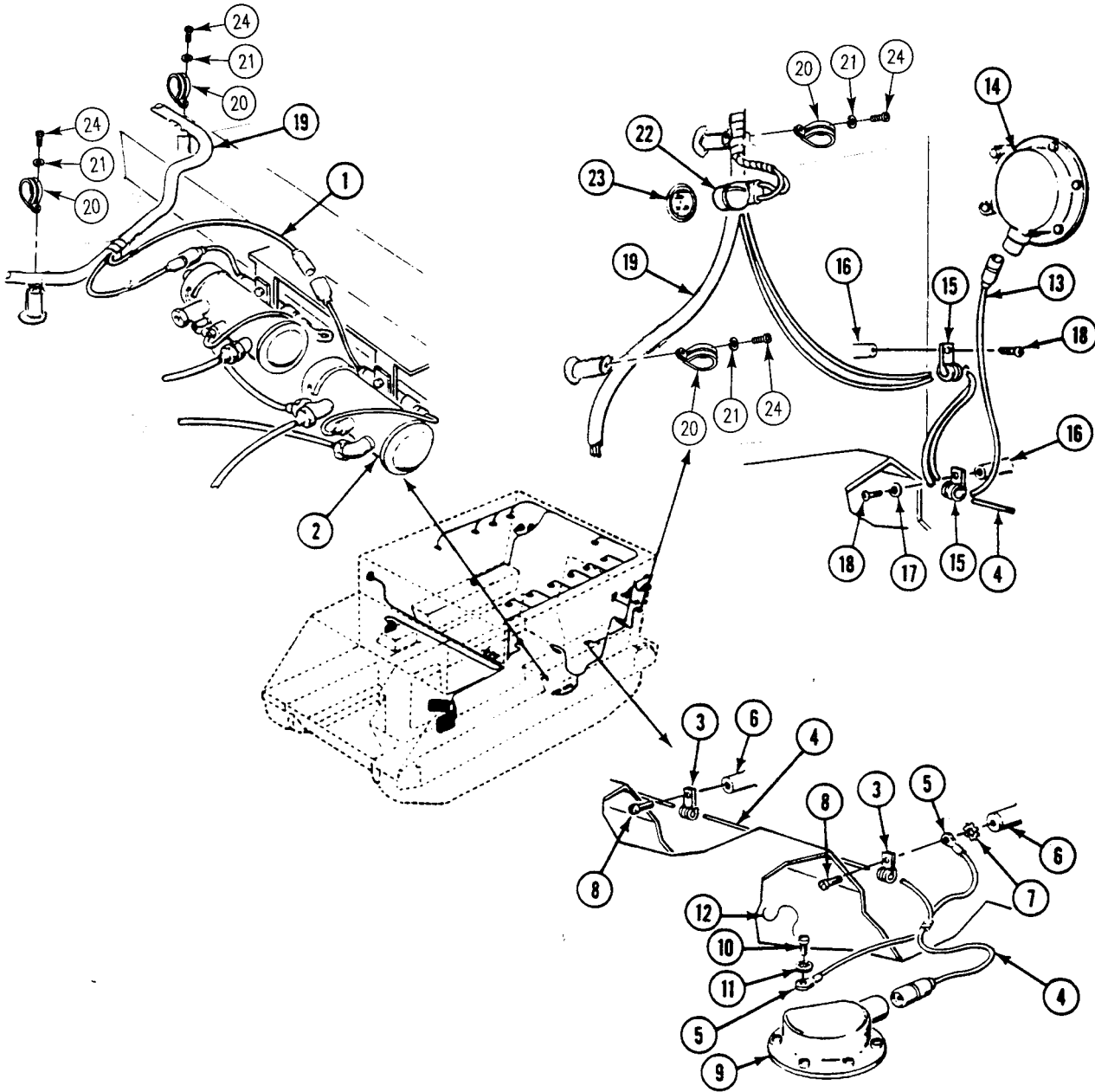

REPLACE REAR MAIN WIRING HARNESS (M577A3 ONLY) — Continued

0363 00

61. Connect circuit 38C lead (1) and circuit 38E lead (2) to blackout dome light switch (3).
62. Connect circuit 38 lead (4), circuit 38A lead (5), and circuit 38E lead (6) to dome light switch (7).
63. Connect circuit 21 lead (8), circuit 22 lead (9), and circuit 24 lead (10) to left tail light leads (11).
64. Connect circuit 37B lead (12) to left utility outlet lead (13).
65. Install two circuit 48 connectors (14) on bracket (15). Secure with eight screws (16) and nuts (17).
66. Install two new lockwashers (18) and ground leads (19) on weldnut (20). Secure with screw (21).
67. Install rear main wiring harness (17) on seven weldnuts. Secure seven clamps (12) with new lockwashers (18) and screws (23).

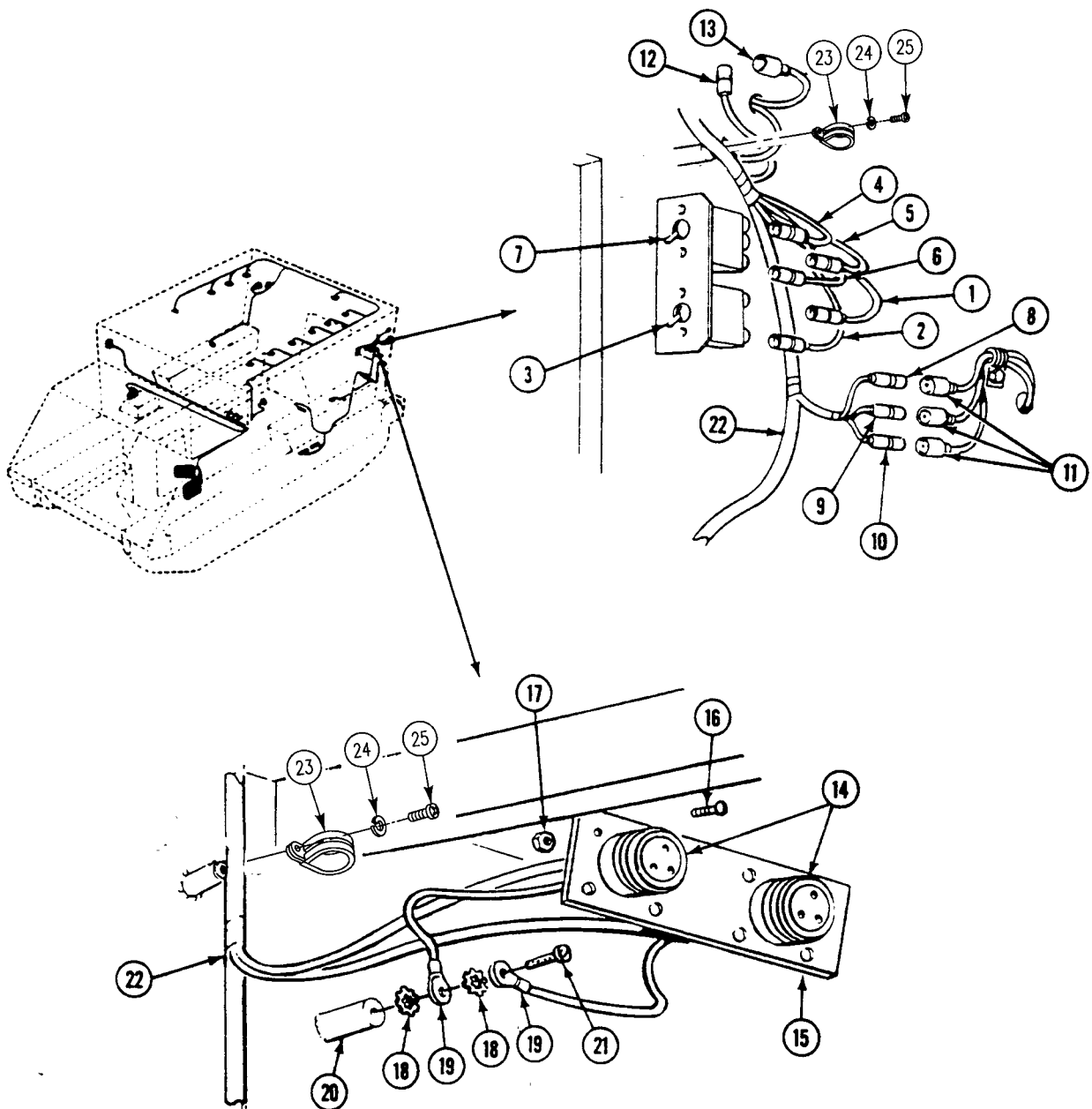

REPLACE REAR MAIN WIRING HARNESS (M577A3 ONLY) — Continued

0363 00

68. Connect four circuit 38C leads (1) to four left side dome lights (2).
69. Install two clamps (3) on circuit 38B lead (4). Secure clamps (3) and ground lead (5) on two weldnuts (6) with one new lockwasher (7) and two screws (8).

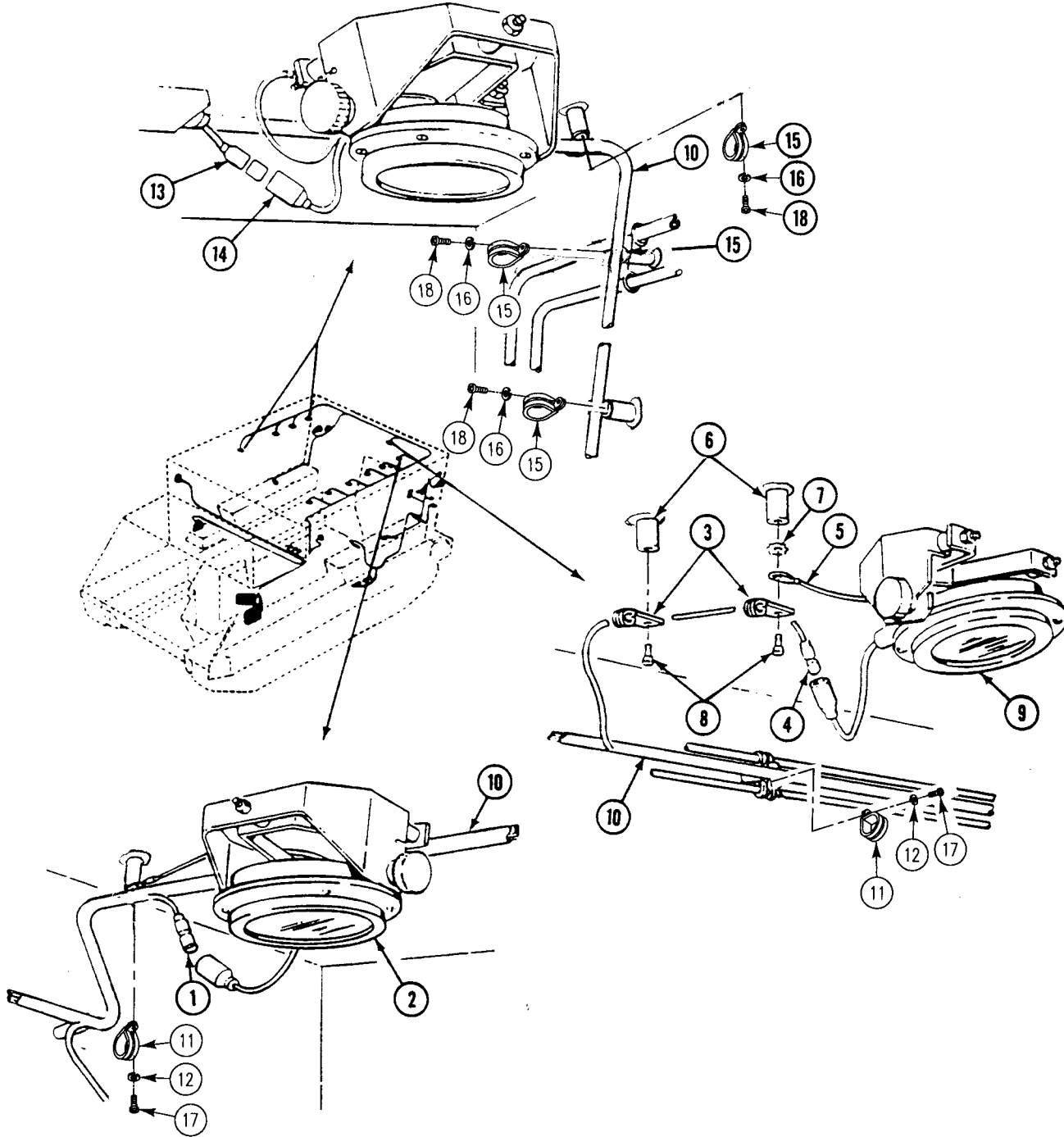

REPLACE REAR MAIN WIRING HARNESS (M577A3 ONLY) — Continued

0363 00

70. Connect circuit 38B lead (4) to rear blackout dome light (9).
71. Secure rear main wiring harness (10) on six weldnuts using six clamps (11) with new lockwashers (12) and screws (17).
72. Connect four circuit 38C leads (13) to four right side dome lights (14).
73. Secure rear main wiring harness (10) on eight weldnuts using eight clamps (15) with new lockwashers (16) and screws (18).

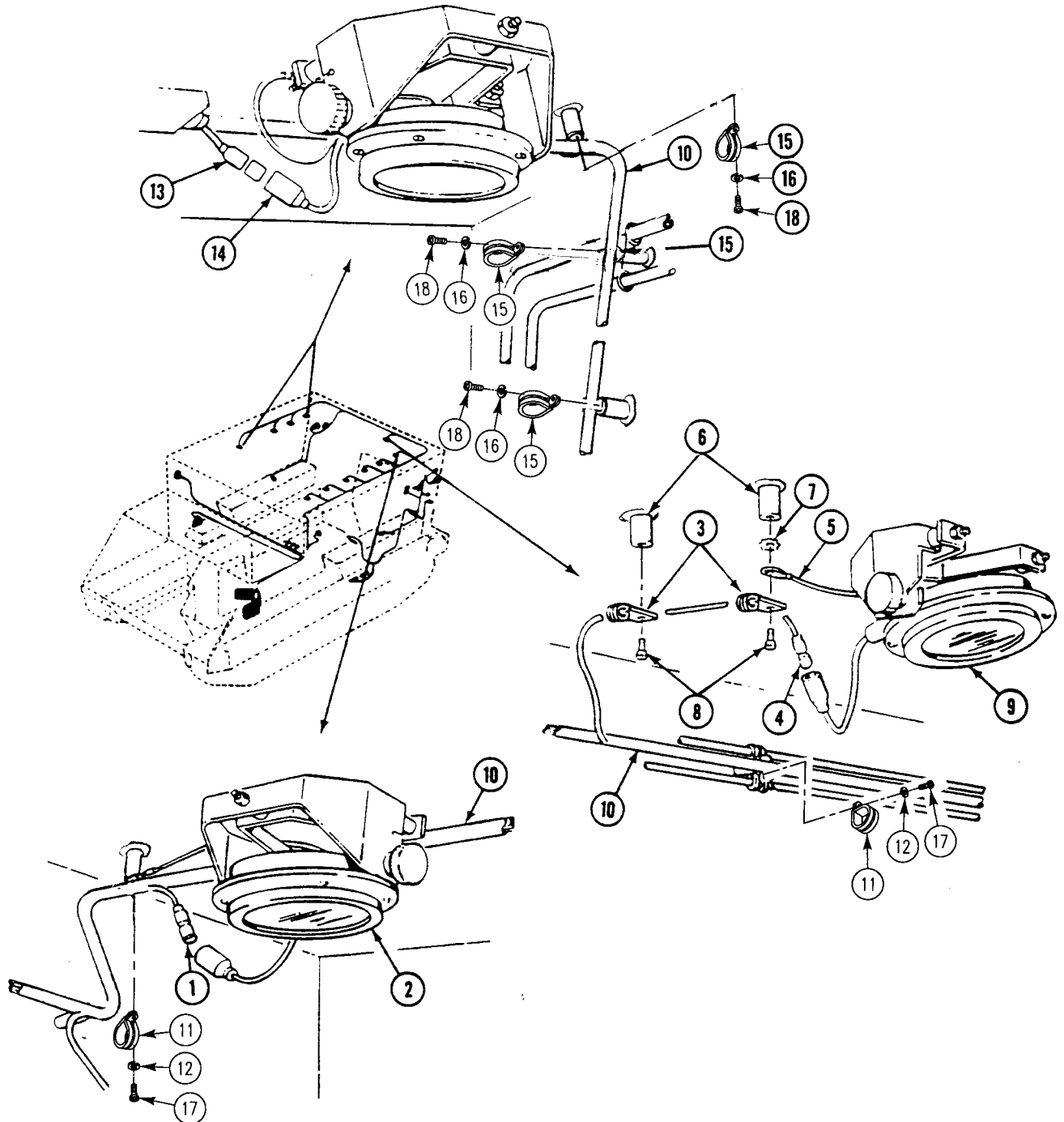

REPLACE REAR MAIN WIRING HARNESS (M577A3 ONLY) — Continued

0363 00

74. Connect circuit 37A lead (1) to right utility outlet lead (2).
75. If NBC unit is installed, connect circuit 415 lead (3) to NBC unit switch.
76. Connect circuit 23 lead (4) and circuit 24 lead (5) to right tail light (6).
77. Install three clamps (7) on circuit 29 lead (8). Secure ground lead (9) and clamps (7) on three weldnuts (10) with two new lockwashers (11), three screws (12), and flat washers (13).
78. Install ground lead (9) on right fuel quantity sending unit (14). Secure with screw (15), new lockwasher (16), and new lockwire (17).
79. Connect circuit 29 lead (8) on right fuel quantity sending unit (14).

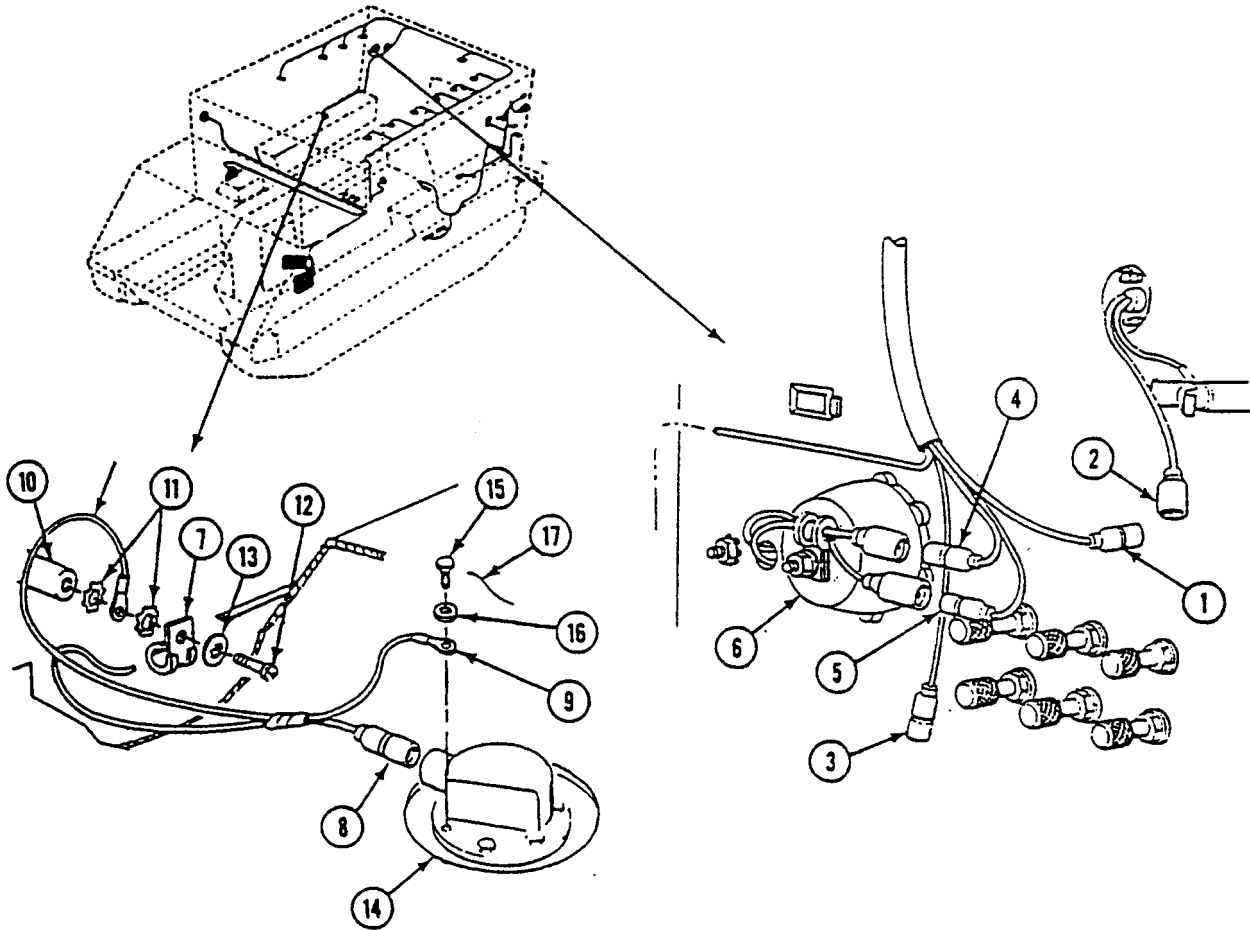

FOLLOW-THROUGH STEPS

1. Install rear floor plate (WP 0539 00).
2. Connect battery ground lead (WP 0338 00).
3. Install battery access cover (see your -10).
4. Turn MASTER SWITCH to ON (see your -10. Check that electrical system works properly).
5. Start engine (see your -10).
6. Raise and lock ramp (see your -10).
7. Stop engine (see your -10).

END OF TASK

REPLACE REAR MAIN WIRING HARNESS (M1064A3 ONLY)

0364 00

THIS WORK PACKAGE COVERS:

- Removal (page 0364 00-1).
- Inspection and Repair (page 0364 00-13).
- Installation (page 0364 00-13).

INITIAL SETUP:

Maintenance Level

Unit

References

See your -10

Tools and Special Tools

General Mechanic's Tool Kit (WP 0926 00, Item 65)

Equipment Condition

Materials/Parts

- Fibrous twine (WP 0928 00, Item 31)
- Insulation tape (WP 0928 00, Item 39)
- Grommet (4)
- Locknut (21)
- Lockwasher (45)

- Engine stopped (see your -10)
- Carrier blocked (see your -10)
- Battery ground strap disconnected (WP 0337 00)
- Ramp lowered (see your -10)
- Rear floor plate removed (WP 0543 00)
- Rear bilge pump strainer removed (WP 0635 00)

Personnel Required

Unit Mechanic

REMOVAL

NOTE

Tag leads before removal.

1. Remove two screws (1), lockwashers (2), washers (3), and harness guard (4) from top of right fuel tank (5). Discard lockwashers.

REPLACE REAR MAIN WIRING HARNESS (M1064A3 ONLY) — Continued

0364 00

2. Disconnect circuit 23 and 24 leads (6), (7) from right tail light leads (8)(9).
3. Disconnect circuit 31 lead (10) from fuel transmitter lead (11) on right fuel tank (5).
4. Remove two screws (12), lockwashers (13), washers (14), and harness bracket (15) from top of right fuel tank (5). Discard lockwashers.
5. Remove screw (16), lockwasher (17), washer (18), and harness guard (19) from top of rear hull. Discard lockwasher.

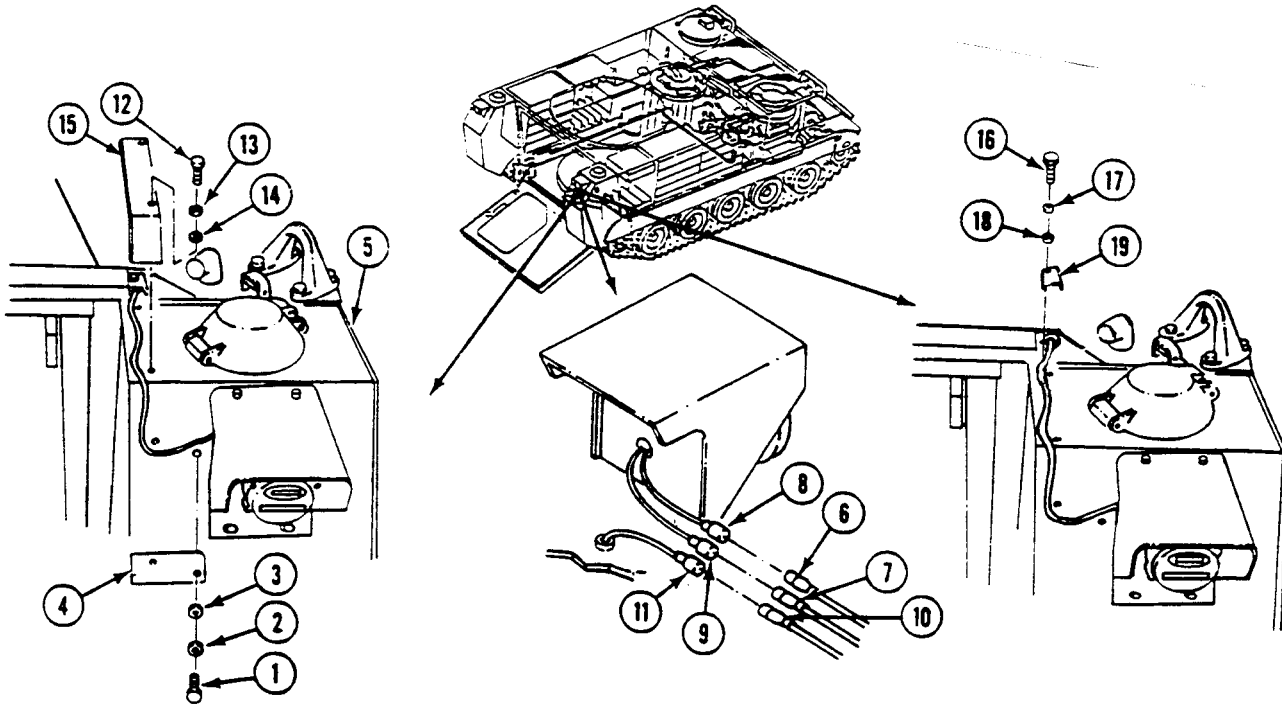

REPLACE REAR MAIN WIRING HARNESS (M1064A3 ONLY) — Continued

0364 00

6. Remove nut (1), washer (2), and rubber bushing (3) around harness (4) from connector (5).
7. Remove connector (5) from hull.
8. Pull harness (4) through hole in hull top. Leave connector (5), rubber bushing (3), washer (2), and nut (1) on harness.
9. Remove screw (6), locknut (7), clamp (8), and harness (4) from upper bilge tube clamp (9). Discard locknut.
10. Remove two screws (10), lockwashers (11), clamps (12), and harness (4) from two lower bilge tube clamps (13). Discard lockwashers.

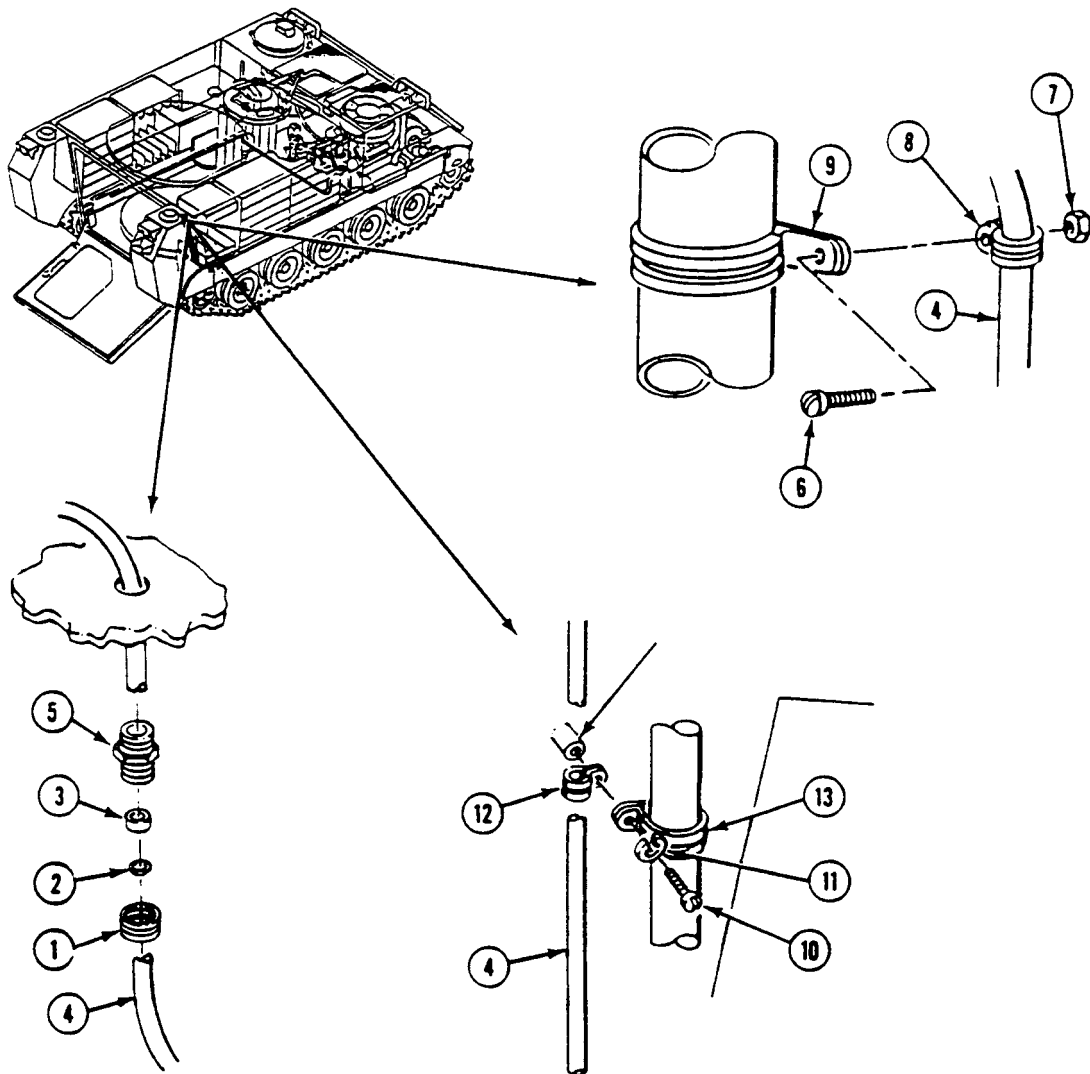

NOTE

Tag leads before removal.

11. Disconnect circuit 451 lead (1) from rear bilge pump (2).
12. Disconnect circuit 21 (3), 22 (4), 23 (5), and 24 (6) leads from trailer wiring harness leads (7)(8)(9)(10).
13. Remove two screws (11), locknuts (12), and clamp (13) from floor beam (14). Discard locknuts.
14. Remove screw (15), locknut (16), and clamp (13) from harness (17). Discard locknut.
15. Remove three screws (18), lockwashers (19), clamps (20), and harness (17) from weldnuts. Discard lockwashers.

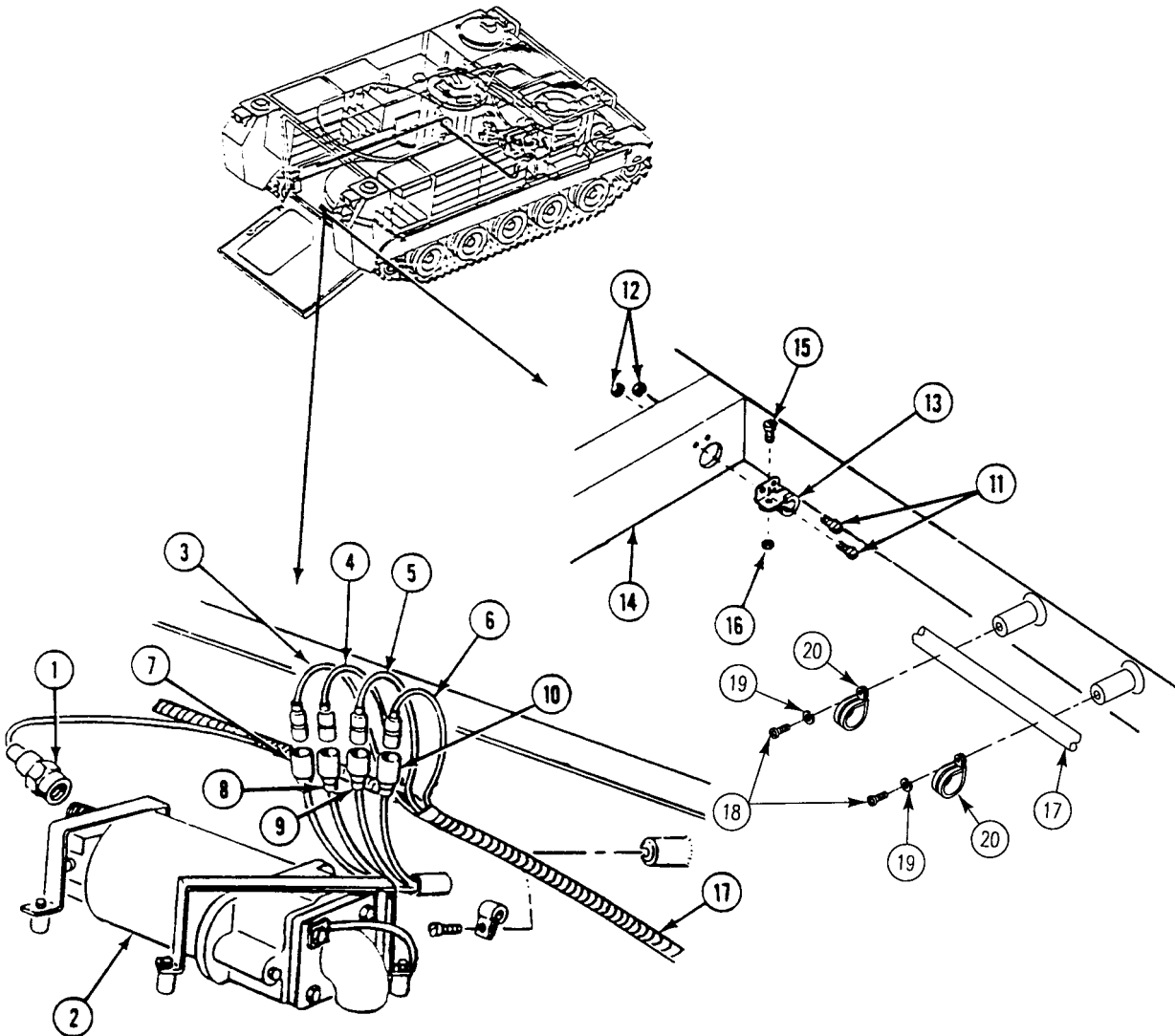

REPLACE REAR MAIN WIRING HARNESS (M1064A3 ONLY) — Continued

0364 00

16. Remove screw (1), lockwasher (2), clamp (3), and harness (4) from rear hull plate. Discard lockwasher.
17. Remove two screws (5), lockwashers (6), and guard (7) from two weldnuts (8) on rear hull plate. Discard lockwashers.
18. Remove two screws (9), locknuts (10), clamps (11), and harness (4) from guard (7). Discard locknuts.
19. Remove two screws (12), lockwashers (13), washers (14), and harness guard (15) from top of left fuel tank (16). Discard lockwashers.
20. Disconnect circuit 21 (17), 22 (18), and 24 (19) leads from left tail light leads (20)(21)(22).
21. Disconnect circuit 30 lead (23) from fuel transmitter lead (24) on left fuel tank (16).

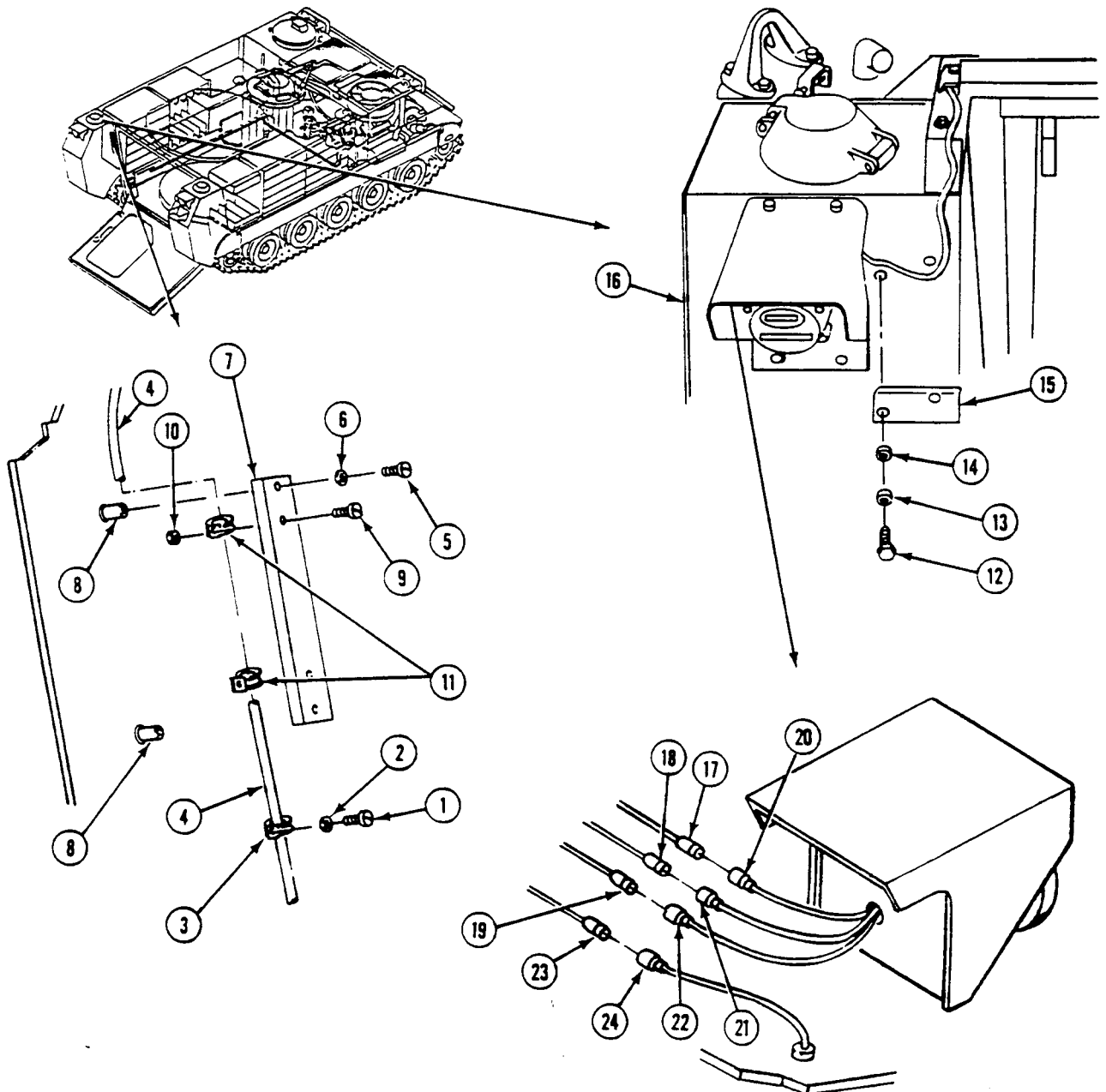

REPLACE REAR MAIN WIRING HARNESS (M1064A3 ONLY) — Continued

0364 00

22. Remove two screws (1), lockwashers (2), washers (3), and harness bracket (4) from top of left fuel tank (5). Discard lockwashers.
23. Remove screw (6), lockwasher (7), washer (8), and harness guard (9) from top of rear hull. Discard lockwasher.
24. Remove nut (10), washer (11), and rubber bushing (12) around harness (13) from connector (14).
25. Remove connector (14) from hull.
26. Pull harness (13) through hole in hull top. Leave connector (14), rubber bushing (12), washer (11), and nut (10) on harness (13).

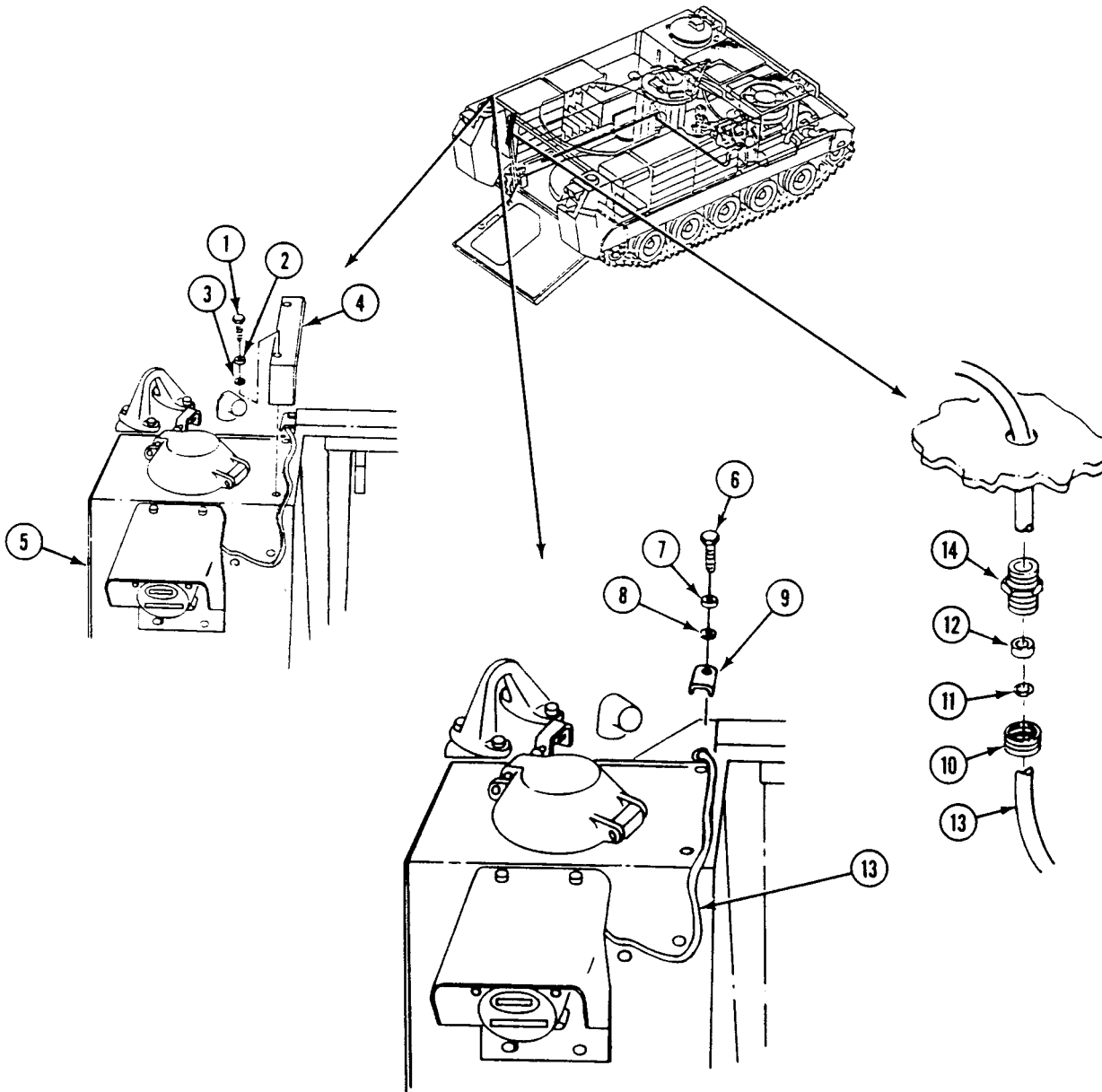

REPLACE REAR MAIN WIRING HARNESS (M1064A3 ONLY) — Continued

0364 00

27. Open top ammo rack (see your -10).
28. Remove nine screws (1), lockwashers (2), clamps (3), and harness (4) from weldnuts (5) on left hull plate. Discard lockwashers.
29. Remove screw (8), lockwasher (6), clamp (7), harness (4), ground lead (9), two lockwashers (10), and capacitor (11) from weldnut (12). Discard lockwashers.
30. Remove tape, screw (13), and circuit 48 lead (14) from capacitor (11).
31. Remove four screws (15), locknuts (16), and circuit 48 radio receptacle (17) from bracket (18). Discard locknuts.
32. Remove two screws (1), lockwashers (3), clamps (24) and circuit 48 lead (2) from weldnuts. Discard lockwashers.

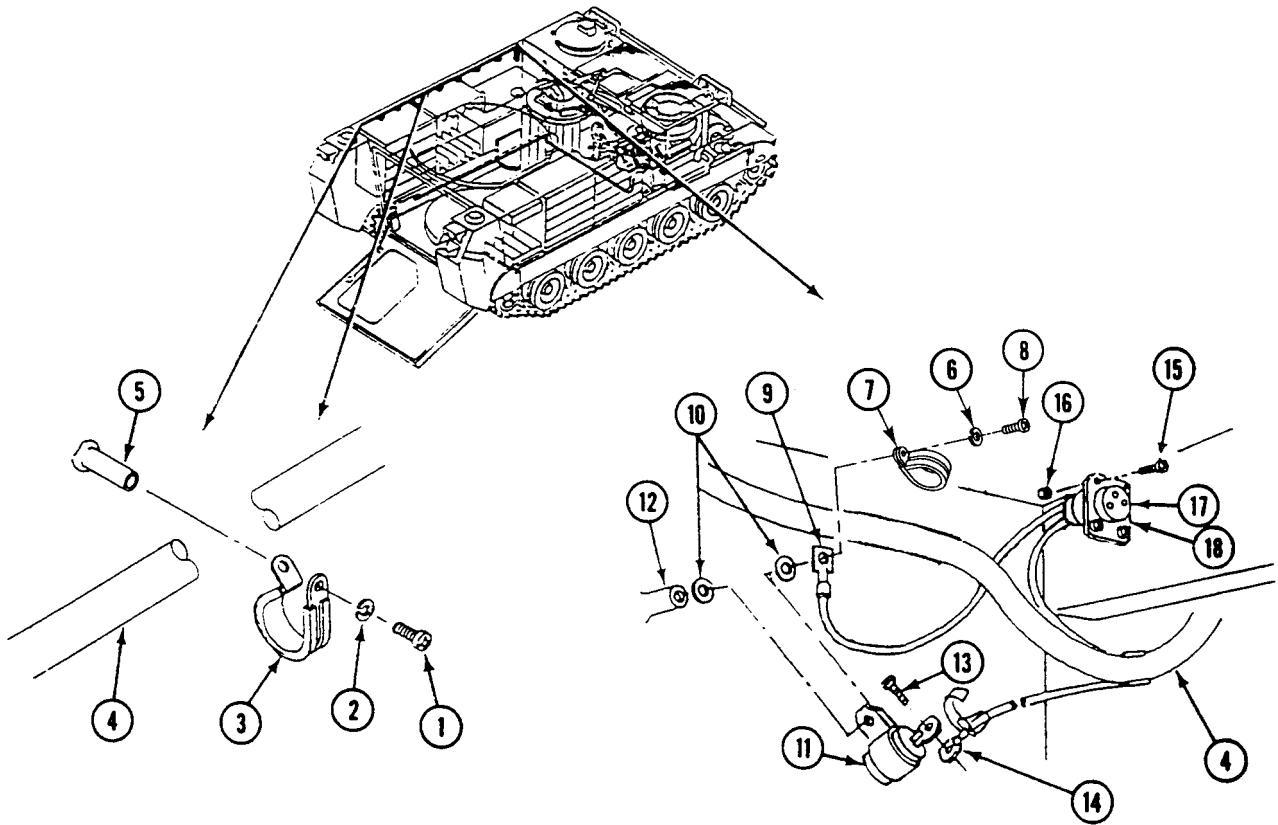

REPLACE REAR MAIN WIRING HARNESS (M1064A3 ONLY) — Continued

0364 00

33. Lower left crew seat backrest. Turn handle (4) clockwise and pull battery drawer (5) out.
34. Remove nut (6), screw (7), circuit 6 lead (8), circuit 6P lead (9), and circuit 48 lead (2) from battery terminal (10).
35. Remove circuit 48 lead (2) from grommet (11) in battery box (12). Discard grommet.
36. Remove two screws (13), lockwashers (15), four clamps (25), and circuit 48 lead (2) from weldnuts. Discard lockwashers.

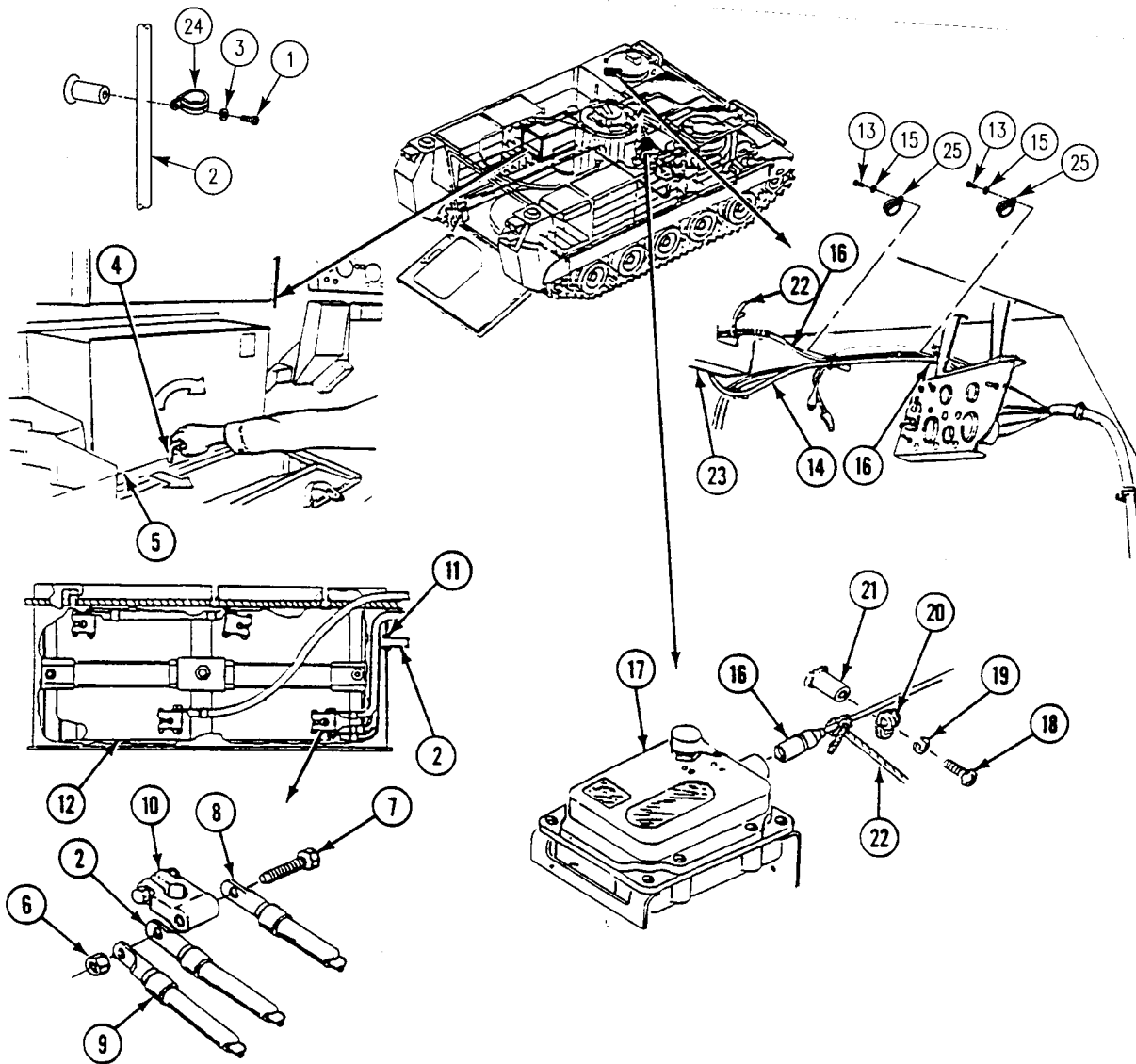

37. Disconnect circuit 38 lead (16) from dome light (17).

NOTE

If needed, remove personnel heater for access.

38. Remove three screws (18), lockwashers (19), clamps (20), and circuit 38 lead (16) from three weldnuts (21). Discard lockwashers.

39. Attach twine (22) to circuit 38 lead (16). Pull lead through transverse beam (23) into drivers compartment. Remove twine from lead and leave it in transverse beam.

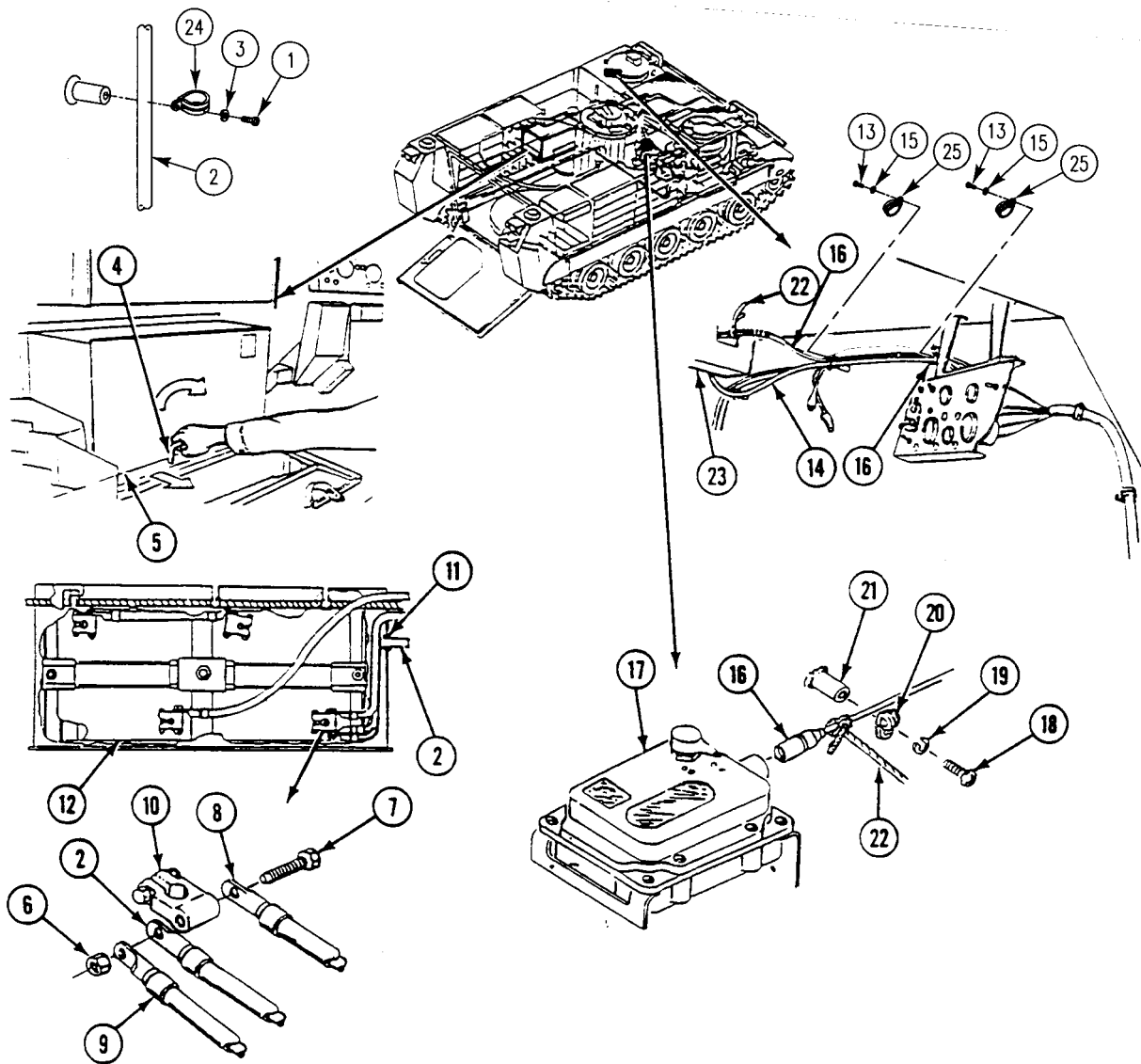

REPLACE REAR MAIN WIRING HARNESS (M1064A3 ONLY) — Continued

0364 00

40. If personnel heater is installed, disconnect circuit 400 lead (1) from heater control box lead.
41. If engine coolant heater is installed, disconnect circuit 400A lead (2) from engine coolant heater control box lead.
42. Remove screw (3), lockwasher (5), clamp (13), and harness (4) from weldnut. Discard lockwasher.
43. Remove two locknuts (6), mounts (7)(8), washers (9), and screws (10) that secure instrument panel (11) to two struts (12). Discard locknuts.
44. Support panel (11). Remove two screws (13), internal tooth lockwashers (14), and ground lead (15) from two panel mounts (16) and bracket (17). Discard lockwashers.
45. Lower panel (11) and support on two struts (12) to gain access to rear of instrument panel.

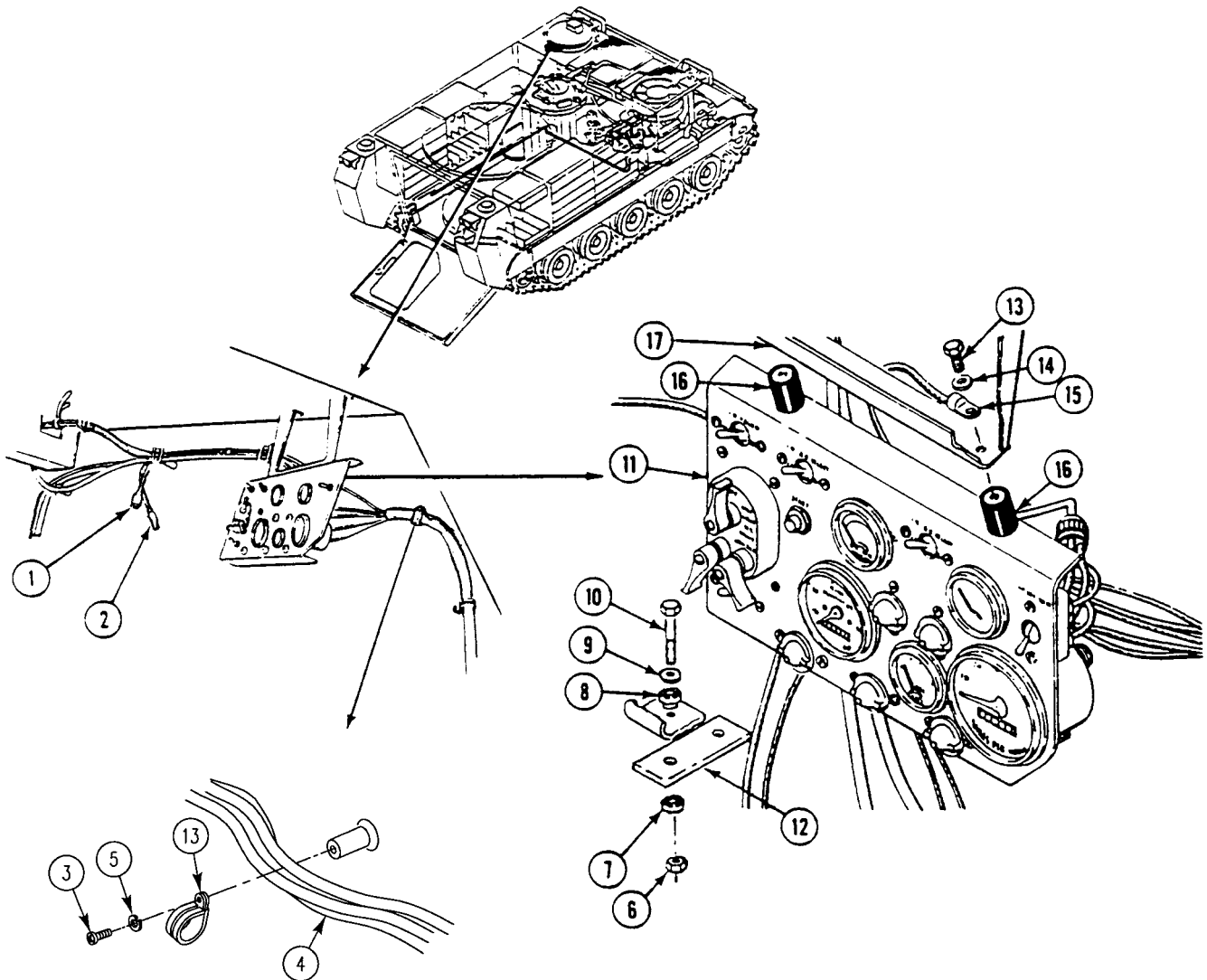

NOTE**Tag leads before removal.**

46. Disconnect circuit 30 (1) and 31 (2) leads from fuel gage switch (3).
47. Disconnect circuit 451B lead (4) from REAR BILGE PUMP ON indicator light (5).
48. Disconnect circuit 38 lead (6) from instrument panel wiring harness (7).
49. Disconnect circuit 450 (8), 450B (9), and 451A (10) leads from BILGE PUMPS switch leads (11)(12)(13).
50. Disconnect circuit 21 (14), 22 (15), 23 (16), and 24 (17) leads from front main wiring harness (18).

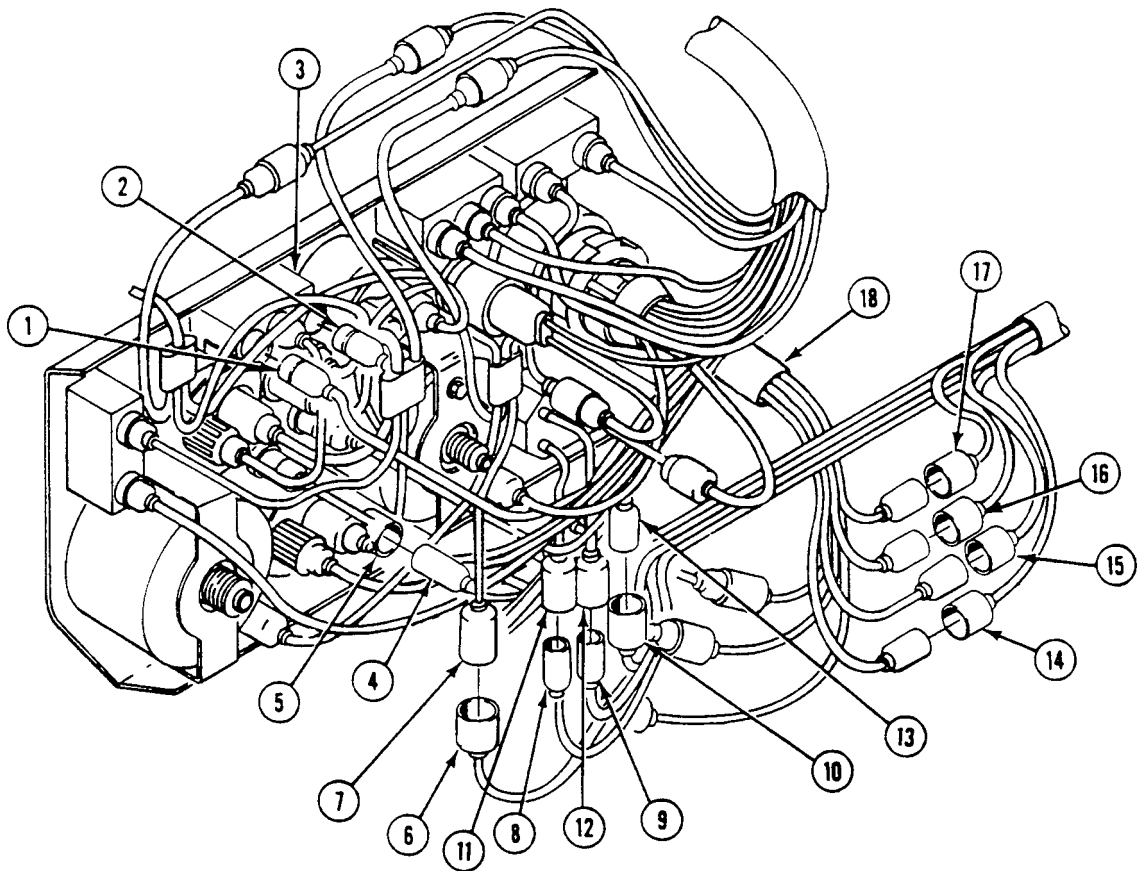

REPLACE REAR MAIN WIRING HARNESS (M1064A3 ONLY) — Continued

0364 00

51. Disconnect circuit 37 lead (1) from master switch panel lead (2).
52. Remove eight screws (3), washers (4), and locknuts (5) from master switch panel (6). Separate panel (6) from distribution box (7). Discard locknuts.
53. Remove locknut (8), screw (9), and circuit 400 (10), circuit 2 (11), and circuit 6 (12) leads from bus bar (13) on MASTER SWITCH (14). Discard locknut.
54. Remove circuit 400 lead (10) and grommet (15) from distribution box (7). Discard grommet.
55. Disconnect circuit 450 lead (16) from lower circuit breaker (17).
56. Disconnect circuit 450B lead (18) from upper circuit breaker (19).
57. Remove circuit 450 (16) and 450B (18) leads and two grommets (20) from distribution box (7). Discard grommets.
58. Remove harness from carrier.

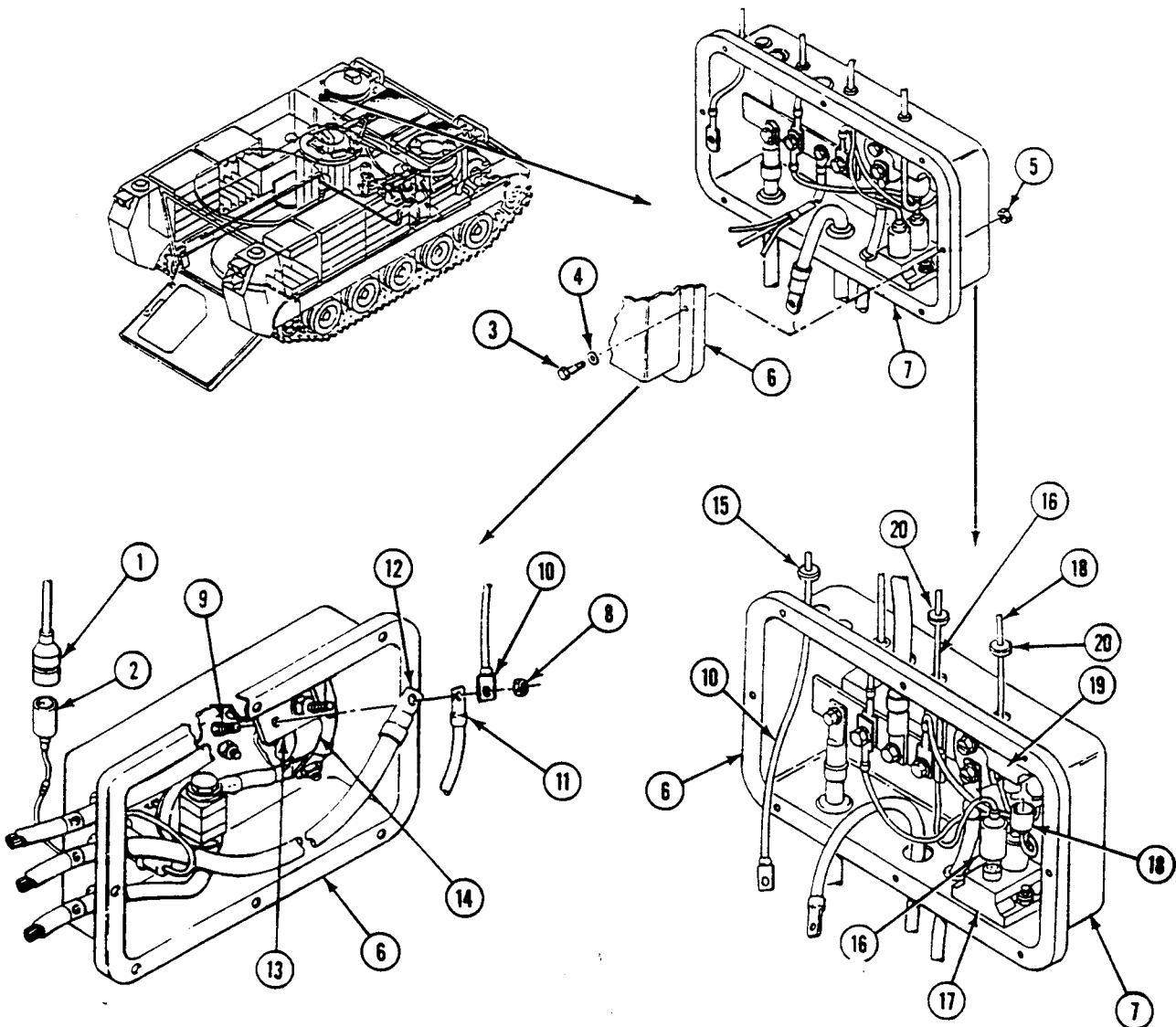

INSPECTION-ACCEPTANCE AND REJECTION CRITERIA

INSPECTION AND REPAIR

1. Inspect for damaged connectors and terminals. Repair as needed (WP 0382 00).

INSTALLATION

1. Install harness in carrier.
2. Install circuit 450 (1) and 450B (2) leads and two new grommets (3) in distribution box (4).
3. Connect circuit 450B lead (2) to upper circuit breaker (5).

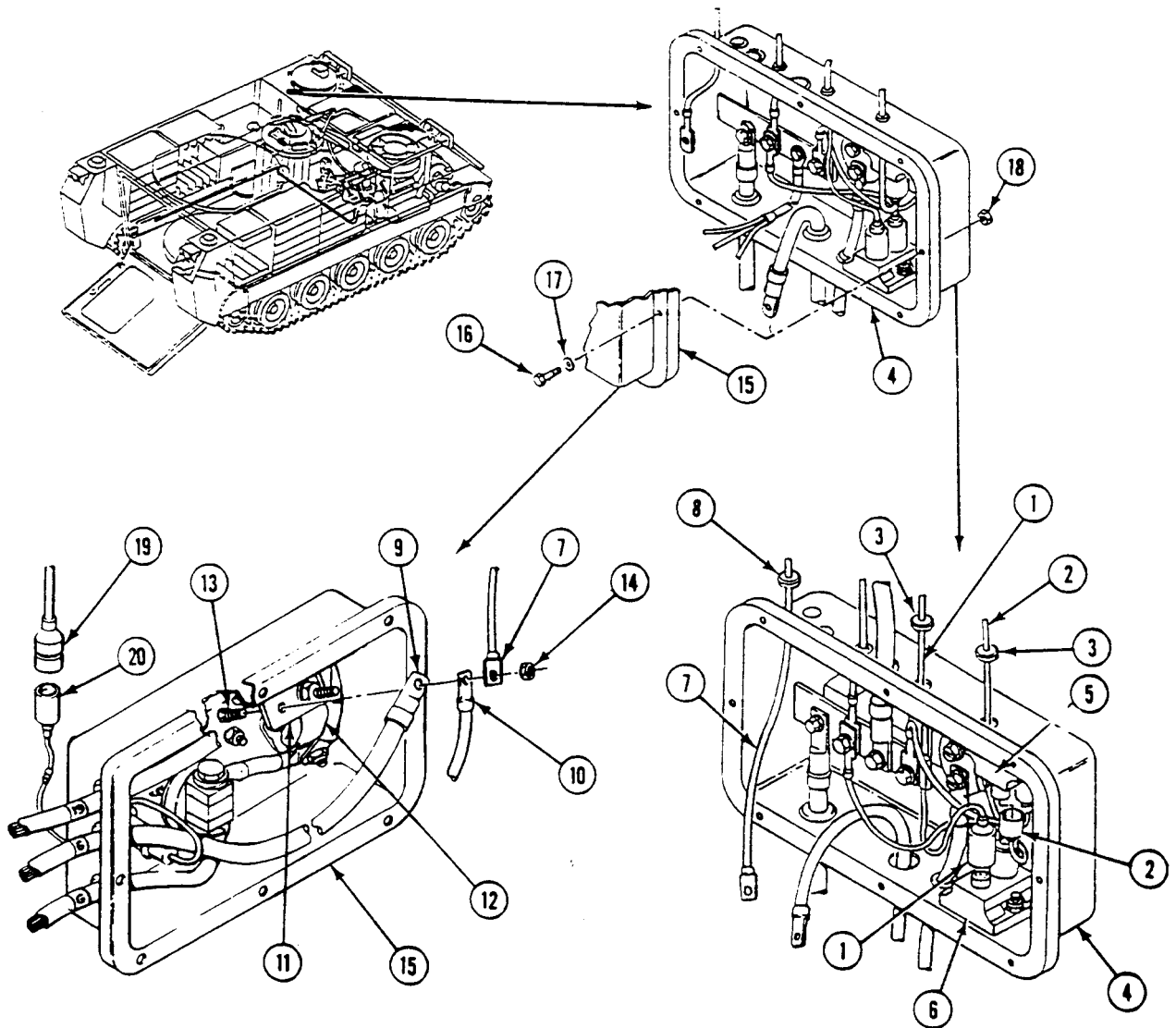

4. Connect circuit 450 lead (1) to lower circuit breaker (6).
5. Install circuit 400 lead (7) and new grommet (8) in distribution box (4).
6. Install circuit 6 (9), circuit 2 (10), and circuit 400 (7) leads on bus bar (11) on MASTER SWITCH (12). Secure with screw (13) and new locknut (14).

NOTE

Inspect gasket on distribution box. Replace if damaged.

7. Install master switch panel (15) on distribution box (4). Secure with eight screws (16), washers (17), and new locknuts (18).
8. Connect circuit 37 lead (19) to master switch panel lead (20).

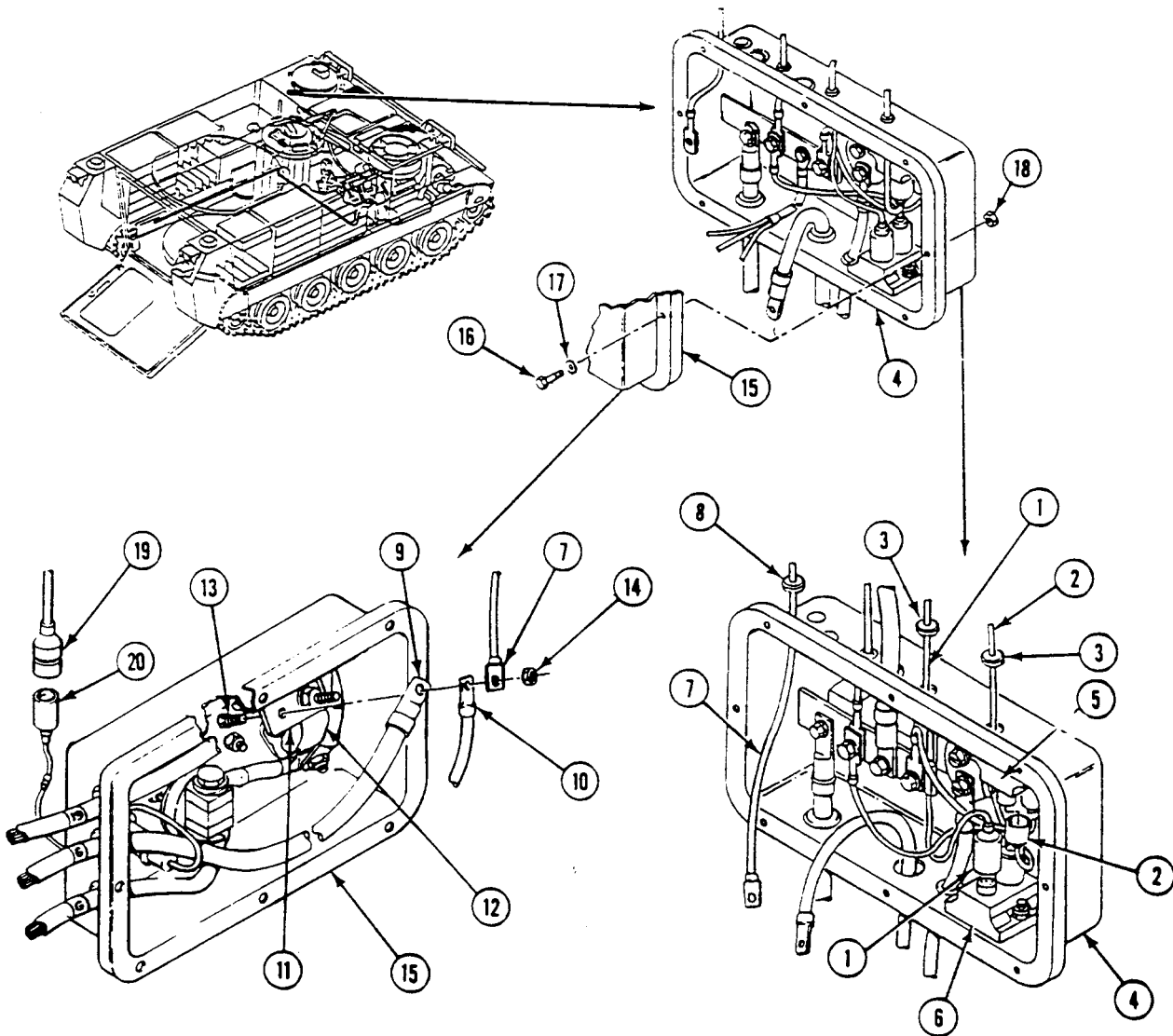

REPLACE REAR MAIN WIRING HARNESS (M1064A3 ONLY) — Continued

0364 00

9. Connect circuit 21 (1), 22 (2), 23 (3), and 24 (4) leads to front main wiring harness (5).
10. Connect circuit 450 (6), 450B (7), and 451A (8) leads to BILGE PUMPS switch leads (9)(10)(11).
11. Connect circuit 38 lead (12) to instrument panel wiring harness (13).
12. Connect circuit 451B lead (14) to REAR BILGE PUMP ON indicator light (15).
13. Connect circuit 30 (16) and 31 (17) leads to fuel gauge switch (18).

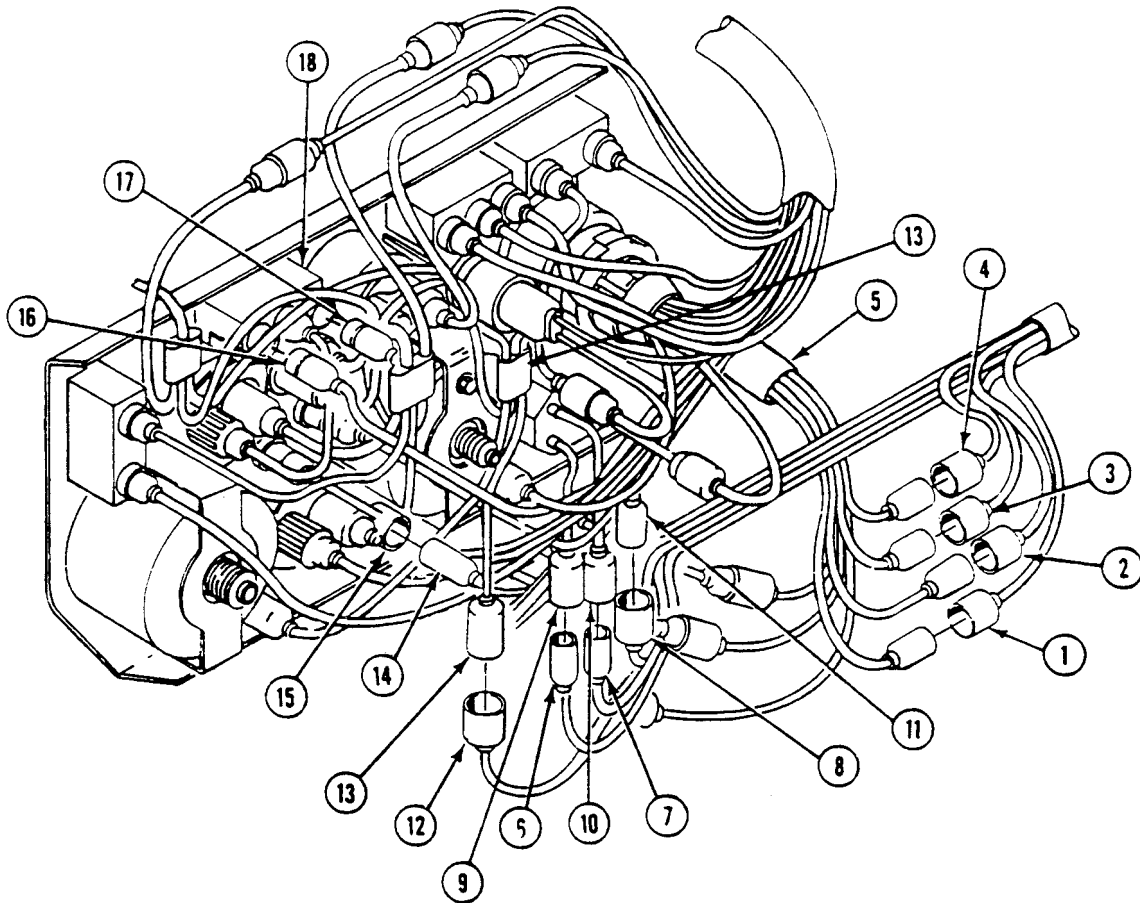

REPLACE REAR MAIN WIRING HARNESS (M1064A3 ONLY) — Continued

0364 00

14. Position ground lead (1) at forward hole of bracket (2). Secure instrument panel (3) to bracket (2) with two panel mounts (4), screws (5) and new internal tooth lockwasher (6).
15. Secure panel (3) to two struts (7) with two mounts (8)(9), screws (10), washers (11), and new locknuts (12).
16. Secure harness (13) to weldnut with clamp (14), screw (15), and new lockwasher (18).
17. If engine coolant heater is installed, connect circuit 400A lead (16) to engine coolant heater control box lead.
18. If personnel heater is installed, connect circuit 400 lead (17) to heater control box lead.

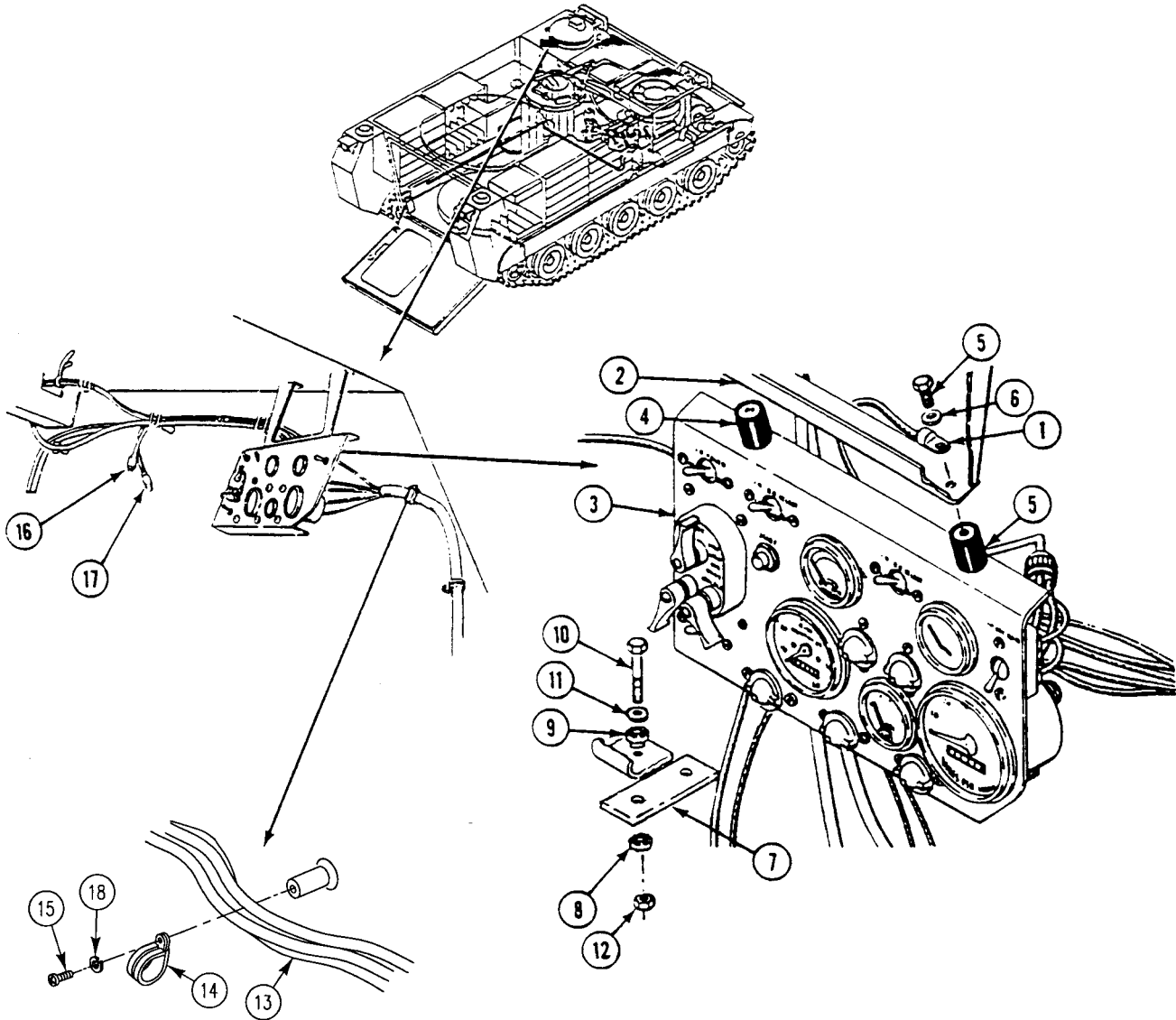

REPLACE REAR MAIN WIRING HARNESS (M1064A3 ONLY) — Continued

0364 00

19. Attach twine (1) that was left in transverse beam (2) to circuit 38 lead (3). Pull lead through transverse beam (2) into personnel compartment. Remove twine from lead.
20. Secure circuit 38 lead (3) to three weldnuts (4) on transverse beam with three clamps (5), screws (6), and new lockwashers (7).
21. Connect circuit 38 lead (3) to dome light (8).

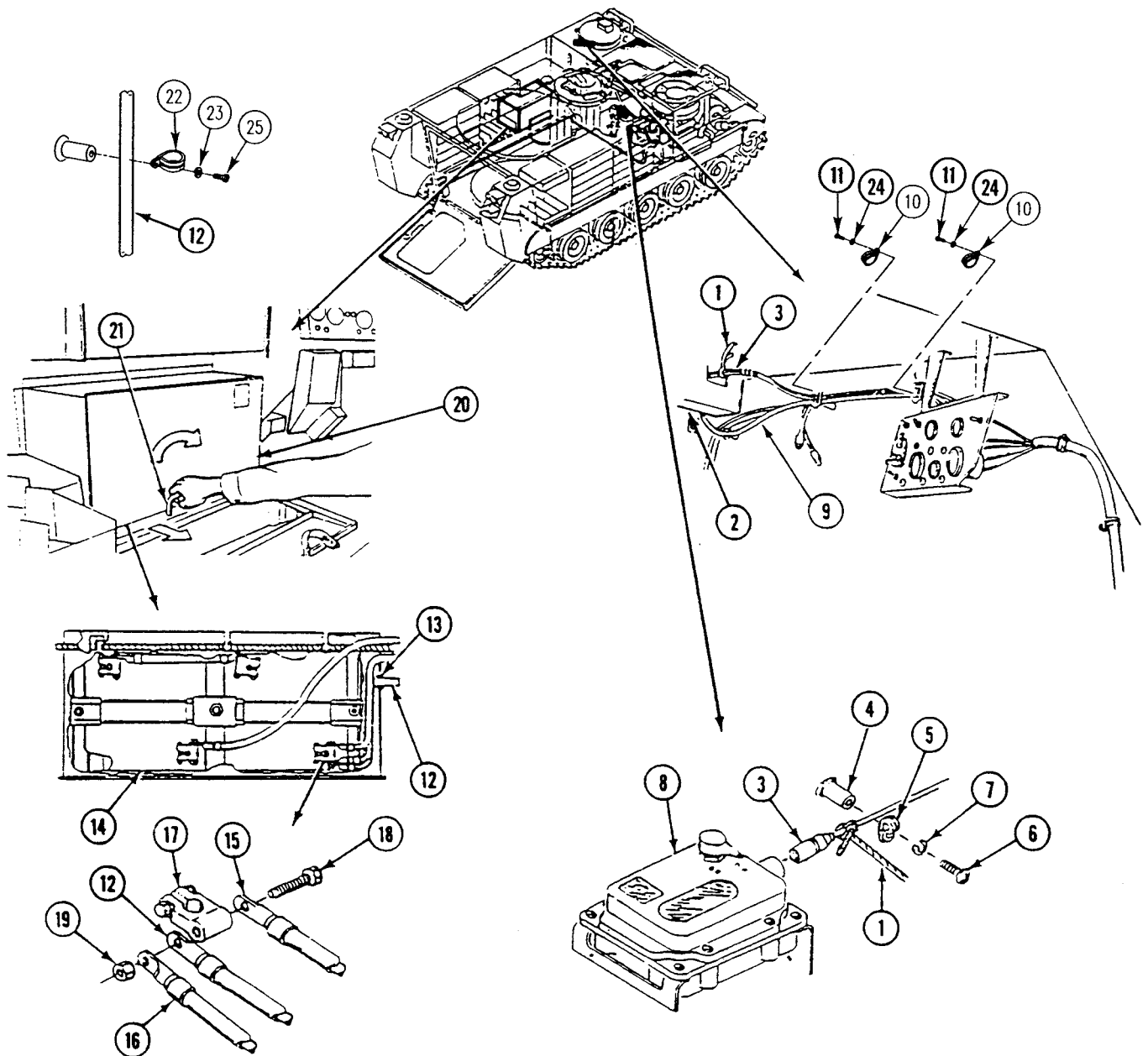

REPLACE REAR MAIN WIRING HARNESS (M1064A3 ONLY) — Continued

0364 00

22. Install harness (9) in four clamps (10). Secure with two screws (11) and new lockwashers (24).
23. Install circuit 48 lead (12) and new grommet (13) in battery box (14).
24. Install circuit 6 lead (15), circuit 6P lead (16), and circuit 48 lead (12) on battery terminal (17). Secure with screw (18) and nut (19).
25. Push battery drawer (20) in and turn handle (21) counterclockwise to lock drawer. Raise left crew seat backrest.
26. Install circuit 48 lead (12) in two clamps (22). Secure with two new lockwashers (23) and screws (25).

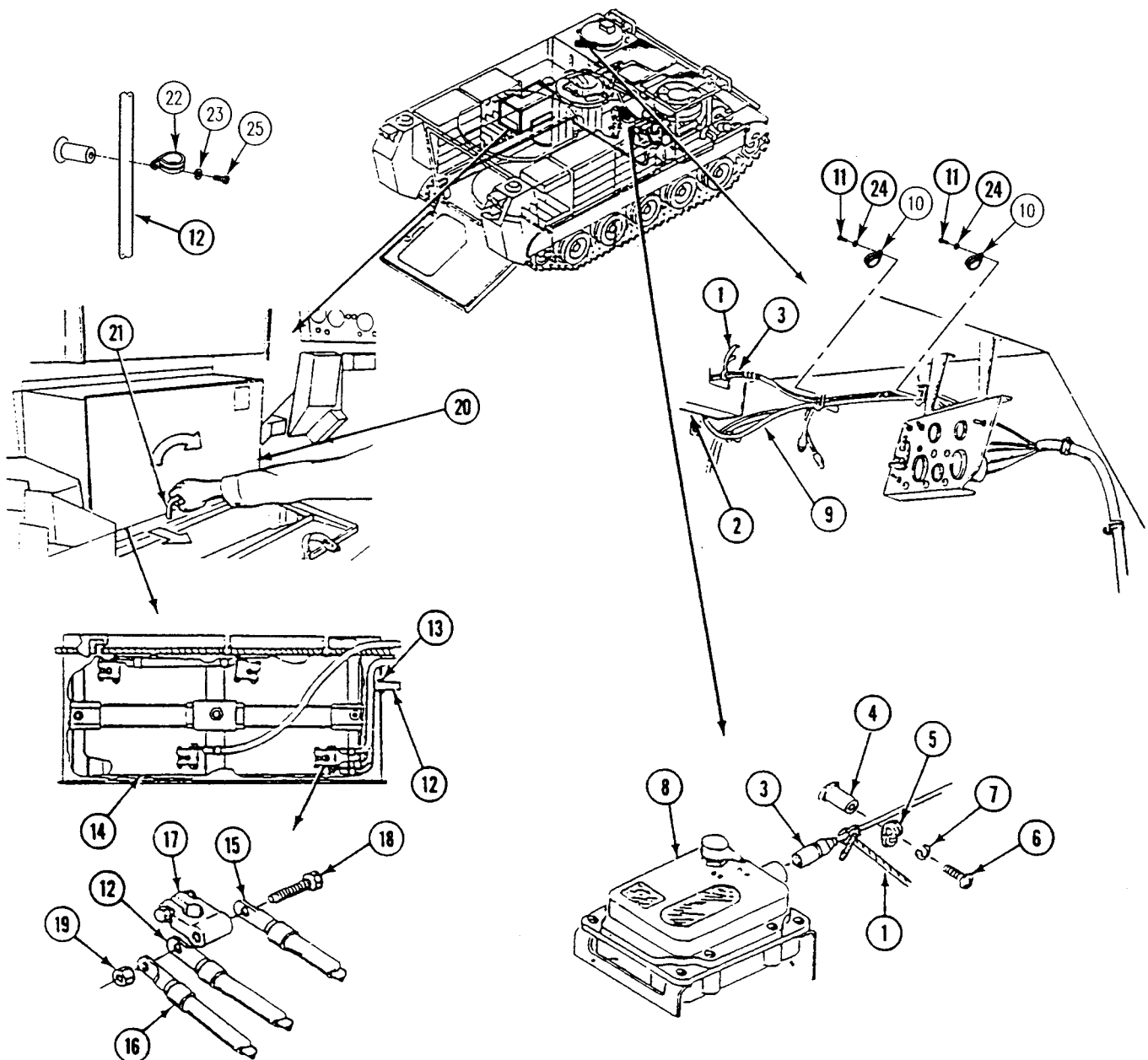

REPLACE REAR MAIN WIRING HARNESS (M1064A3 ONLY) — Continued

0364 00

27. Install circuit 48 radio receptacle (1) on bracket (2). Secure with four screws (3) and new locknuts (4).
28. Connect circuit 48 lead (5) to capacitor (6). Secure with screw (7) and tape.
29. Install capacitor (6), ground lead (8), clamp (9), and two new lockwashers (11) on weldnut (10).
30. Install harness (13) in clamp (9). Secure with new lockwasher (14) and screw (12).
31. Secure harness (13) to weldnuts (15) on left hull plate with nine clamps (16), screws (17), and new lockwashers (18).

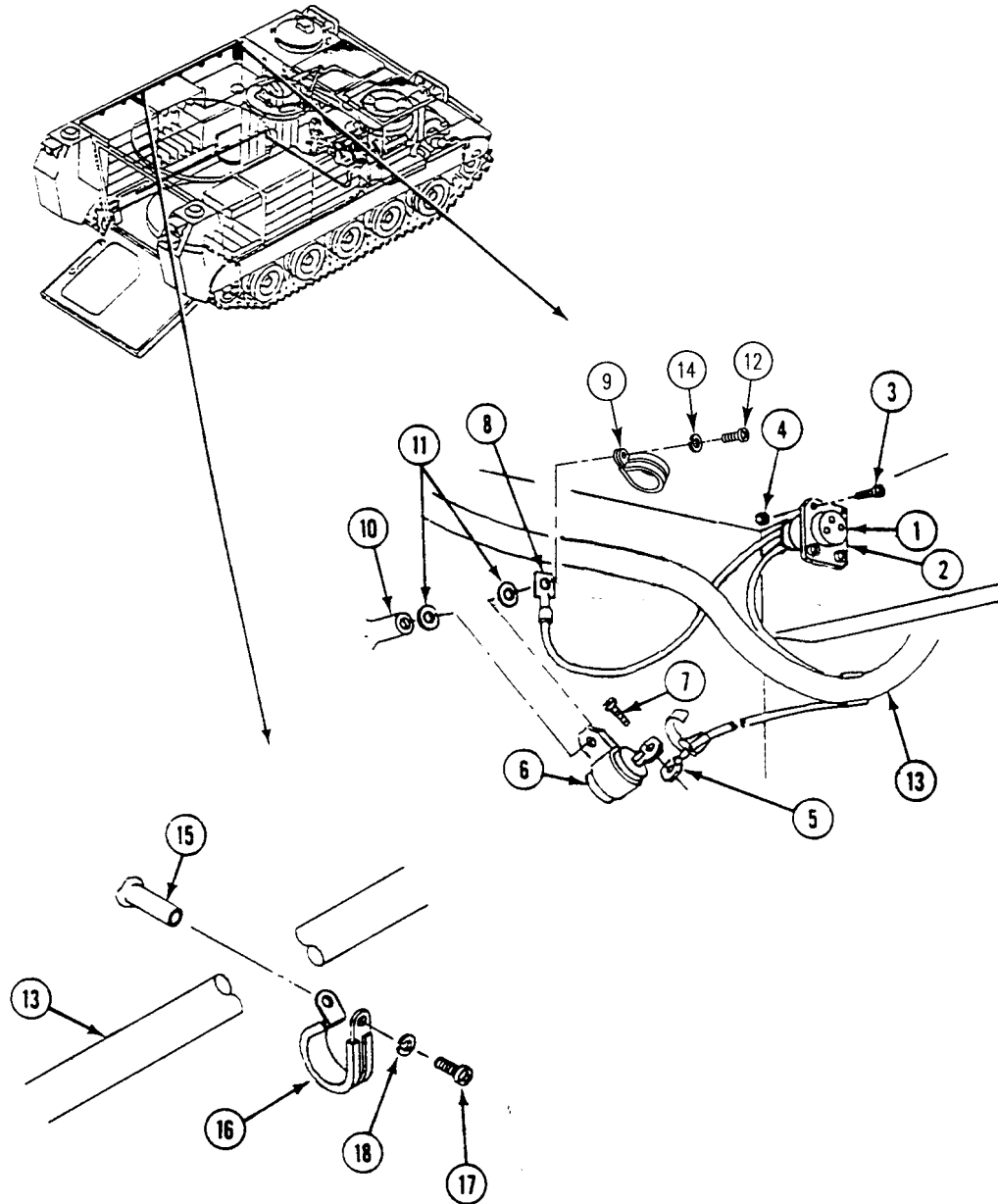

REPLACE REAR MAIN WIRING HARNESS (M1064A3 ONLY) — Continued

0364 00

32. Close top ammo rack (see your -10).
33. Insert harness left side branch (1) through hole in hull top.
34. Install connector (2) in hull.
35. Secure harness (1) in connector (2) with rubber bushing (3), washer (4), and nut (5).
36. Insert harness (1) through hole in rear plate (6).
37. Install harness guard (7) on top of rear hull. Secure with screw (8), washer (9), and new lockwasher (10).
38. Route harness (1) along top of left fuel tank (11) and install harness bracket (12) over harness (1). Secure with two screws (13), washers (14), and new lockwashers (15).

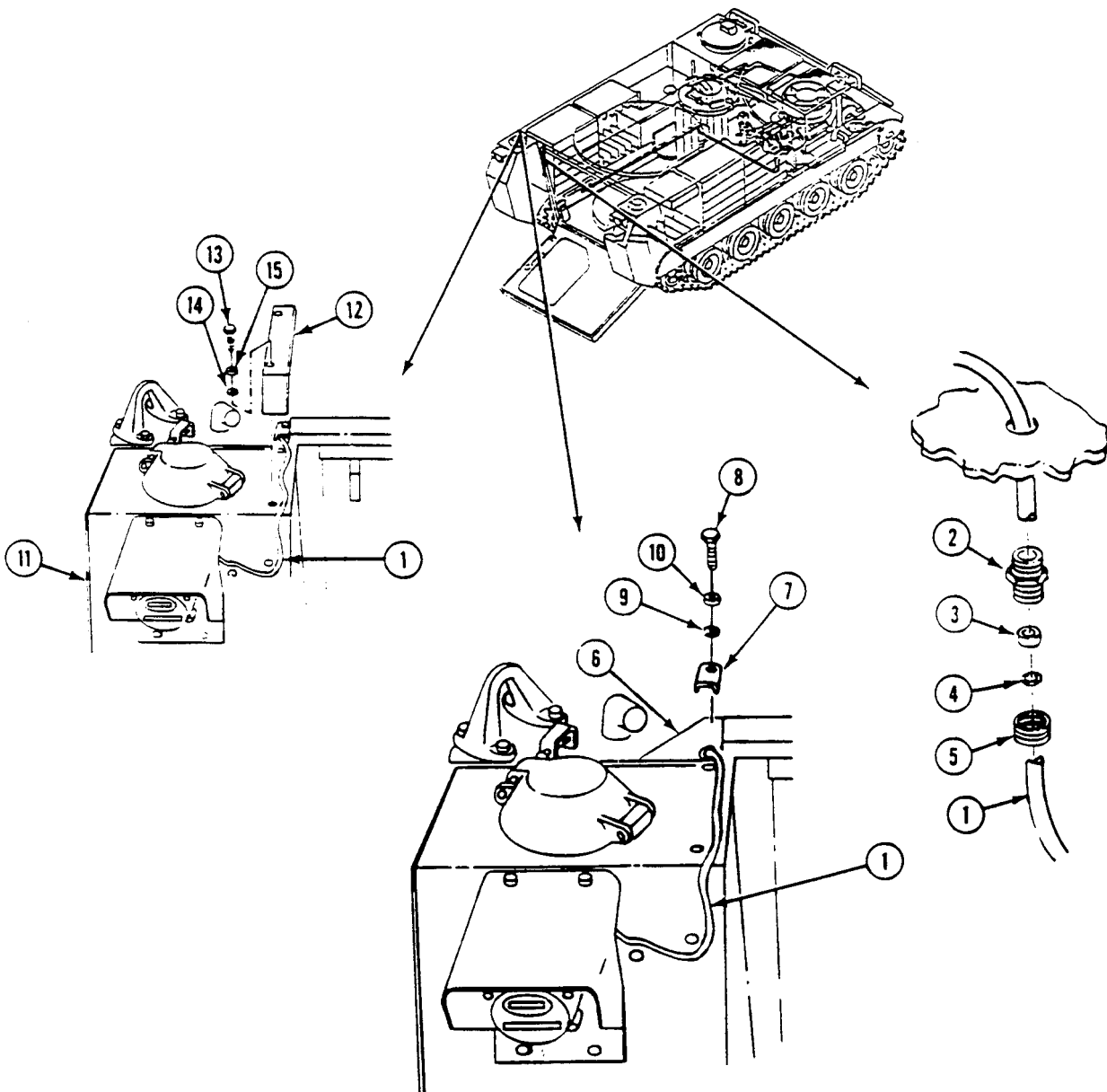

REPLACE REAR MAIN WIRING HARNESS (M1064A3 ONLY) — Continued

0364 00

39. Connect circuit 30 lead (1) to fuel transmitter lead (2) on left fuel tank (3).
40. Connect circuit 21 (4), 22 (5), and 24 (6) leads to left tail light leads (7)(8)(9).
41. Install harness guard (10) over harness (11) on left fuel tank (3). Secure with two screws (12), washers (13), and new lockwashers (14).
42. Secure harness (11) to guard (15) with two clamps (16), screws (17), and new locknuts (18).
43. Install guard (15) on two weldnuts (19) on rear hull plate. Secure with two screws (20) and new lockwashers (21).
44. Secure harness (11) on rear hull plate with clamp (22), screw (23), and new lockwasher (24).

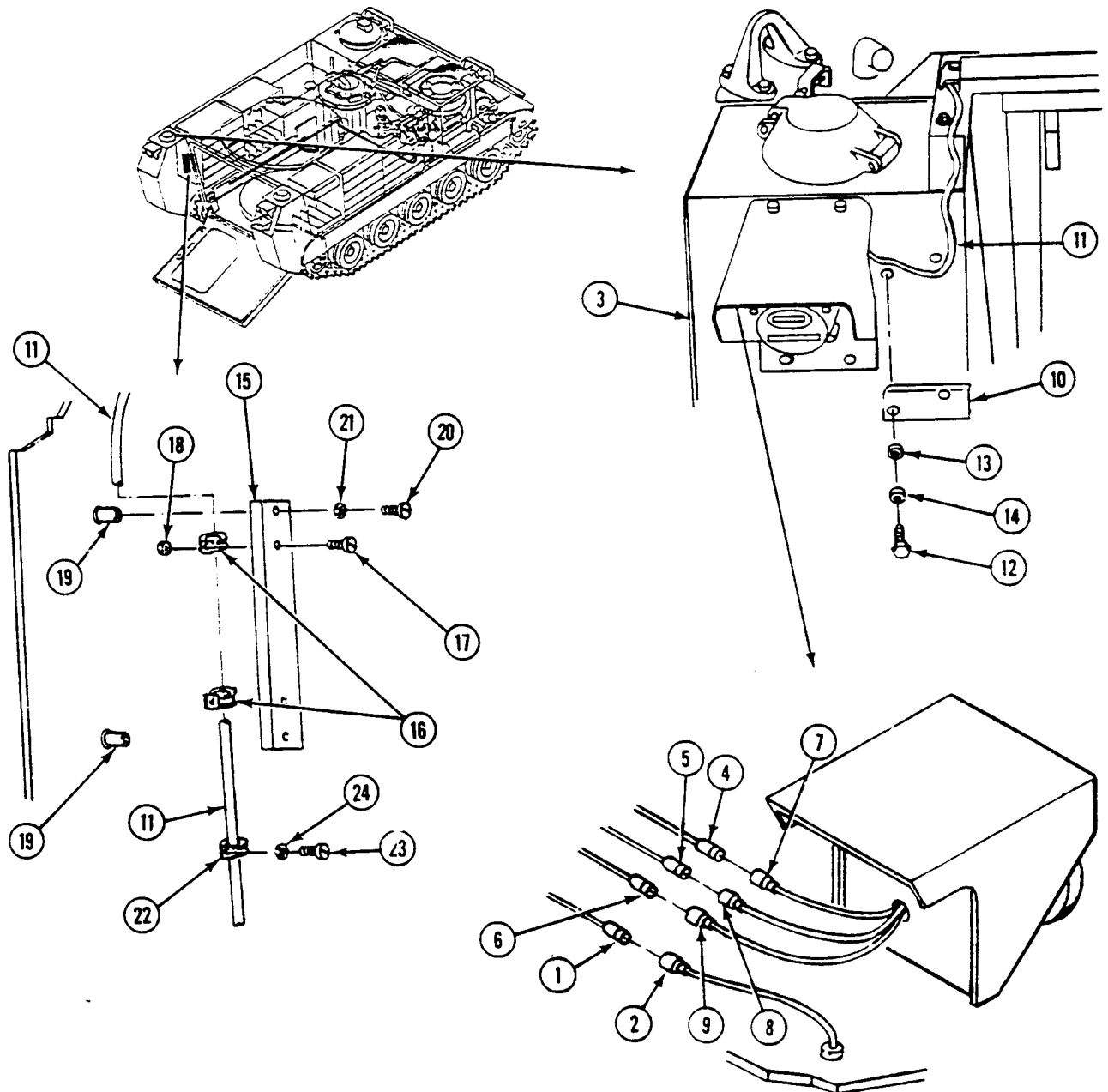

REPLACE REAR MAIN WIRING HARNESS (M1064A3 ONLY) — Continued

0364 00

45. Install harness (1) in three clamps (2). Secure with three new lockwashers (3) and screws (20).
46. Install clamp (4) on harness (1) with screw (5) and new locknut (6).
47. Secure clamp (4) to floor beam (7) with two screws (8) and new locknuts (9).
48. Connect circuit 21 (10), 22 (11), 23 (12), and 24 (13) leads to four trailer wiring harness leads (14)(15)(16)(17).
49. Connect circuit 451 lead (18) to rear bilge pump (19).

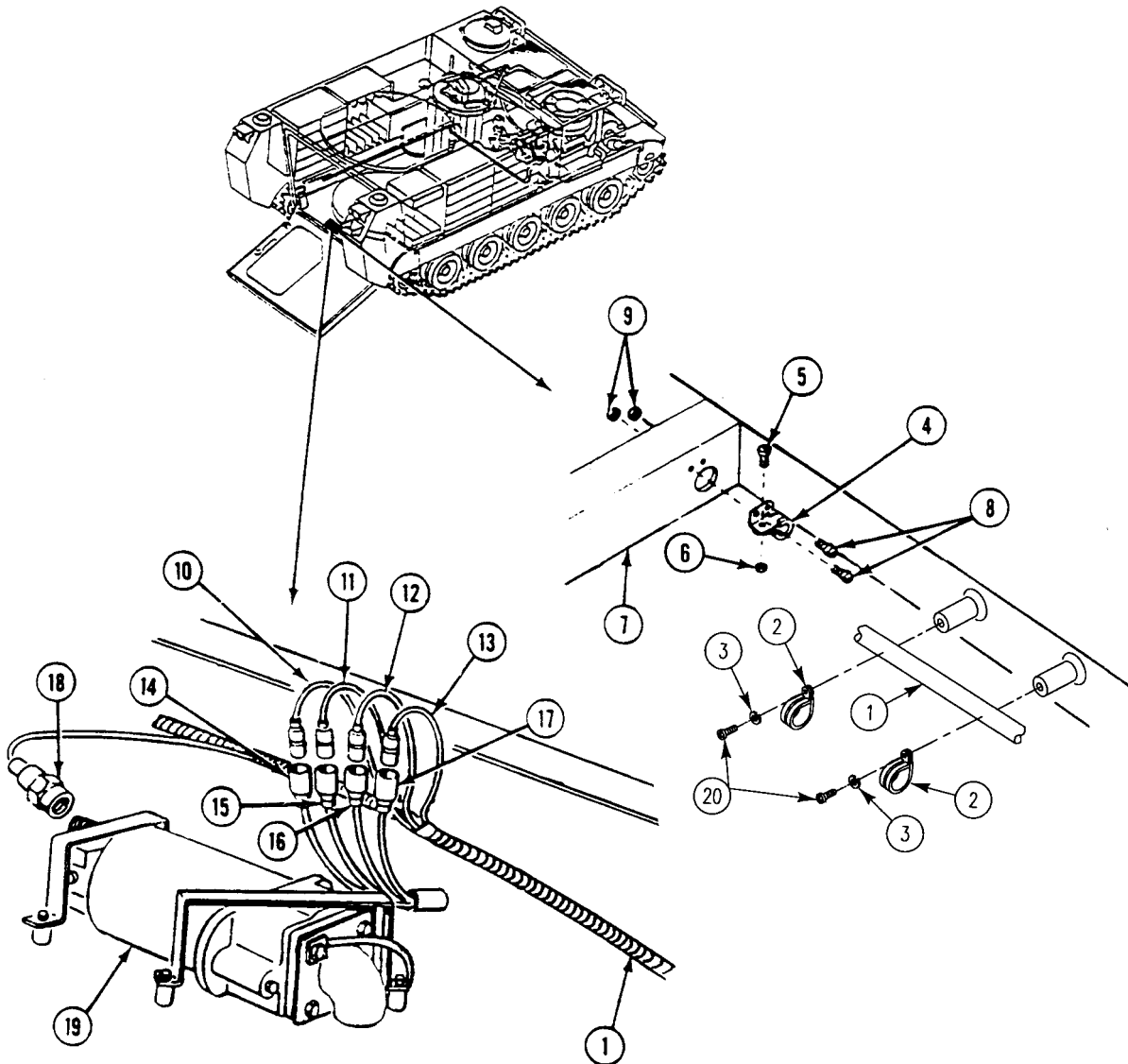

REPLACE REAR MAIN WIRING HARNESS (M1064A3 ONLY) — Continued

0364 00

50. Secure harness (1) to two lower bilge tube clamps (2) with two clamps (3), screws (4), and new lockwashers (5).
51. Secure harness (1) to upper bilge tube clamp (6) with clamp (7), screw (8), and new locknut (9).
52. Insert harness right side branch (1) through hole in hull top.
53. Install connector (10) in hull.
54. Secure harness (1) in connector (10) with rubber bushing (11), washer (12), and nut (13).

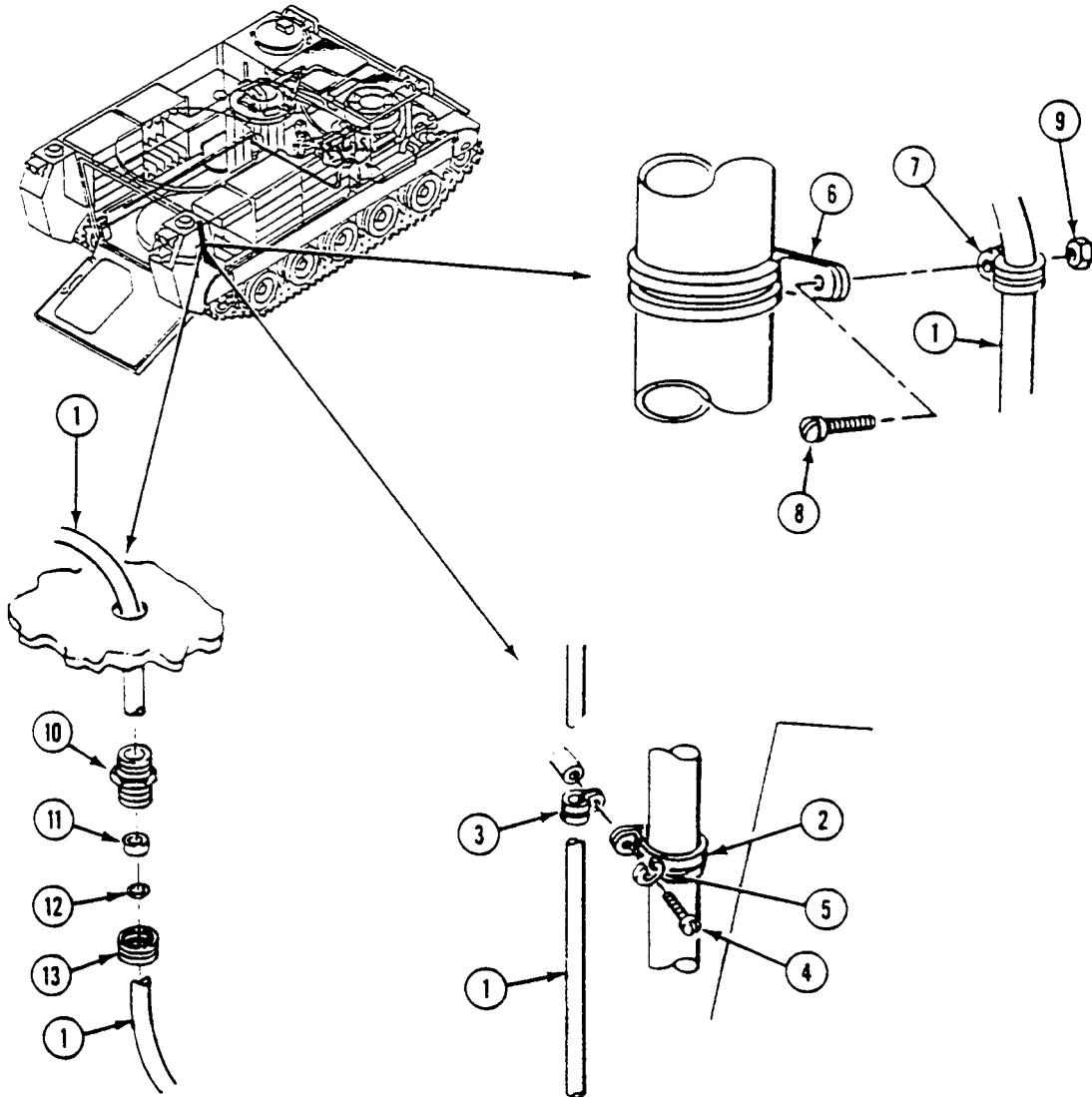

REPLACE REAR MAIN WIRING HARNESS (M1064A3 ONLY) — Continued

0364 00

55. Insert harness (1) through hole in rear plate (2).
56. Install harness guard (3) on top of rear hull. Secure with screw (4), washer (5), and new lockwasher (6).
57. Route harness (1) along top of right fuel tank (7) and install harness bracket (8) over harness (1). Secure with two screws (9), washers (10), and new lockwashers (11).
58. Connect circuit 31 lead (12) to fuel transmitter lead (13) on right fuel tank (7).
59. Connect circuit 23 (14) and 24 (15) leads to right tail light leads (16)(17).
60. Install harness guard (18) over harness (1) on right fuel tank (7). Secure with two screws (19), washers (20), and new lockwashers (21).

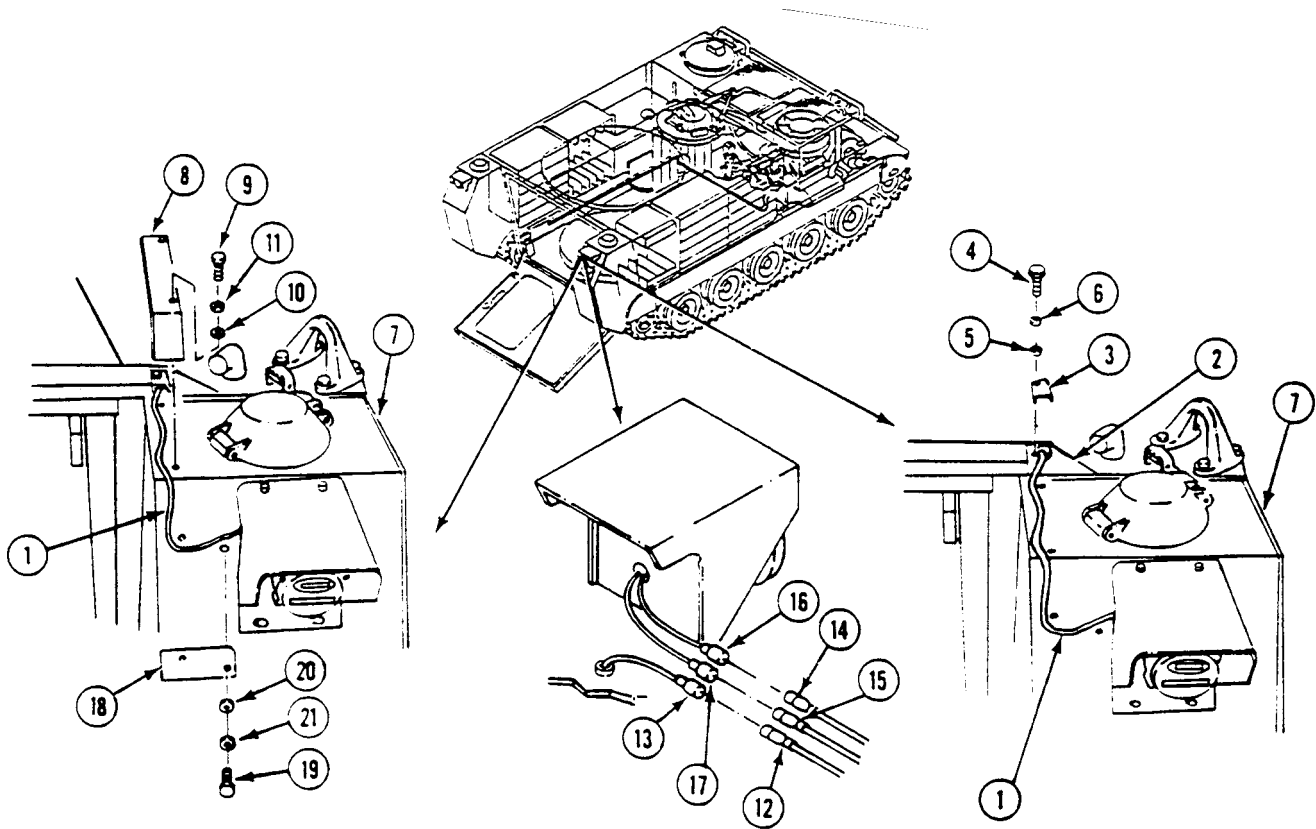

FOLLOW-THROUGH STEPS

1. Install rear bilge pump strainer (WP 0635 00).
2. Install rear floor plate (WP 0543 00).
3. Connect battery ground strap (WP 0337 00).
4. Turn MASTER SWITCH to ON and start engine (see your -10).
5. Check that electrical system works properly (see your -10).
6. Raise and lock ramp (see your -10).
7. Stop engine (see your -10).

END OF TASK

REPLACE REAR MAIN WIRING HARNESS (M1068A3 ONLY)

0365 00

THIS WORK PACKAGE COVERS:

- Removal (page 0365 00-2).
- Inspect and Repair (page 0365 00-16).
- Installation (page 0365 00-17).

INITIAL SETUP:

Maintenance Level

Unit

Tools and Special Tools

General Mechanic's Tool Kit (WP 0926 00, Item 65)

Materials/Parts

- Nonelectrical wire (WP 0928 00, Item 42)
- Gasket
- Grommet (10)
- Locknut (35)
- Lockwasher (26)

Personnel Required

Unit Mechanic

References

- See your -10
- TM 11-7010-256-12&P

Equipment Condition

- Engine stopped (see your -10)
 - Carrier blocked (see your -10)
 - Ramp lowered (see your -10)
 - Battery access cover removed (see your -10)
 - Battery ground lead disconnected (WP 0338 00)
 - Rear floor plate removed (WP 0544 00)
-

REMOVAL

1. Disconnect circuit 29 lead (1) from right fuel quantity sending unit (2).
2. Remove lockwire (3), screw (4), lockwasher (5), and ground lead (6) from sending unit (2). Discard lockwire and lockwasher.
3. Remove four screws (7), two lockwashers (8), flat washer (9), ground lead (6), and clamps (10) from weldnuts (11). Remove clamps from circuit 29 lead (1). Discard lockwashers.
4. Disconnect circuit 23 lead (12) and circuit 24 lead (13) from right tail light (14).
5. If NBC unit is installed, disconnect circuit 415 lead (15) from NBC unit switch.
6. Disconnect circuit 37A lead (16) from right utility outlet lead (17).

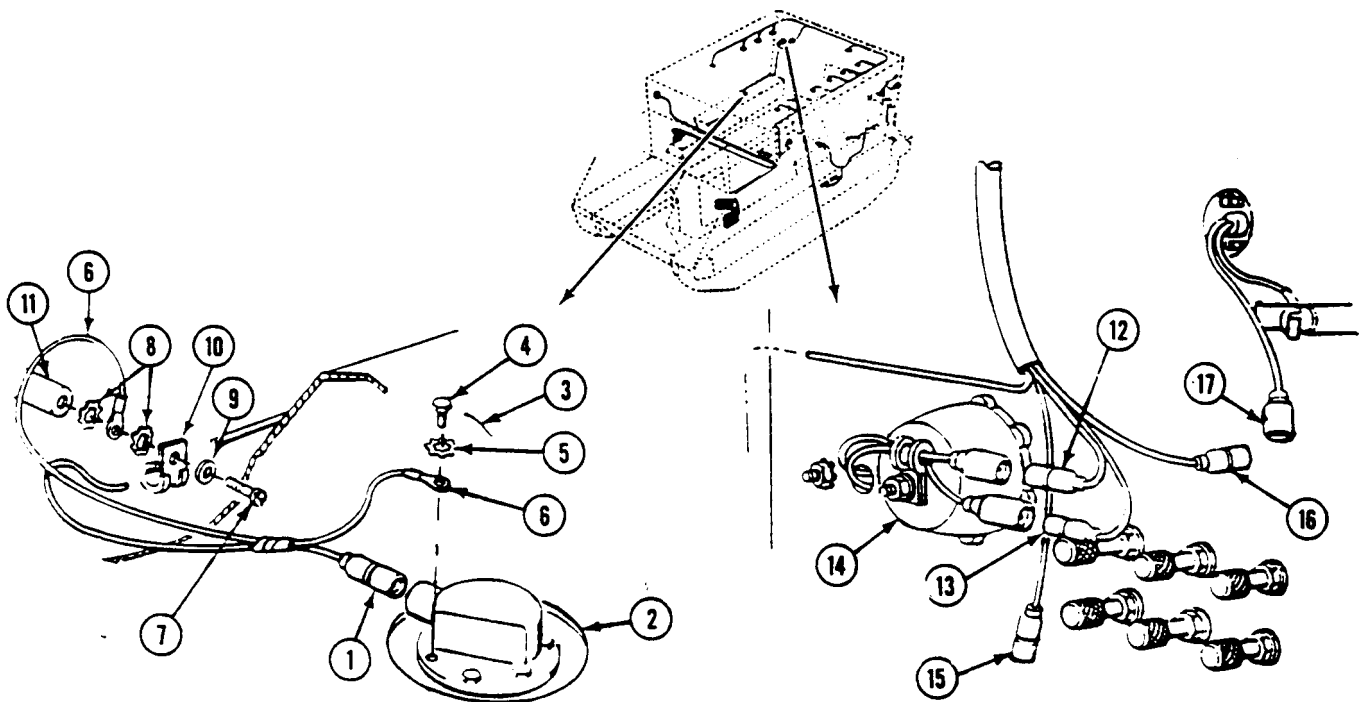

REPLACE REAR MAIN WIRING HARNESS (M1068A3 ONLY) — Continued

0365 00

7. Remove three screws (1), lockwashers (3), six clamps (25), and rear main wiring harness (2) from weldnuts. Discard lockwashers.
8. Disconnect four circuit 38C leads (4) from four right side dome lights (5).
9. Remove six screws (6), lockwashers (7), clamps (26) and rear main wiring harness (2) from weldnuts. Discard lockwashers.
10. Disconnect circuit 38B lead (8) from rear blackout dome light (9).

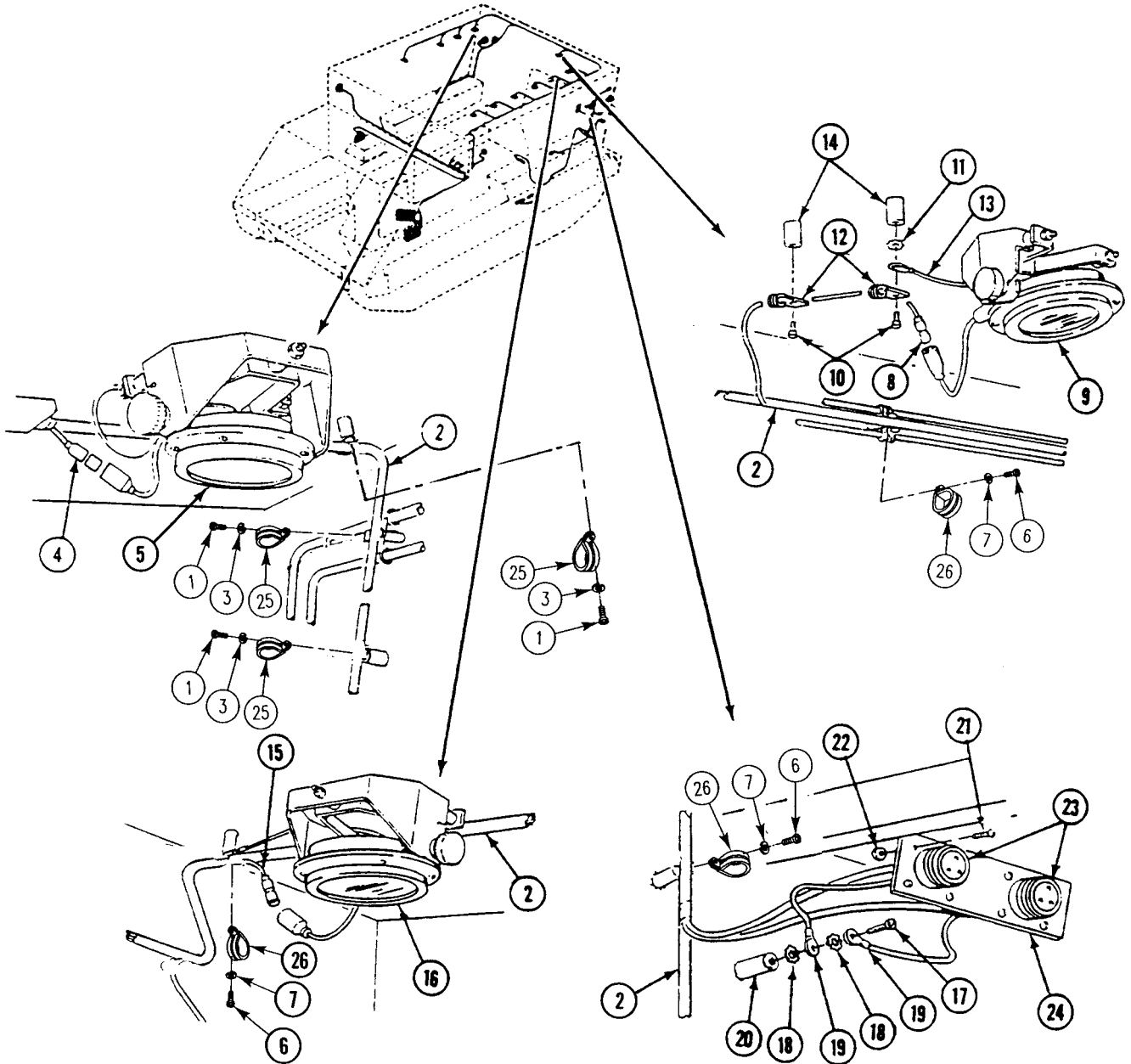

REPLACE REAR MAIN WIRING HARNESS (M1068A3 ONLY) — Continued

0365 00

11. Remove two screws (10), one lockwasher (11), two clamps (12), and ground lead (13) from weldnuts (14). Remove clamps from circuit 38B lead (8). Discard lockwasher.
12. Disconnect five circuit 38C leads (15) from five left side dome lights (16).
13. Remove screw (17), two lockwashers (18), and ground leads (19) from weldnut (20). Discard lockwasher.
14. Remove eight screws (21), locknuts (22), and two circuit 48 connectors (23) from bracket (24). Discard locknuts.

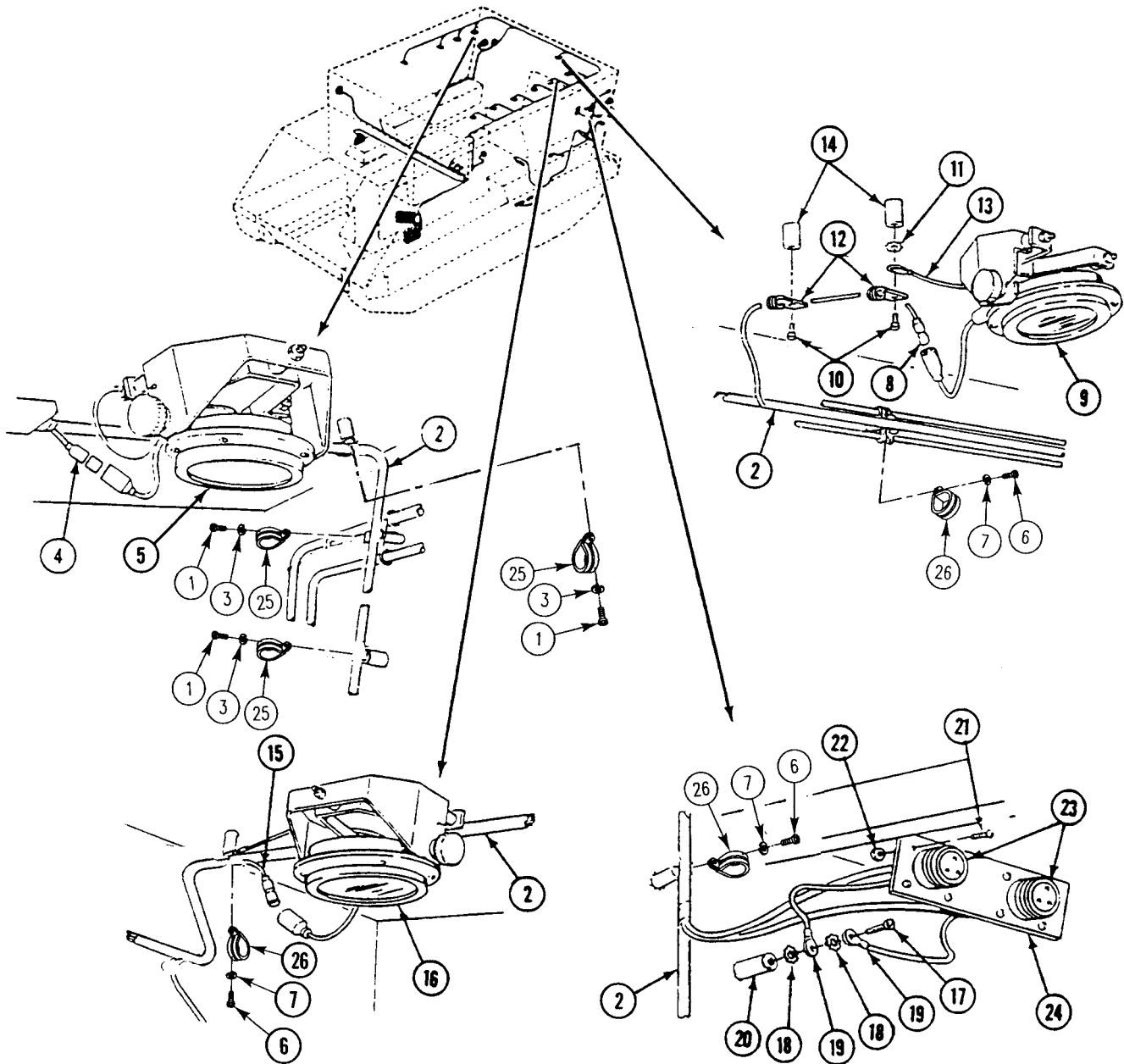

REPLACE REAR MAIN WIRING HARNESS (M1068A3 ONLY) — Continued

0365 00

15. Disconnect circuit 37B lead (1) from left utility outlet lead (2).
16. Disconnect circuit 21 lead (3), circuit 22 lead (4), and circuit 24 lead (5) from left tail light leads (6).
17. Disconnect circuit 38 lead (7), circuit 38A lead (8), and circuit 38E lead (9) from dome light switch (10).
18. Disconnect circuit 38C lead (11) and circuit 38E lead (12) from blackout dome light switch (13).
19. Disconnect circuit 509 and 509A connector (14) from buzzer switch (15).
20. Remove seven screws (16), lockwashers (18), clamps (26), and rear main wiring harness (17) from seven weldnuts. Discard lockwashers.
21. Remove two screws (19), one lockwasher (20), and two clamps (21) from two weldnuts (22). Remove clamps from circuit 30 lead (23) and circuit 509 lead (24). Discard lockwasher.
22. Disconnect circuit 509 lead (24) from buzzer (25).

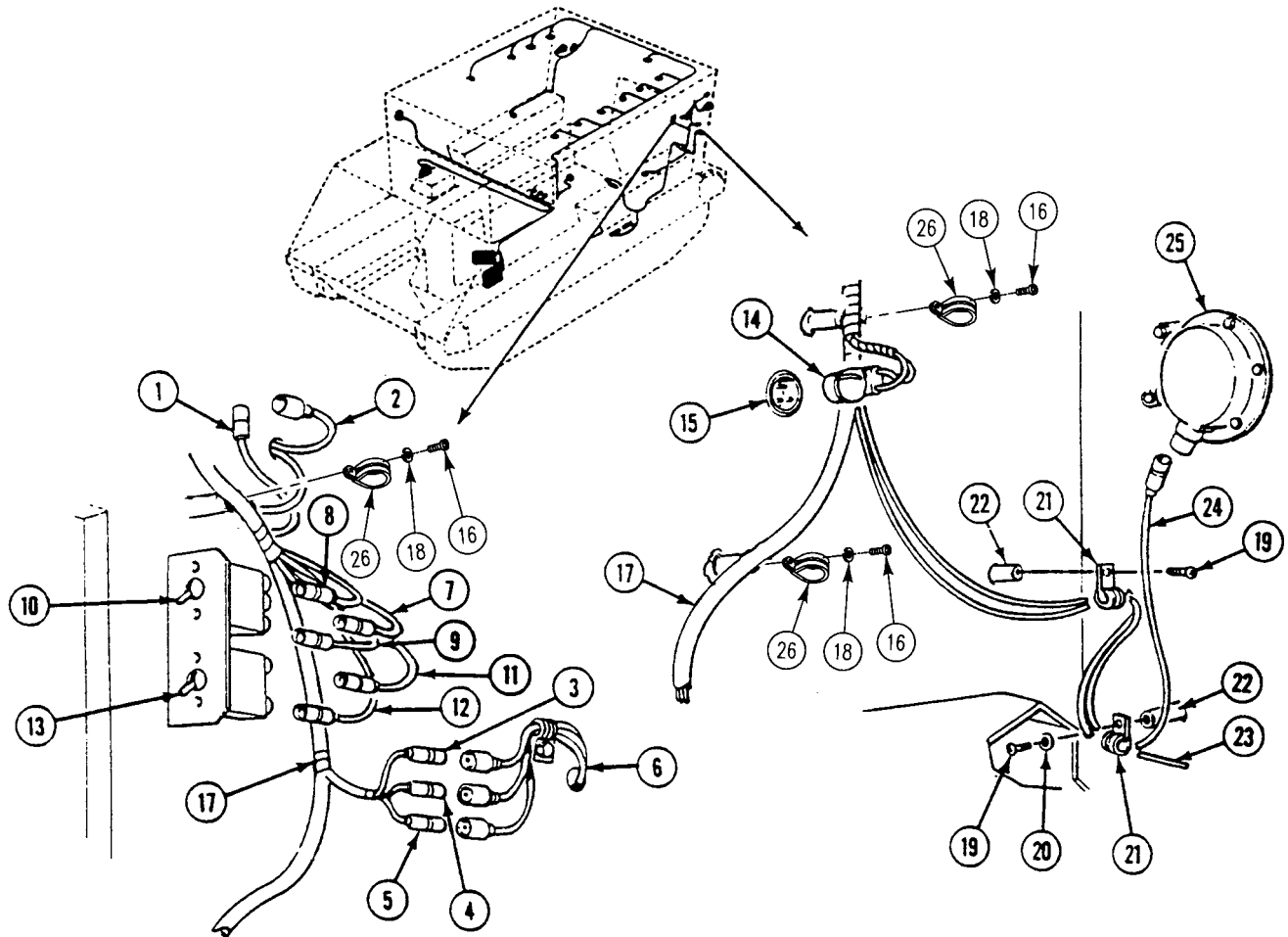

REPLACE REAR MAIN WIRING HARNESS (M1068A3 ONLY) — Continued

0365 00

23. Disconnect circuit 30 lead (1) from left fuel quantity sending unit (2).
24. Remove lockwire (3), one screw (4), lockwasher (5), and ground lead (6) from sending unit (2). Discard lockwire and lockwasher.
25. Remove three screws (7), clamps (8), lockwashers (9), and ground lead (6) from weldnuts (10). Remove clamps from circuit 30 lead (1). Discard lockwashers.
26. Disconnect circuit 402 lead (11) from personnel heater fuel pump (12).
27. Remove screw (13), lockwasher (14), and clamp (15) from weldnut (16). Remove clamp from rear main wiring harness (17). Discard lockwasher.
28. Remove two screws (18), locknuts (19), clamp (20), and rear main wiring harness (17) from floor transverse beam (21). Discard locknuts.
29. Remove screw (22), locknut (23), and clamp (20) from rear main wiring harness (17). Discard locknut.
30. Remove three screws (24), lockwashers (25), clamps (26), and rear main wiring harness (17) from weldnuts. Discard lockwashers.

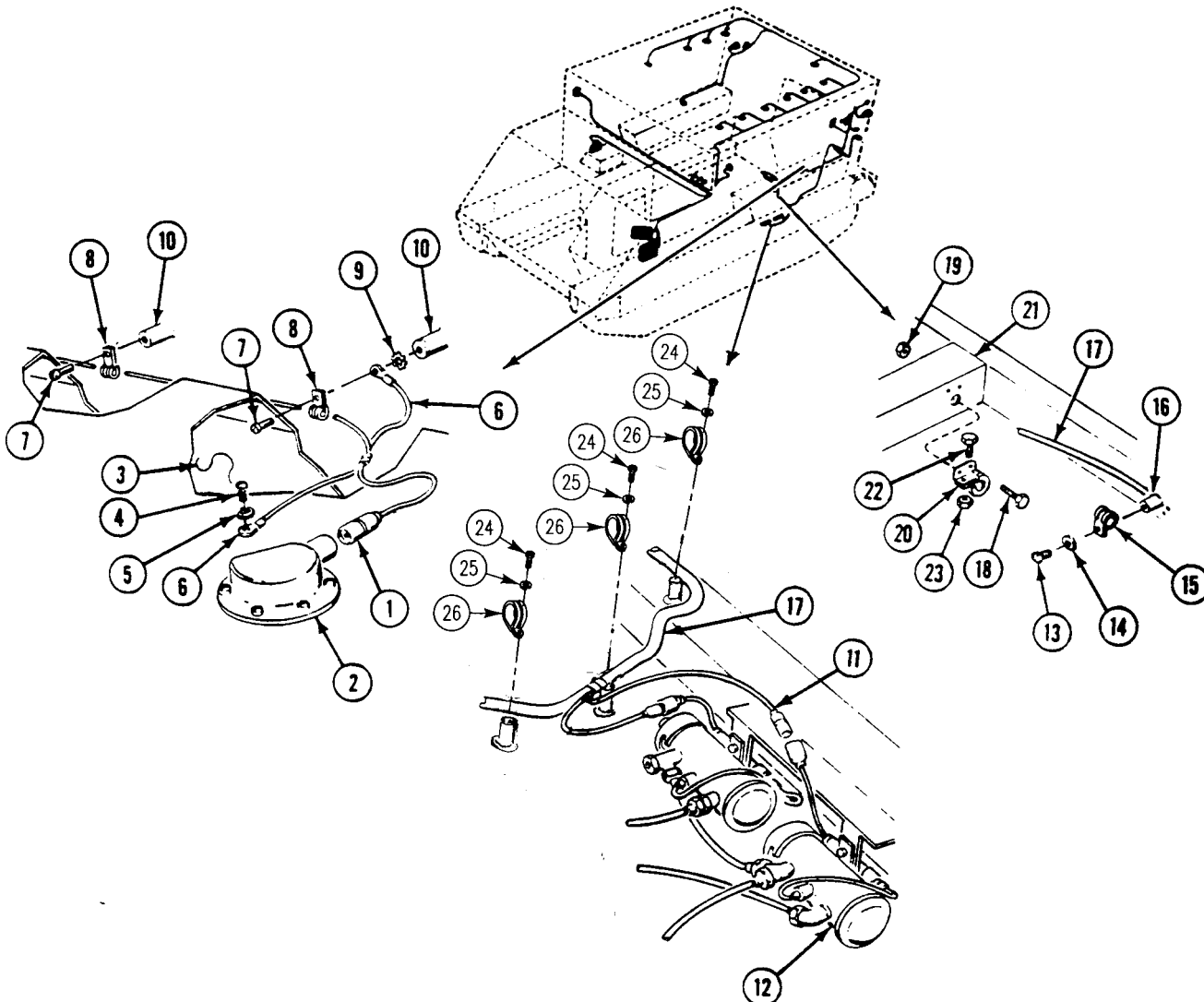

REPLACE REAR MAIN WIRING HARNESS (M1068A3 ONLY) — Continued

0365 00

31. Disconnect circuit 21 lead (1), circuit 22 lead (2), circuit 23 lead (3), and circuit 24 lead (4) from trailer wiring harness (5).
32. Disconnect circuit 451 lead (6) from rear bilge pump (7).
33. Remove screw (8), two lockwashers (9), clamp (10), and trailer wiring harness ground lead (11) from weldnut (12). Remove clamp from rear main wiring harness (13). Discard lockwashers.
34. Pull circuit 21 lead (1), circuit 22 lead (2), circuit 23 lead (3), circuit 24 lead (4), and circuit 451 lead (6) through opening in transverse beam.
35. Remove two screws (14) and clamps (15) from two weldnuts (16). Remove clamps from rear main wiring harness (13).
36. Remove eight screws (17), lockwashers (18), clamps (23), and rear main wiring harness (13) from eight weldnuts.
37. Disconnect circuit 38C lead (19) from left dome light (20).
38. Disconnect circuit 38B lead (21) from front blackout light (22).

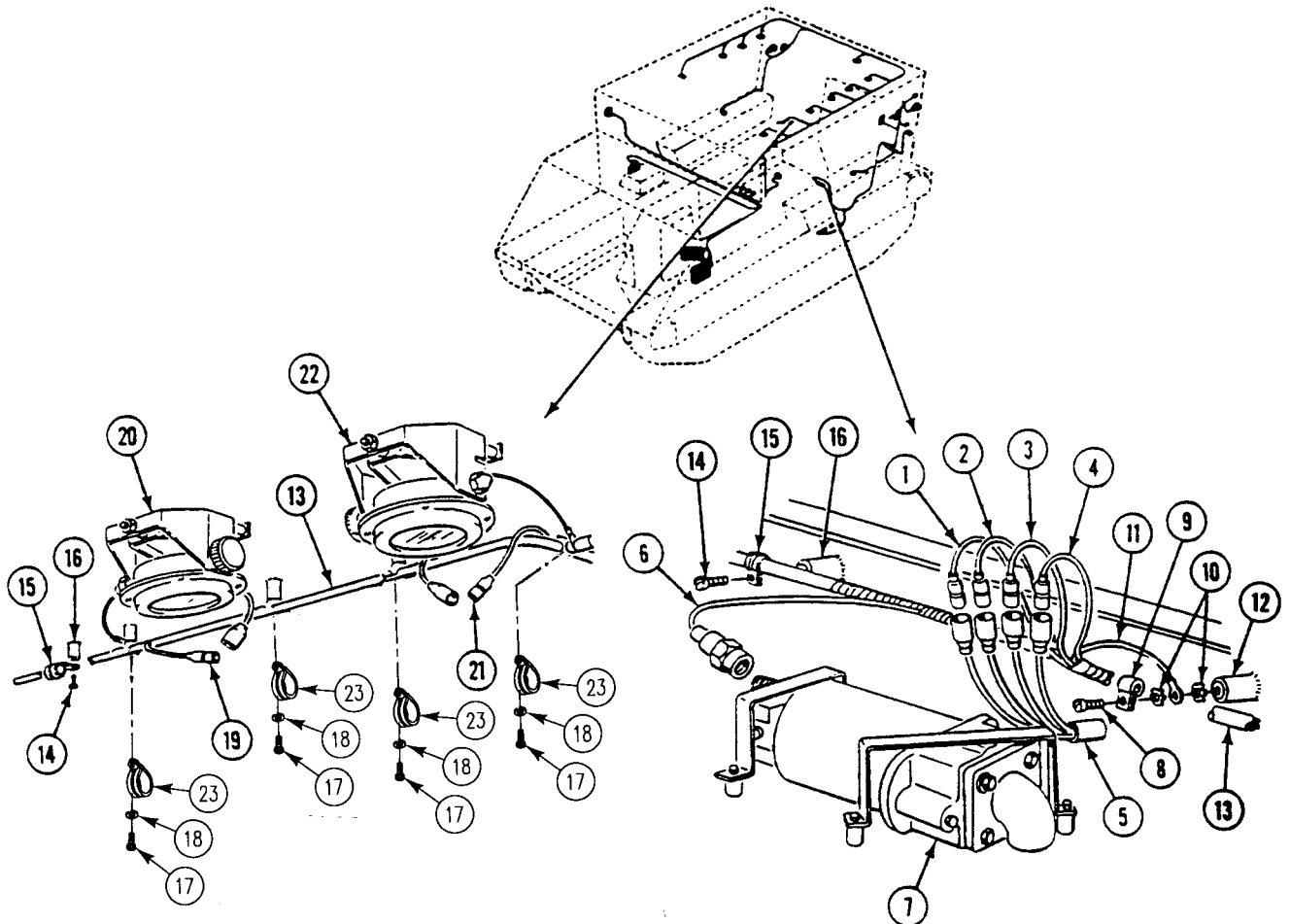

REPLACE REAR MAIN WIRING HARNESS (M1068A3 ONLY) — Continued

0365 00

39. Remove four screws (1), locknuts (2), and circuit 48A connector (3) from bracket (4). Discard locknuts.
40. Remove two screws (5), lockwashers (6), and clamps (7) from two weldnuts (8). Remove clamps from circuit 48A lead (9). Discard lockwashers.
41. Remove screw (10), three lockwashers (11), and ground leads (12) from weldnut (13). Discard lockwashers.
42. Remove screw (14), two lockwashers (16), clamp (25), circuit 48C capacitor (18), and rear main wiring harness (15) from weldnuts. Discard lockwasher.
43. Remove 12 screws (21), locknuts (22), and 3 circuit 48 connectors (23) from bracket (24). Discard locknuts.

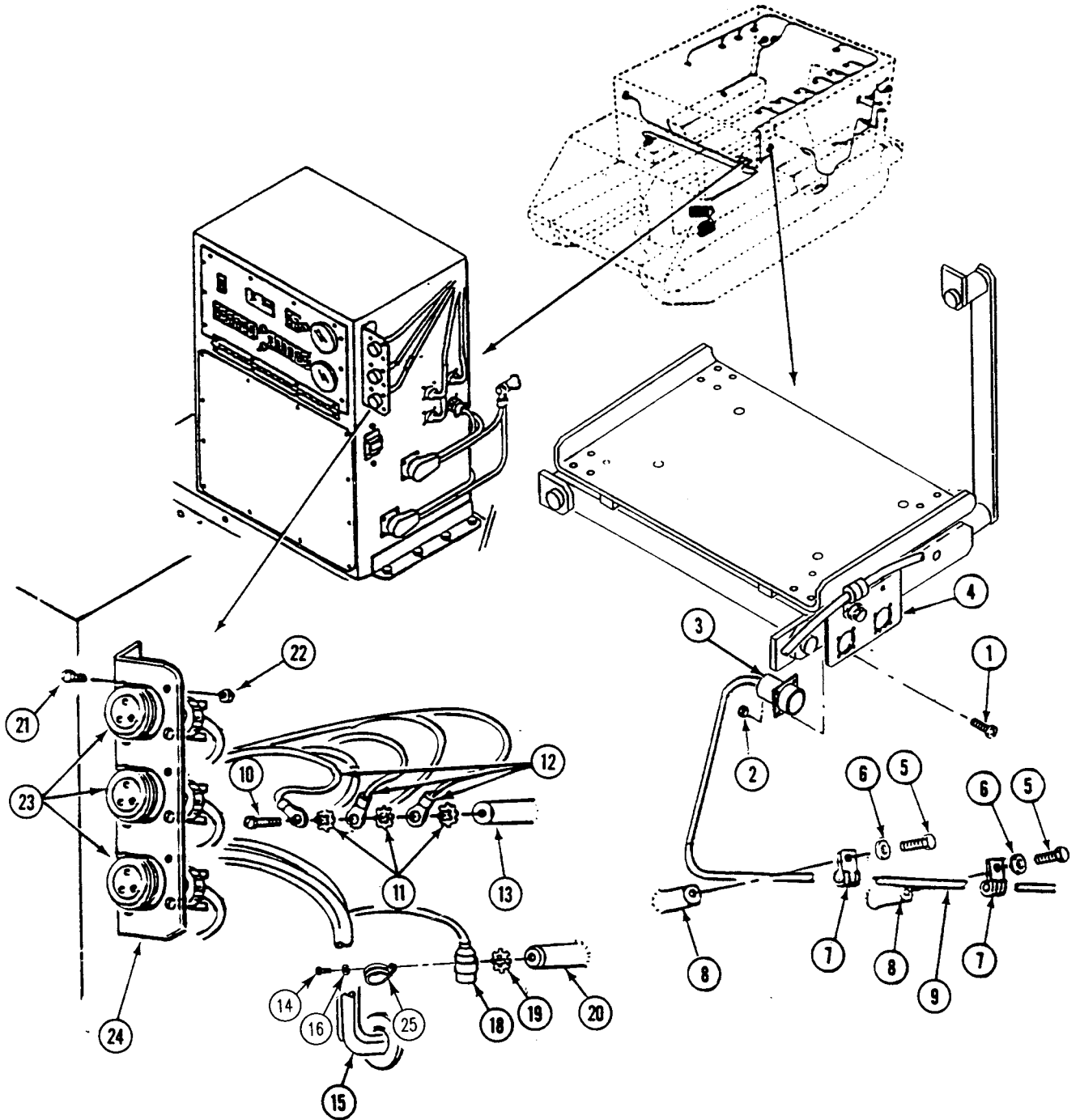

REPLACE REAR MAIN WIRING HARNESS (M1068A3 ONLY) — Continued

0365 00

44. Disconnect circuit 59 lead (1) from blower (2).
45. If NBC unit is installed, disconnect circuit 415 lead (3) from NBC unit.
46. Remove screw (4), lockwasher (5), and clamp (6) from weldnut (7). Remove clamp from circuit 59 lead (1) and circuit 415 lead (3). Discard lockwasher.
47. Remove four screws (8), nuts (9), and circuit 48 connector (10) from bracket (11).
48. Remove screw (12), two lockwashers (13), circuit 48 capacitor (14), and ground lead (15) from weldnut (16). Discard lockwashers.
49. Remove six screws (17) and clamps (18) from six weldnuts (19). Remove clamps from circuit 48 lead (20).

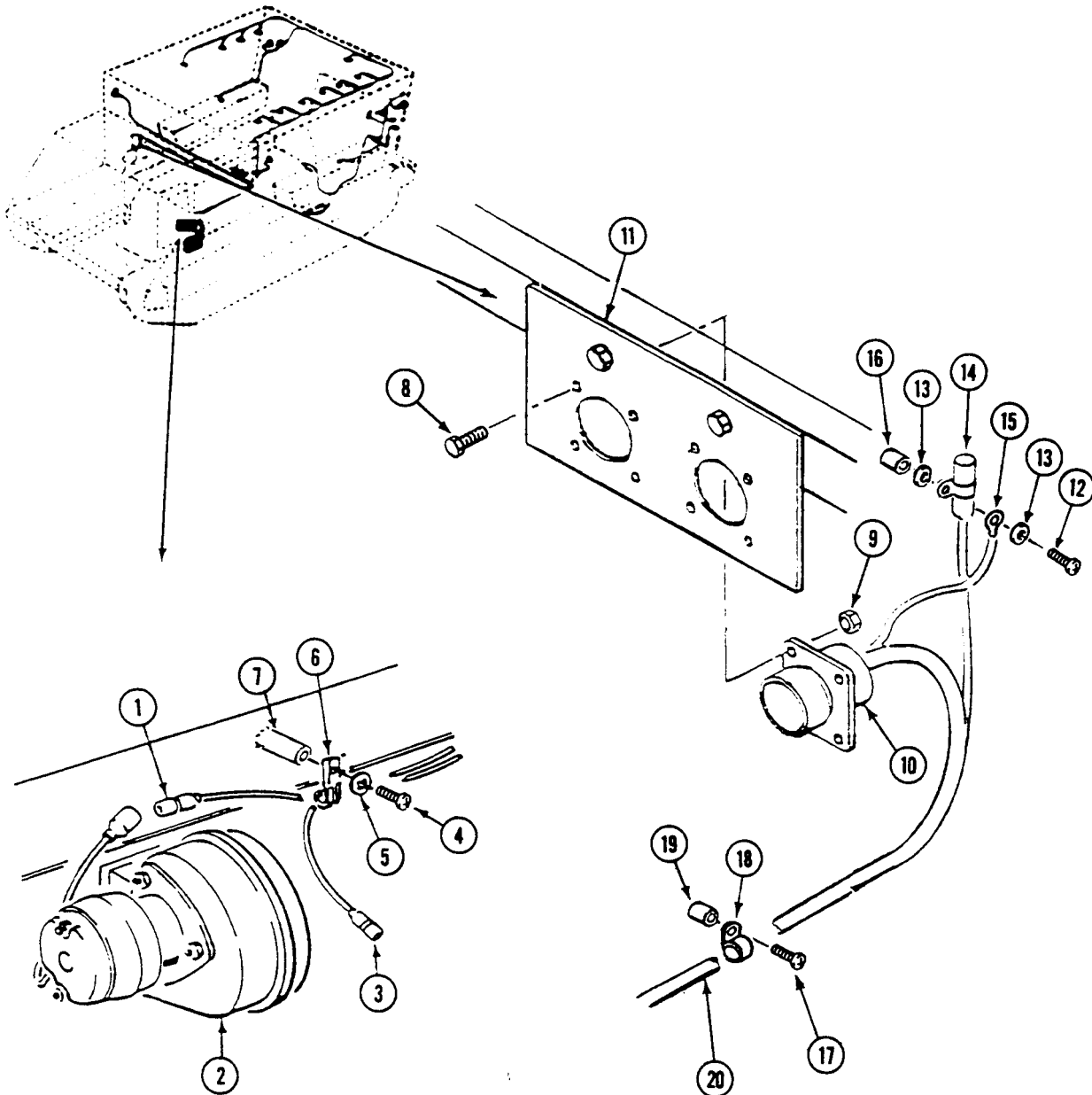

REPLACE REAR MAIN WIRING HARNESS (M1068A3 ONLY) — Continued

0365 00

50. Disconnect circuit 400 lead (1) from personnel heater control box.
51. Disconnect circuit 402 lead (2) from personnel heater wiring harness.
52. If NBC unit is installed, disconnect circuit 415 lead (3) from NBC unit.
53. Remove eight locknuts (4), washers (5), and screws (6). Separate master switch panel (7) from distribution box (8). Discard locknuts.
54. Disconnect wiring harness circuit 10 (9) from three circuit breakers (10)(11)(12) in master switch panel (7).
55. Disconnect wiring harness (13) from circuit 38E lead (14).

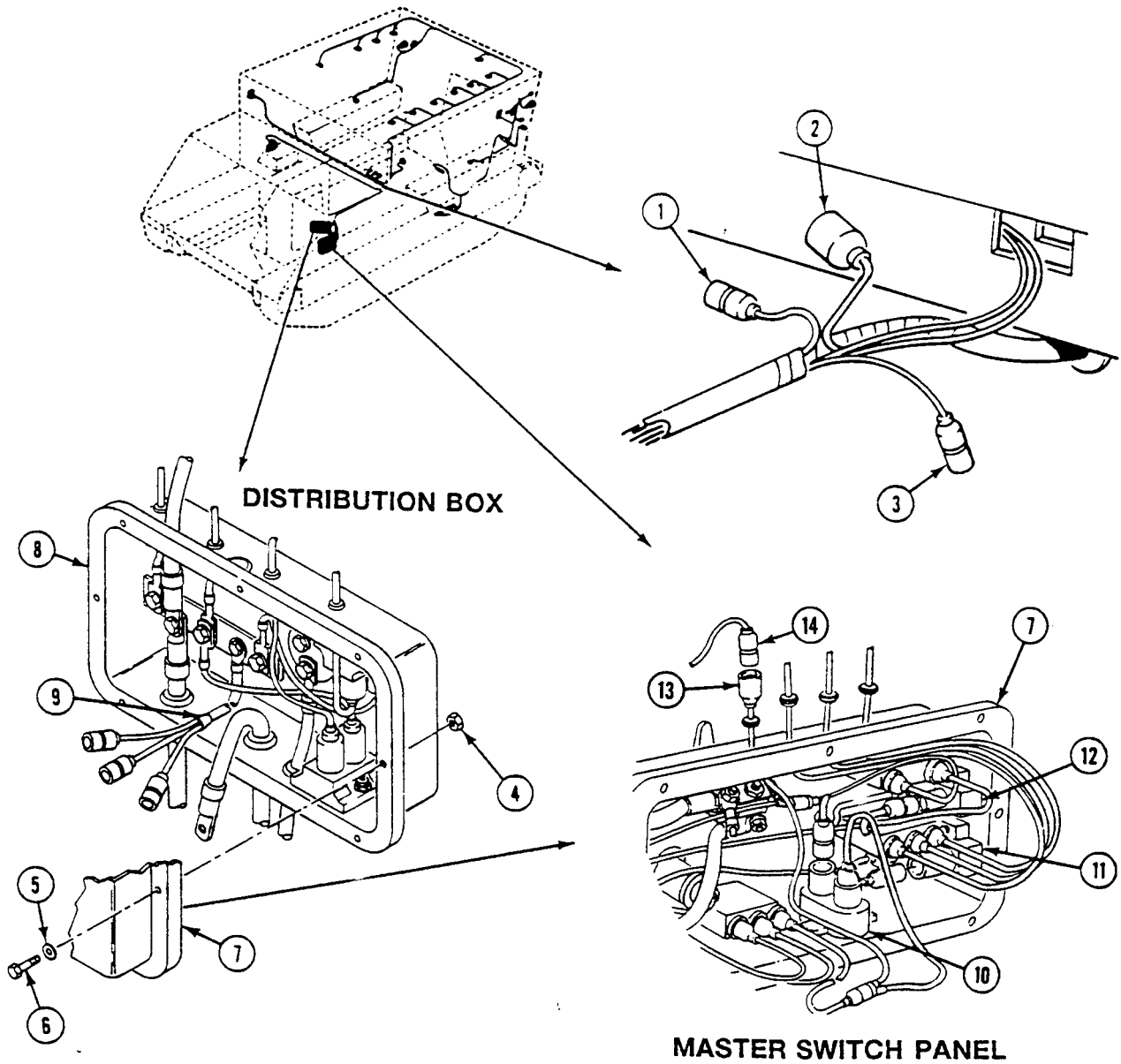

REPLACE REAR MAIN WIRING HARNESS (M1068A3 ONLY) — Continued

0365 00

56. Disconnect circuit 59 lead (1) from blower switch (2).
57. Disconnect circuit 37B leads (3) from blower switch (2) and circuit breaker (4).
58. Remove circuit 59 lead (1), circuit 37B lead (3), and two grommets (5) from master switch panel (6). Discard grommets.
59. Disconnect circuit 37A lead (7) from circuit breaker (8).
60. Disconnect circuit 38 lead (9) and circuit 38A lead (10) from dome light switch (11).
61. Remove circuit 37A lead (7), circuit 38 lead (9), circuit 38A lead (10), and three grommets (12) from master switch panel (6). Discard grommets.

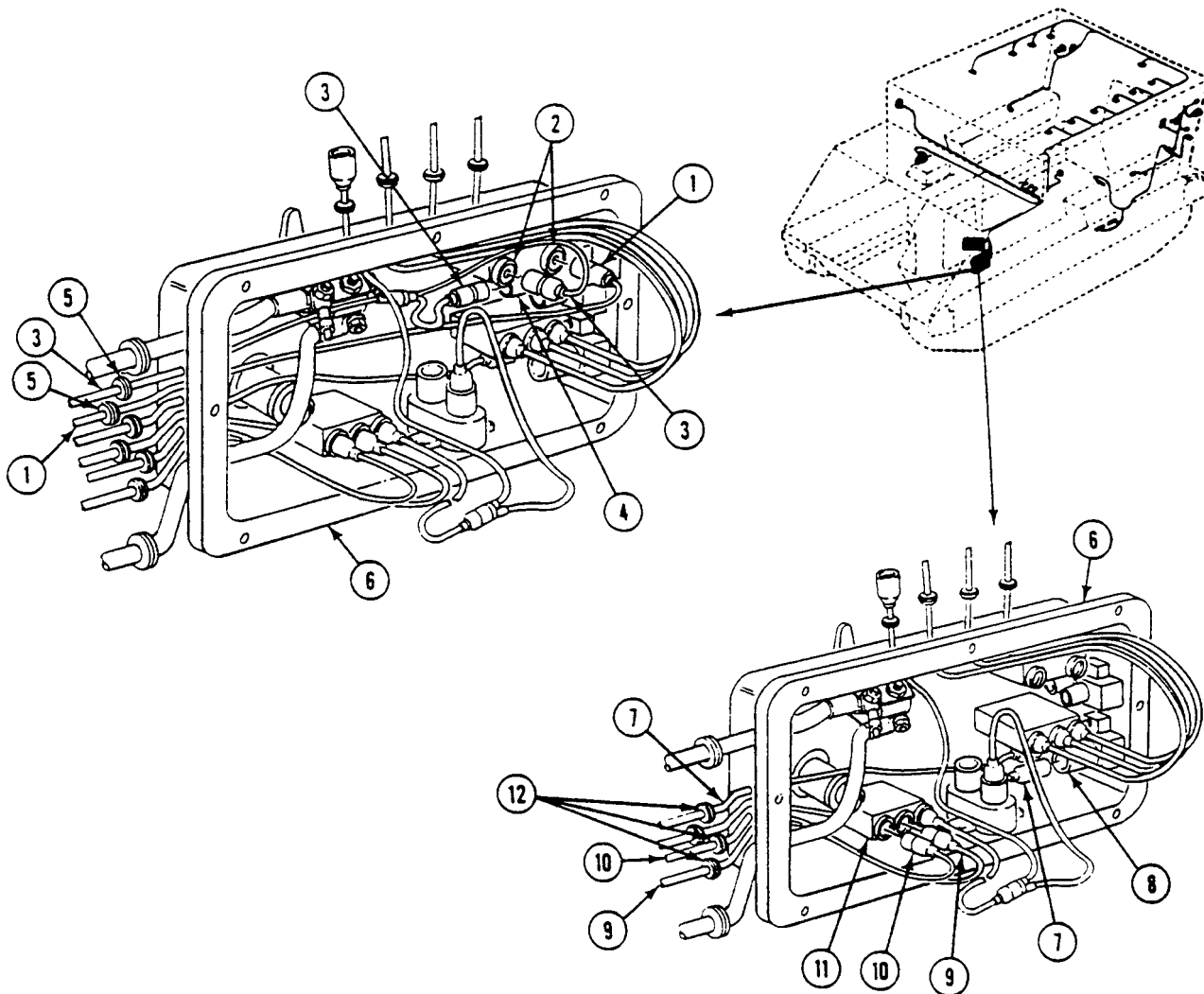

REPLACE REAR MAIN WIRING HARNESS (M1068A3 ONLY) — Continued

0365 00

62. Disconnect circuit 28 lead (1), circuit 29 lead (2), and circuit 30 lead (3) from fuel selector switch (4).
63. Remove circuit 28 lead (1), circuit 29 lead (2), circuit 30 lead (3), and three grommets (5) from master switch panel (6). Discard grommets.
64. Disconnect circuit 450 lead (7) from circuit breaker (8).
65. Disconnect circuit 450B lead (9) from circuit breaker (10).
66. Remove circuit 450 lead (7) and grommet (11) from distribution box (12). Discard grommet.
67. Remove circuit 450B lead (9) and grommet (13) from distribution box (12). Discard grommet.

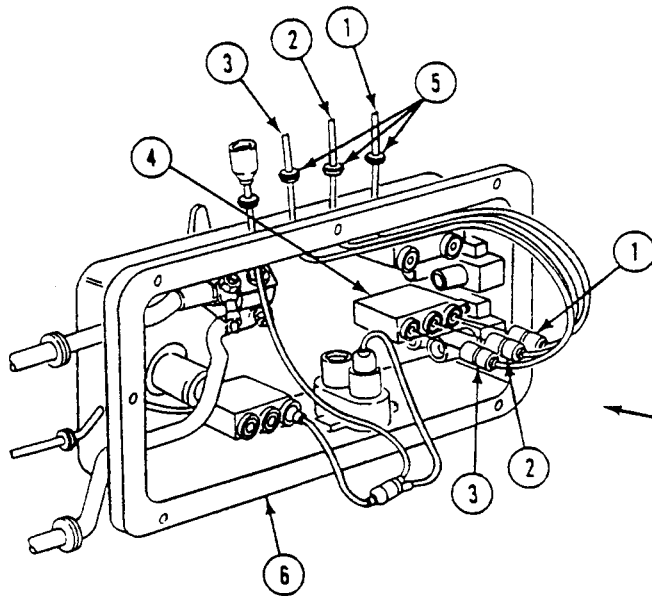

MASTER SWITCH PANEL

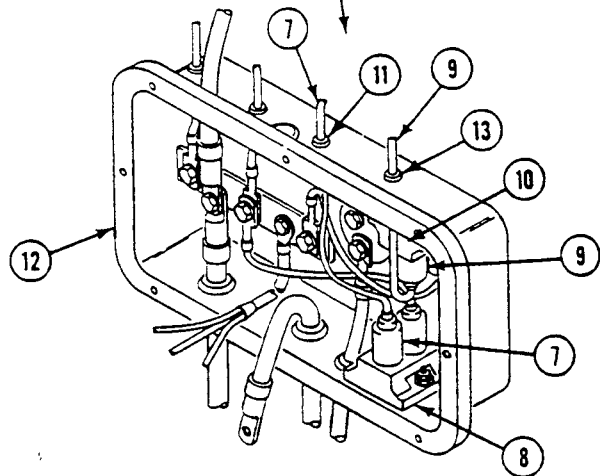
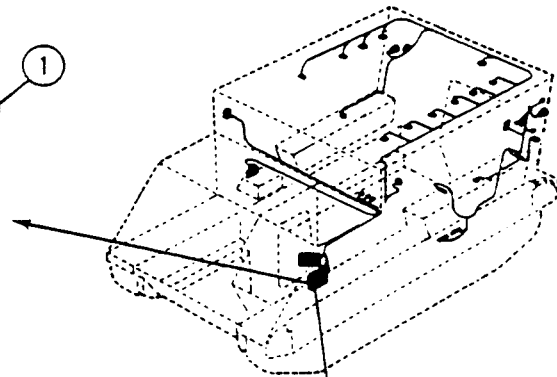

DISTRIBUTION BOX

REPLACE REAR MAIN WIRING HARNESS (M1068A3 ONLY) — Continued

0365 00

68. Remove two nuts (1), mounts (2) and (3), flat washers (4), and screws (5) that secure instrument panel (6) to two struts (7).
69. Support panel (6). Remove two screws (8), flat washers (9), one lockwasher (10), and ground lead (11) from two mounts (12) and upper support (13). Discard lockwasher.
70. Support panel (6) on two struts (7) to gain access to rear of panel.
71. Disconnect circuit 28 lead (14) from fuel gage.
72. Disconnect circuit 451B lead (15) from rear bilge pump ON indicator light.
73. Disconnect circuit 38 lead (16) from instrument panel wiring harness.
74. Disconnect circuit 450 lead (17), circuit 450B lead (18), and circuit 451A lead (19) from bilge pump switch.
75. Disconnect circuit 21 lead (20), circuit 22 lead (21), circuit 23 lead (22), and circuit 24 lead (23) from front main wiring harness.

REPLACE REAR MAIN WIRING HARNESS (M1068A3 ONLY) — Continued

0365 00

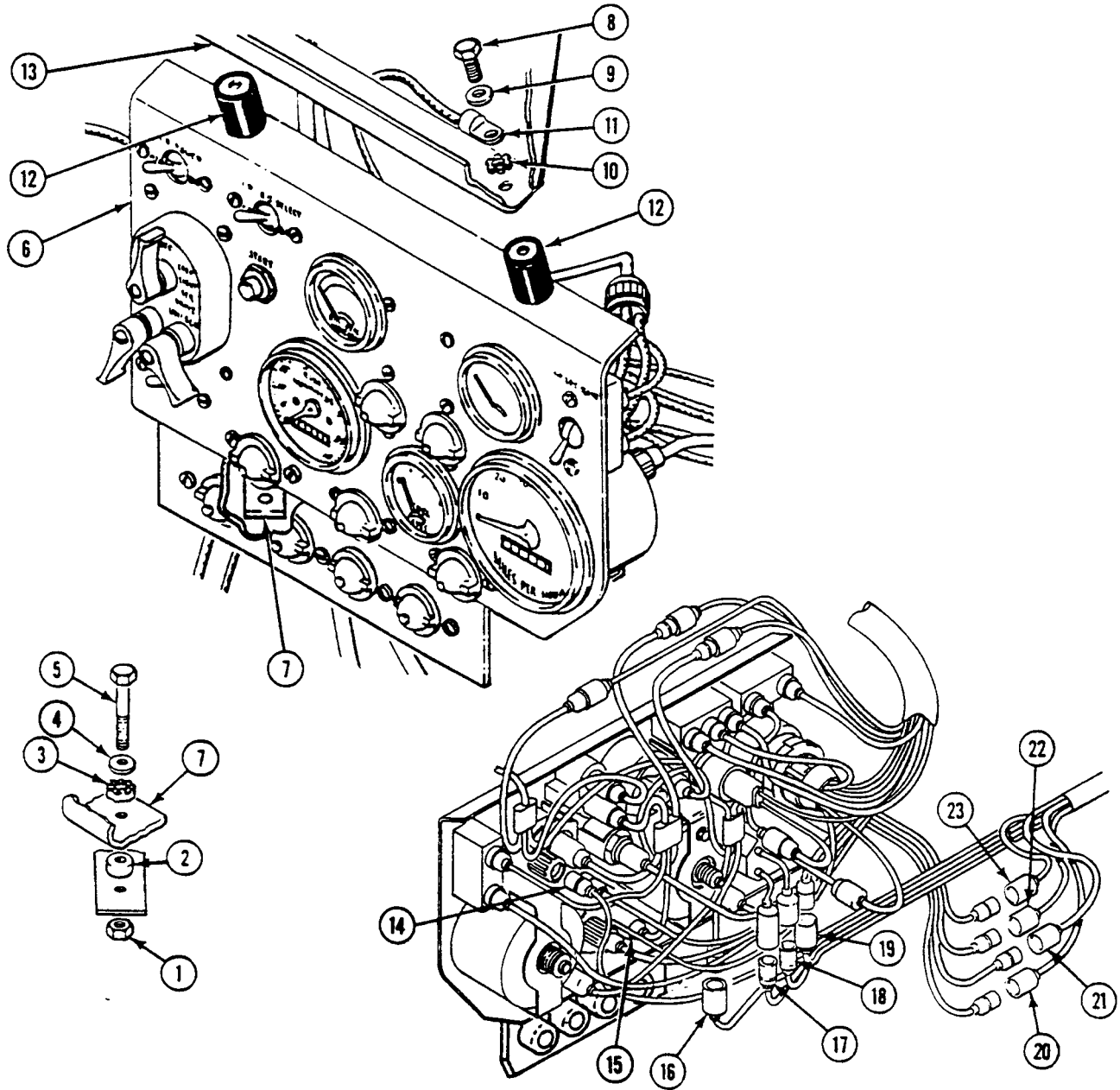

REPLACE REAR MAIN WIRING HARNESS (M1068A3 ONLY) — Continued

0365 00

76. Remove screw (1), nut (2), circuit 6 lead (3), circuit 48B lead (4), and W4 cable (5) from battery terminal (6).
77. Remove circuit 48B lead (4), circuit 6 lead (3), and W4 cable (5) from battery box (8).
78. Remove three screws (9), lockwashers (10), and clamps (11) from circuit 48B lead (4). Discard lockwashers.
79. Disconnect circuit 38 lead (16), circuit 38B lead (12), and circuit 38C lead (13) from ramp door switch (14).
80. Remove rear main wiring harness (15) from carrier.

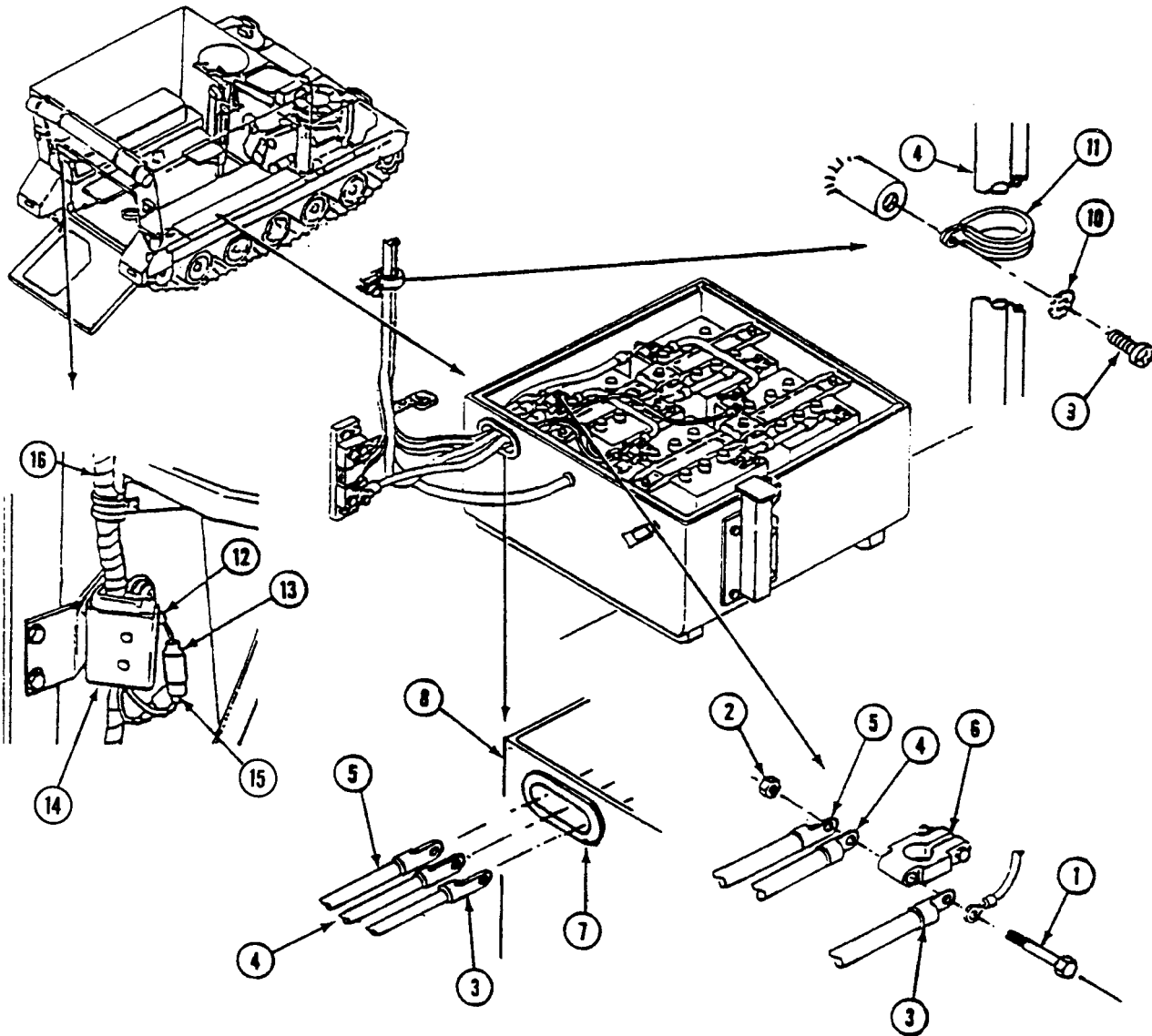

TEST AND INSPECTION

INSPECT AND REPAIR

1. Inspect for damaged leads, connectors, and terminals. Repair as needed (WP 0382 00).

INSTALLATION

1. Install main rear wiring harness (15) in carrier.
2. Connect circuit 38 lead (16), circuit 38B lead (12), and circuit 38C lead (13) to ramp door switch (14).
3. Install three clamps (11), new lockwashers (10), and screws (9) on circuit 48B lead (4).
4. Install circuit 6 lead (3), circuit 48B lead (4), and W4 cable (5) through grommet (7). Connect leads to battery terminal (6) with screw (1) and nut (2).

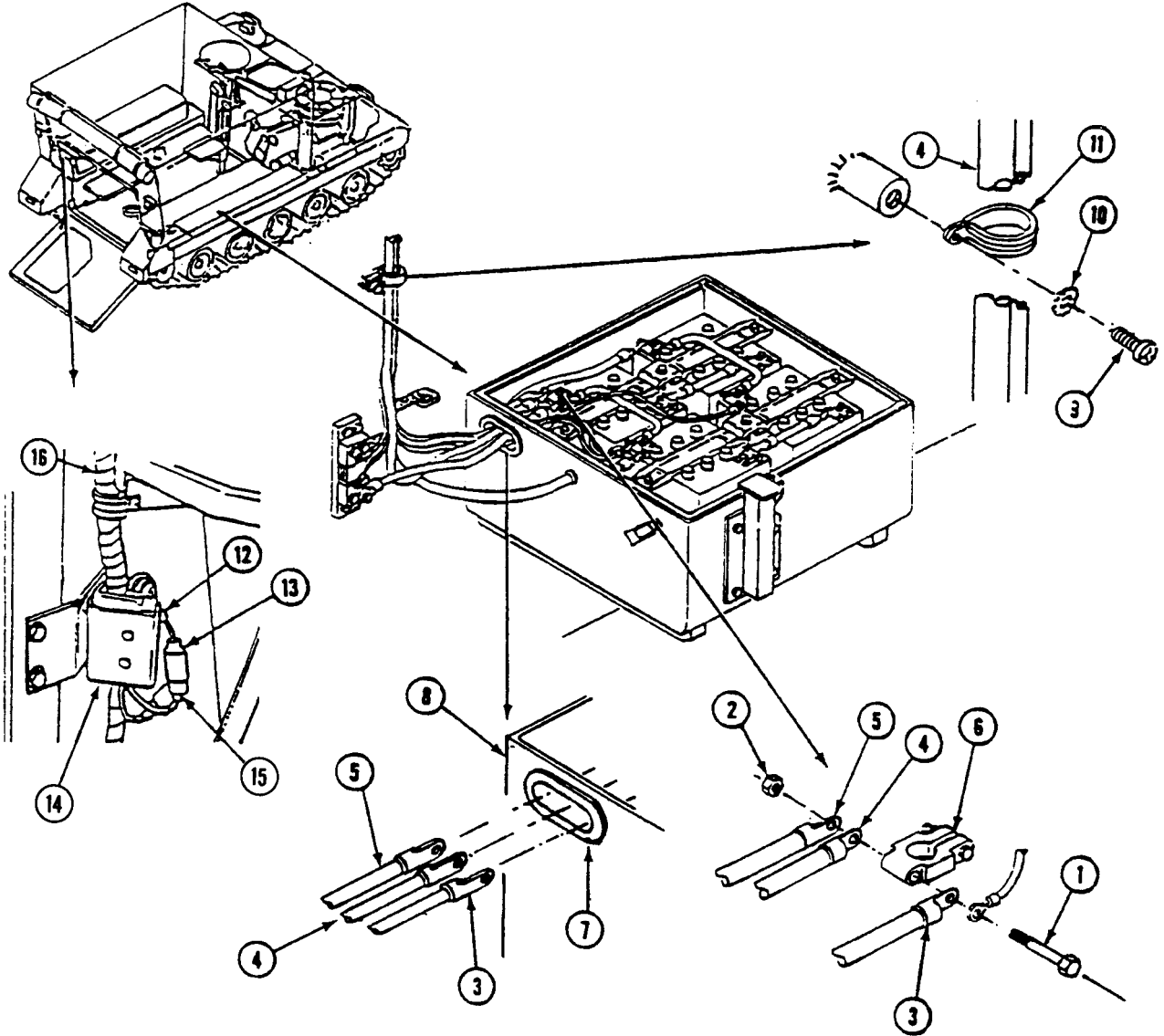

REPLACE REAR MAIN WIRING HARNESS (M1068A3 ONLY) — Continued

0365 00

5. Connect circuit 21 lead (1), circuit 22 lead (2), circuit 23 lead (3), and circuit 24 lead (4) to front main wiring harness.
6. Connect circuit 450 lead (5), circuit 450B lead (6), and circuit 451A lead (7) to bilge pump switch.
7. Connect circuit 38 lead (8) to instrument panel wiring harness.
8. Connect circuit 451B lead (9) to rear bilge pump ON indicator light.
9. Connect circuit 28 lead (10) to fuel gage.
10. Support instrument panel (11) on two struts (12).
11. Install ground lead (13), new lockwasher (14), and instrument panel (11) with two mounts (16) on upper support (15). Secure with two screws (17) and flat washers (18).
12. Install panel (11) on two struts (12). Secure with two nuts (19), mounts (20)(21), flat washers (22), and screws (23).

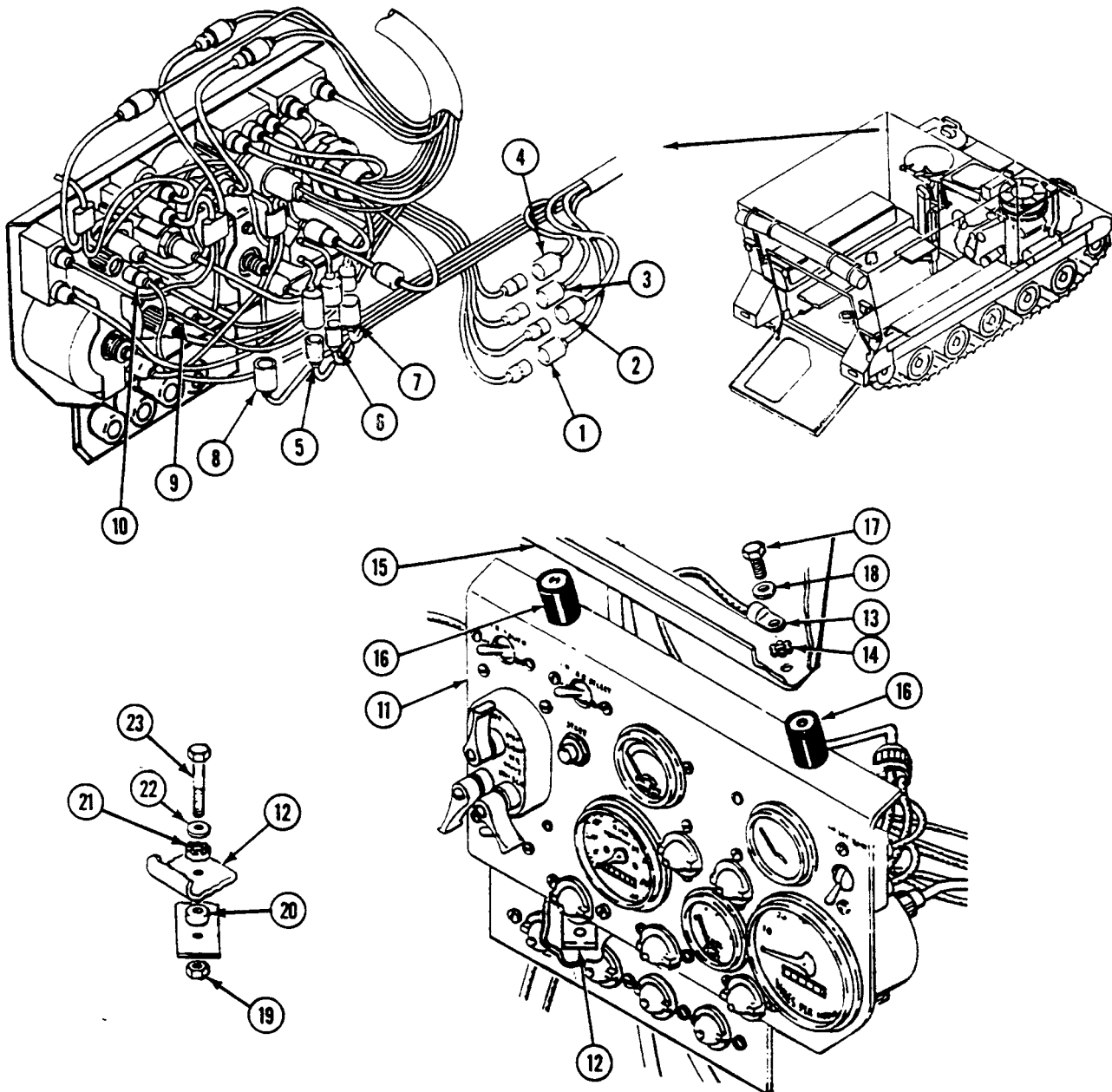

REPLACE REAR MAIN WIRING HARNESS (M1068A3 ONLY) — Continued

0365 00

13. Install circuit 450B lead (1) and new grommet (2) in distribution box (3).
14. Install circuit 450 lead (4) and new grommet (5) in distribution box (3).
15. Connect circuit 450B lead (1) to circuit breaker (6).
16. Connect circuit 450 lead (4) to circuit breaker (7).
17. Install circuit 28 lead (8), circuit 29 lead (9), circuit 30 lead (10), and three new grommets (11) in master switch panel (12).
18. Connect circuit 28 lead (8), circuit 29 lead (9), and circuit 30 lead (10) to fuel selector switch (13).
19. Install circuit 37A lead (14), circuit 38 lead (15), circuit 38A lead (16), and three new grommets (17) in master switch panel (12).
20. Connect circuit 38 lead (15) and circuit 38A lead (16) to dome light switch (18).
21. Connect circuit 37A lead (14) to circuit breaker (19).

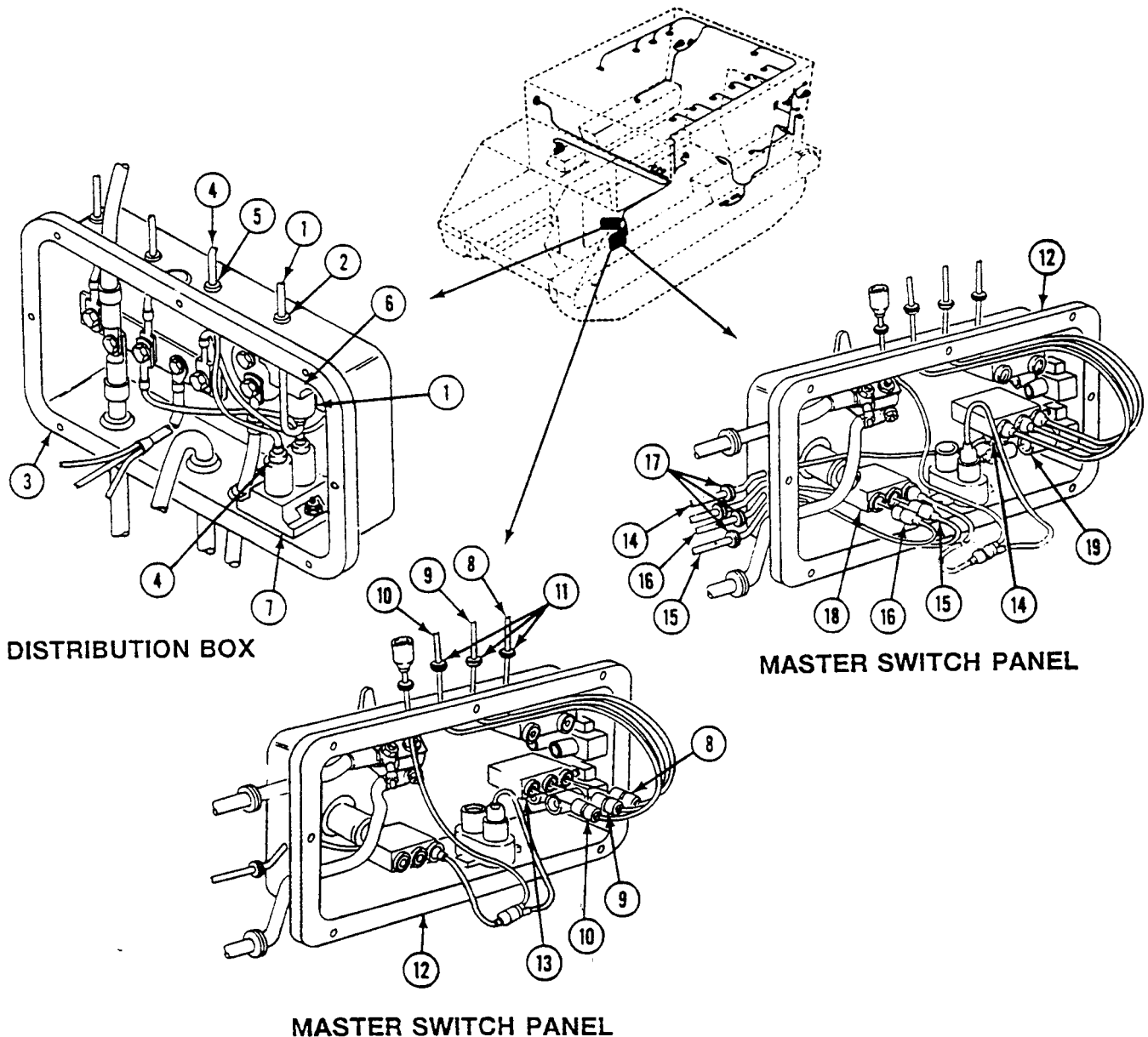

22. Install circuit 59 lead (1), circuit 37B lead (2), and two grommets (3) in master switch panel (4).
23. Connect circuit 37B lead (2) to blower switch (5) and circuit breaker (6).
24. Connect circuit 59 lead (1) to blower switch (5).

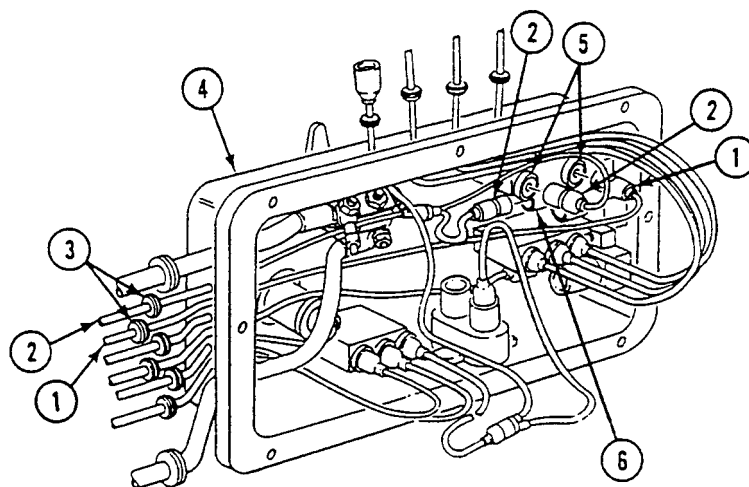

MASTER SWITCH PANEL

25. Connect wiring harness (7) to circuit 38E lead (8).
26. Connect wiring harness circuit 10 (9) to three circuit breakers (10)(11)(12) in master switch panel (4).

NOTE

Inspect gasket. Replace if damaged.

27. Install master switch panel (4) on distribution box (14). Secure with eight screws (15), washers (16), and new locknuts (17).

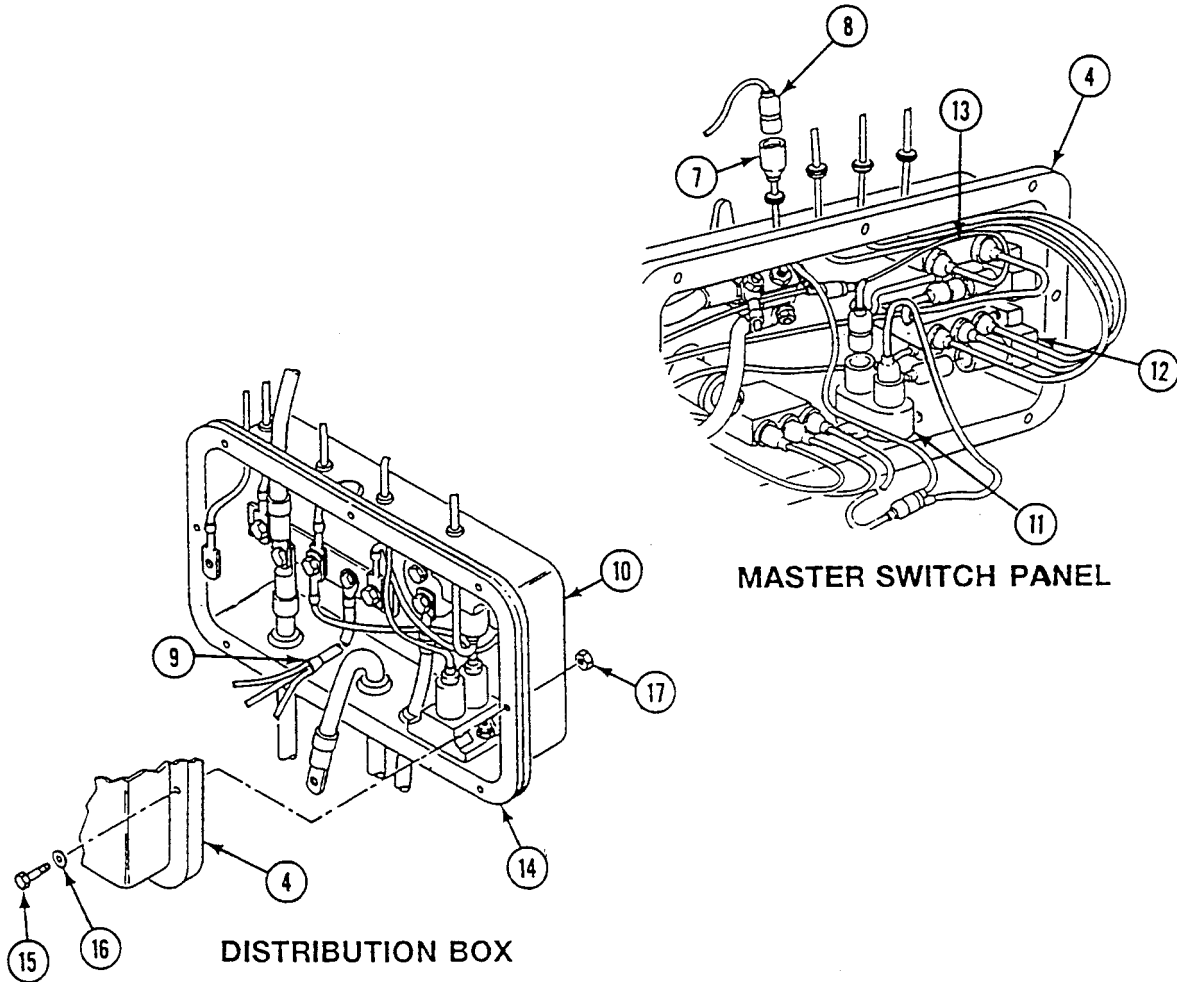

REPLACE REAR MAIN WIRING HARNESS (M1068A3 ONLY) — Continued

0365 00

28. If NBC unit is installed, connect circuit 415 lead (1) to NBC unit.
29. Connect circuit 402 lead (2) to personnel heater wiring harness.
30. Connect circuit 400 lead (3) to personnel heater control box.
31. Install six clamps (4) on circuit 48 lead (5). Secure clamps to weldnuts (6) with screws (7).
32. Install two new lockwashers (8), circuit 48 capacitor (9), and ground lead (10) on weldnut (11). Secure with screw (12).
33. Install circuit 48 connector (13) on bracket (14). Secure with four screws (15) and nuts (16).

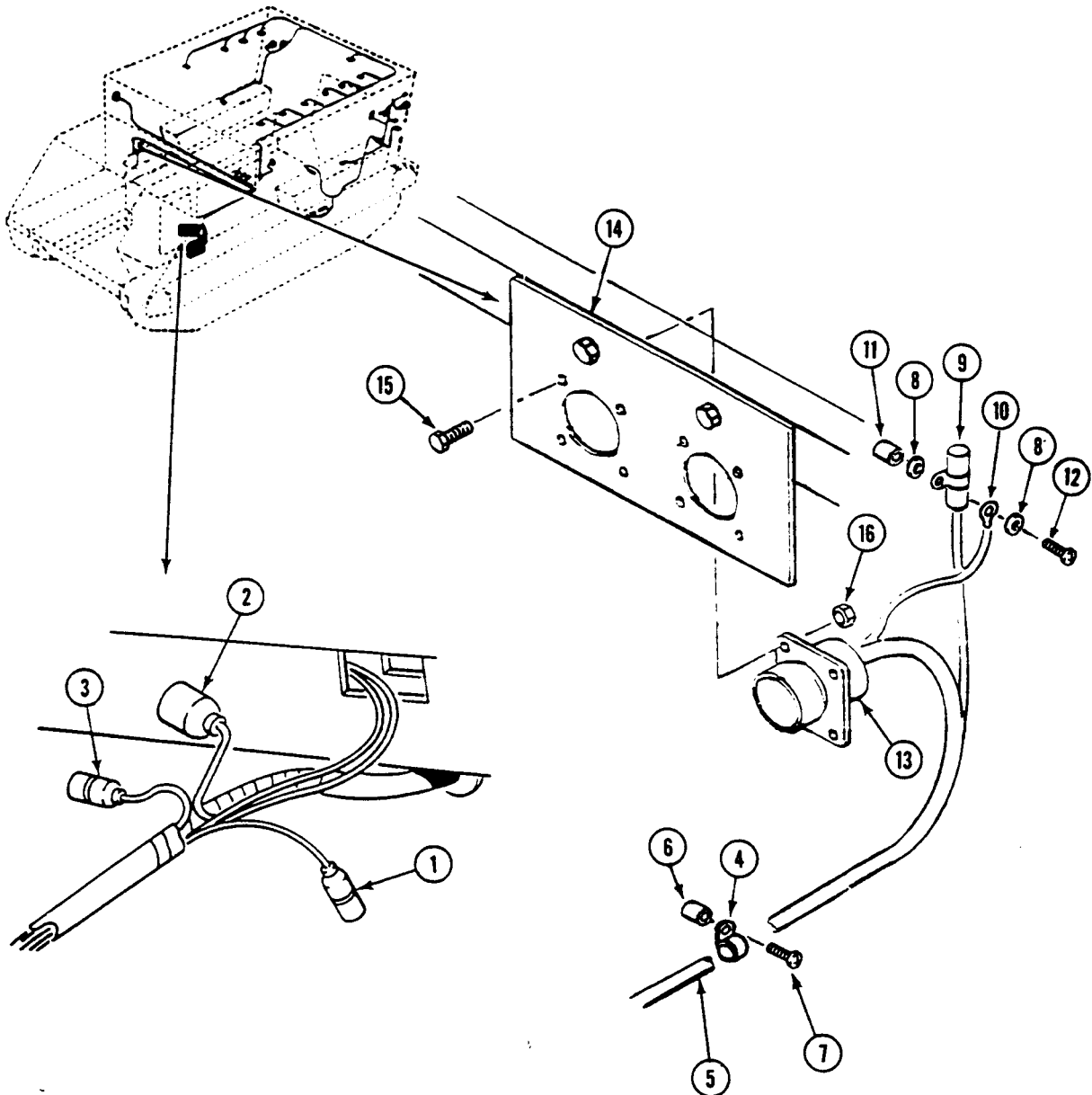

34. Install circuit 415 lead (1) and circuit 59 lead (2) in clamp (3). Secure clamp on weldnut (4) with new lockwasher (5) and screw (6).

35. If NBC unit is installed, connect circuit 415 lead (1) to NBC unit.

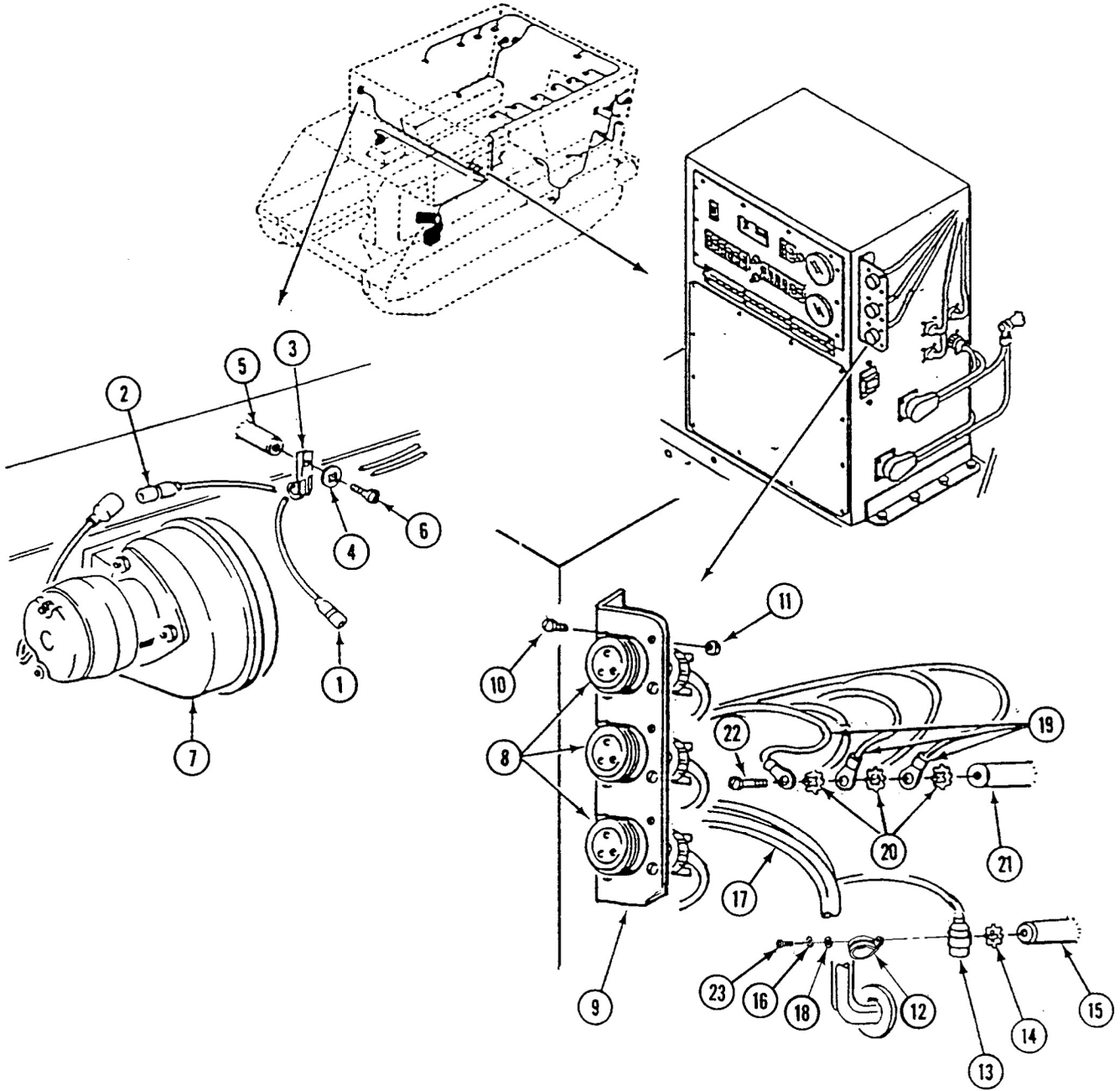

REPLACE REAR MAIN WIRING HARNESS (M1068A3 ONLY) — Continued

0365 00

36. Connect circuit 59 lead (2) to blower (7).
37. Install three circuit 48 connectors (8) on bracket (9). Secure with 12 screws (10) and new locknuts (11).
38. Install clamp (12) on rear main wiring harness (17).
39. Install clamp (12) with rear main wiring harness (17), circuit 48C capacitor (13), and new lockwasher (14) on weldnut (15). Secure with new lock washer (16), washer (18), and screw (23).
40. Install three ground leads (19) and new lockwashers (20) on weldnut (21). Secure with screw (22).

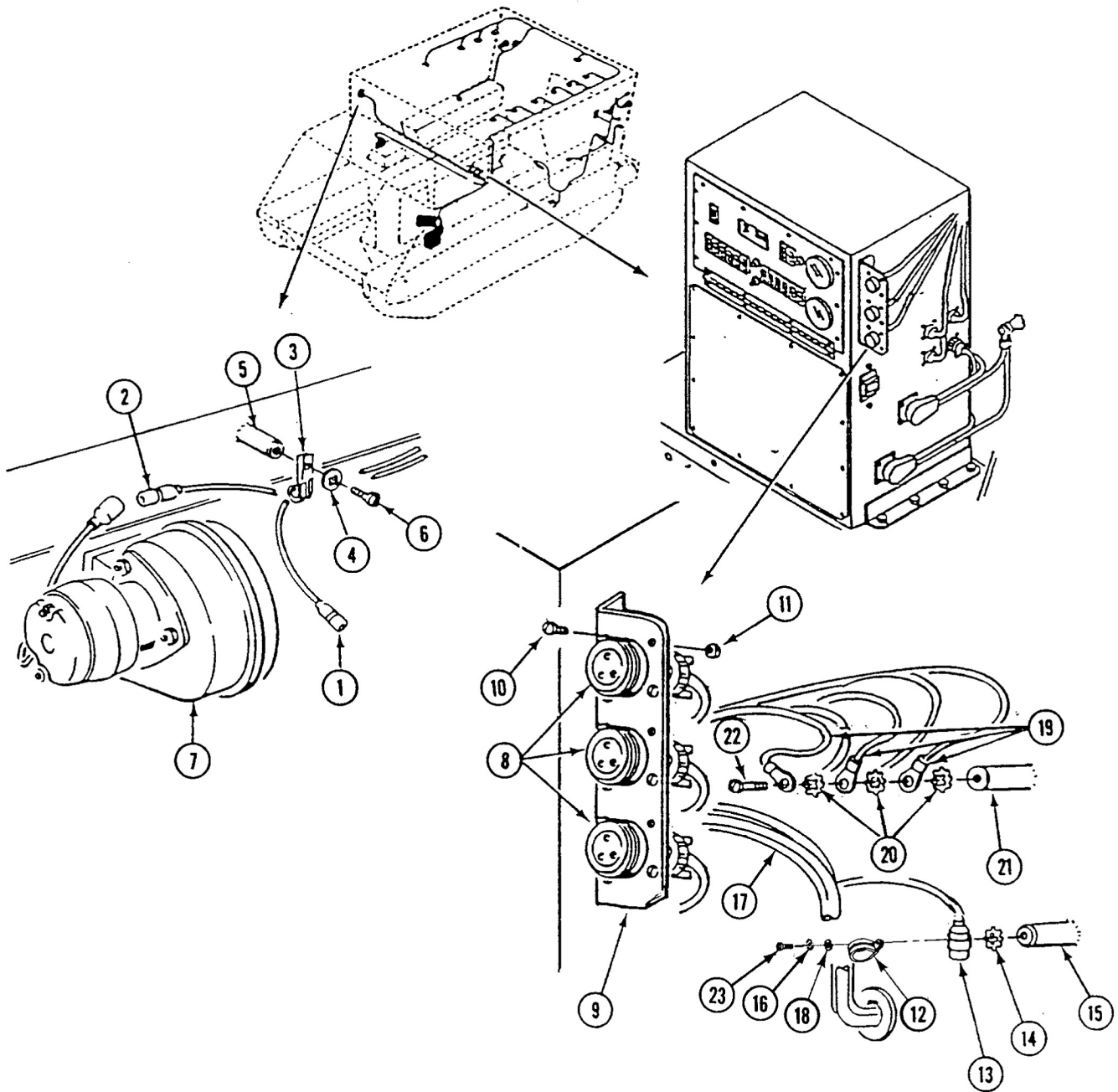

REPLACE REAR MAIN WIRING HARNESS (M1068A3 ONLY) — Continued

0365 00

41. Install circuit 48A lead (1) in two clamps (2). Secure clamps on two weldnuts (3) with two screws (4) and new lockwashers (5).
42. Install circuit 48A connector (6) on bracket (7). Secure with four screws (8) and new locknuts (9).
43. Connect circuit 38B lead (10) to front blackout light (11).

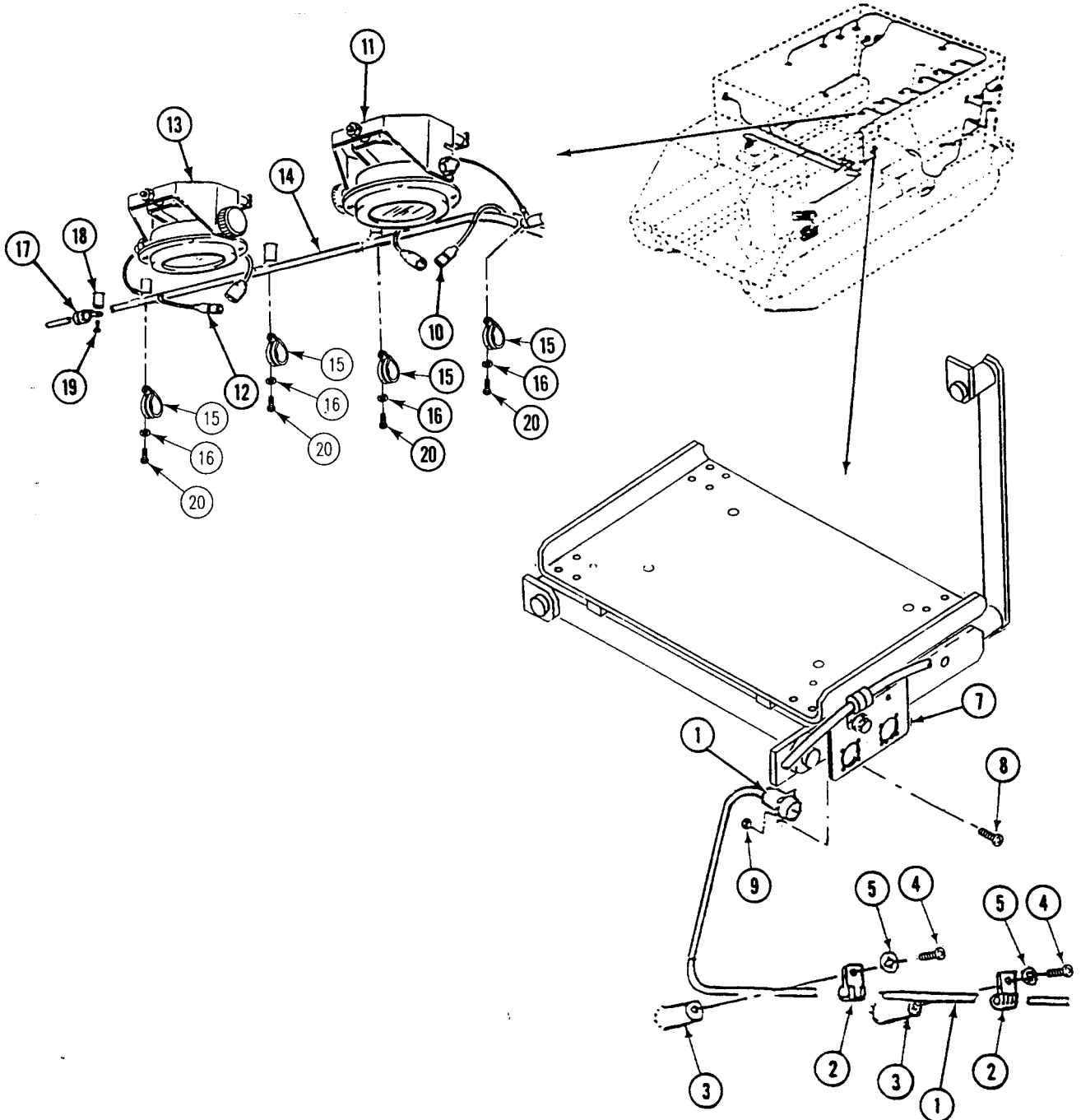

REPLACE REAR MAIN WIRING HARNESS (M1068A3 ONLY) — Continued

0365 00

44. Connect circuit 38C lead (12) to left dome light (13).
45. Install rear main wiring harness (14) on eight weldnuts. Secure with eight clamps (15), new lockwashers (16) and screws (20).
46. Install two clamps (17) on rear main wiring harness (14) Secure clamps on two weldnuts (18) with screws (19).

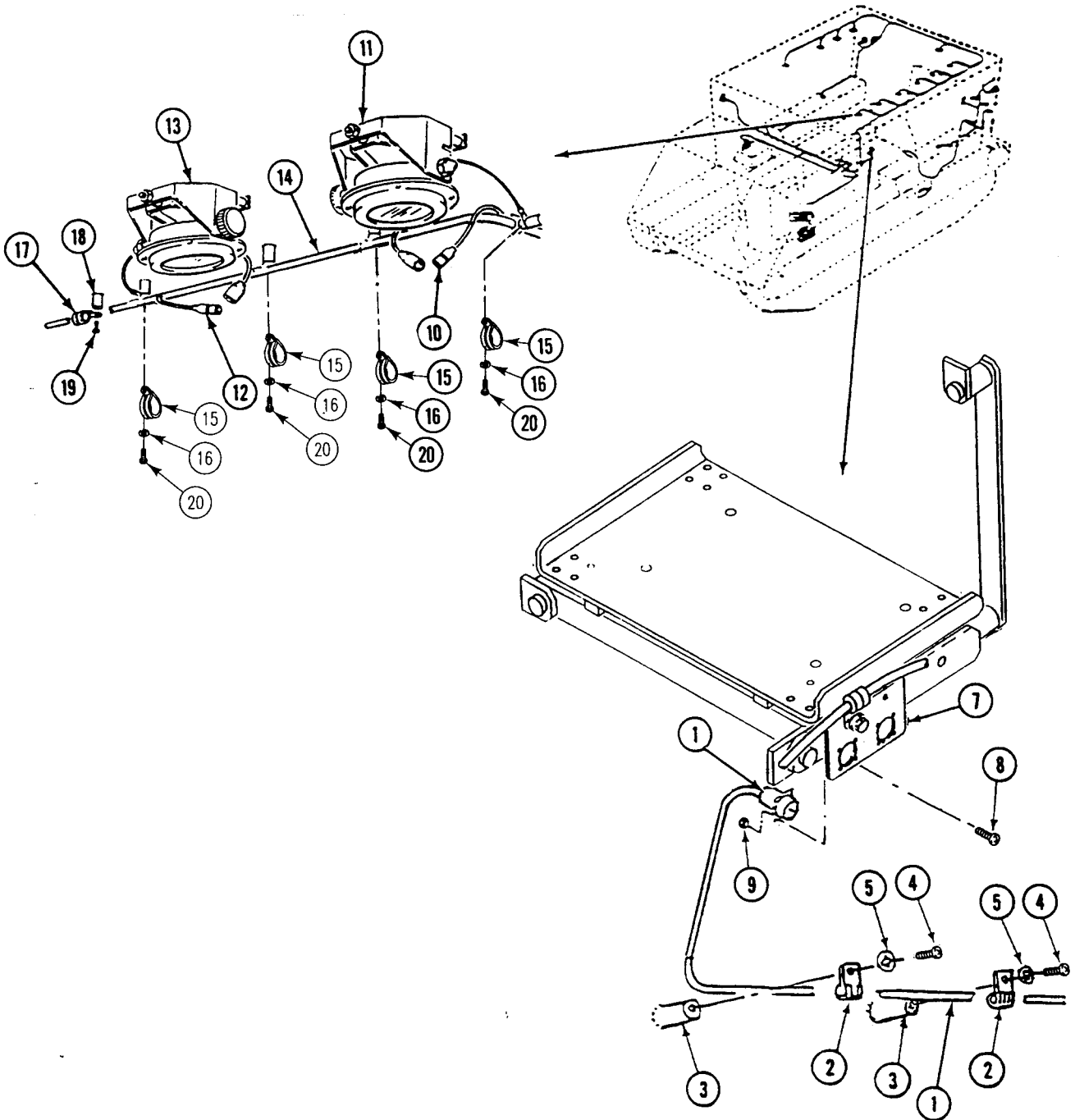

REPLACE REAR MAIN WIRING HARNESS (M1068A3 ONLY) — Continued

0365 00

47. Pull circuit 21 lead (1), circuit 22 lead (2), circuit 23 lead (3), circuit 24 lead (4), and circuit 451 lead (5) through opening in floor transverse beam (6).
48. Install clamp (7) on rear main wiring harness (8). Secure clamp and trailer wiring harness ground lead (9) on weldnut (10) with two new lockwashers (11) and screw (12).
49. Connect circuit 451 lead (5) to rear bilge pump (13).
50. Connect circuit 21 lead (1), circuit 22 lead (2), circuit 23 lead (3), and circuit 24 lead (4) to trailer wiring harness (14).
51. Install clamp (15) on rear main wiring harness (8). Secure clamp with screw (16) and new locknut (17).
52. Install clamp (15) and rear main wiring harness (10) on transverse beam (6). Secure with two screws (18) and new locknuts (19).
53. Install clamp (20) on rear main wiring harness (8). Secure clamp on weldnut (21) with new lockwasher (22) and screw (23).

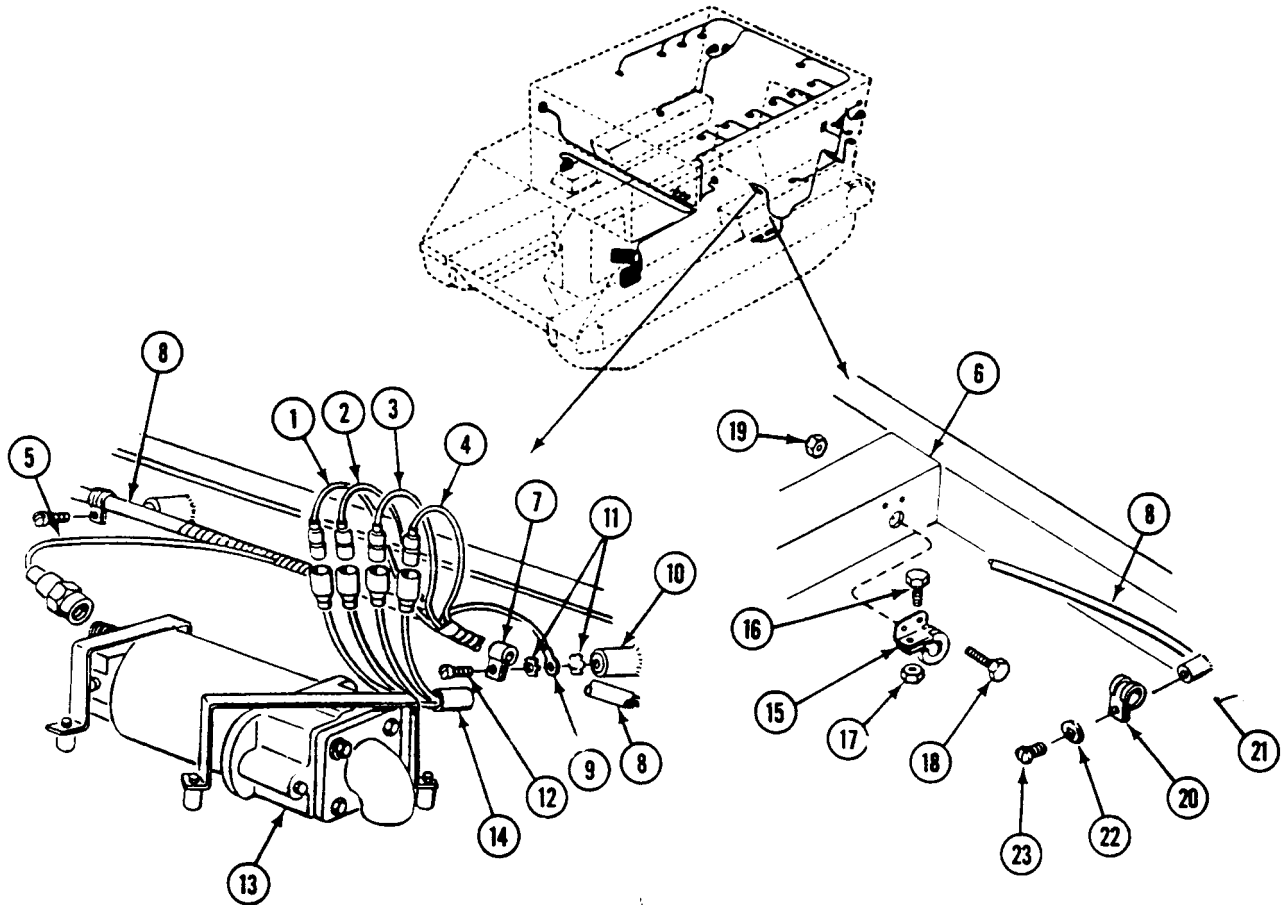

REPLACE REAR MAIN WIRING HARNESS (M1068A3 ONLY) — Continued

0365 00

54. Connect circuit 402 lead (1) to personnel heater fuel pump (2).
55. Install three clamps (3) on circuit 30 lead (4). Secure clamps and ground lead (5) on weldnuts (6) with new lockwashers (7) and screws (8).
56. Install ground lead (5) on left fuel quantity sending unit (9). Secure with screw (10), new lockwasher (11), and new lockwire (12).
57. Connect circuit 30 lead (4) on left sending unit (9).
58. Connect circuit 509 lead (13) to buzzer (14).
59. Install two clamps (15) on circuit 30 lead (4) and Circuit 509 lead (13). Secure clamps on two weldnuts (16) with one new lockwasher (17) and two screws (18).
60. Install rear main wiring harness (19) on seven weldnuts. Secure with seven clamps (20), new lockwashers (21) and screws (24).
61. Connect circuit 509 and 509A connector (22) to buzzer switch (23).

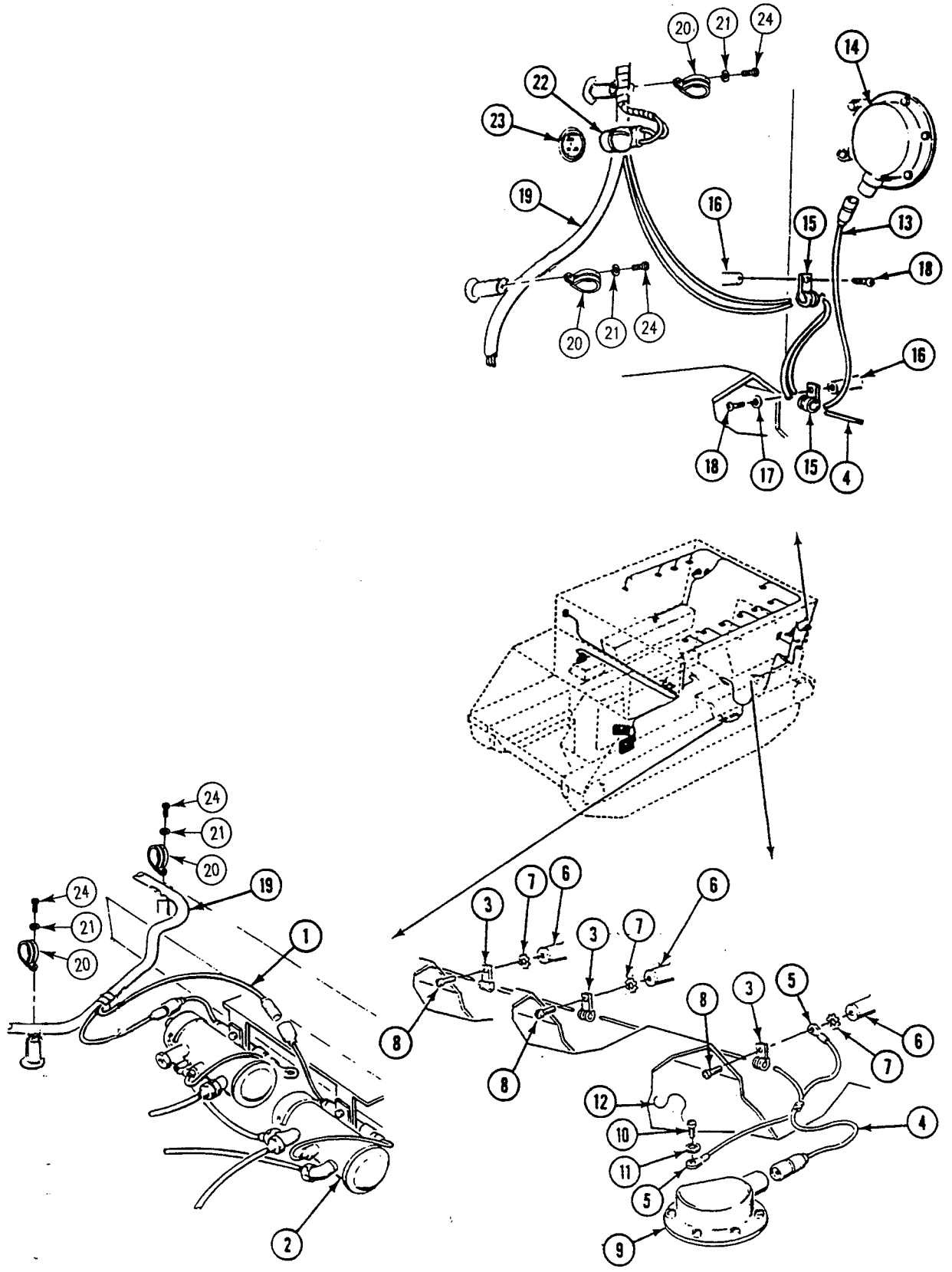

62. Connect circuit 38C lead (1) and circuit 38E lead (2) to blackout dome light switch (3).
63. Connect circuit 38 lead (4), circuit 38A lead (5), and circuit 38E lead (6) to dome light switch (7).
64. Connect circuit 21 lead (8), circuit 22 lead (9), and circuit 24 lead (10) to left tail light leads (11).
65. Connect circuit 37B lead (12) to left utility outlet lead (13).
66. Install two circuit 48 connectors (14) on bracket (15). Secure with eight screws (16) and new locknuts (17).
67. Install two ground leads (18) on weldnut (19). Secure with two new lockwashers (20) and screw (21).
68. Install rear main wiring harness (22) on seven weldnuts. Secure with seven clamps (23), new lockwashers (24) and screws (25).

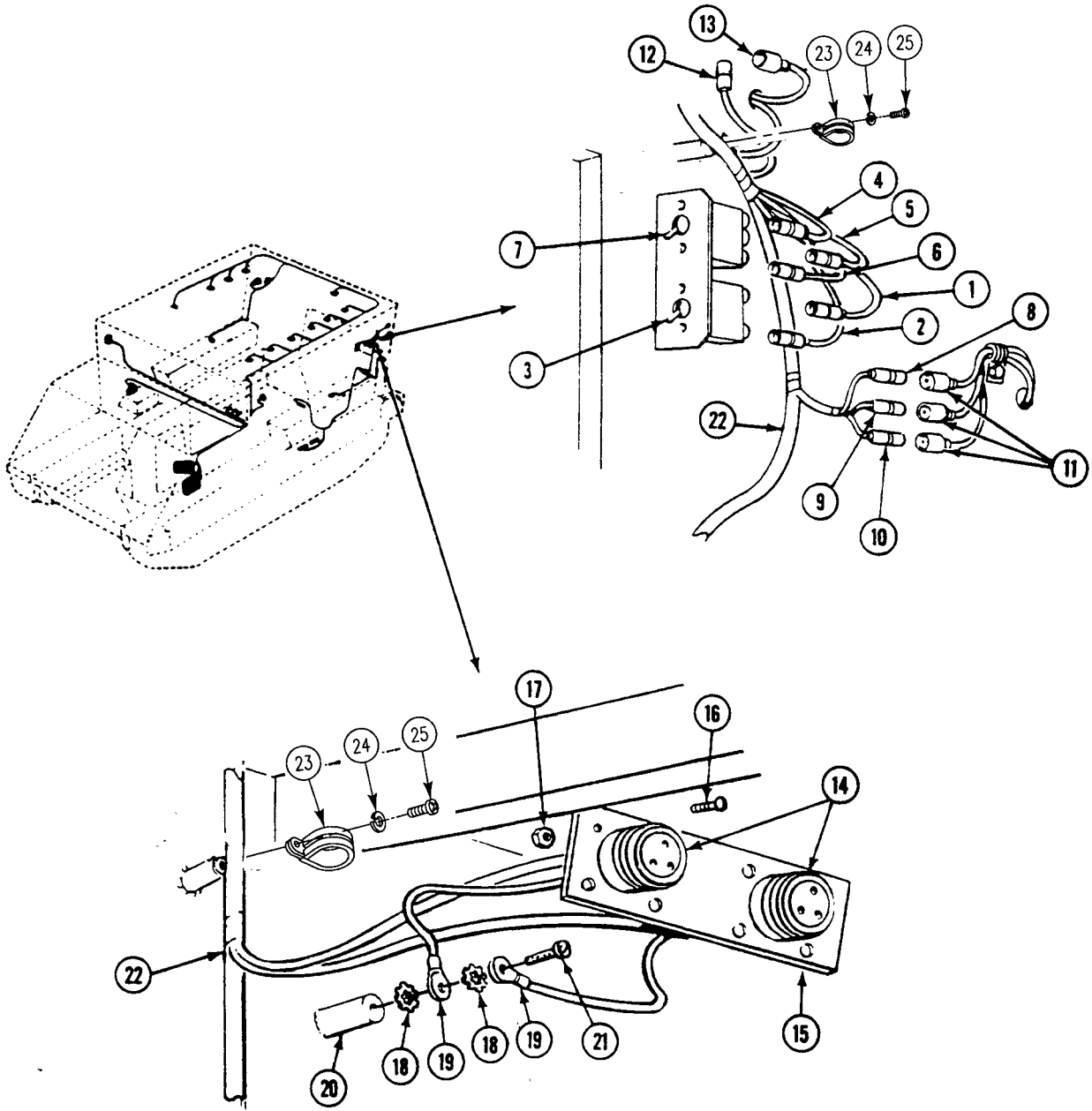

REPLACE REAR MAIN WIRING HARNESS (M1068A3 ONLY) — Continued

0365 00

69. Connect five circuit 38C leads (1) to five left side dome lights (2).
70. Install two clamps (3) on circuit 38B lead (4). Secure clamps and ground lead (5) on two weldnuts (6) with one new lockwasher (7) and two screws (8).
71. Connect circuit 38B lead (4) to rear blackout dome light (9).
72. Install rear main wiring harness (10) on six weldnuts. Secure with six clamps (11), new lockwashers (12) and screws (17).
73. Connect four circuit 38C leads (13) to four right side dome lights (14).
74. Install rear main wiring harness (10) on six weldnuts. Secure with six clamps (15), new lockwashers (16) and screws (18).

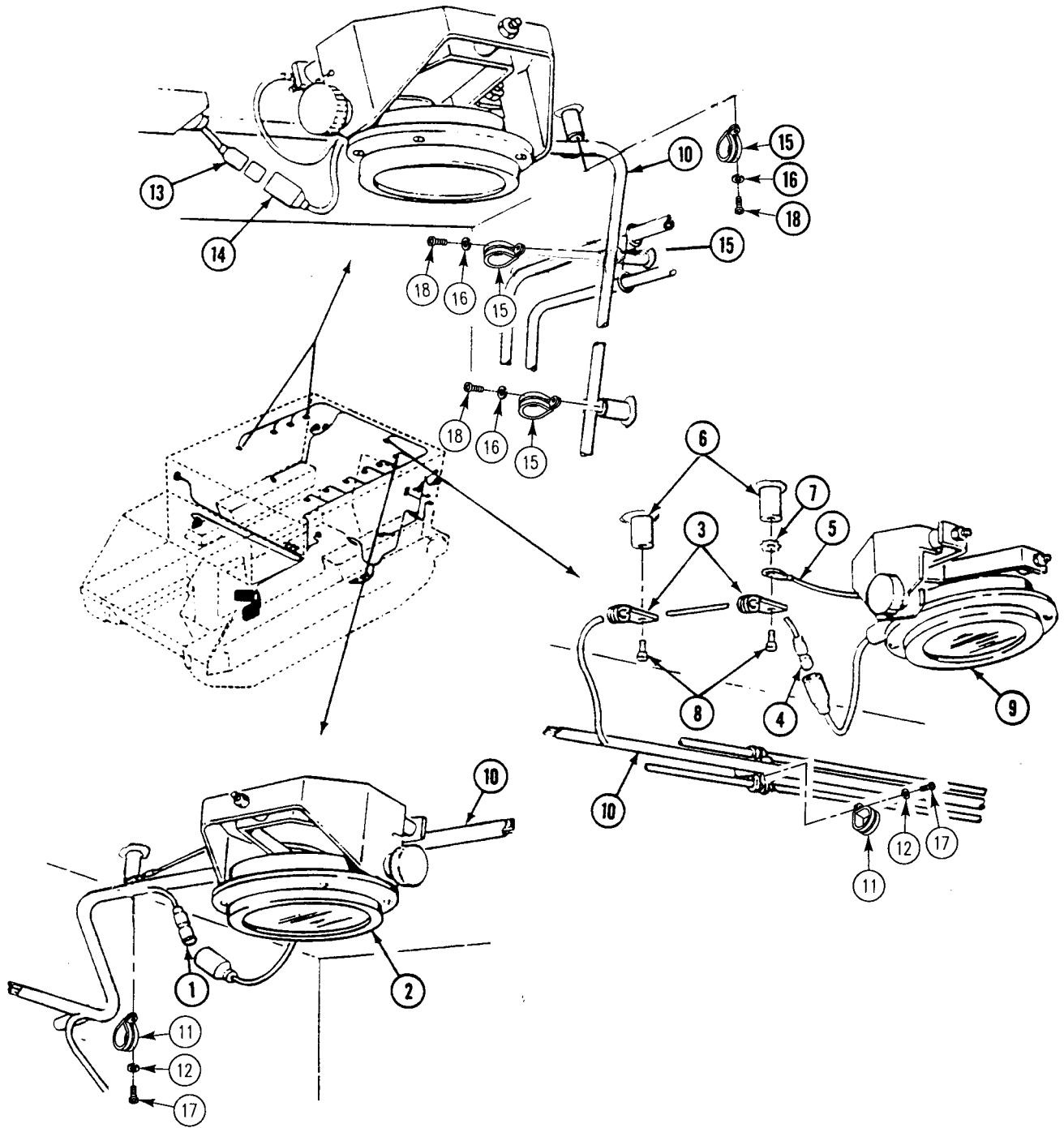

75. Connect circuit 37A lead (1) to right utility outlet lead (2).
76. If NBC unit is installed, connect circuit 415 lead (3) to NBC unit switch.
77. Connect circuit 23 lead (4) and circuit 24 lead (5) to right tail light (6).
78. Install four clamps (7) on circuit 29 lead (8). Secure ground lead (9) and clamps on three weldnuts (10) with two new lockwashers (11), three screws (12), and flat washers (13).
79. Install ground lead (9) on right fuel quantity sending unit (14). Secure with screw (15), new lockwasher (16), and new lockwire (17).
80. Connect circuit 29 lead (8) on right fuel quantity sending unit (14).

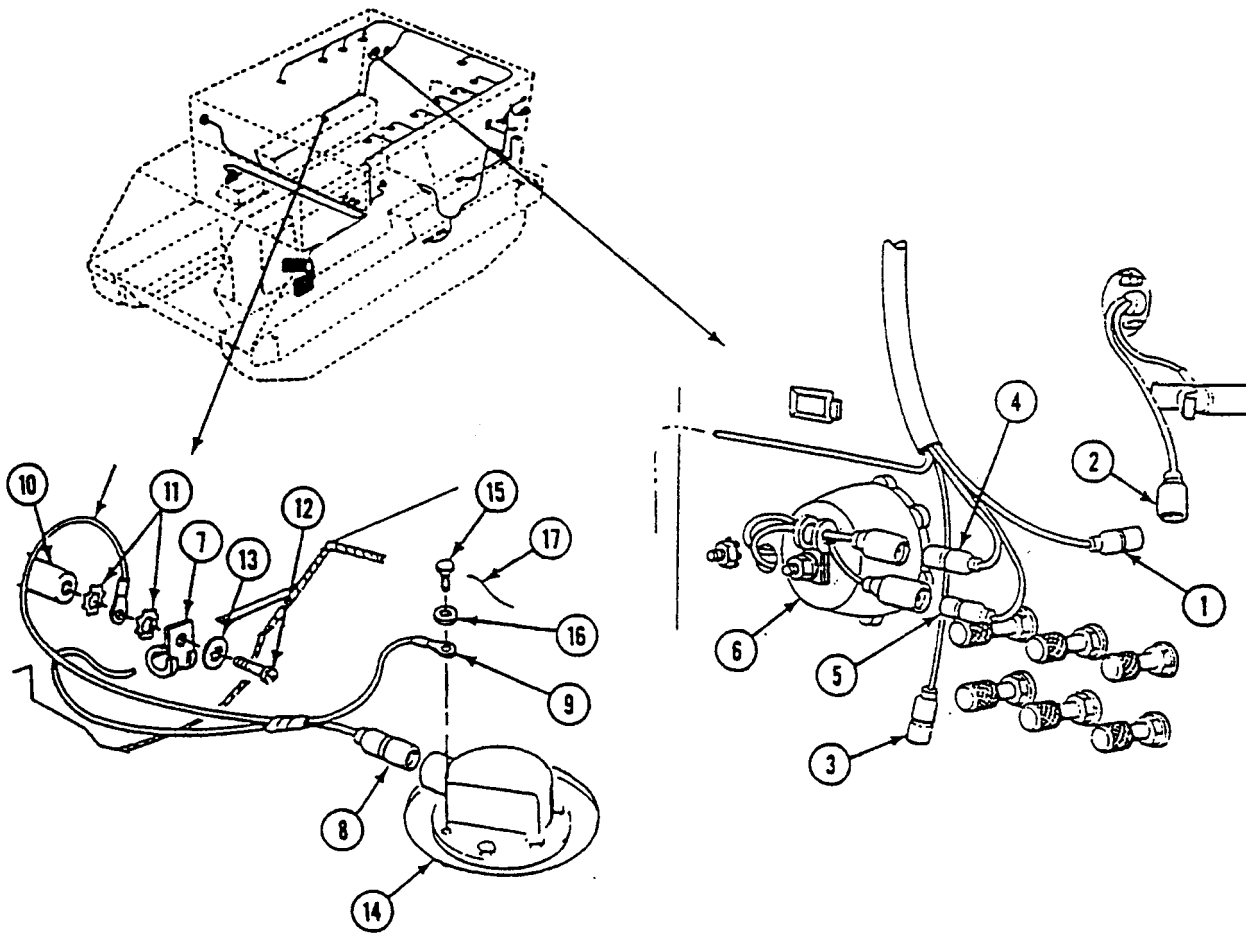

FOLLOW-THROUGH STEPS

1. Install rear floor plate (WP 0544 00).
2. Connect battery ground lead (WP 0338 00).
3. Install battery access cover (see your -10).
4. Turn MASTER SWITCH to ON (see your -10). Check that electrical system works properly.
5. Start engine (see your -10).
6. Raise and lock ramp (see your -10).
7. Stop engine (see your -10).

END OF TASK

REPLACE SMOKE GRENADE LAUNCHER WIRING HARNESS (M113A3, M1059A3, AND M58 ONLY)

0366 00 ■

THIS WORK PACKAGE COVERS:

- Removal (page 0366 00-1).
 - Inspection and Repair (page 0366 00-8).
 - Installation (page 0366 00-9).
-

INITIAL SETUP:

Maintenance Level

Unit

References

See your -10

Tools and Special Tools

General Mechanic's Tool Kit (WP 0926 00, Item 65)

Equipment Condition

- Engine stopped (see your -10)
- Carrier blocked (see your -10)
- Trim vane lowered (see your -10)
- Power plant front access door opened (see your -10)
- Ramp lowered (see your -10)
- Battery ground strap disconnected (WP 0337 00)
- Base and plate removed (WP 0455 00)

Materials/Parts

- Locknut (15)
- Lockwasher (19)

Personnel Required

- Unit Mechanic
 - Helper (H)
-

REPLACE SMOKE GRENADE LAUNCHER WIRING HARNESS (M113A3, M1059A3, AND M58 ONLY) — Continued

0366 00

REMOVAL

1. Disconnect circuit 7 (1) and circuit 799 lead (2) from inside carrier.
2. Disassemble lead (1) and lead (2) (WP 0382 00).
3. Remove nut (3), lockwasher (4), and washer (5) from bushing (6) and wiring harness (7). Discard lockwasher.
4. Remove packing retainer (8), spring washer (9), pressure washer (10), gasket (11), and plug (12) from bushing (6).
5. Remove nut (13), lockwasher (14), washer (15), and insulator washer (16) from bushing (6). Discard lockwasher.
6. Remove cover (17) from connector (18).
7. Repeat Steps 1 - 6 for opposite side of carrier.

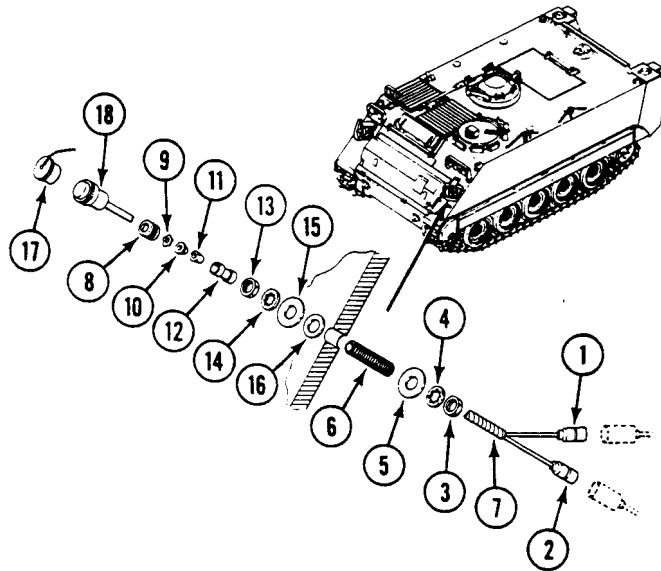

REPLACE SMOKE GRENADE LAUNCHER WIRING HARNESS (M113A3, M1059A3, AND M58 ONLY) — Continued

0366 00 ■

8. Remove screw (1), lockwasher (2), and clamp (3) from hull inside power plant compartment. Remove clamp from wiring harness (4). Discard lockwasher.
9. Remove two screws (5), lockwashers (6), clamps (7), and heater harness clamps (8) from hull. Remove clamps (7) from wiring harness (4). Discard lockwashers.

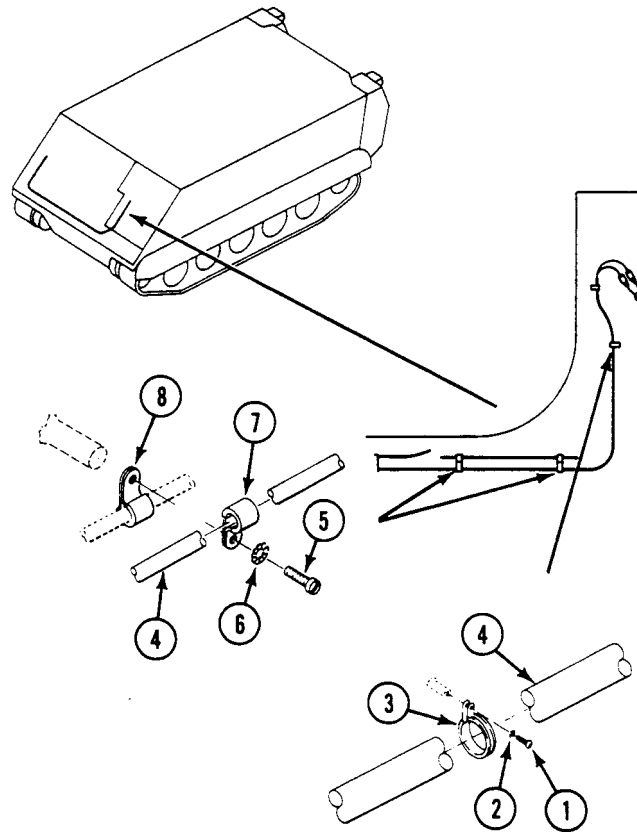

REPLACE SMOKE GRENADE LAUNCHER WIRING HARNESS (M113A3, M1059A3, AND M58 ONLY) — Continued

0366 00

10. Remove four screws (8), lockwashers (9), clamps (10), and clamps (11) from hull and bulkhead. Remove clamps (10) from wiring harness (12). Discard lockwashers.
11. Remove harness connector (13) from connector (14) on bulkhead.

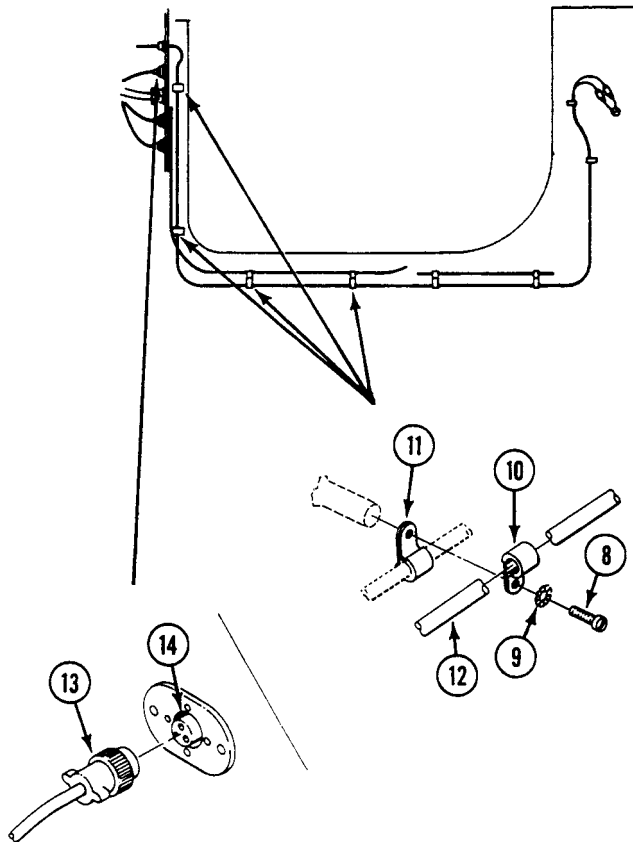

**REPLACE SMOKE GRENADE LAUNCHER WIRING HARNESS (M113A3,
M1059A3, AND M58 ONLY) — Continued**

0366 00 ■

12. Remove four locknuts (1), screws (2), washers (3), and harness connector (4) from driver's compartment bulkhead. Have helper assist. Discard locknuts.
13. Remove five screws (5), lockwashers (6), and clamps (7) from front hull inside driver's compartment. Remove clamps from wiring harness (8) and main wiring harness (4). Discard lockwashers.

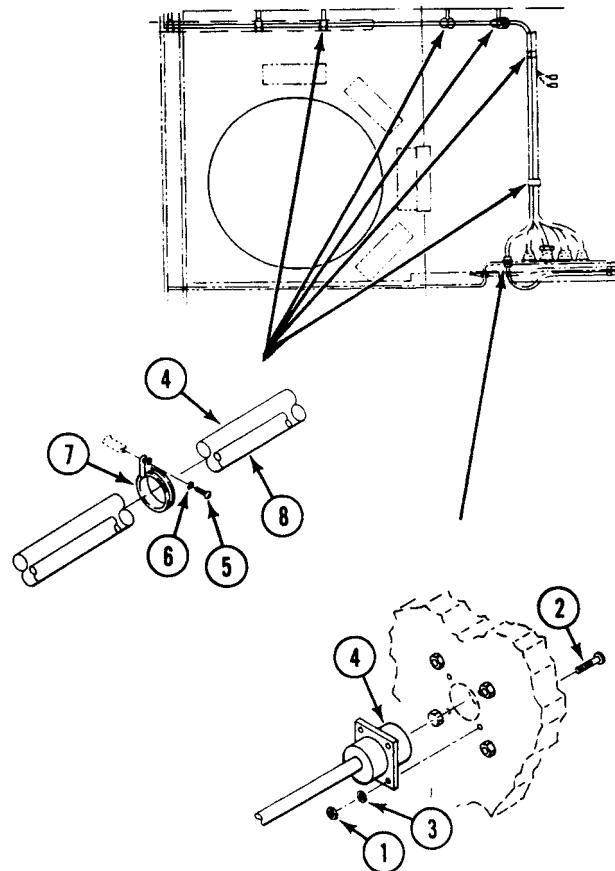

REPLACE SMOKE GRENADE LAUNCHER WIRING HARNESS (M113A3, M1059A3, AND M58 ONLY) — Continued

0366 00

14. Remove screw (10), lockwasher (11), clamp (12), and main wiring harness clamp (13) from hull. Remove clamps (12) from wiring harness (14). Discard lockwasher.
15. Remove screws (5), lockwasher (6), and clamp (7) from front hull inside driver's compartment. Remove clamp from wiring harness (8) and main wiring harness (4). Discard lockwasher.

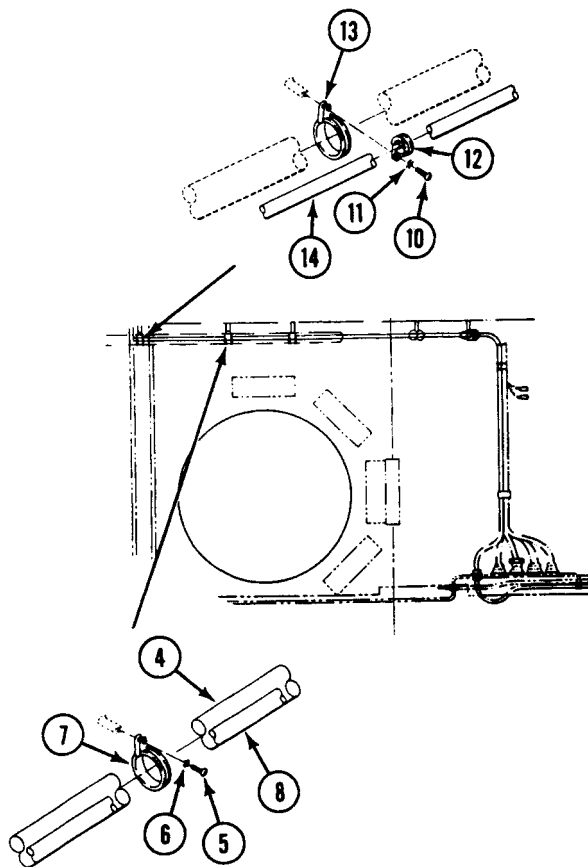

REPLACE SMOKE GRENADE LAUNCHER WIRING HARNESS (M113A3, M1059A3, AND M58 ONLY) — Continued

0366 00 ■

16. Remove eight locknuts (1), screws (2), washers (3), and master switch panel (4) from distribution box (5). Discard locknuts.
17. Remove screw (6), lockwasher (7), circuit 6L lead (8), and circuit 6 lead (9) from bus bar (10). Discard lockwasher.

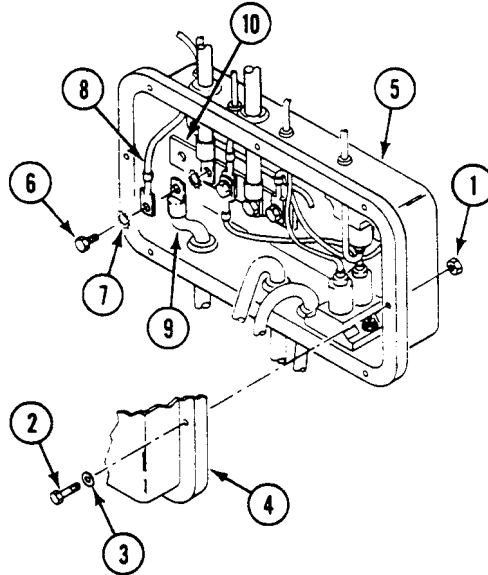

18. Remove three screws (11), lockwashers (12), and clamps (13) from bulkhead behind driver's compartment. Remove clamps from wiring harness (14) and intercom cable assembly (15). Discard lockwashers.

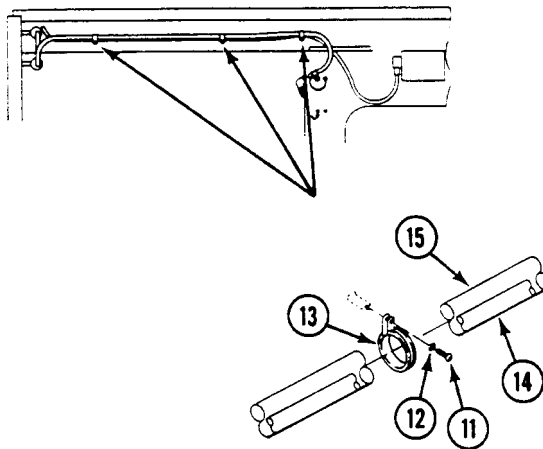

REPLACE SMOKE GRENADE LAUNCHER WIRING HARNESS (M113A3, M1059A3, AND M58 ONLY) — Continued

0366 00

19. Remove locknut (16), screw (17), two washers (18), and circuit 7 lead (19) from bulkhead. Discard locknut.
20. Remove locknut (20), screw (21), two washers (22), and clamp (23) from bulkhead. Remove clamp from wiring harness (24). Discard locknut.
21. Remove cover (25) with chain (26) from wiring harness (24).
22. Remove locknut (27), screw (28), two washers (29), and hook (30) from bulkhead. Discard locknut.
23. Remove all sections of wiring harness (24) from carrier.

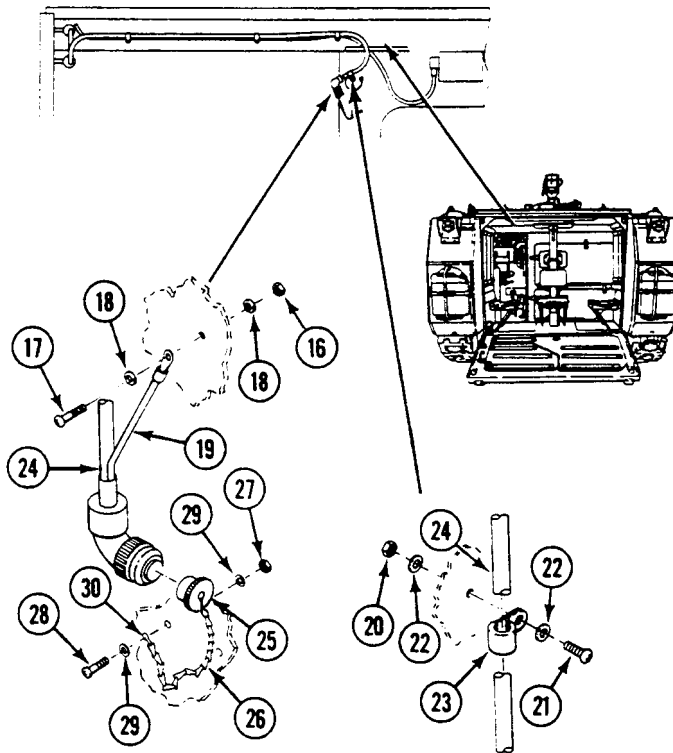

INSPECTION-ACCEPTANCE AND REJECTION CRITERIA

INSPECTION AND REPAIR

1. Inspect for damaged connectors or terminals. Repair as needed (WP 0382 00).

REPLACE SMOKE GRENADE LAUNCHER WIRING HARNESS (M113A3, M1059A3, AND M58 ONLY) — Continued

0366 00 ■

INSTALLATION

1. Install sections of wiring harness (1) in carrier.
2. Secure hook (2) to bulkhead with screw (3), two washers (4), and new locknut (5).
3. Install cover (6) with chain (7) on wiring harness (1).
4. Install clamp (8) on wiring harness (1). Secure clamp to bulkhead with screw (9), two washers (10), and new locknut (11).
5. Secure circuit 7 lead (12) to bulkhead with screw (13), two washers (14), and new locknut (15).

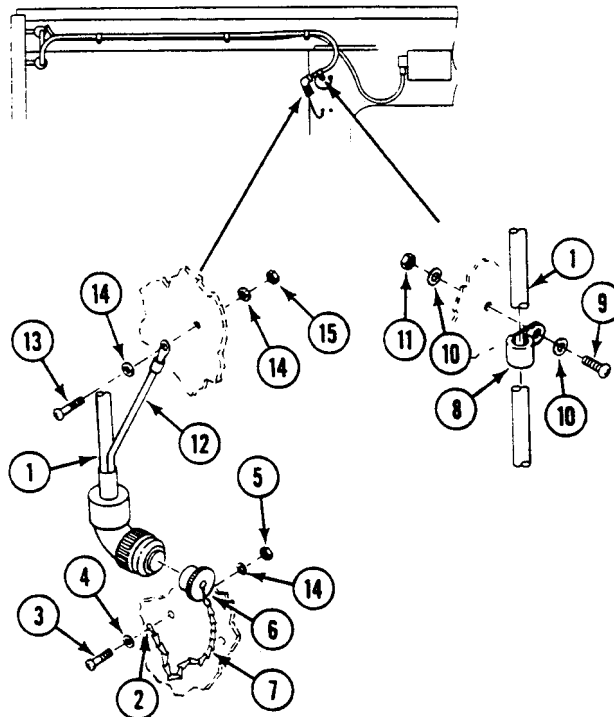

■ REPLACE SMOKE GRENADE LAUNCHER WIRING HARNESS (M113A3, M1059A3, AND M58 ONLY) — Continued

0366 00

6. Install three clamps on wiring harness (16) and intercom cable assembly (17). Secure clamps to bulkhead with three screws (18) and new lockwashers (19).

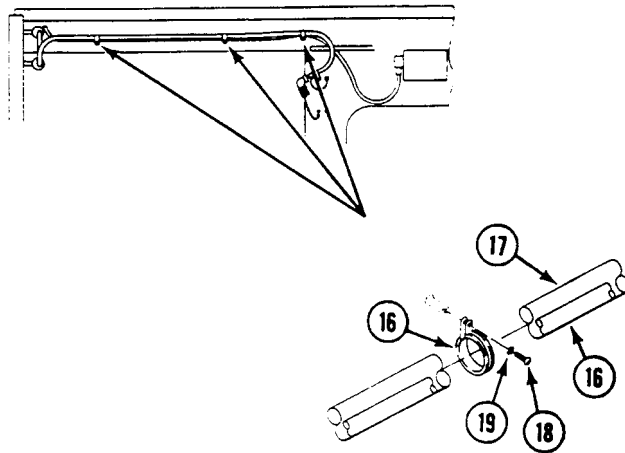

7. Install circuit 6L lead (20) and circuit 6 lead (21) on bus bar (22) of distribution box (23). Secure with screw (24) and new lockwasher (25).
8. Install master switch panel (26) on distribution box (23). Secure with eight screws (27), washers (28), and new locknuts (29).

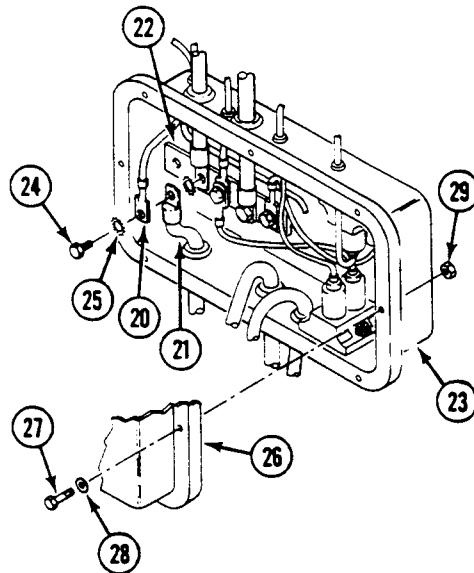

**REPLACE SMOKE GRENADE LAUNCHER WIRING HARNESS (M113A3,
M1059A3, AND M58 ONLY) — Continued**

0366 00 ■

9. Install clamp (9) on wiring harness (10) and main wiring harness (11). Secure clamp to hull with screw (12) and new lockwasher (13).
10. Install two clamps (5) on wiring harness (1). Secure clamps and main wiring harness clamp (6) to hull with two screws (7) and new lockwashers (8).

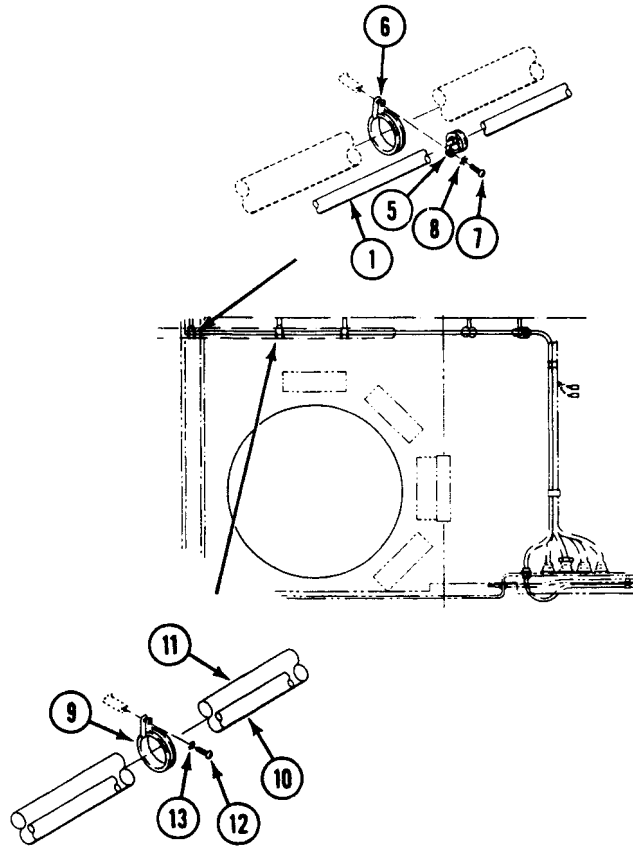

**REPLACE SMOKE GRENADE LAUNCHER WIRING HARNESS (M113A3,
M1059A3, AND M58 ONLY) — Continued**

0366 00

11. Install five clamps (9) on wiring harness (10) and main wiring harness (11). Secure clamps to hull with five screws (12) and new lockwashers (13).
12. Secure harness connector (14) to bulkhead with four screws (15), washers (16), and new locknuts (17).

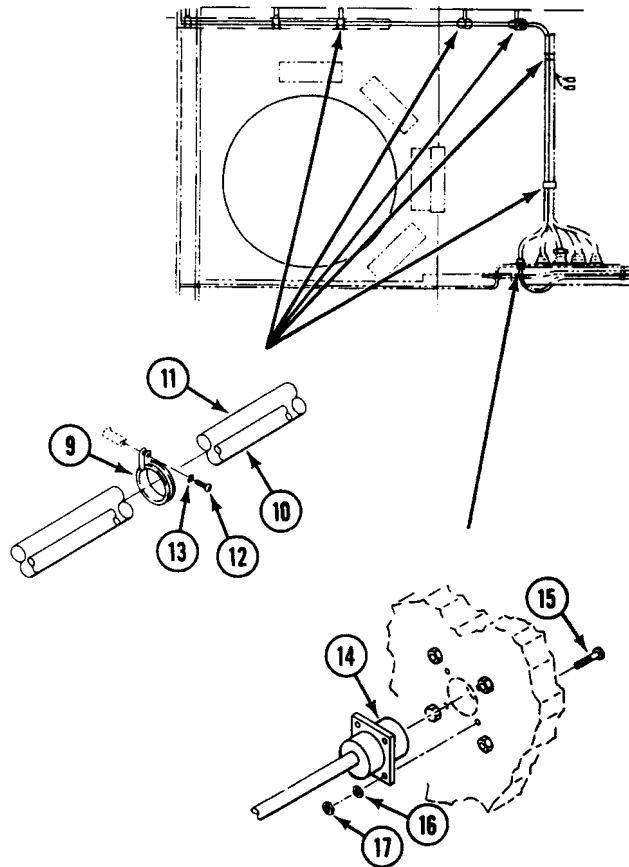

**REPLACE SMOKE GRENADE LAUNCHER WIRING HARNESS (M113A3,
M1059A3, AND M58 ONLY) — Continued**

0366 00 ■

13. Secure harness connector (1) to connector (2) on bulkhead.
14. Install four clamps (3) on wiring harness (4). Secure clamps and clamps (5) to hull and bulkhead with four screws (6) and new lockwashers (7).

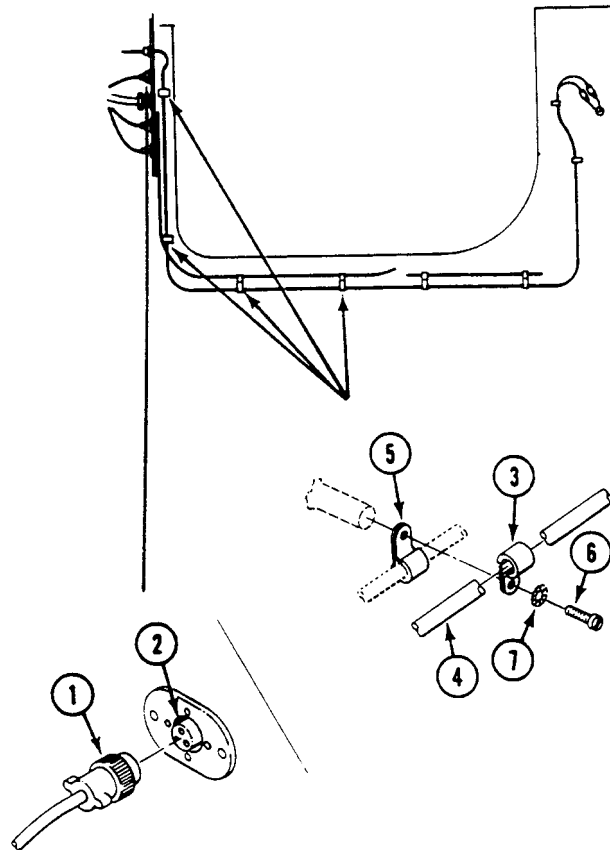

REPLACE SMOKE GRENADE LAUNCHER WIRING HARNESS (M113A3, M1059A3, AND M58 ONLY) — Continued

0366 00

15. Install two clamps (8) on wiring harness (9). Secure clamps and heater harness clamps (10) to hull with two screws (11) and new lockwashers (12).
16. Install clamp (13) on wiring harness (9). Secure clamp to hull with screw (14) and new lockwasher (15).

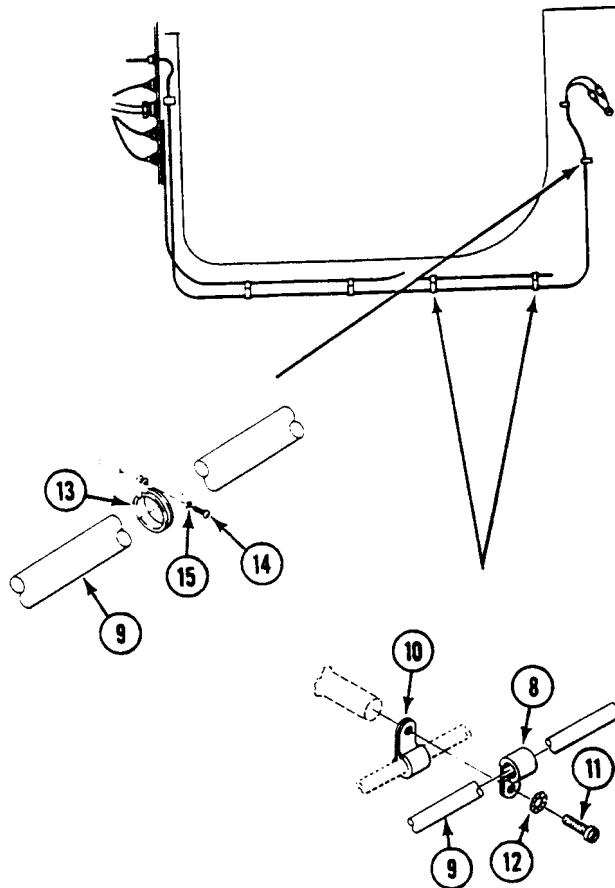

REPLACE SMOKE GRENADE LAUNCHER WIRING HARNESS (M113A3, M1059A3, AND M58 ONLY) — Continued

0366 00 ■

17. Install cover (1) on connector (2).
18. Install insulator washer (3), washer (4), new lock washer (5), and nut (6) on bushing (7).
19. Install plug (8), gasket (9), pressure washer (10), spring washer (11), and packing retainer (12) on bushing (7).
20. Install washer (13), new lock washer (14), and nut (15) on bushing (7) inside carrier.
21. Assemble lead (16) and (17). See (WP 0382 00).
22. Connect circuit 7 lead (16) and circuit 799 lead (17) inside carrier.

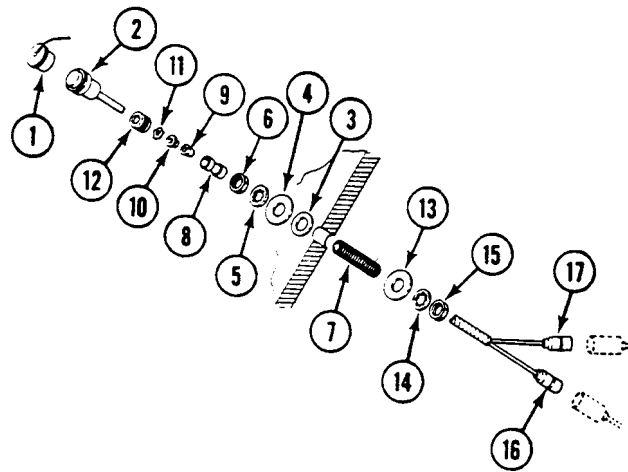

23. Repeat Steps 17 - 22 for opposite side of carrier.

FOLLOW-THROUGH STEPS

1. Install base and plate (WP 0455 00).
2. Close power plant front access door (see your -10).
3. Raise trim vane (see your -10).
4. Connect battery ground strap (WP 0337 00).
5. Start engine (see your -10).
6. Raise and lock ramp (see your -10).
7. Stop engine (see your -10).

END OF TASK

REPLACE STEERING LOCK SWITCH WIRING HARNESS (ALL EXCEPT M58)

0367 00

THIS WORK PACKAGE COVERS:

- Removal (page 0367 00-2).
 - Inspect and Repair (page 0367 00-5).
 - Installation (page 0367 00-6).
-

INITIAL SETUP:

Maintenance Level

Unit

References

See your -10

Tools and Special Tools

- General Mechanic's Tool Kit (WP 0926 00, Item 65)
- Multimeter (WP 0926 00, Item 30)

Materials/Parts

- Grommet
- Locknut (3)
- Strap

Equipment Condition

- Engine stopped (see your -10)
- Carrier blocked (see your -10)

Personnel Required

Unit Mechanic

Battery ground strap disconnected (WP 0337 00),
(WP 0338 00) or (WP 0339 00)

REPLACE STEERING LOCK SWITCH WIRING HARNESS (ALL EXCEPT M58) —
Continued

0367 00

REMOVAL

1. Disconnect circuit leads 369 and 369A (used on solenoid-activated lock) or leads 369A and 368 (used on cable-activated lock) (1) and (2) from steering locked indicator switch (3).

NOTE

Do Step 2 for solenoid-activated lock only.

2. Remove two nuts (4), lockwashers (5), circuit 368A lead (6), and ground lead (7) from solenoid terminals (8). Do not discard lockwashers.
3. Remove strap (9) securing wiring harness (10) in the steering wheel housing.

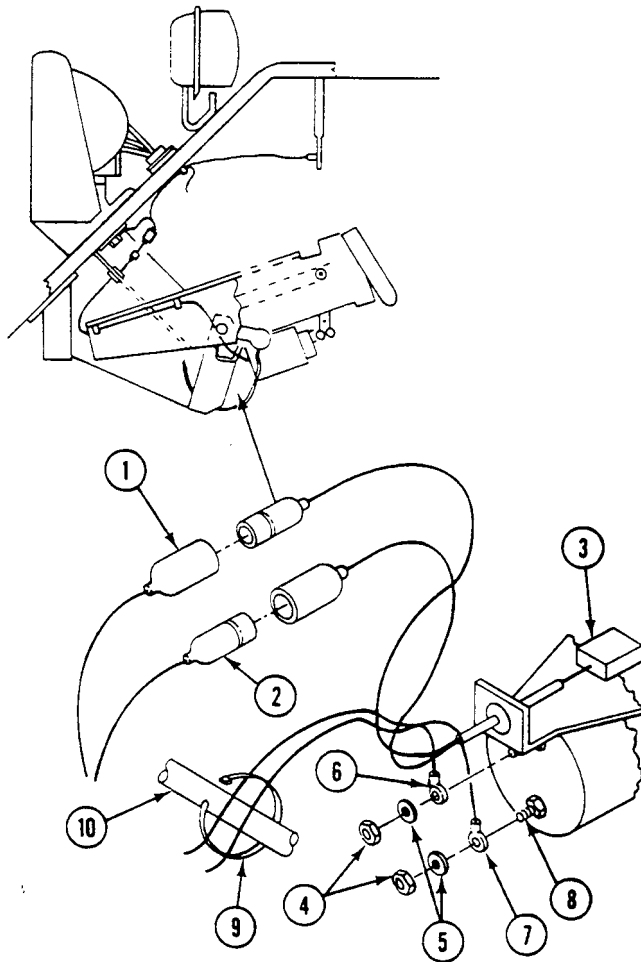

REPLACE STEERING LOCK SWITCH WIRING HARNESS (ALL EXCEPT M58) —
Continued

0367 00

4. Remove two screws (1), washers (2), clamps (3), and locknuts (4) from support (5). Remove wiring harness (6) from clamps. Discard locknuts.

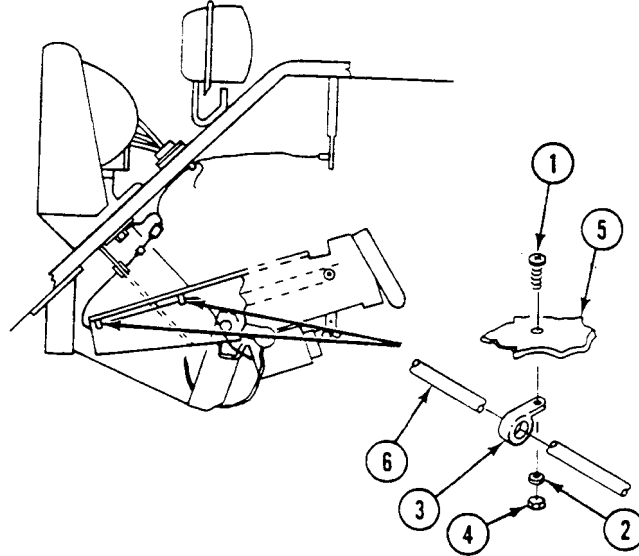

**REPLACE STEERING LOCK SWITCH WIRING HARNESS (ALL EXCEPT M58) —
Continued****0367 00**

5. Remove screw (7), washer (8), clamp (9), and locknut (10) from bracket (11). Remove wiring harness (6) from clamps. Discard locknut.

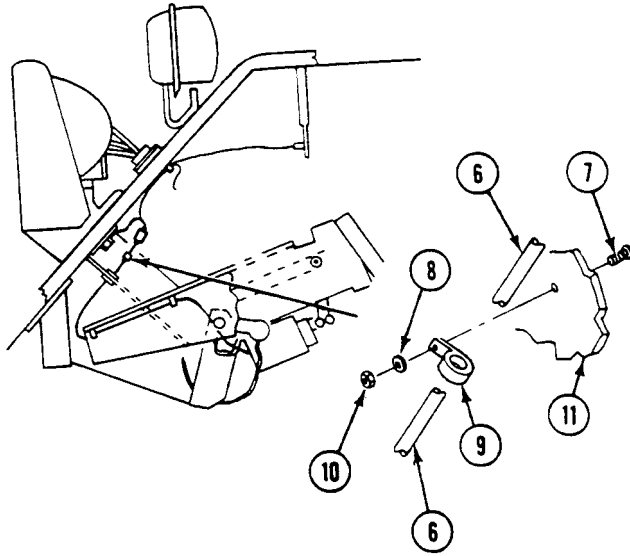

REPLACE STEERING LOCK SWITCH WIRING HARNESS (ALL EXCEPT M58) —
Continued

0367 00

6. Disconnect wiring harness connector (12) from connector (13).
7. Remove grommet (14) and wiring harness assembly (6) from bracket (15).
8. Remove wiring harness assembly (6) from carrier.

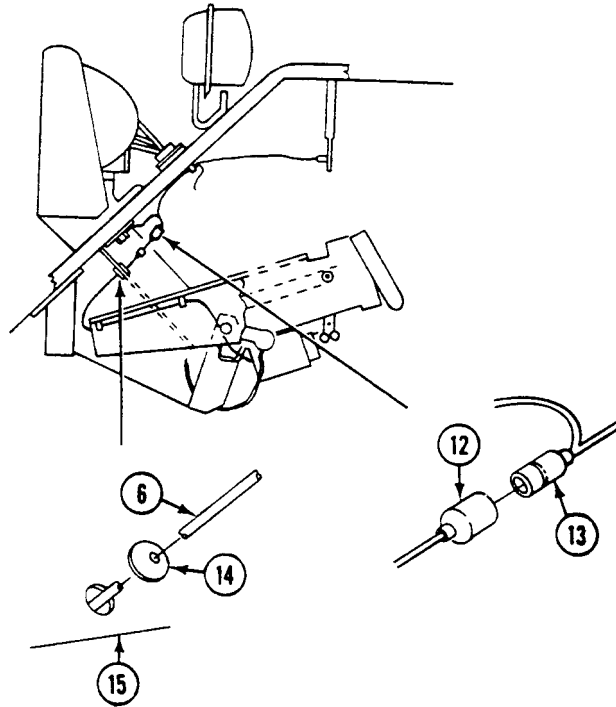
**TEST AND INSPECTION****INSPECT AND REPAIR**

1. Check harness for continuity. Replace bad harness.
2. Check leads. Replace frayed, cracked, or broken leads (WP 0382 00).
3. Check connectors. Replace cracked or broken connectors (WP 0382 00).

**REPLACE STEERING LOCK SWITCH WIRING HARNESS (ALL EXCEPT M58) —
Continued**

0367 00

INSTALLATION

1. Place wiring harness assembly (1) in carrier.
2. Install new grommet (2) and wiring harness assembly (1) on bracket (3).
3. Connect wiring harness connector (4) to connector (5).

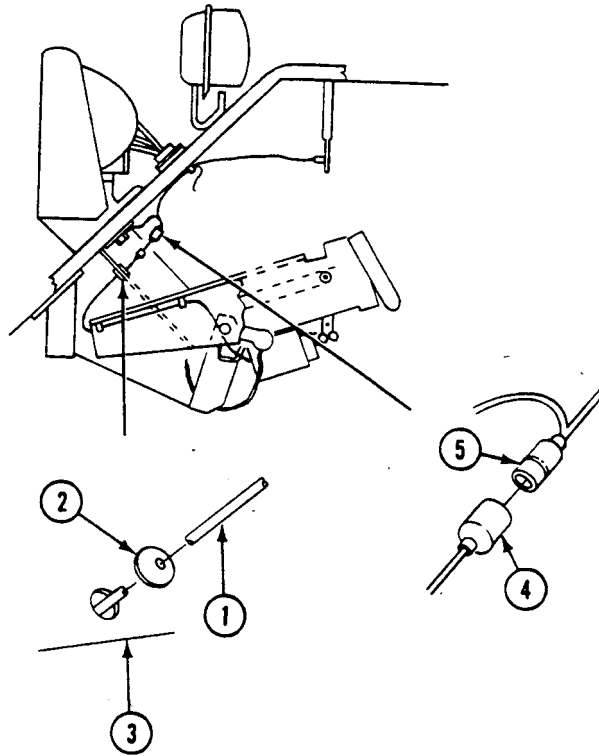

4. Install wiring harness (1) in clamp (6). Secure clamp to bracket (7) with screw (8), washer (9), and new locknut (10).

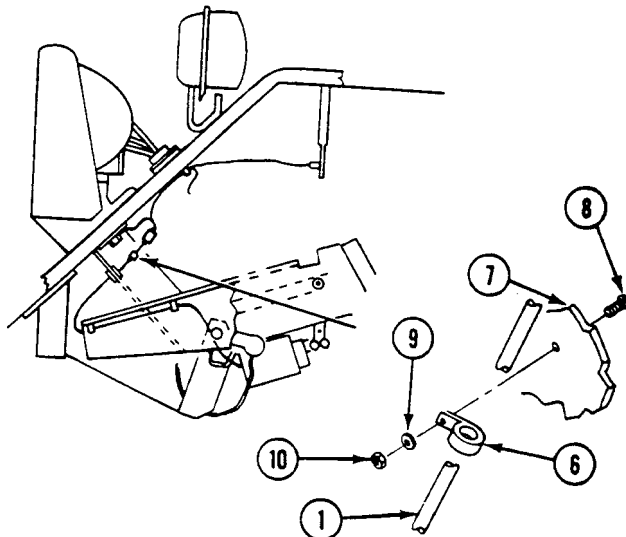

REPLACE STEERING LOCK SWITCH WIRING HARNESS (ALL EXCEPT M58) —
Continued

0367 00

5. Install wiring harness (1) in two clamps (11). Secure clamps to support (12) with two screws (13), washers (14), and new locknuts (15).

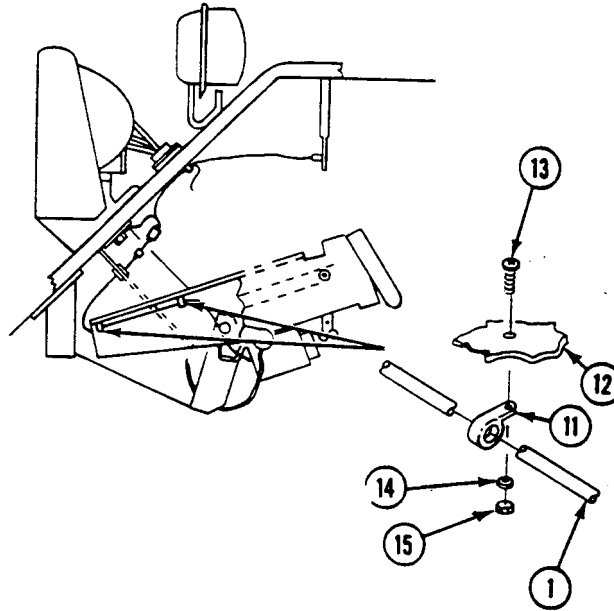

**REPLACE STEERING LOCK SWITCH WIRING HARNESS (ALL EXCEPT M58) —
Continued**

0367 00

- Install wiring harness (1) on bracket (2). Secure with strap (3).

NOTE

Do Step 7 for solenoid-activated lock only.

- Install circuit 368A lead (4), ground lead (5), two nuts (6) and lockwashers (7) on solenoid terminals (8).
- Connect circuit leads 369 and 369A (used on solenoid-activated lock) or leads 369A and 368 (used on cable-activated lock) (9) and (10) to steering locked indicator switch (11).

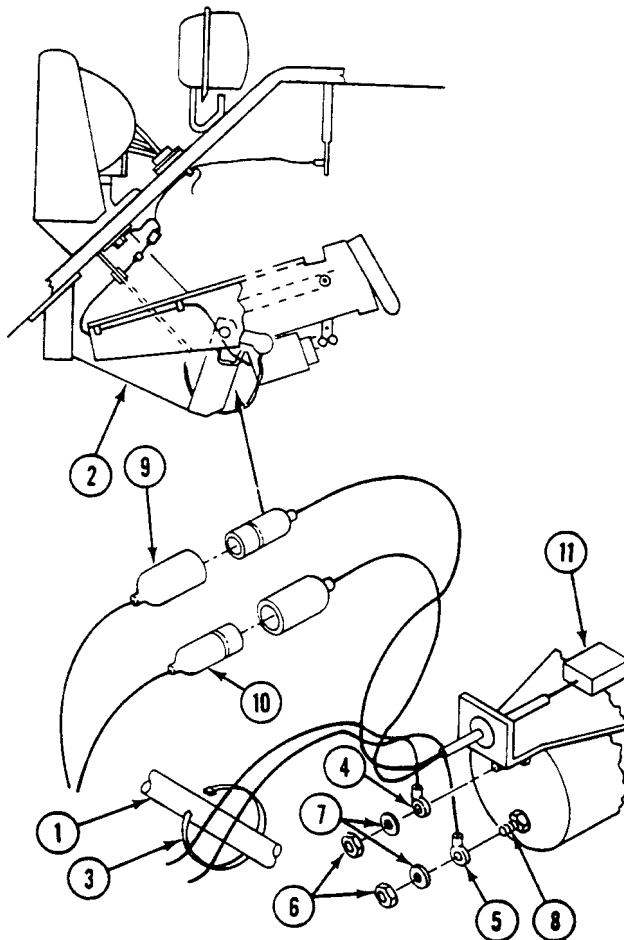
FOLLOW-THROUGH STEPS

- Connect battery ground strap (WP 0337 00), (WP 0338 00) or (WP 0339 00).
- Turn MASTER SWITCH to ON (see your -10).
- Place transmission controller in SL position. Check that steering wheel is locked and that STEERING LOCKED indicator is on (see your -10).
- Turn MASTER SWITCH to OFF (see your -10).

END OF TASK

REPLACE STEERING LOCK SWITCH WIRING HARNESS (M58 ONLY)

0367 01

THIS WORK PACKAGE COVERS:

- Removal (page 0367 01-1).
- Inspect and Repair (page 0367 01-2).
- Installation (page 0367 01-2).

INITIAL SETUP:

Maintenance Level

Unit

References

See your -10

Tools and Special Tools

- General Mechanic's Tool Kit (WP 0926 00, Item 65)
- Multimeter (WP 0926 00, Item 30)

Equipment Condition

- Engine stopped (see your -10)
- Carrier blocked (see your -10)
- Battery ground strap disconnected (WP 0337 00), (WP 0338 00), or (WP 0339 00)

Materials/Parts

- Grommet
- Locknut (3)
- Strap

Personnel Required

Unit Mechanic

REMOVAL

1. Disconnect circuit leads 369 and 369A (used on solenoid-activated lock) or leads 369A and 368 (used on cable-activated lock) (1) and (2) from steering locked indicator switch (3).

NOTE

Do Step 2 for solenoid-activated lock only.

2. Remove two nuts (8), lockwashers (7), circuit 368A lead (5), and ground lead (6) from solenoid terminals (4). Do not discard lockwashers.
3. Remove strap (9) securing wiring harness (10) in the steering wheel housing.

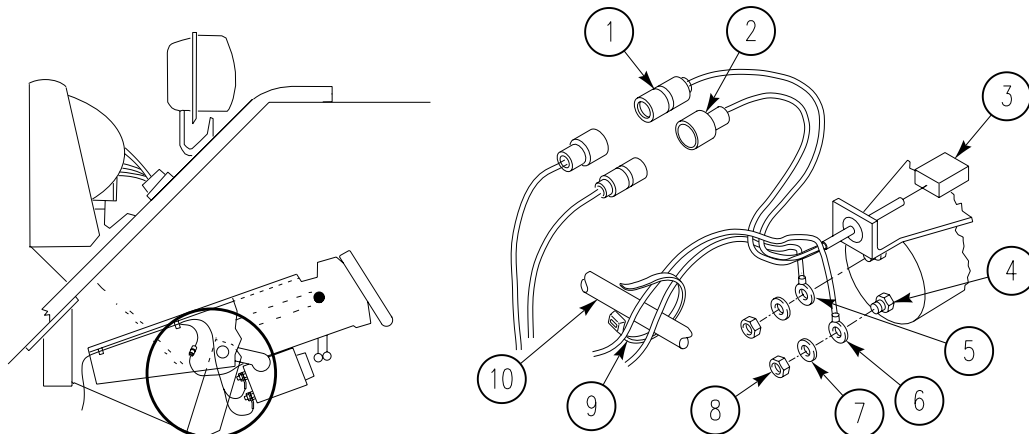

REPLACE STEERING LOCK SWITCH WIRING HARNESS (M58 ONLY) — Continued

0367 01

- Remove two screws (1), washers (3), clamps (2), and locknuts (4) from support (6). Remove wiring harness (5) from clamps. Discard locknuts.

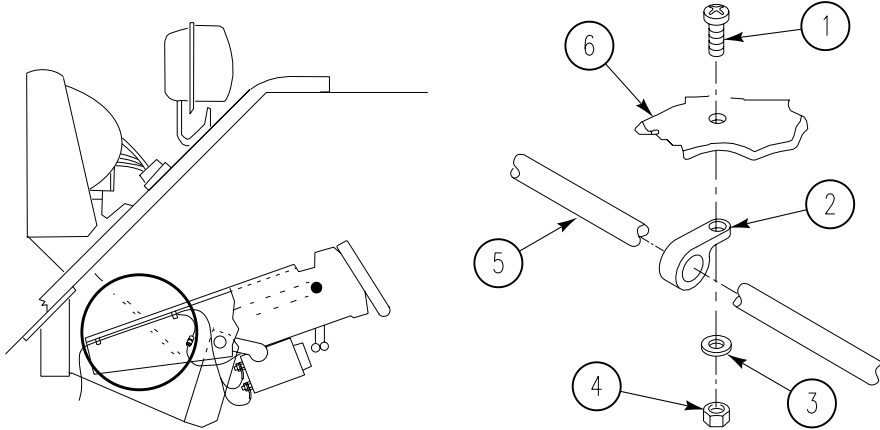

TEST AND INSPECTION

INSPECT AND REPAIR

- Check harness for continuity. Replace bad harness.
- Check leads. Replace frayed, cracked, or broken leads (WP 0382 00).
- Check connectors. Replace cracked or broken connectors (WP 0382 00).

INSTALLATION

- Install wiring harness (5) in two clamps (2). Secure clamps to support (6) with two screws (1), washers (3), and new locknuts (4).

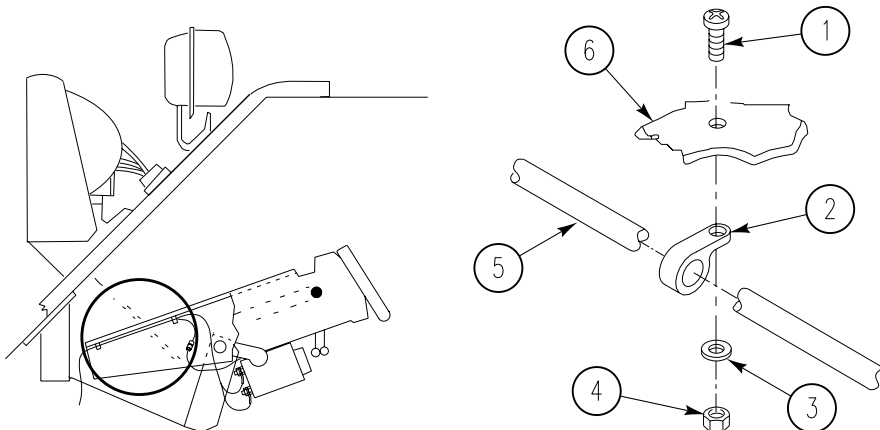

2. Install wiring harness (1) on bracket (12). Secure with strap (3).

NOTE

Do Step 3 for solenoid-activated lock only.

3. Install circuit 368A lead (5), ground lead (6), two nuts (8) and lockwashers (7) on solenoid terminals (4).
4. Connect circuit leads 369 and 369A (used on solenoid-activated lock) or leads 369A and 368 (used on cable-activated lock) (1) and (2) to steering locked indicator switch (3).

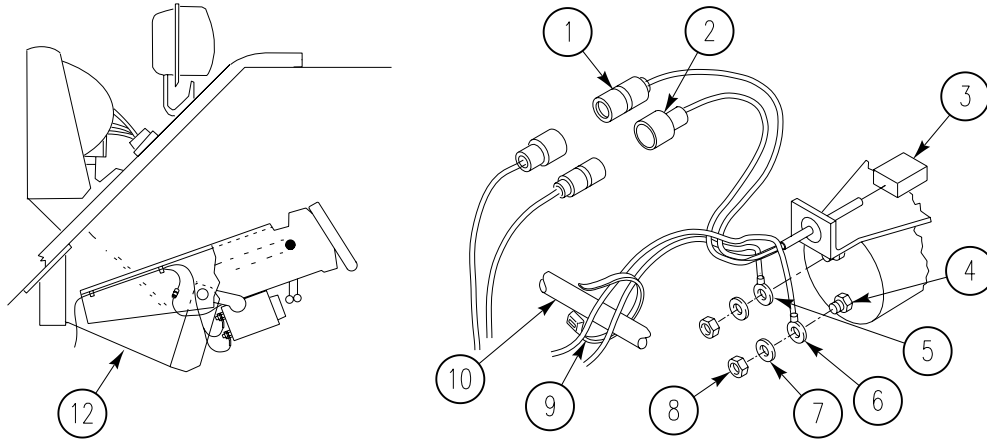
**FOLLOW-THROUGH STEPS**

1. Connect battery ground strap (WP 0337 00), (WP 0338 00), or (WP 0339 00).
2. Turn MASTER SWITCH to ON (see your -10).
3. Place transmission controller in SL position. Check that steering wheel is locked and that STEERING LOCKED indicator is on (see your -10).
4. Turn MASTER SWITCH to OFF (see your -10).

END OF TASK

**REPLACE DRIVER'S NIGHT VISION (DNV) (AN/VVS-2) POWER SUPPLY
CABLE ASSEMBLY (ALL EXCEPT M58)**

0368 00

THIS WORK PACKAGE COVERS:

Removal (page 0368 00-1).
Installation (page 0368 00-3).

INITIAL SETUP:

Maintenance Level

Unit

References

See your -10

Tools and Special Tools

General Mechanic's Tool Kit (WP 0926 00, Item 65)

Equipment Condition

Engine stopped (see your -10)
Carrier blocked (see your -10)
DNV POWER switch OFF
Battery ground strap disconnected (WP 0337 00),
(WP 0338 00), or (WP 0339 00)

Personnel Required

Unit Mechanic

REMOVAL

WARNING



High voltage in the AN/VVS-2 driver's night vision can cause serious injury or death. To avoid accidents:

ALWAYS connect power cable to periscope BEFORE turning MASTER SWITCH and DNV POWER switch ON.

After turning DNV. POWER and MASTER switches OFF, ALWAYS wait at least 2 minutes BEFORE disconnecting power cable from DNV. Do not disconnect power cable until image disappears from DNV screen.

NEVER touch the end of the cable or allow it to contact metal surfaces. Voltage could exceed 16,000 volts.

REPLACE DRIVER'S NIGHT VISION (DNV) (AN/VVS-2) POWER SUPPLY CABLE ASSEMBLY (ALL EXCEPT M58) — Continued

0368 00

1. If circuit 517 lead (1) is in stowed position, disconnect it from the master switch panel dummy connector (3).
2. If circuit 517 (1) is in operating position, disconnect it from the bottom of periscope (2).

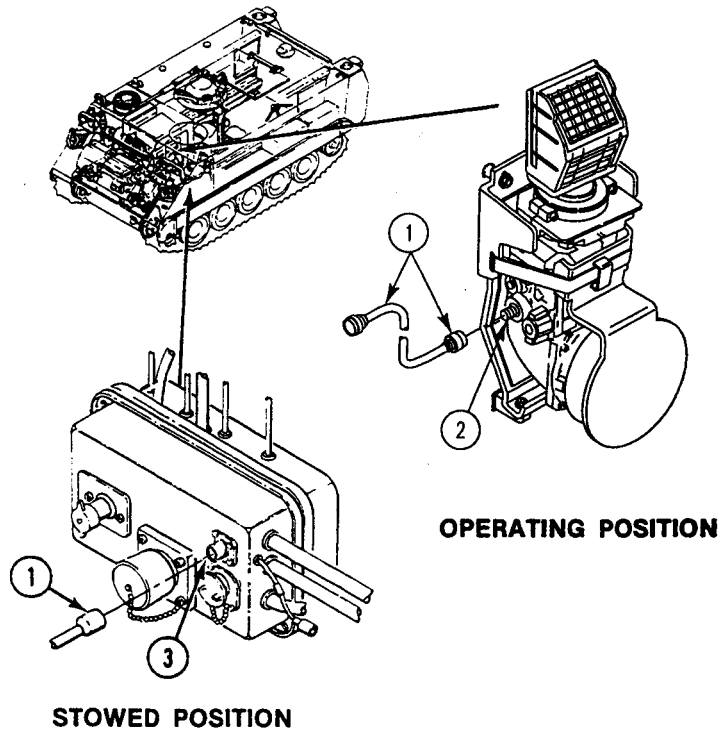

REPLACE DRIVER'S NIGHT VISION (DNV) (AN/VVS-2) POWER SUPPLY CABLE ASSEMBLY (ALL EXCEPT M58) — Continued

0368 00

INSTALLATION

1. For stowed position, connect circuit 517 lead (1) to the master switch panel dummy connector (3).
2. For operating position, connect circuit 517 lead (1) to the bottom of periscope (2).

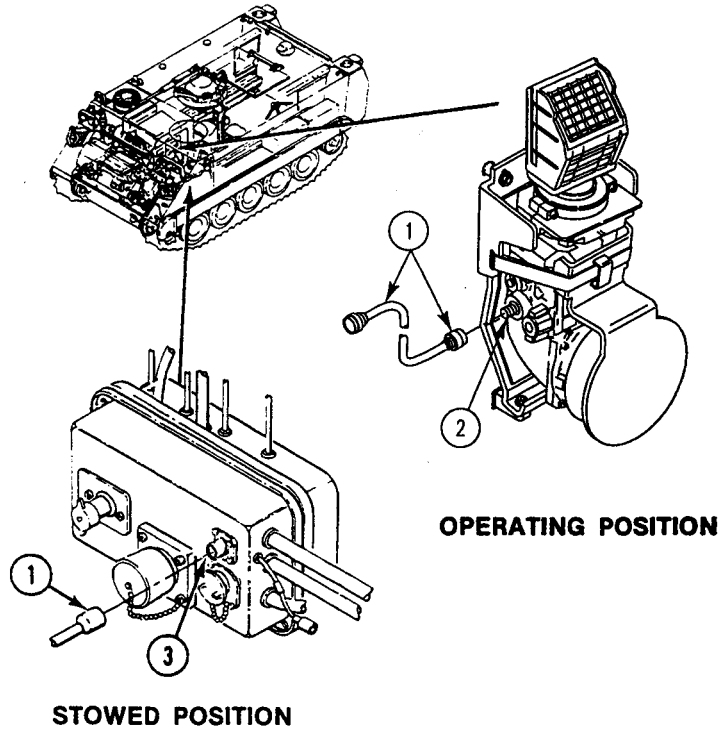

FOLLOW-THROUGH STEPS

1. Connect battery ground strap (WP 0337 00), (WP 0338 00), or (WP 0339 00).

END OF TASK

REPLACE BATTERY-TO-RADIO WIRING HARNESS (LEFT SIDE) (M113A3 AND M1059A3 ONLY)

0369 00 ■

THIS WORK PACKAGE COVERS:

- Removal (page 0369 00-2).
 - Inspect and Repair (page 0369 00-4).
 - Installation (page 0369 00-5).
-

INITIAL SETUP:

Maintenance Level

Unit

References

See your -10

Tools and Special Tools

General Mechanic's Tool Kit (WP 0926 00, Item 65)

Equipment Condition

Materials/Parts

- Grommet
- Locknut (8)
- Lockwasher
- Lockwasher (7)

- Engine stopped (see your -10)
- Carrier blocked (see your -10)
- Ramp lowered (see your -10)
- Spall liners opened (see your -10)
- Battery ground strap disconnected (WP 0337 00)
- Rear battery box cover removed (see your -10)

Personnel Required

Unit Mechanic

REPLACE BATTERY-TO-RADIO WIRING HARNESS (LEFT SIDE) (M113A3 AND M1059A3 ONLY) — Continued

0369 00

REMOVAL**NOTE**

On M113A3 only, there are two circuit 48 leads connected to positive terminal of third battery. Replace circuit 48 lead which runs along hull to capacitor located above battery boxes.

1. Remove nut (1), screw (2), positive jumper lead (3), circuit 772 lead (4), circuit 778 lead (5), circuit 48 lead (6), and M113A3 only circuit 48 lead (7) from positive terminal (8) of third battery (9).

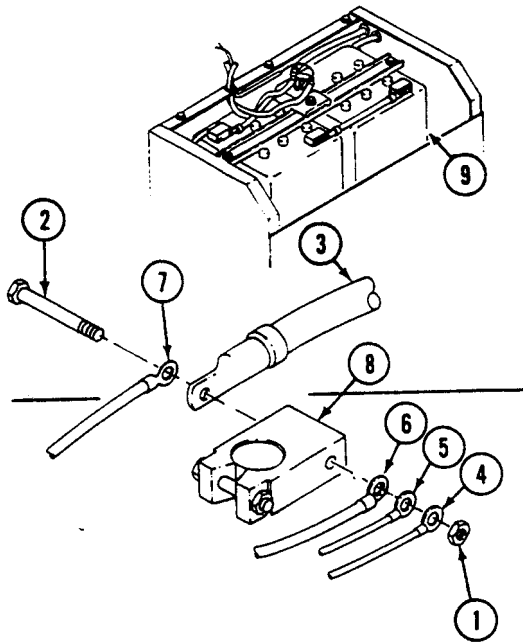

REPLACE BATTERY-TO-RADIO WIRING HARNESS (LEFT SIDE) (M113A3 AND M1059A3 ONLY) — Continued

0369 00 ■

2. Remove three leads (10) and grommet (11) from battery box (12). Discard grommet.
3. Remove four screws (13), lockwashers (14) and clamps (15) that secure circuit 48 lead (6) to hull. Remove leads from clamps. Discard lockwashers.

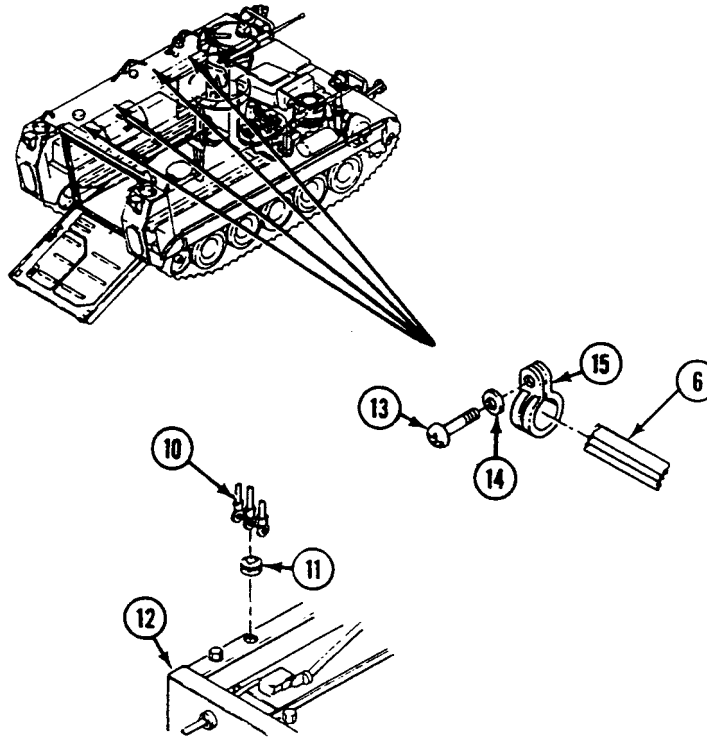

■ REPLACE BATTERY-TO-RADIO WIRING HARNESS (LEFT SIDE) (M113A3 AND M1059A3 ONLY) — Continued

0369 00

4. Remove screw (1), lockwasher (2), and circuit 48 lead (3) from capacitor (4). Discard lockwasher.
5. Remove screw (5), two lockwashers (6), capacitor (4), two ground leads (7)(8) and clamp (9) from hull. Remove clamp from circuit 48 lead. Discard lockwashers.
6. Remove cap (10) from receptacle (11).
7. Remove eight screws (12), locknuts (13), two receptacles (11), and cap chain (14) from bracket (15). Discard locknuts.

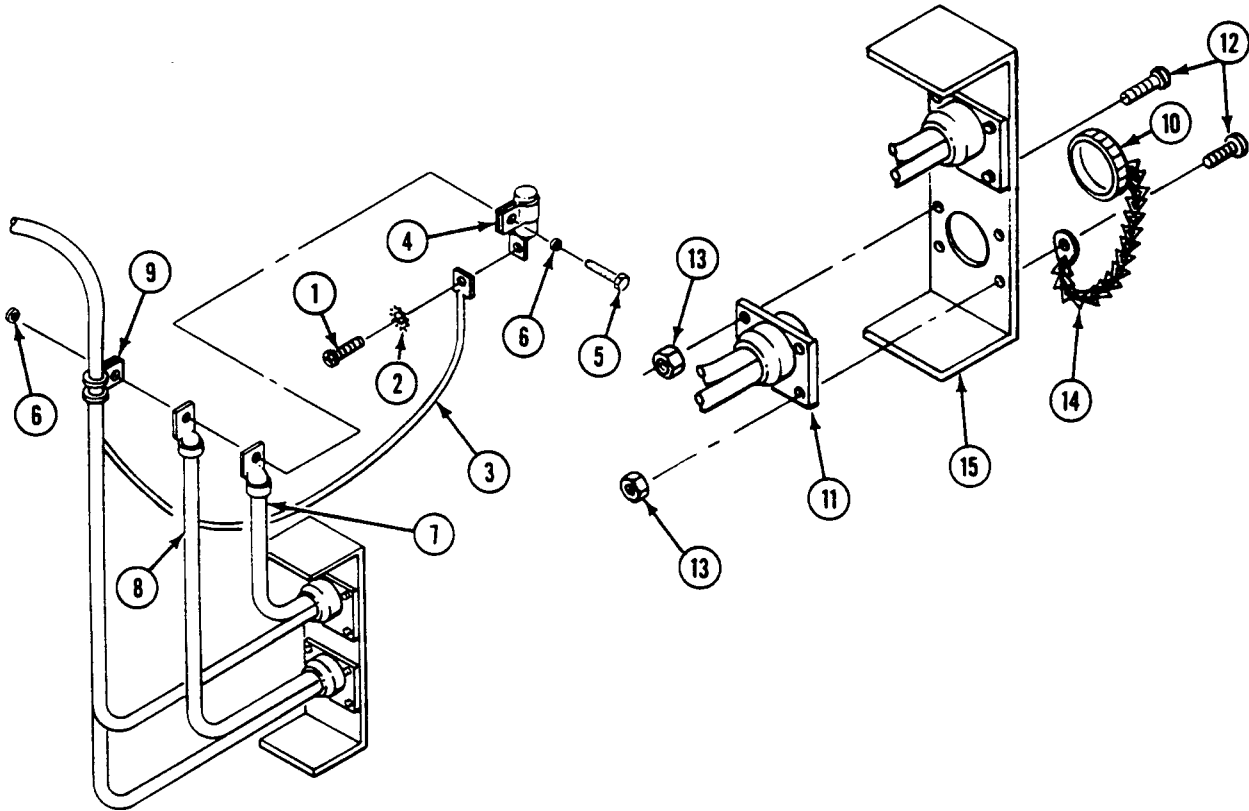

INSPECT AND REPAIR

1. Check for damaged connectors and terminals. Repair as needed (WP 0382 00).

REPLACE BATTERY-TO-RADIO WIRING HARNESS (LEFT SIDE) (M113A3 AND M1059A3 ONLY) — Continued

0369 00 ■

INSTALLATION

1. Install two receptacles (11) and cap chain (14) on bracket (15). Secure with eight screws (12) and new locknuts (13).
2. Install cap (10) on receptacle (11).
3. Install clamp (9) on circuit 48 lead (3). Then install clamp, two ground leads (7)(8), and capacitor (4) on hull. secure with screw (5) and two new lockwashers (6).
4. Install circuit 48 lead (3) on capacitor (4). Secure with screw (1) and new lockwasher (2).

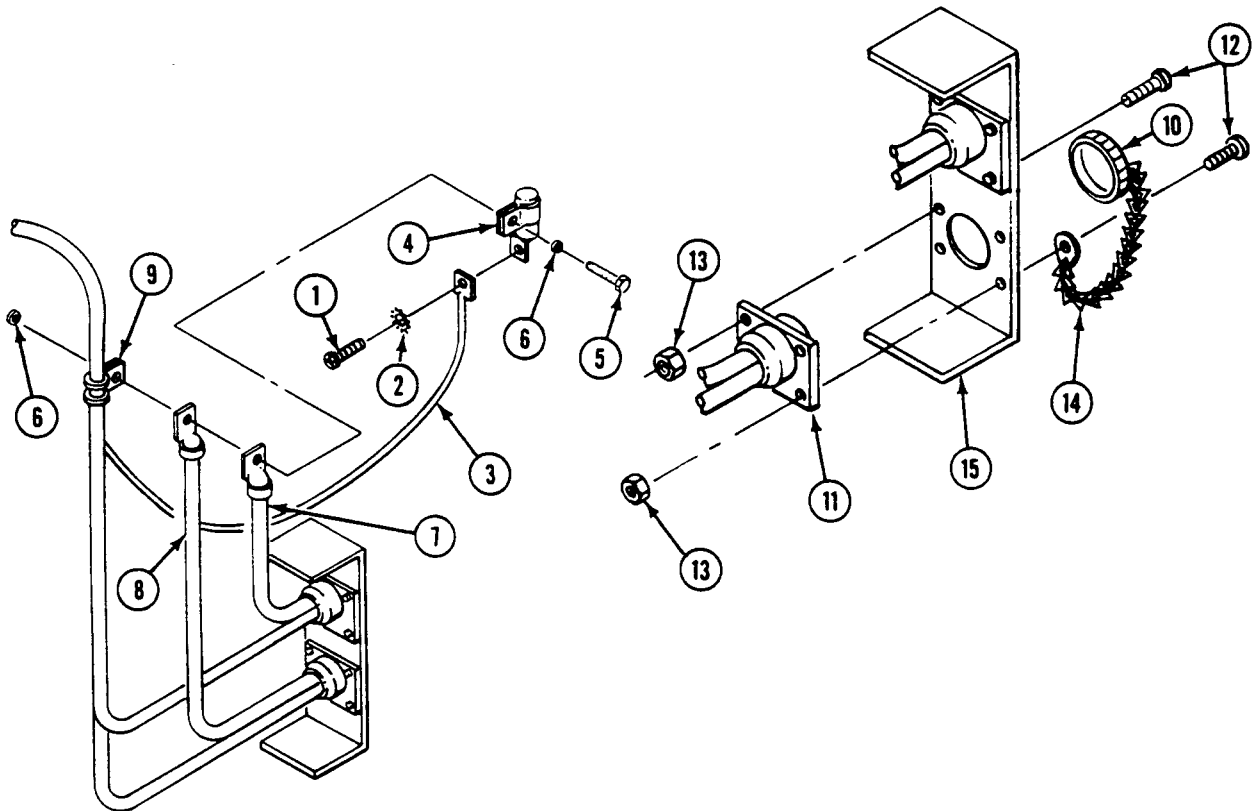

■ REPLACE BATTERY-TO-RADIO WIRING HARNESS (LEFT SIDE) (M113A3 AND M1059A3 ONLY) — Continued

0369 00

5. Install four clamps (1) on circuit 48 lead (2) and route along left side of hull. Secure with four screws (3) and new lockwashers (4).
6. Install new grommet (5) on three leads (6) and route into battery box (7). Secure grommet in box.

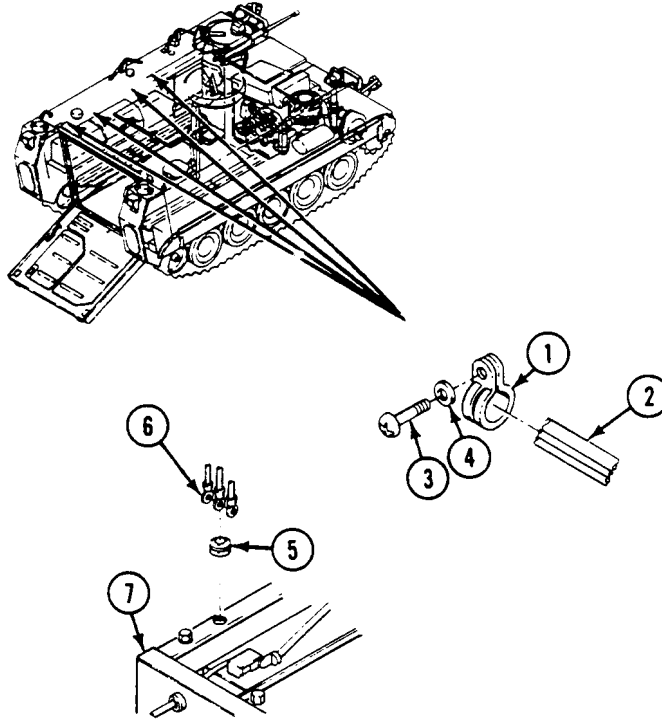

7. Install circuit 48 lead (8), M113A3 only circuit 48 lead (9), Circuit 772 lead (10), circuit 778 lead (11), and positive jumper lead (12) on positive terminal (13) of third battery (14). Secure with screw (15) and nut (16).

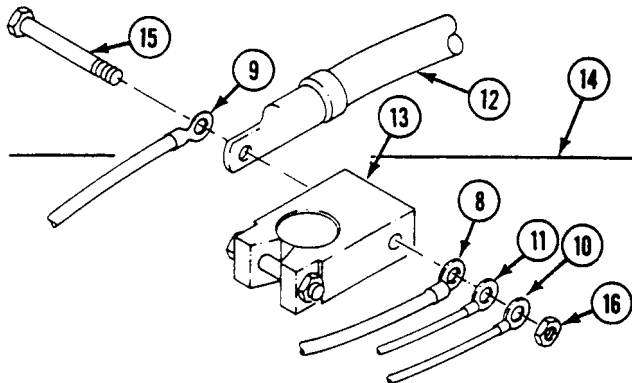

**REPLACE BATTERY-TO-RADIO WIRING HARNESS (LEFT SIDE) (M113A3 AND
M1059A3 ONLY) — Continued**

0369 00 ■

FOLLOW-THROUGH STEPS

1. Install rear battery box cover (see your -10).
2. Connect battery ground strap (WP 0337 00).
3. Start engine (see your -10).
4. Raise and lock ramp (see your -10).
5. Stop engine (see your -10).

END OF TASK

REPLACE BATTERY-TO-RADIO WIRING HARNESS (RIGHT SIDE) (M113A3 ONLY)

0370 00

THIS WORK PACKAGE COVERS:

- Removal (page 0370 00-2).
- Inspection and Repair (page 0370 00-5).
- Installation (page 0370 00-6).

INITIAL SETUP:

Maintenance Level

Unit

Personnel Required

Unit Mechanic

Tools and Special Tools

General Mechanic's Tool Kit (WP 0926 00, Item 65)

References

See your -10

Materials/Parts

- Cord (WP 0928 00, Item 31)
- Grommet
- Locknut (8)
- Lockwasher
- Lockwasher (10)
- Strap (3)

Equipment Condition

- Engine stopped (see your -10)
 - Carrier blocked (see your -10)
 - Spall liners opened (see your -10)
 - Battery ground strap disconnected (WP 0337 00)
 - Second battery box cover removed (see your -10)
-

REPLACE BATTERY-TO-RADIO WIRING HARNESS (RIGHT SIDE) (M113A3 ONLY) —
Continued

0370 00

REMOVAL**NOTE**

There are two circuit 48 leads connected to positive terminal of third battery. Replace circuit 48 lead which runs along hull past battery boxes and capacitor, to opposite side of carrier.

1. Remove nut (1) and screw (2) securing positive jumper lead (3), circuit 772 lead (4), circuit 778 lead (5), and two circuit 48 leads (6)(7) to positive terminal (8) of third battery (9).

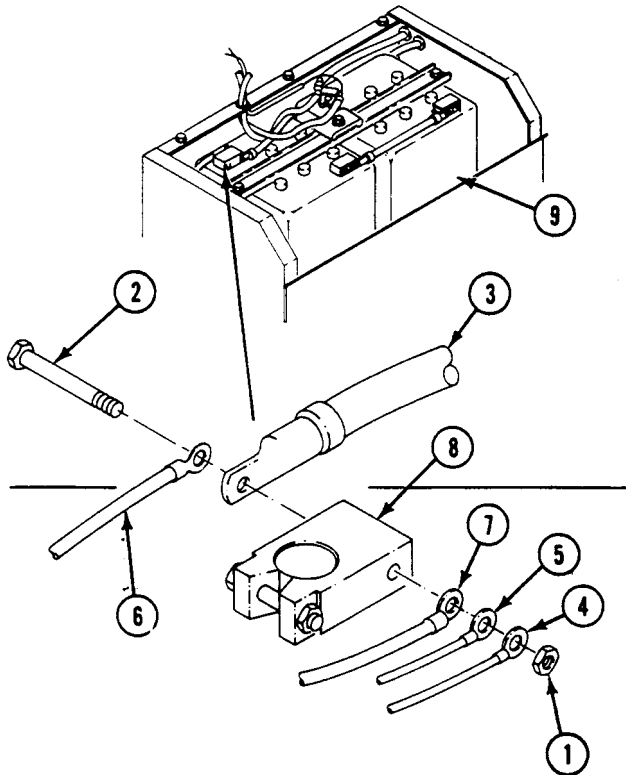

REPLACE BATTERY-TO-RADIO WIRING HARNESS (RIGHT SIDE) (M113A3 ONLY) —
Continued

0370 00

2. Remove circuit 48 lead (1) and grommet (2) from battery box (3). Discard grommet.
3. Remove ten screws (4), lockwashers (5), clamps (6), and harness (7) from hull weldnuts. Discard lockwashers.

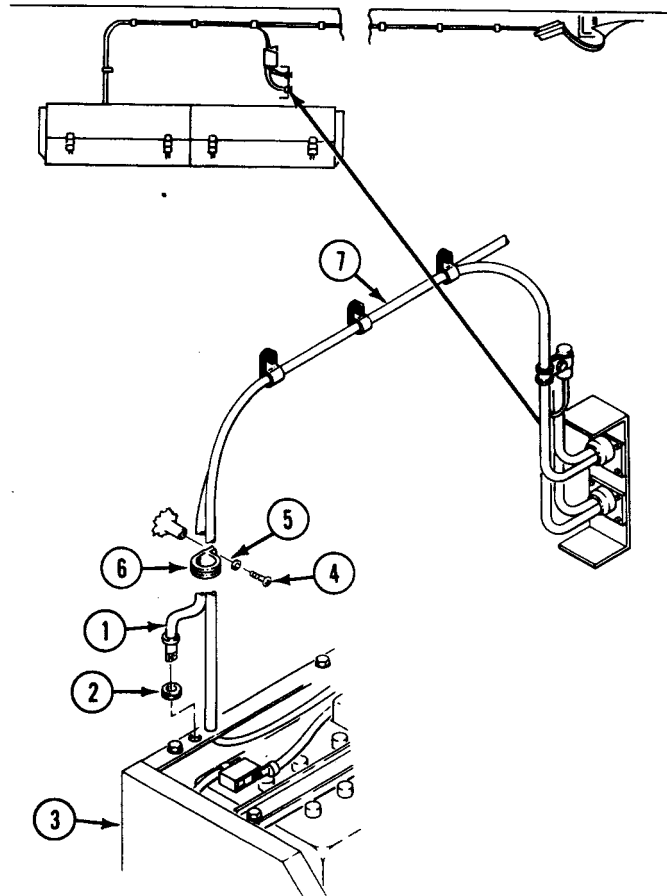

**REPLACE BATTERY-TO-RADIO WIRING HARNESS (RIGHT SIDE) (M113A3 ONLY) —
Continued**

0370 00

4. Tie cord to harness (7) with strong knot. Pull harness through hull beam (8) from opposite side of carrier. Untie cord from harness, leaving cord hanging from both ends of hull beam.
5. Remove three straps (9), eight screws (10), washers (11), clamps (12), and harness (7) from hull weldnuts. Discard straps.

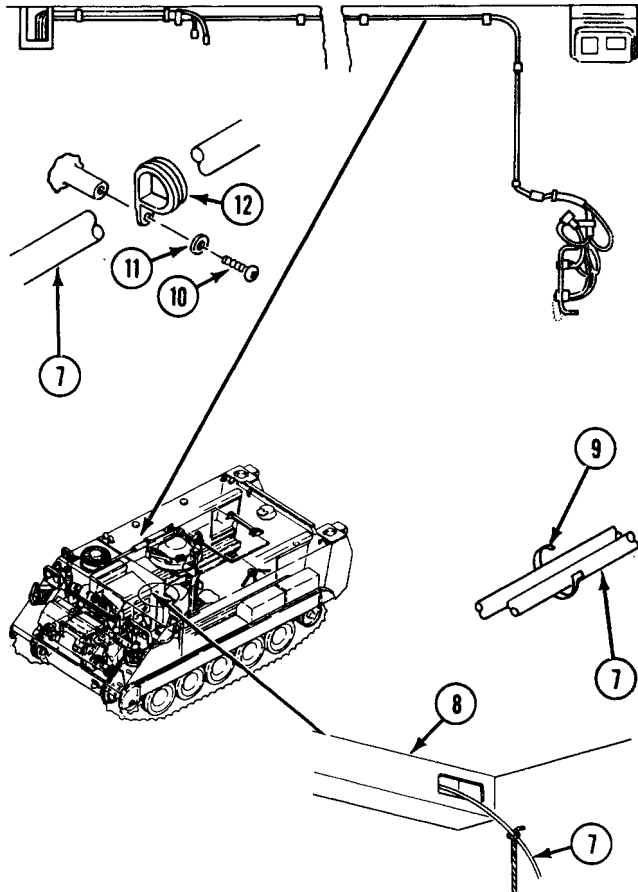

REPLACE BATTERY-TO-RADIO WIRING HARNESS (RIGHT SIDE) (M113A3 ONLY) —
Continued

0370 00

6. Remove screw (6), washer (5), two ground leads (4)(3), capacitor (2), and clamp (1) from hull weldnut.
7. Remove screw (13), lockwasher (14), and circuit 48 lead (15) from capacitor (2). Discard lockwasher.
8. Remove cap (11) from receptacle (8).
9. Remove eight screws (12), locknuts (7), two receptacles (8), and cap chain (10) from bracket (9). Discard locknuts.

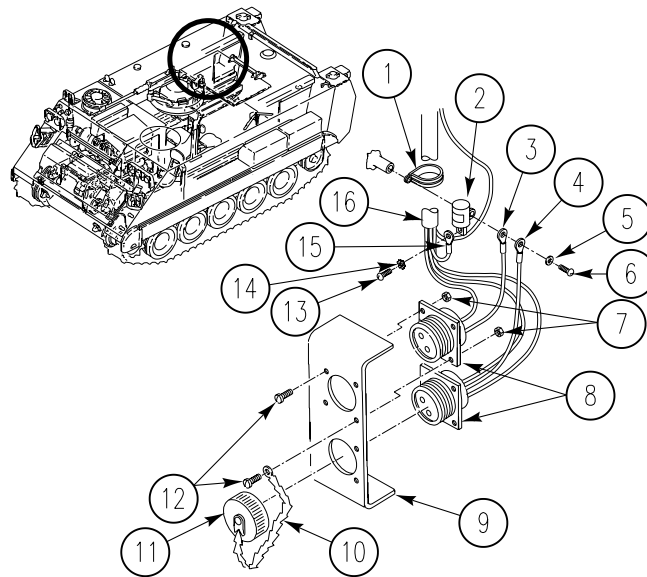
**INSPECTION-ACCEPTANCE AND REJECTION CRITERIA****INSPECTION AND REPAIR**

1. Check for damaged connectors and terminals. Repair as needed (WP 0382 00).

REPLACE BATTERY-TO-RADIO WIRING HARNESS (RIGHT SIDE) (M113A3 ONLY) —
Continued

0370 00

INSTALLATION

1. Install two receptacles (11) and cap chain (14) on bracket (15). Secure with eight screws (12) and new locknuts (13).
2. Install cap (10) on receptacle (11).

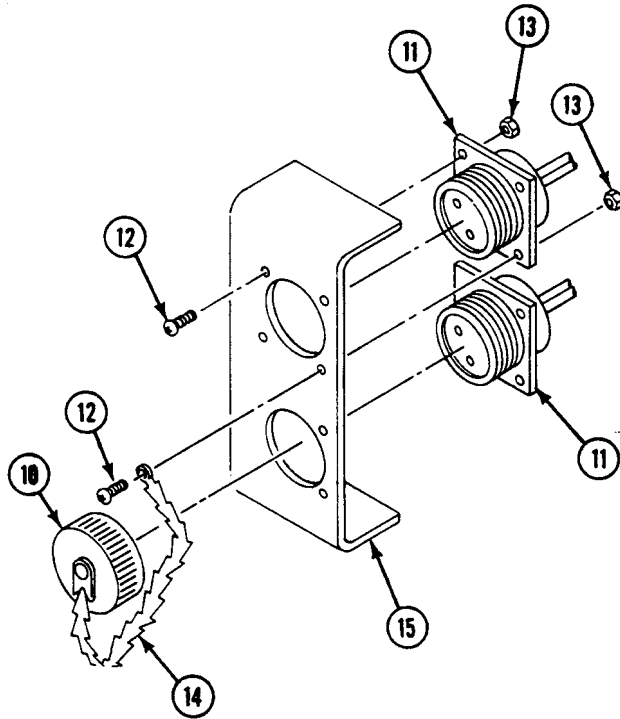

REPLACE BATTERY-TO-RADIO WIRING HARNESS (RIGHT SIDE) (M113A3 ONLY) —
Continued

0370 00

3. Install clamp (1), capacitor (2), and two ground leads (3)(4) on hull. Secure with screw (5) and washer (6).
4. Install circuit 48 lead (7) on capacitor (2). Secure with screw (8) and new lockwasher (9).

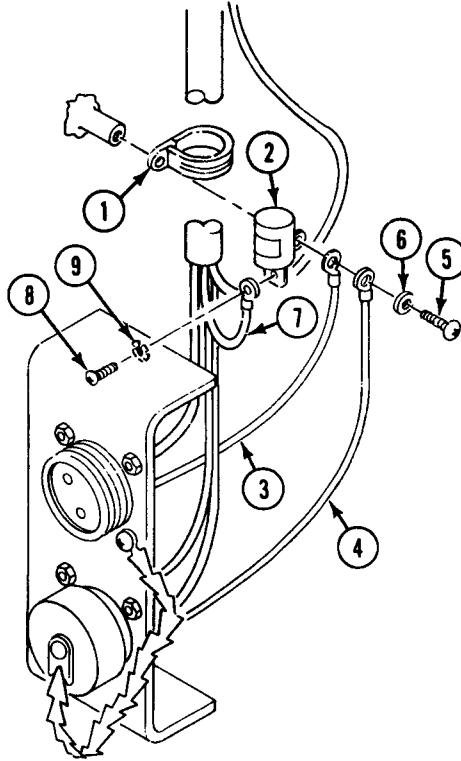

REPLACE BATTERY-TO-RADIO WIRING HARNESS (RIGHT SIDE) (M113A3 ONLY) —
Continued

0370 00

5. Secure circuit 6B positive (13) to harness (10) with new strap (14). Install two new straps (15) and eight clamps (16) on harness. Secure with eight washers (17) and screws (18).
6. Tie cord hanging from beam to new or repaired harness (10) with strong knot. Pull cord from opposite side of carrier, routing harness through hull beam. Untie cord from harness.

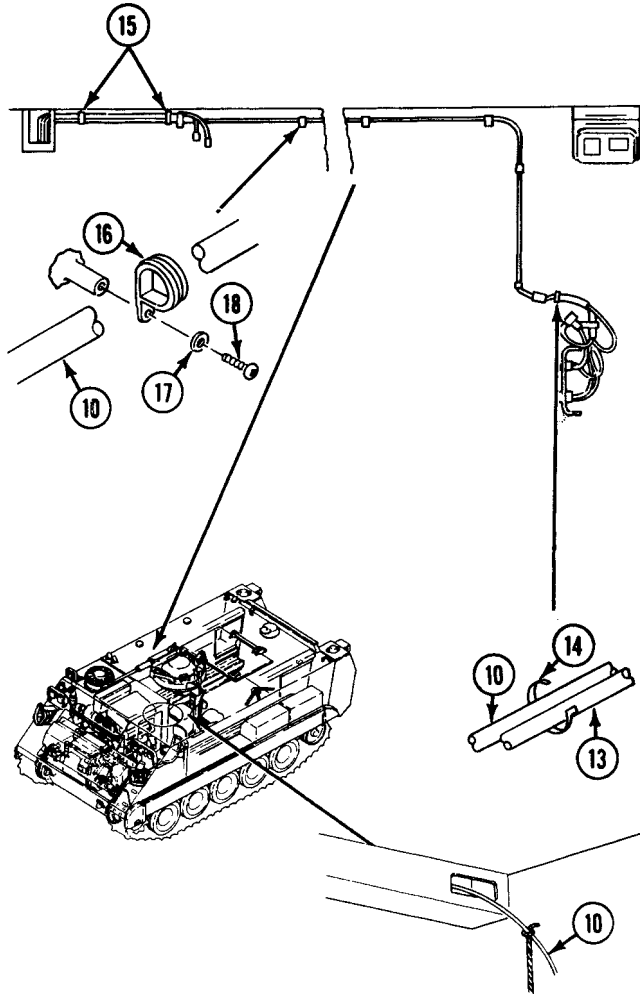

REPLACE BATTERY-TO-RADIO WIRING HARNESS (RIGHT SIDE) (M113A3 ONLY) —
Continued

0370 00

7. Install ten clamps (1) on harness (2). Secure clamps to hull with ten screws (3) and new lockwashers (4).
8. Install new grommet (5) on circuit 48 lead (6) Route lead through hole in battery box (7). Secure grommet in box.

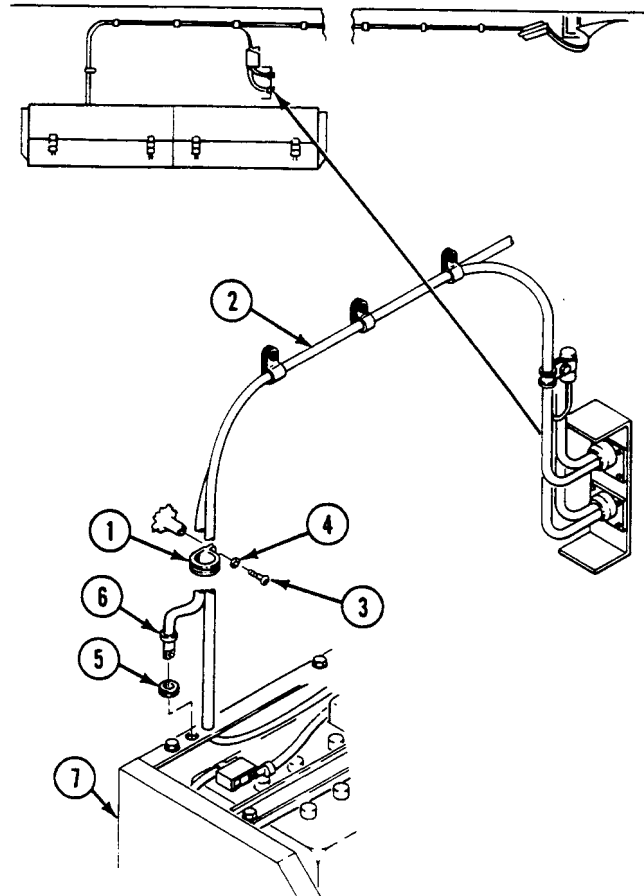

REPLACE BATTERY-TO-RADIO WIRING HARNESS (RIGHT SIDE) (M113A3 ONLY) —
Continued

0370 00

9. Install two circuit 48 leads (6)(8), Circuit 772 lead (9), circuit 778 lead (10), and positive jumper lead (11) on positive terminal (12) of third battery (13). Secure with screw (14) and nut (15).

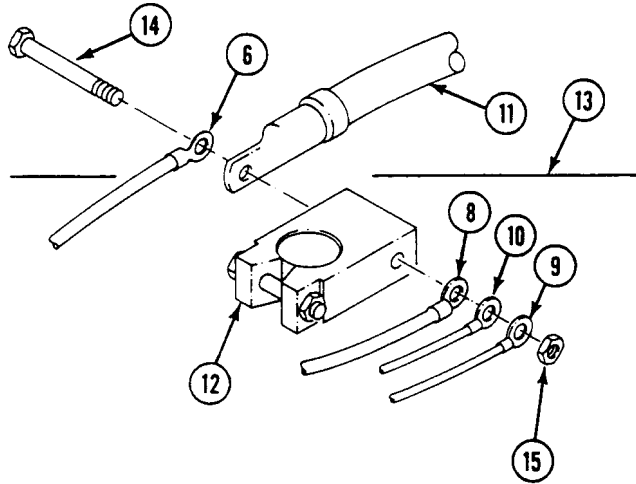

FOLLOW-THROUGH STEPS

1. Install second battery box cover (see your -10).
2. Connect battery ground strap (WP 0337 00).

END OF TASK

REPLACE RIGHT HEADLIGHT WIRING HARNESS

0373 00

THIS WORK PACKAGE COVERS:

- Removal (page 0373 00-1).
- Inspection and Repair (page 0373 00-3).
- Installation (page 0373 00-3).

INITIAL SETUP:

Maintenance Level

Unit

References

See your -10

Tools and Special Tools

- General Mechanic's Tool Kit (WP 0926 00, Item 65)
- Multimeter (WP 0926 00, Item 30)

Equipment Condition

- Engine stopped (see your -10)
- Carrier blocked (see your -10)
- Trim vane lowered (see your -10)
- Power plant access door opened (see your -10)
- Power plant grill raised (WP 0464 00)
- Battery ground strap disconnected (WP 0337 00), (WP 0338 00), or (WP 0339 00)

Materials/Parts

- Insulating tape (WP 0928 00, Item 39)
- Lockwasher (2)
- Lockwasher (4)
- Terminal (6)

Personnel Required

Unit Mechanic

REMOVAL

1. Disconnect right headlight wiring harness (1) from front main wiring harness (2) at driver's compartment bulkhead.
2. Disconnect circuits 514 and 515 leads (3) and (4) from right infrared headlight (5).
3. Disconnect circuit 25 lead (6) from horn (7).
4. Disconnect circuit 20 lead (8) from right blackout marker light (9).
5. Disconnect circuits 17 and 18 leads (10) and (11) from right service headlight (12).

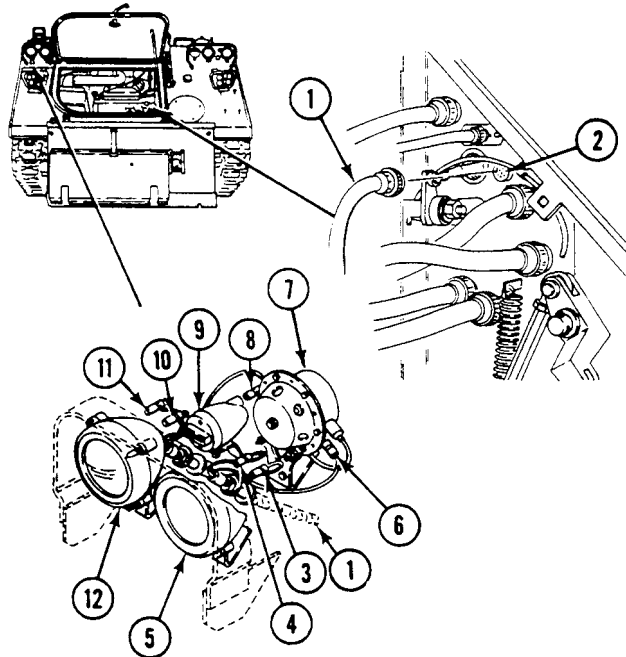

REPLACE RIGHT HEADLIGHT WIRING HARNESS — Continued

0373 00

6. Remove six terminals (1), insulators (2), and connectors (3) from six leads disconnected in Steps 1 - 5. Discard terminals.
7. Remove tape from circuit 17 and 18 leads (4) and (5) and remove six leads for circuits 17, 18, 20, 25, 514, 515 from hull bushings (10).
8. Remove four nuts (6), lockwashers (7), washers (8), and two washers (9) from two bushings (10). Unscrew and remove bushings from hull. Discard lockwashers.

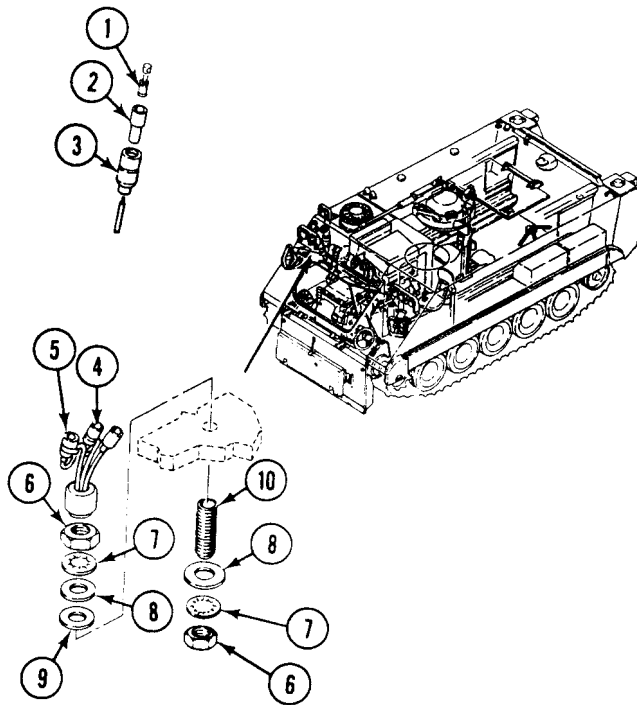

9. Remove two screws (11), lockwashers (18), four clamps (13), and harness (12) from two weldnuts (19).

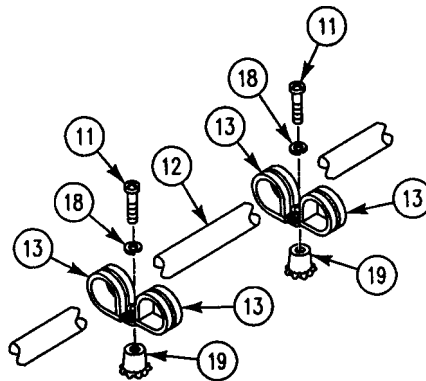

10. Remove screw (14), clamp (15), and harness (12) from weldnut (16).

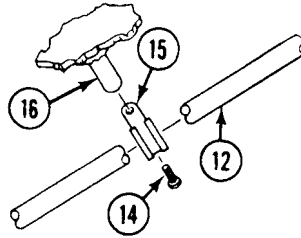

INSPECTION-ACCEPTANCE AND REJECTION CRITERIA

INSPECTION AND REPAIR

1. Check leads for continuity. Replace bad leads.
2. Check harness for damage. Repair damaged connectors or terminals (WP 0382 00).

INSTALLATION

NOTE

New harness assembly comes with hull bushing assemblies installed.

1. Connect right headlight wiring harness (12) to front main wiring harness (17) at driver's compartment bulkhead.

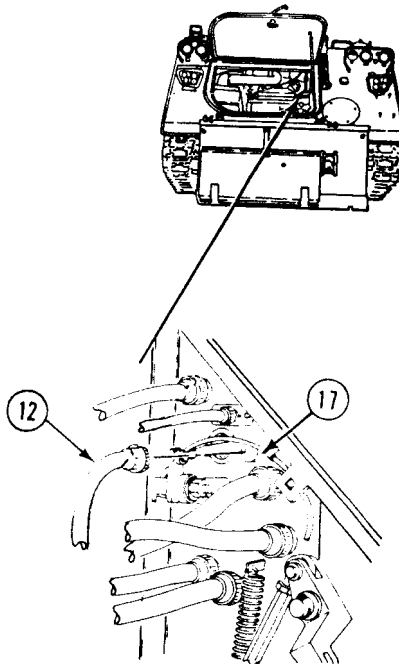

2. Install clamp (14) on harness (12). Secure clamp to hull weldnut (16) with screw (14).

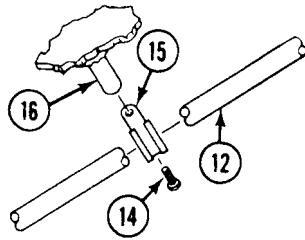

3. Install four clamps (13) on harnesses (12). Secure clamps to hull weldnuts (19) with two screws (11) and new lockwashers (18).

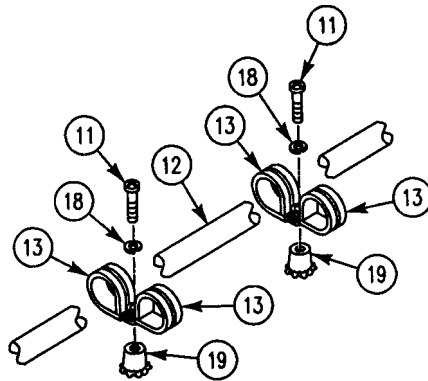

REPLACE RIGHT HEADLIGHT WIRING HARNESS — Continued

0373 00

4. Thread two bushings (1) into hull. Secure with four nuts (2), new lockwashers (3), washers (4), and two washers (5). Do not tighten nuts.
5. Locate service headlight and blackout marker light bushing hole in hull. Slowly slide leads for circuit 17, 18, 20 (6) through hole. Do not damage wiring leads.
6. Locate second bushing hole in hull. Slowly slide leads for circuits 25, 514, 515 (6) through hole. Do not damage wiring leads.
7. Install six new terminals (7), insulators (8), and connectors (9) on six leads.

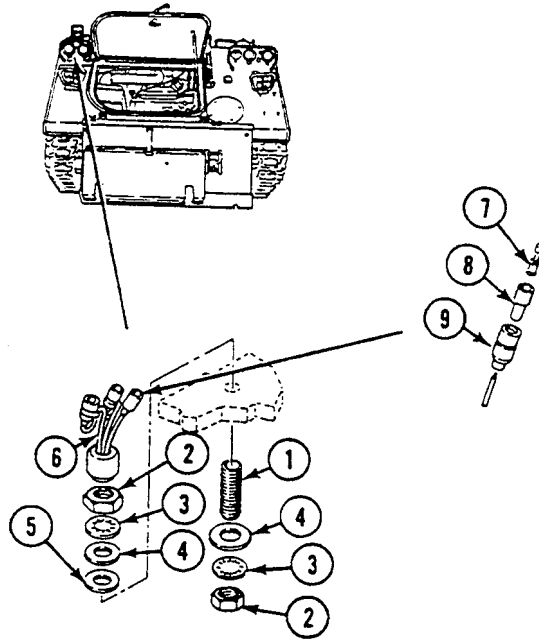

REPLACE RIGHT HEADLIGHT WIRING HARNESS — Continued

0373 00

8. Connect leads 514 (10) and 515 (11) to infrared headlamps (12).
9. Connect lead 25 (13) to horn (14).
10. Connect lead 20 (15) to marker lamp (16).
11. Bend and tape leads 17 and 18 (17) and (18) as shown. Connect leads to service headlamps (19).

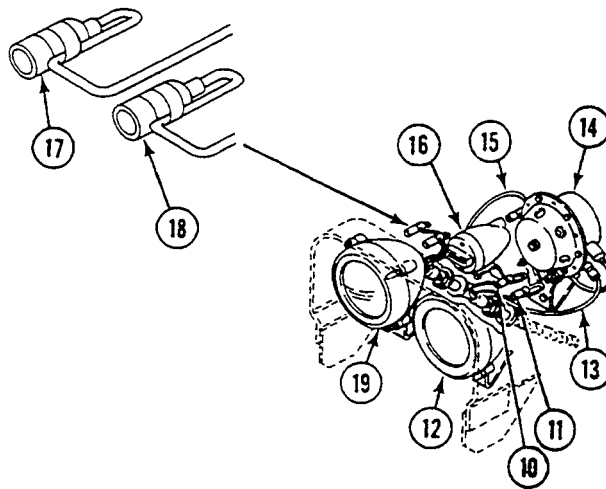
**FOLLOW-THROUGH STEPS**

1. Lower power plant grill (WP 0464 00).
2. Connect battery ground strap (WP 0337 00), (WP 0338 00), or (WP 0339 00).
3. Close power plant access door (see your -10).
4. Raise trim vane (see your -10).

END OF TASK

REPLACE WARNING PANEL WIRING HARNESS

0374 00

THIS WORK PACKAGE COVERS:

- Removal (page 0374 00-1).
- Inspection and Repair (page 0374 00-3).
- Installation (page 0374 00-4).

INITIAL SETUP:

Maintenance Level

Unit

References

See your -10

Tools and Special Tools

General Mechanic's Tool Kit (WP 0926 00, Item 65)

Materials/Parts

- Lockwasher
- Lockwasher
- Lockwasher (4)

Equipment Condition

- Engine stopped (see your -10)
- Carrier blocked (see your -10)
- Battery ground strap disconnected (WP 0337 00), (WP 0338 00), or (WP 0339 00)

Personnel Required

Unit Mechanic

REMOVAL

1. Disconnect wiring harness lead (1) from STEERING LOCKED indicator (2) on warning light panel (3).
2. Disconnect wiring harness connector (4) from connector (5).

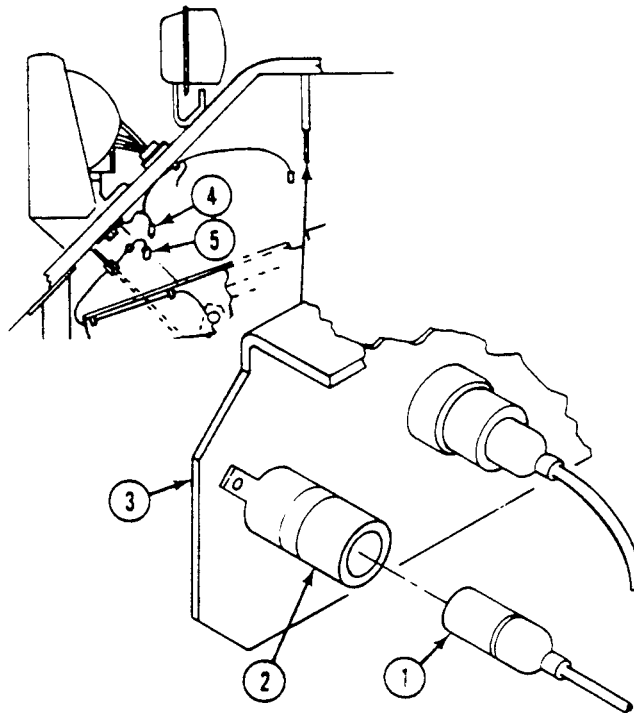

REPLACE WARNING PANEL WIRING HARNESS — Continued**0374 00**

3. Remove screw (6), lockwasher (7), and ground lead (8) from plate (9). Discard lockwasher.
4. Remove screw (10), lockwasher (11), and clamp (12) from upper nose plate of front hull. Discard lockwasher.

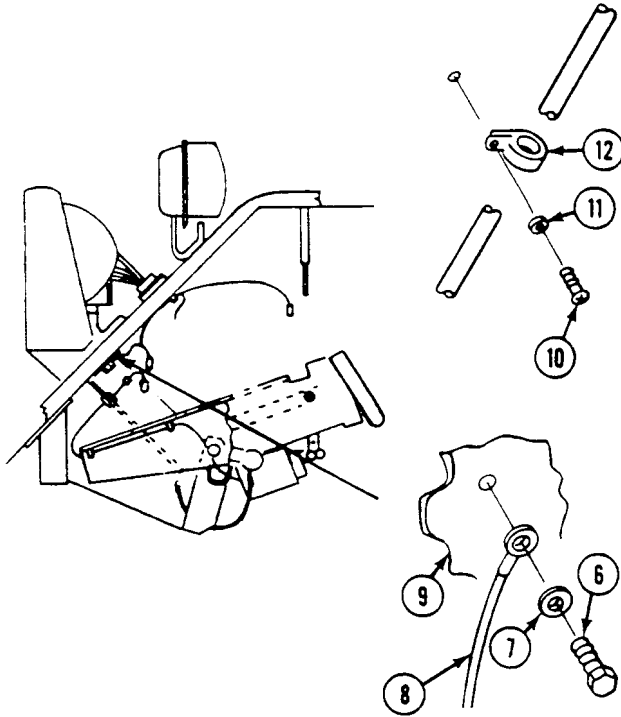

REPLACE WARNING PANEL WIRING HARNESS — Continued

0374 00

5. Remove four screws (1), lockwashers (2), clamps (4), and wiring harness (3) from weldnuts (5). Discard lockwashers.
6. Disconnect wiring harness (3) from connector (5).

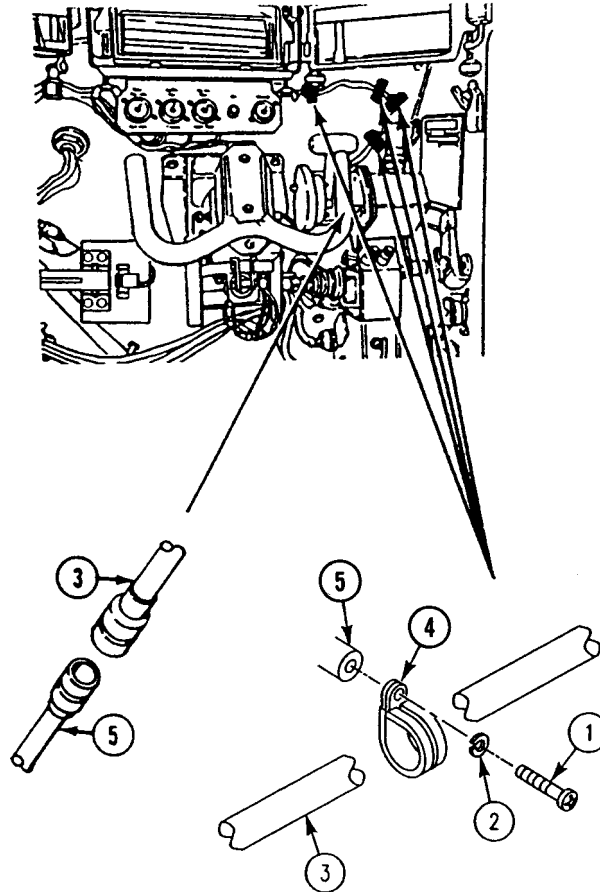
**INSPECTION-ACCEPTANCE AND REJECTION CRITERIA****INSPECTION AND REPAIR**

1. Check connectors. Repair as needed (WP 0382 00).

INSTALLATION

1. Connect wiring harness (3) to connector (5).
2. Install wiring harness (3) and clamps (4) on four weldnuts. Secure with four new lockwashers (2) and screws (1).

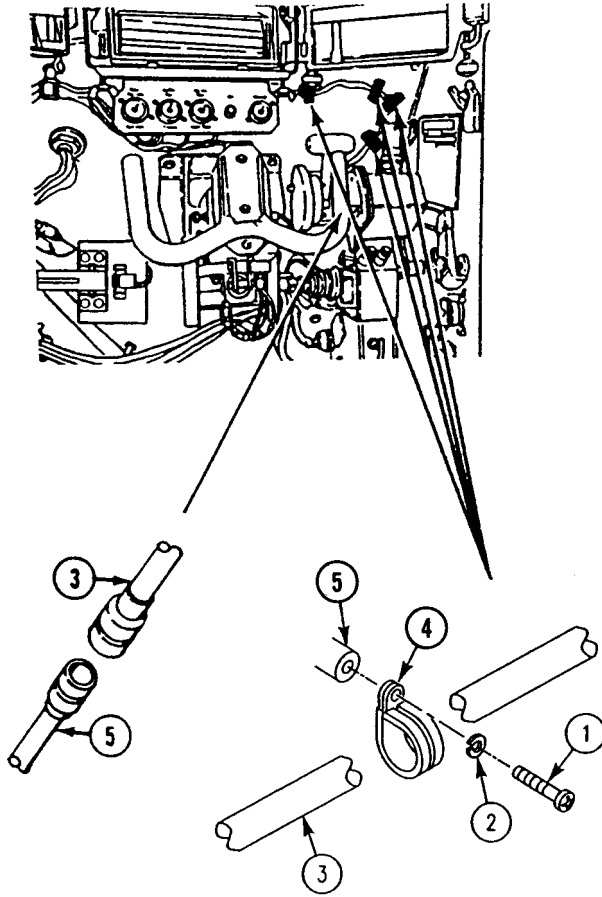

REPLACE WARNING PANEL WIRING HARNESS — Continued

0374 00

3. Install wiring harness (6) and clamp (7) on upper nose plate of front hull. Secure with screw (8), new lockwasher (9) and clamp (7).
4. Install ground lead (10) on plate (11). Secure with screw (12) and new lockwasher (13).

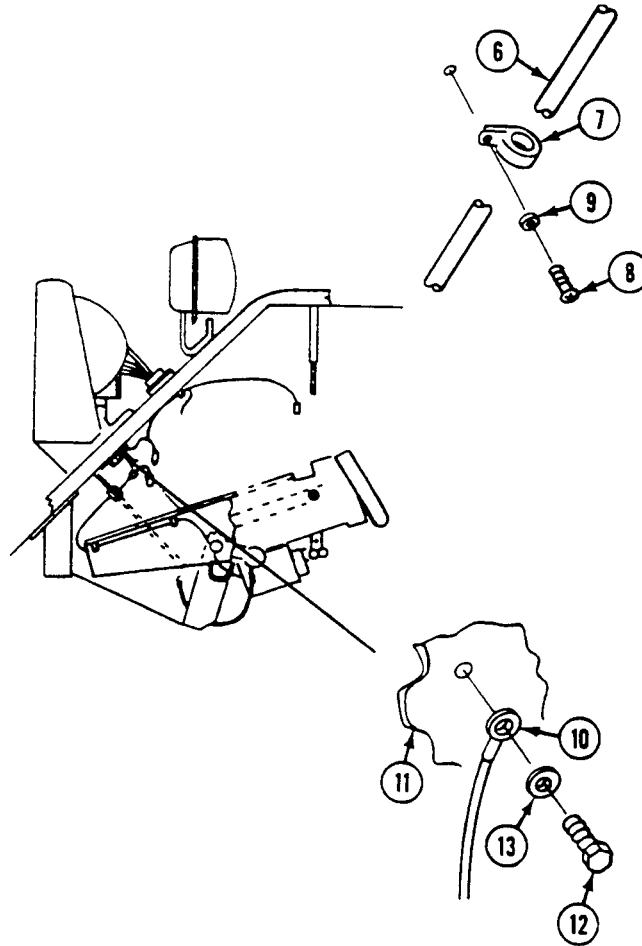

REPLACE WARNING PANEL WIRING HARNESS — Continued

0374 00

5. Connect wiring harness connector (1) to connector (2).
6. Connect wiring harness lead (3) to STEERING LOCKED indicator (4) on warning light panel (5).

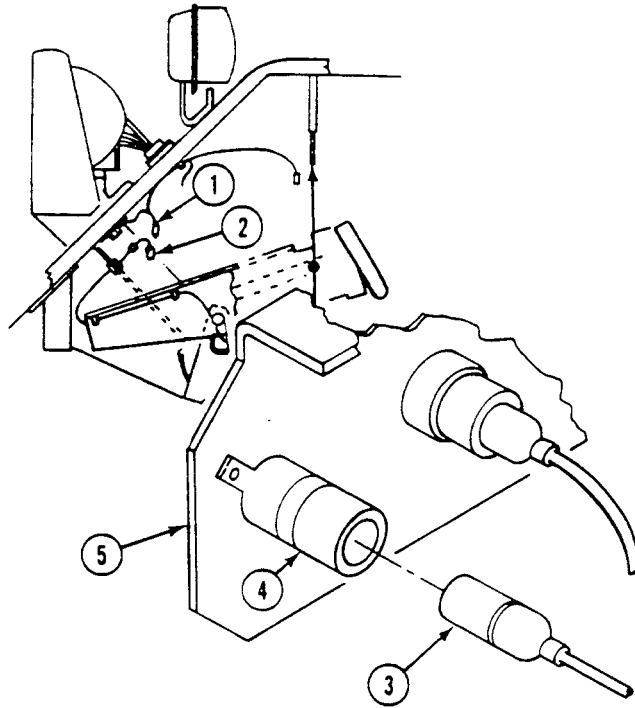
**FOLLOW-THROUGH STEPS**

1. Connect battery ground strap (WP 0337 00), (WP 0338 00), or (WP 0339 00).
2. Turn MASTER SWITCH to ON (see your -10).
3. Place transmission controller in SL position. Check that STEERING LOCKED indicator is on (see your -10).
4. Turn MASTER SWITCH to OFF (see your -10).

END OF TASK

REPLACE TRAILER HARNESS

0375 00

THIS WORK PACKAGE COVERS:

- Removal (page 0375 00-1).
- Inspection (page 0375 00-2).
- Installation (page 0375 00-3).

INITIAL SETUP:

Maintenance Level

Unit

References

See your -10

Tools and Special Tools

- General Mechanic's Tool Kit (WP 0926 00, Item 65)
- Multimeter (WP 0926 00, Item 30)

Equipment Condition

- Engine stopped (see your -10)
- Carrier blocked (see your -10)
- Ramp raised (see your -10)
- Rear floor plates removed (WP 0539 00), (WP 0540 00), (WP 0541 00), (WP 0542 00), (WP 0543 00), (WP 0544 00), or (WP 0545 00)
- Battery ground strap disconnected (WP 0337 00), (WP 0338 00), or (WP 0339 00)

Materials/Parts

- Gasket
- Lockwasher (2)

Personnel Required

Unit Mechanic

REMOVAL

1. Disconnect rear wiring harness circuit 21, 22, 23, and 24 leads (1) from trailer wiring harness circuit 21, 22, 23, and 24 leads (2).

2. Remove shell connectors from leads (2) (WP 0382 00).
3. Remove screw (3), clamp (4), lockwasher (5), circuit 90 lead (6), lockwasher (7) from hull weldnut. Discard lockwashers.
4. Remove four screws (8) and receptacle cover (9) from ramp. Carefully remove receptacle (10) with attached leads (2) and gasket (11) from ramp. Discard gasket.
5. If needed, remove connector (12) from rear bulkhead.
6. If needed, remove spring (13) and elbow (14) from ramp.

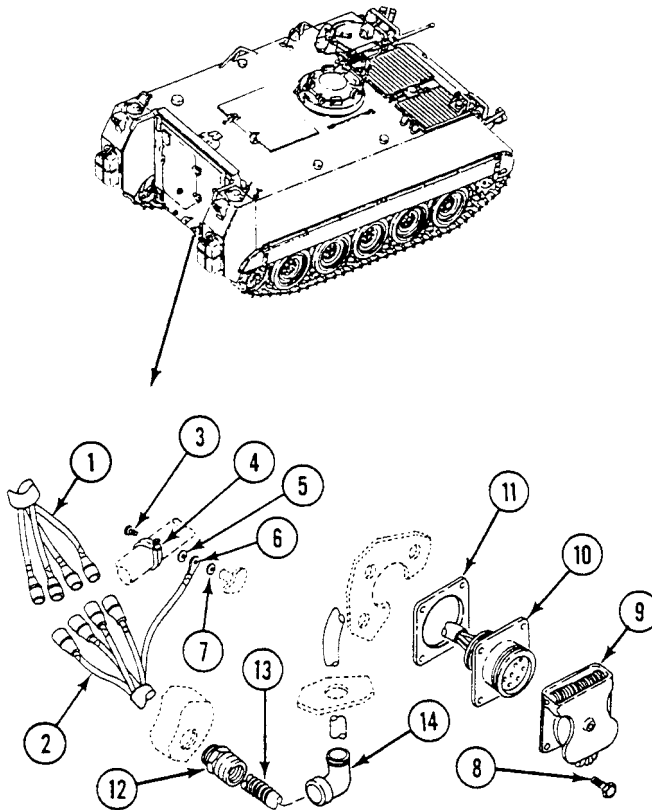

INSPECTION-ACCEPTANCE AND REJECTION CRITERIA

1. Check receptacle. If receptacle is cracked or broken, notify supervisor.

INSTALLATION

1. If removed, install spring (1) and elbow (2) in ramp.
2. If removed, install connector (3) in rear bulkhead.
3. Route leads (4) through new gasket (5), and out through elbow (2).
4. Install gasket (5), receptacle (6), and cover (7) on ramp. Secure with four screws (8).
5. Route leads (4) through spring (1) and connector (3).
6. Install circuit 90 lead (9) between clamp (10) and weldnut on hull. Secure with new lockwasher (11), new lockwasher (12), and screw (13).
7. Install shell connectors on leads (4) (WP 0382 00).
8. Connect leads (4) to leads (14).

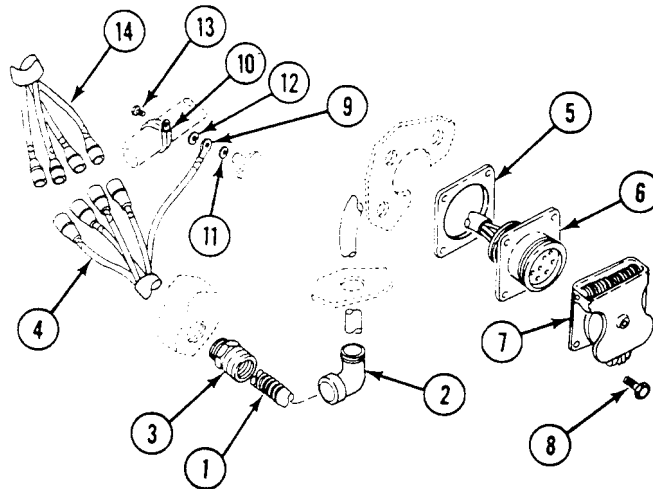
**FOLLOW-THROUGH STEPS**

1. Install rear floor plates (WP 0539 00), (WP 0540 00), (WP 0541 00), (WP 0542 00), (WP 0543 00), (WP 0544 00), or (WP 0545 00).
2. Connect battery ground strap (WP 0337 00), (WP 0338 00), or (WP 0339 00).
3. Turn MASTER SWITCH ON (see your -10).
4. Check with multimeter to make sure harness is installed properly.
5. Turn MASTER SWITCH OFF (see your -10).

END OF TASK

REPLACE RADIAC WIRE HARNESS (M113A3, M577A3, AND M1068A3 ONLY)

0376 00

THIS WORK PACKAGE COVERS:

Removal (page 0376 00-1).
Installation (page 0376 00-2).

INITIAL SETUP:

Maintenance Level

Unit

References

See your -10

Tools and Special Tools

General Mechanic's Tool Kit (WP 0926 00, Item 65)

Equipment Condition

Engine Stopped (see your -10)

Carrier blocked (see your -10)

Ramp lowered (see your -10)

Battery ground strap disconnected (WP 0337 00) or (WP 0338 00)

Materials/Parts

Cord (WP 0928 00, Item 31)

Personnel Required

Unit Mechanic

REMOVAL

1. Remove four clips (1) and RADIAC harness (2) from four cradles (3).
2. Remove electrical connectors (4) from end of harness (2) (WP 0382 00).
3. Tie 12-foot (3.7 m) cord to harness (2).
4. Pull harness (2) and cord through cross beam (5). Untie cord from harness (2), leaving cord in cross beam.

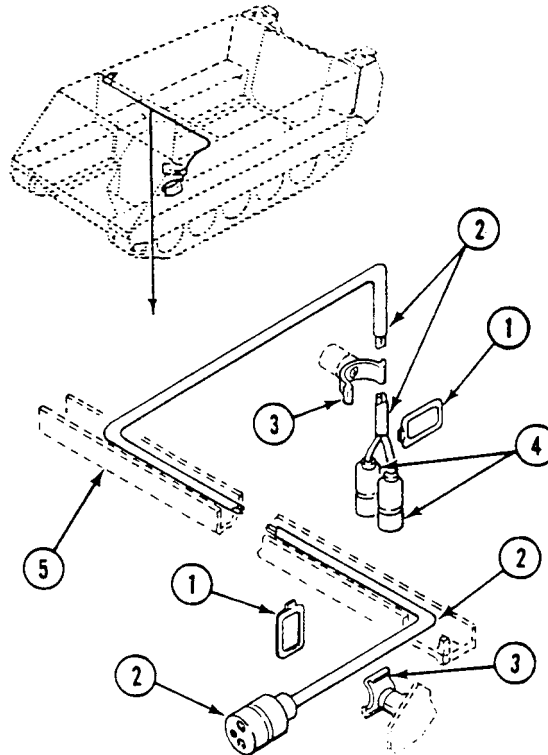

REPLACE RADIAC WIRE HARNESS (M113A3, M577A3, AND M1068A3 ONLY) —
Continued

0376 00

INSTALLATION

1. Tie cord left in cross beam (5) to end of RADIAC harness (2).
2. Pull cord and harness (2) through cross beam. Remove cord.
3. Install electrical connectors (4) on harness (2) (WP 0382 00).
4. Place harness (2) on four cradles (3) and secure with four clips (1).

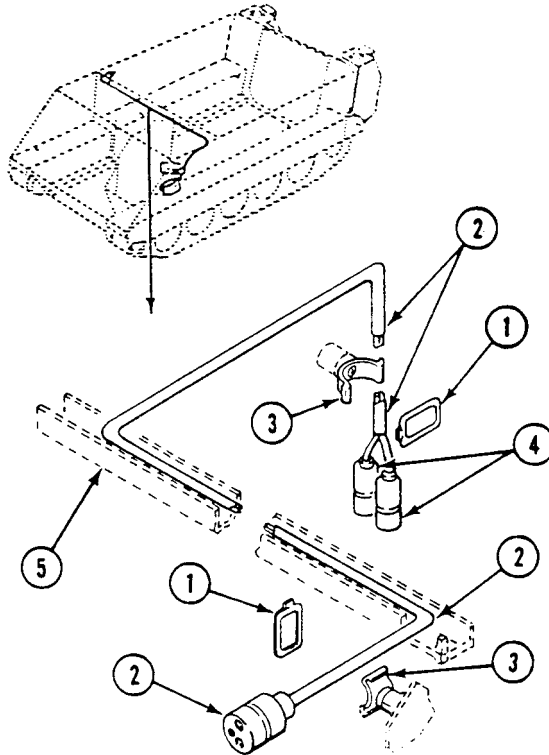
**FOLLOW-THROUGH STEPS**

1. Connect battery ground strap (WP 0337 00) or (WP 0338 00).
2. Start engine (see your -10).
3. Raise and lock ramp (see your -10).
4. Stop engine (see your -10).

END OF TASK

REPLACE UTILITY OUTLET LEAD ASSEMBLY (M577A3 AND M1068A3 ONLY)

0377 00

THIS WORK PACKAGE COVERS:

- Removal (page 0377 00-1).
- Inspection and Repair (page 0377 00-2).
- Installation (page 0377 00-2).

INITIAL SETUP:

Maintenance Level

Unit

References

See your -10

Tools and Special Tools

General Mechanic's Tool Kit (WP 0926 00, Item 65)

Equipment Condition

- Engine stopped (see your -10)
- Carrier blocked (see your -10)
- Battery ground lead disconnected (WP 0338 00)

Personnel Required

Unit Mechanic

REMOVAL

1. Disconnect lead assembly (1) from circuit 37 lead (2) at master switch panel (3).
2. Disconnect lead assembly (1) from circuit 38 lead (4) at instrument panel (5). Remove lead assembly.

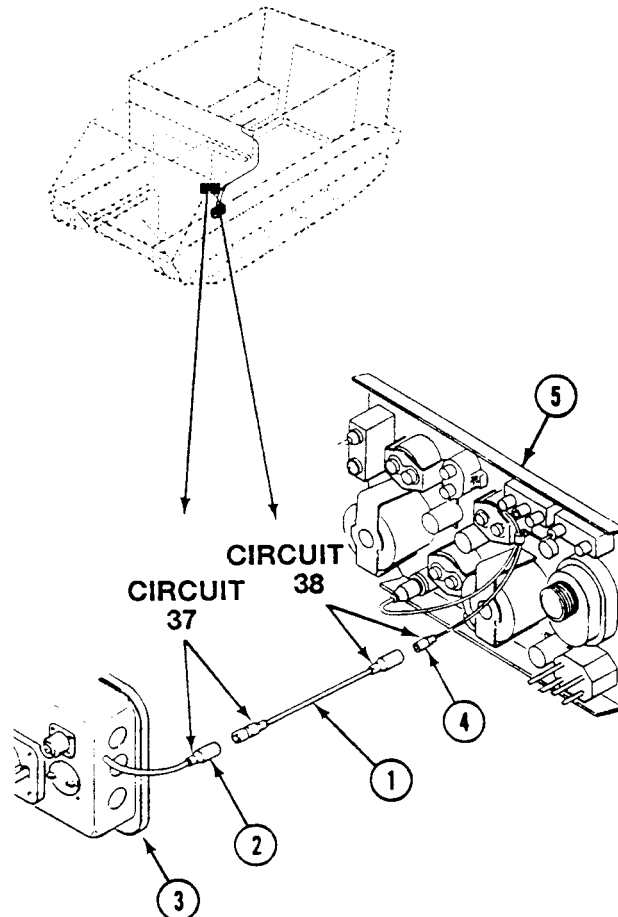

INSPECTION-ACCEPTANCE AND REJECTION CRITERIA

INSPECTION AND REPAIR

1. Check connectors. Repair as needed (WP 0382 00).

INSTALLATION

NOTE

Lead assembly is banded as circuit 37 at master switch panel and circuit 38 at instrument panel.
Make sure it is installed properly.

1. Connect lead assembly (1) to circuit 38 lead (4) at instrument panel (5).
2. Connect lead assembly (1) to circuit 37 lead (2) at master switch panel (3).

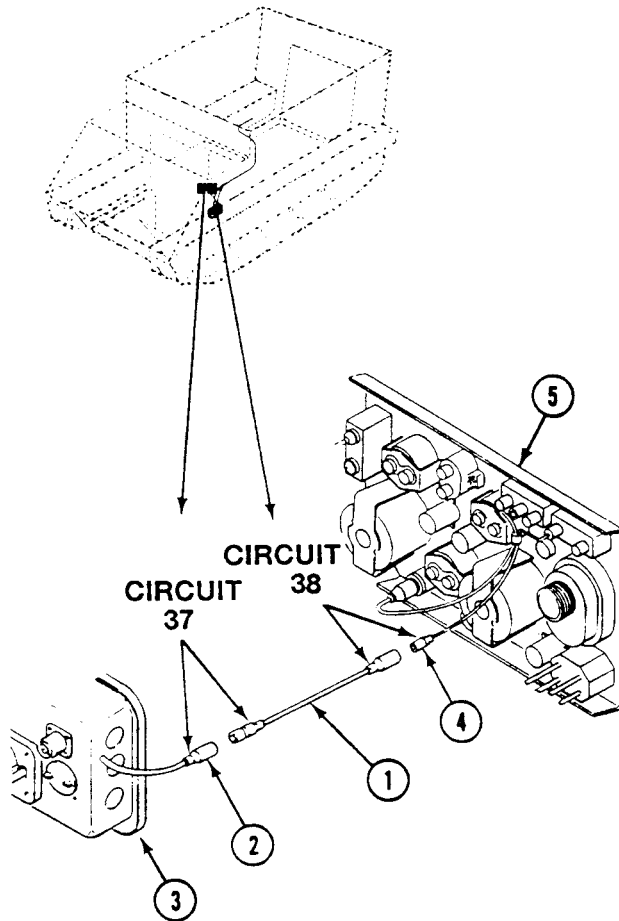

FOLLOW-THROUGH STEPS

1. Connect battery ground lead (WP 0338 00).
2. Turn MASTER SWITCH to ON to check that lead assembly is installed properly (see your -10).
3. Turn MASTER SWITCH to OFF (see your -10).

END OF TASK

REPLACE REAR UTILITY OUTLET RECEPTACLES (M577A3 AND M1068A3 ONLY)

0378 00

THIS WORK PACKAGE COVERS:

- Removal (page 0378 00-1).
 - Inspection and Repair (page 0378 00-2).
 - Installation (page 0378 00-2).
-

INITIAL SETUP:

Maintenance Level

Unit

References

See your -10

Tools and Special Tools

General Mechanic's Tool Kit (WP 0926 00, Item 65)

Equipment Condition

Engine stopped (see your -10)

Materials/Parts

Lockwasher (5)

Gasket

Carrier blocked (see your -10)

Personnel Required

Unit Mechanic

Ramp lowered (see your -10)

Battery ground lead disconnected (WP 0338 00)

REMOVAL

1. Remove two screws (1) retainer strip (2) and rubber shield (3) from hull mount (4).

REPLACE REAR UTILITY OUTLET RECEPTACLES (M577A3 AND M1068A3 ONLY) —
Continued

0378 00

2. Disconnect circuit 37A lead (5) (right receptacle) or circuit 37B lead (5) (left receptacle) from receptacle lead (6).
3. Remove clip (7) and rear main wiring harness (8) from cradle (9).
4. Remove screw (10), cradle (9), ground lead (11), and lockwasher (12) from hull weldnut. Discard lockwasher.
5. Remove four screws (13), lockwashers (14), chain (15), receptacle (16), and gasket (17) from rear bulkhead. Discard gasket and lockwashers.
6. Remove cap (18) from receptacle (16).

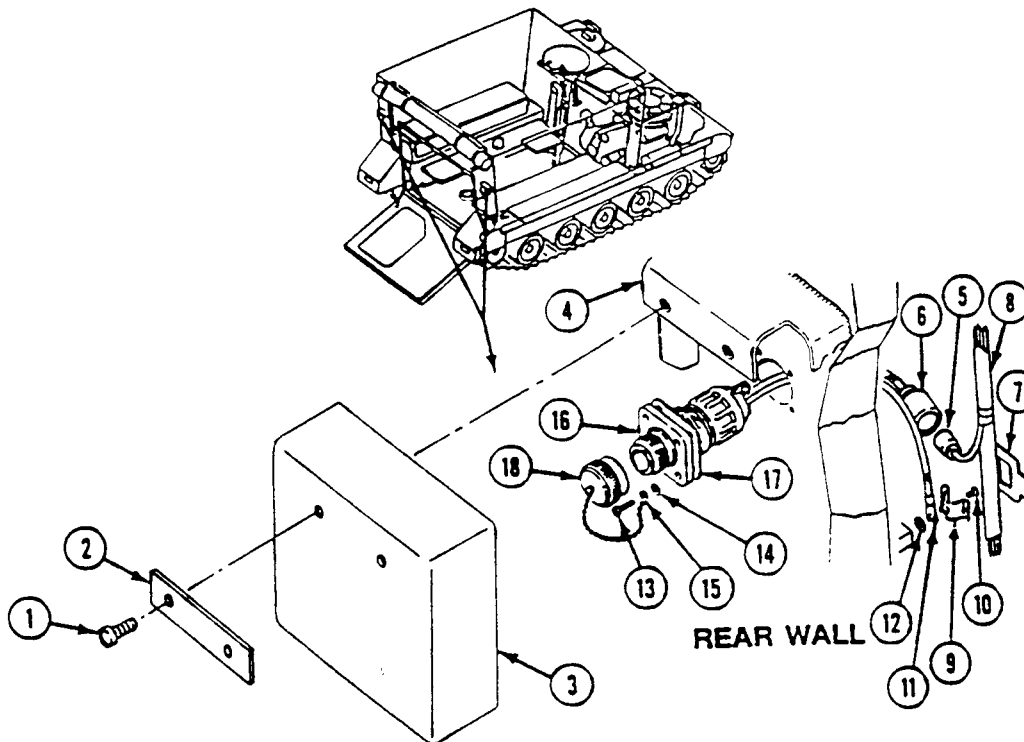
**INSPECTION-ACCEPTANCE AND REJECTION CRITERIA****INSPECTION AND REPAIR**

1. Check connectors. Repair as needed (WP 0382 00).

INSTALLATION

1. Install cap (1) on receptacle (2).
2. Place new gasket (3) and receptacle (2) on rear bulkhead. Secure with four new lockwashers (4) and screws (5) with chain (6) under head of one screw.
3. Install ground lead (7) and cradle (8) on hull weldnut. Secure with new lockwasher (9) and screw (10).
4. Place rear main wiring harness (11) in cradle (8). Secure with clip (12).
5. Connect receptacle lead (13) to circuit 37A lead (14) (right receptacle) or circuit 37B lead (14) (left receptacle).

**REPLACE REAR UTILITY OUTLET RECEPTACLES (M577A3 AND M1068A3 ONLY) —
Continued**

0378 00

6. Install rubber shield (15) on hull mount (16). Secure with retainer strip (17) and two screws (18).

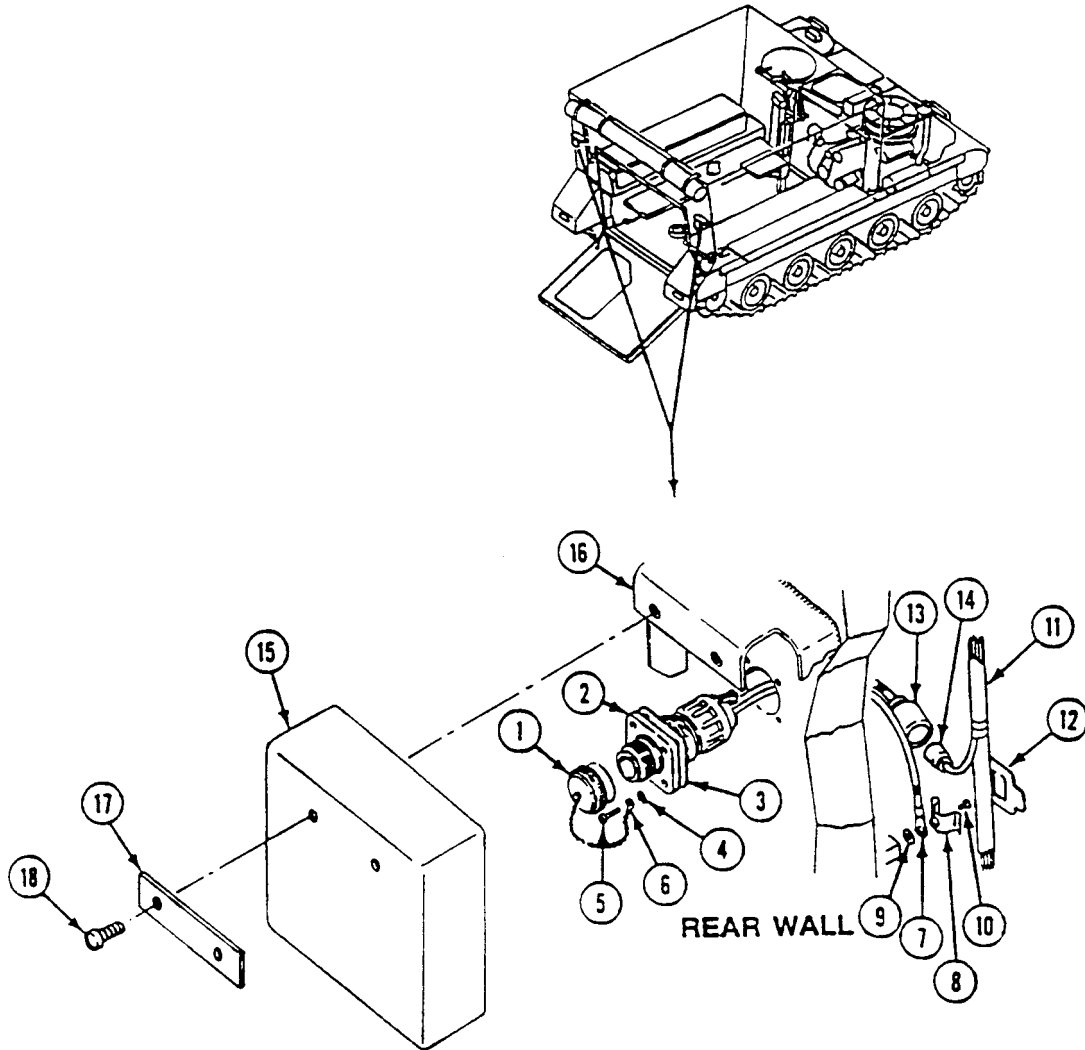

FOLLOW-THROUGH STEPS

1. Connect battery ground lead (WP 0338 00).
2. Turn MASTER SWITCH to ON to check that receptacle is installed properly (see your -10).
3. Start engine (see your -10).
4. Raise and lock ramp (see your -10).
5. Stop engine (see your -10).

END OF TASK

**REPLACE AUXILIARY POWER (SLAVE) RECEPTACLE GROUND LEAD
(M113A3, M1059A3, M1064A3, AND M58 ONLY)**

0379 00

THIS WORK PACKAGE COVERS:

Removal (page 0379 00-1).
Installation (page 0379 00-3).

INITIAL SETUP:

Maintenance Level

Unit

Personnel Required

Unit Mechanic

Tools and Special Tools

General Mechanic's Tool Kit (WP 0926 00, Item 65)

References

See your -10

Materials/Parts

Grommet
Locknut (8)
Locknut
Lockwasher

Equipment Condition

Engine stopped (see your -10)
Carrier blocked (see your -10)
Battery ground strap disconnected (WP 0337 00)

REMOVAL

1. Remove eight locknuts (1), washers (2), screws (3), and master switch panel (4) from distribution box (5). Discard locknuts.

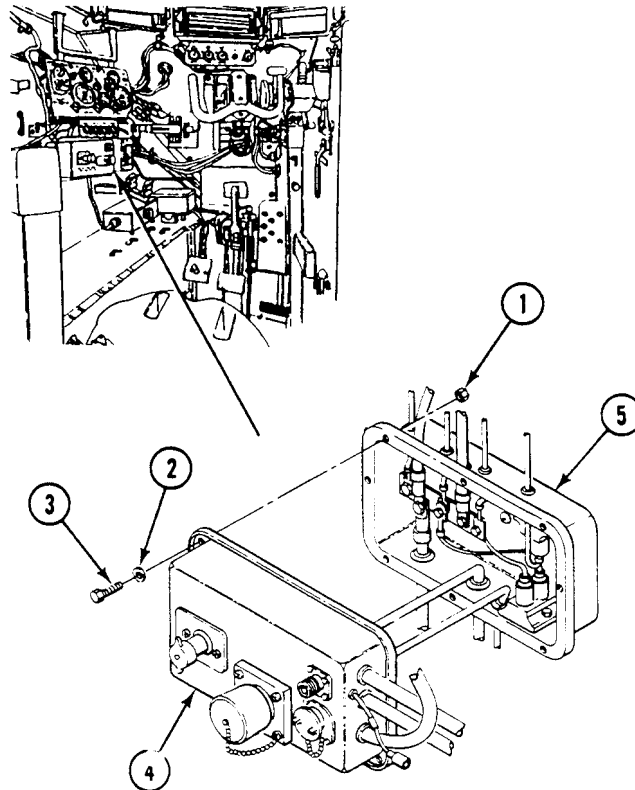

■ REPLACE AUXILIARY POWER (SLAVE) RECEPTACLE GROUND LEAD (M113A3, M1059A3, M1064A3, AND M58 ONLY) — Continued

0379 00

- Remove screw (6), lockwasher (7), and ground lead (8) from negative post (9) of auxiliary power receptacle (10). Do not discard lockwasher.

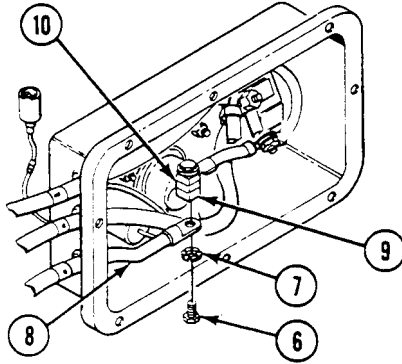

- Remove locknut (11), washer (12), lead (13), ground lead (8), and lockwasher (14) from instrument panel hull strut mount (15). Discard locknut and lockwasher.

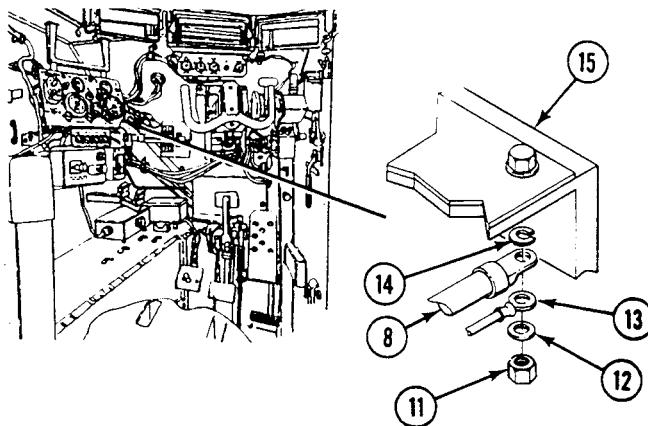

- Remove ground lead (1) and grommet (2) from master switch panel (3). Discard grommet.

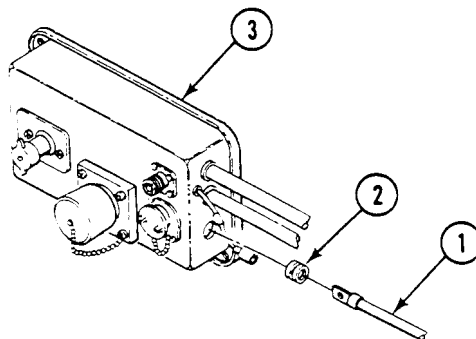

REPLACE AUXILIARY POWER (SLAVE) RECEPTACLE GROUND LEAD (M113A3, M1059A3, M1064A3, AND M58 ONLY) — Continued

0379 00 ■

INSTALLATION

1. Install new grommet (2) on ground lead (1). Route lead through master switch panel (3). Install grommet in panel.

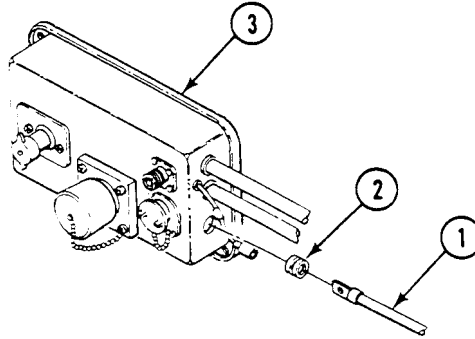

2. Install new lockwasher (4), ground lead (1), lead (5), washer (6), and new locknut (7). Tighten locknut.

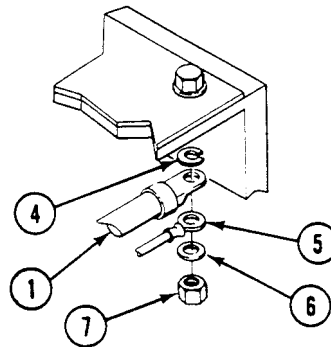

3. Install ground lead (1) on negative post (8) of auxiliary power receptacle (9). Secure with screw (10) and lockwasher (11).

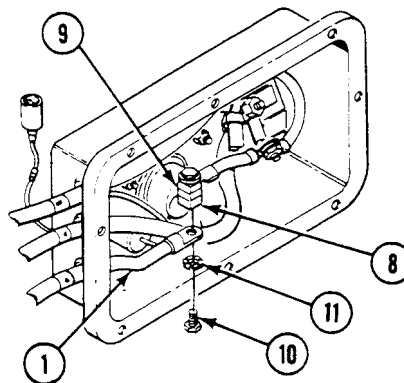

REPLACE AUXILIARY POWER (SLAVE) RECEPTACLE GROUND LEAD (M113A3, M1059A3, M1064A3, AND M58 ONLY) — Continued

0379 00

4. Install master switch panel (3) on distribution box (12). Secure with eight screws (13), washers (14), and new locknuts (15).

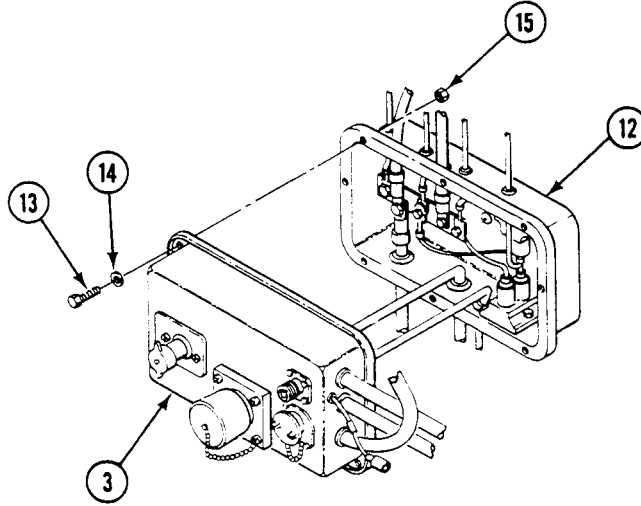
**FOLLOW-THROUGH STEPS**

1. Connect battery ground strap (WP 0337 00).

END OF TASK

**REPLACE MASTER SWITCH PANEL DOME LIGHTS LEAD ASSEMBLY
(M577A3 AND M1068A3 ONLY)**

0380 00

THIS WORK PACKAGE COVERS:

Removal (page 0380 00-1).
Installation (page 0380 00-3).

INITIAL SETUP:

Maintenance Level

Unit

Personnel Required

Unit Mechanic

Tools and Special Tools

General Mechanic's Tool Kit (WP 0926 00, Item 65)

References

See your -10

Materials/Parts

Gasket
Grommet
Locknut (8)

Equipment Condition

Engine stopped (see your -10)
Carrier blocked (see your -10)
Battery ground lead disconnected (WP 0338 00)

REMOVAL

1. Remove eight locknuts (1), washers (2), screws (3), and master switch panel (4) from distribution box (5). Discard locknuts.
2. Disconnect lead assembly (6) from front dome light switch (7), circuit breaker (8), and circuit 38E lead (9).
3. Pull lead assembly (6) with grommet (10) from master switch panel (4). Discard grommet.

REPLACE MASTER SWITCH PANEL DOME LIGHTS LEAD ASSEMBLY (M577A3 AND M1068A3 ONLY) — Continued

0380 00

4. Inspect gasket (11). Replace if damaged.

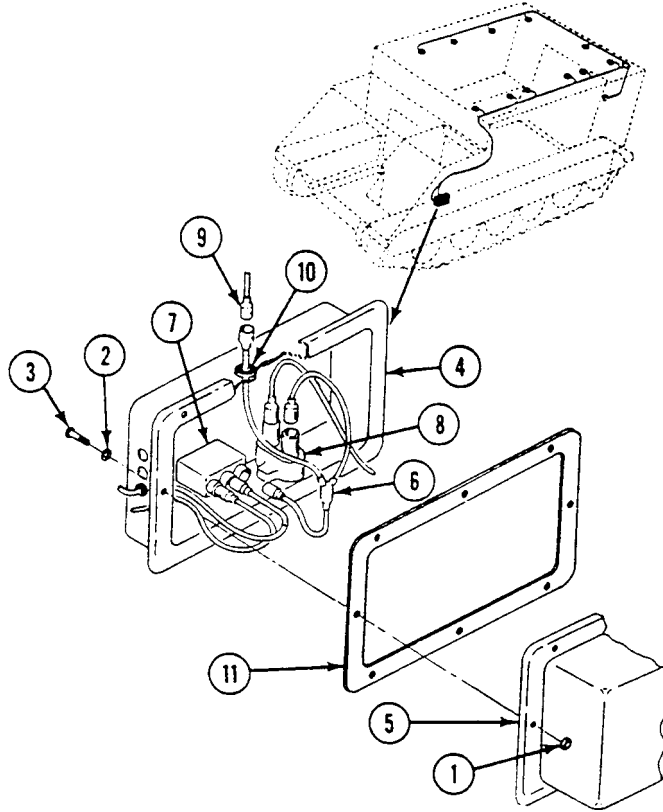

REPLACE MASTER SWITCH PANEL DOME LIGHTS LEAD ASSEMBLY (M577A3 AND M1068A3 ONLY) — Continued

0380 00

INSTALLATION

1. Replace gasket (11) if damaged.
2. Place new grommet (10) on branch of lead assembly (6) that connects to circuit 38E lead (9).
3. Install lead assembly (6) with grommet (10) in master switch panel (4).
4. Connect lead assembly (6) to circuit 38E lead (9), circuit breaker (8), and front dome light switch (7).
5. Place master switch panel (4) on distribution box (5). Secure with eight screws (3), washers (2), and new locknuts (1).

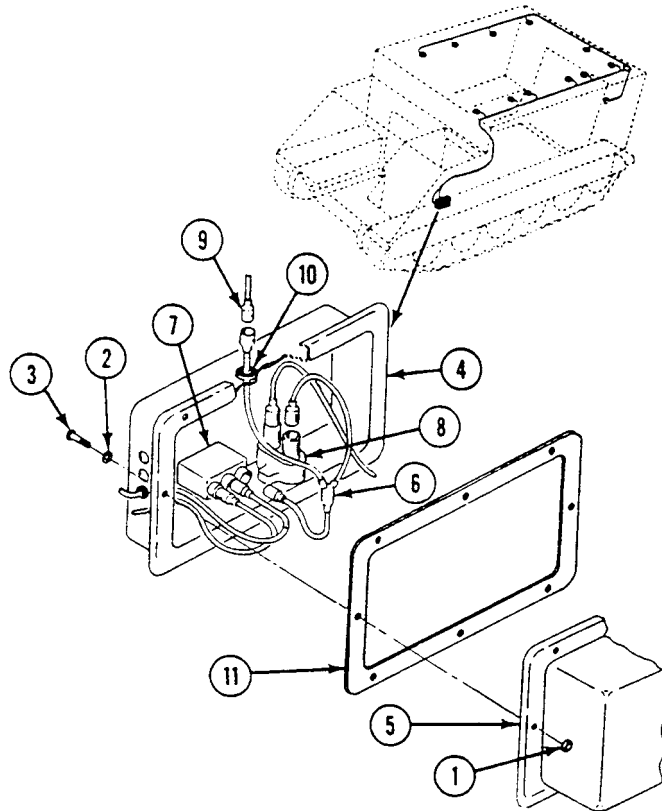
**FOLLOW-THROUGH STEPS**

1. Connect battery ground lead (WP 0338 00).
2. Turn MASTER SWITCH ON (see your -10).
3. Operate dome lights to check that lights operate properly (see your -10).
4. Turn all switches OFF (see your -10).

END OF TASK

REPAIR INTERVEHICLE POWER CABLE (M577A3 AND M1068A3 ONLY)

0381 00

THIS WORK PACKAGE COVERS:

Disassembly (page 0381 00-1).
 Assembly (page 0381 00-2).

INITIAL SETUP:

Maintenance Level

Unit

References

See your -10

Tools and Special Tools

General Mechanic's Tool Kit (WP 0926 00, Item 65)
 Soldering Torch Kit (WP 0926 00, Item 55)

Equipment Condition

Power cable removed from carrier (see your -10)

DISASSEMBLY

1. Remove 12 screws (1), washers (2), and cover (3) from connector (4).

NOTE

Note cable polarity position before removing from connector.

2. Remove four screws (5), washers (6), and two cables (7) from two connectors (4).
3. Remove four terminals, two (-) and two (+), from cables (7).

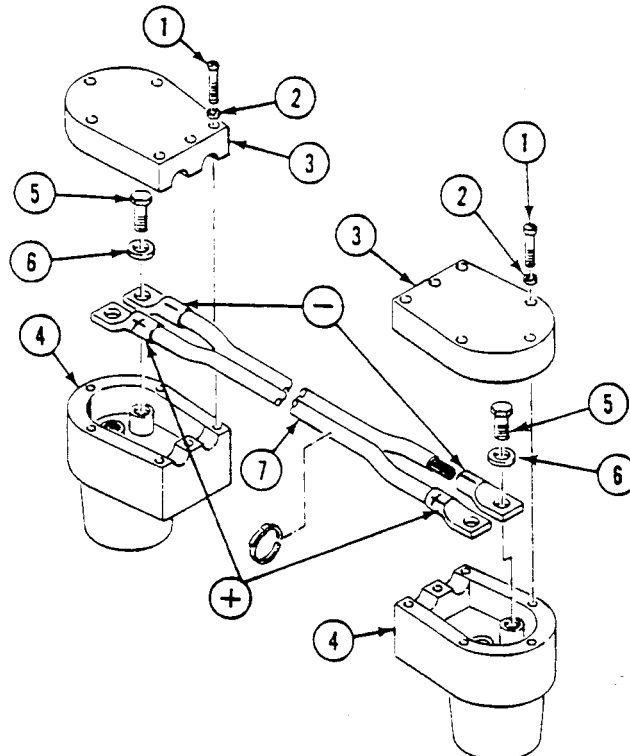

ASSEMBLY

1. Install four terminals, two (-) and two (+), on cables (7).

CAUTION

Do not switch cable polarity when securing cables to connectors.

2. Secure two cables (7) to two connectors (4) with four screws (5) and washers (6).
3. Secure two covers (3) to two connectors (4) with 12 screws (1) and washers (2).

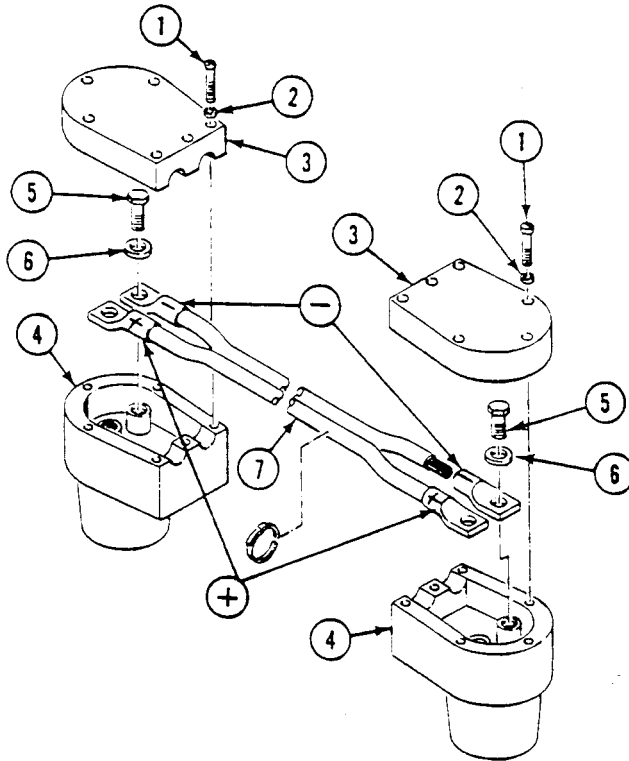
**END OF TASK**

REPAIR WIRING HARNESS

0382 00

THIS WORK PACKAGE COVERS:

Disassembly (page 0382 00-1).
 Assemble (page 0382 00-4).

INITIAL SETUP:

Maintenance Level

Unit

Personnel Required

Unit Mechanic

Tools and Special Tools

General Mechanic's Tool Kit (WP 0926 00, Item 65)
 Electrical Tool Kit (WP 0926 00, Item 64)
 Hacksaw Frame (WP 0926 00, Item 23)
 Electric Gun Heater (WP 0926 00, Item 25)
 Soldering Gun (WP 0926 00, Item 54)

References

See your -10

Materials/Parts

Hacksaw blade (WP 0928 00, Item 36)
 Pin (AR)
 Socket (AR)
 Tin, alloy solder (WP 0928 00, Item 62)
 Terminal (AR)

Equipment Condition

Engine stopped (see your -10)
 Carrier blocked (see your -10)
 Battery ground strap disconnected (WP 0337 00),
 (WP 0338 00), or (WP 0339 00)

DISASSEMBLY

1. Remove male connector from harness lead.
 - a. Slide shell (1) back on lead (2).
 - b. Clip contact pin (3) from lead (2). Discard pin.
 - c. Remove washer (4) or slotted washer (5) and shell (1) from lead (2).

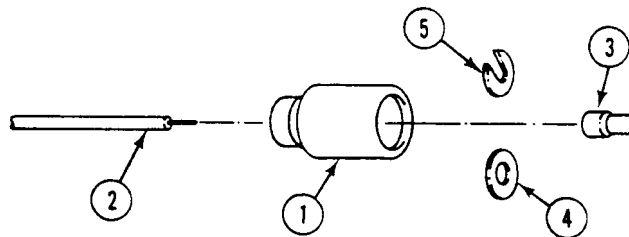

2. Remove female connector from harness lead.
 - a. Slide shell (6) back on lead (7).
 - b. Slide sleeve (8) back from contact socket (9).
 - c. Clip socket (9) from lead (7). Discard socket.

- d. Remove sleeve (8) and shell (6) from lead (7).

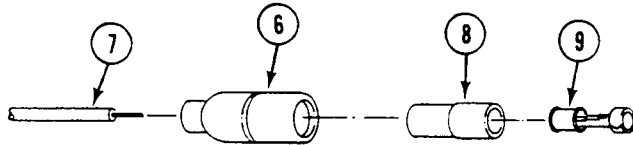

3. Remove terminal connector from harness lead.

- a. If lead (1) has nipple (2), slide nipple back on lead.

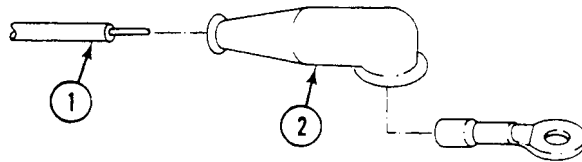

- b. If lead (1) has insulated sleeving (3), cut and discard sleeving from lead.

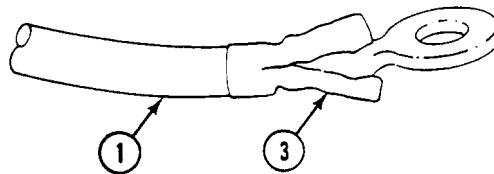

- c. If lead (1) is of large diameter, place in vise (4). Cut lead with hacksaw as close as possible to terminal (5). Discard terminal.

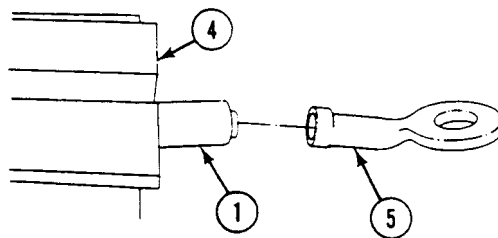

- d. If lead (1) is of small diameter, cut lead as close as possible to terminal (5). Discard terminal.

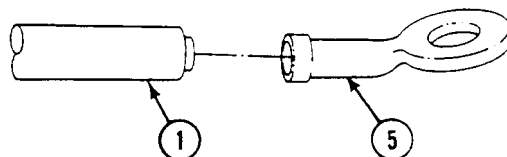

NOTE

Unit Maintenance can only repair multi-pin plugs with up to three sockets. For plugs with more than three sockets, notify your supervisor.

4. Remove multiple connectors the same way as single connectors. Be sure to tag leads to ensure correct installation. See Step 1 and Step 2 above.

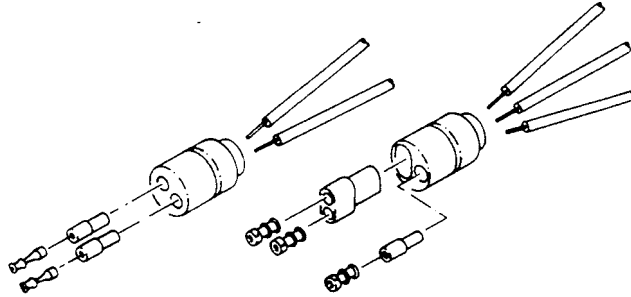

NOTE

For wiring harness repair, it may be necessary to remove Y-type adapters and dummy plugs.

5. Remove Y-type adapter or dummy plug from harness lead.
 - a. Pull harness leads (6) from Y-type adapter (7). Remove adapter.

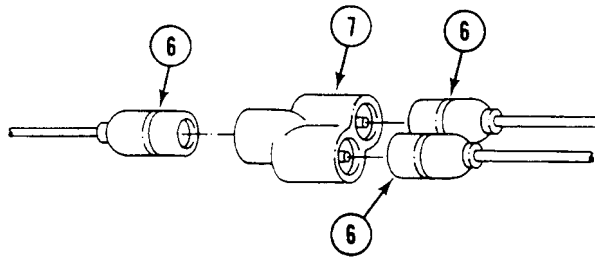

- b. Pull dummy plug (8) from male or female connector (9).



ASSEMBLY

NOTE

If replacing lead, cut new wire from bulk supply. Measure original length, gage, and type of wire.

1. Install male connector on harness lead.
 - a. Strip insulation from lead (1) to uncover just enough wire to fill contact pin well.
 - b. Slide shell (2) and washer (3), if removed, over lead (1).

CAUTION

Crimping lower part of pin may damage pin and it will not hold lead. Crimp only middle part of contact pin with correct size die.

- c. Insert lead (1) into new pin (4) and crimp.
- d. If removed, place slotted washer (5) on lead (1) under pin (4) and pull shell (2) over washer (3) or (5) and pin.

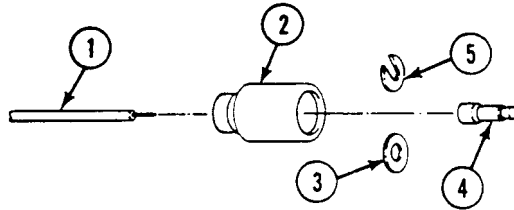

2. Install female connector on harness lead.
 - a. Strip insulation from lead (6) to uncover just enough wire to fill contact socket well.
 - b. Slide shell (7) and sleeve (8) over lead (6).

CAUTION

Crimping lower part of pin may damage pin and it will not hold lead. Crimp only middle part of contact pin with correct size die.

- c. Insert lead (6) in new socket (9) and crimp or solder.
- d. Slide sleeve (8) and shell (7) over socket (9).

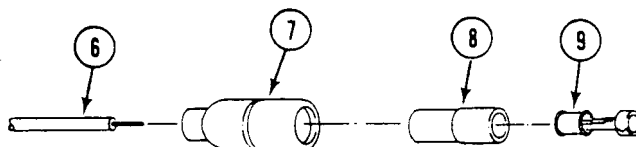

3. Install terminal connector on harness lead.

- a. If nipple (10) was removed from lead (11), strip insulation from lead to uncover just enough wire to fill barrel (12) of terminal (13). Slide nipple over lead.

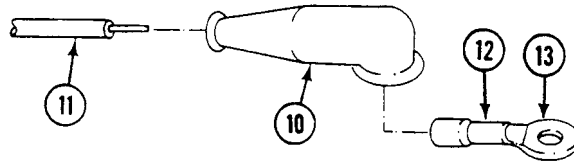

- b. If insulated sleeving (14) was removed from lead (11), slide new insulated sleeving on lead. Strip insulation from lead to same length as barrel (12) on terminal (13).

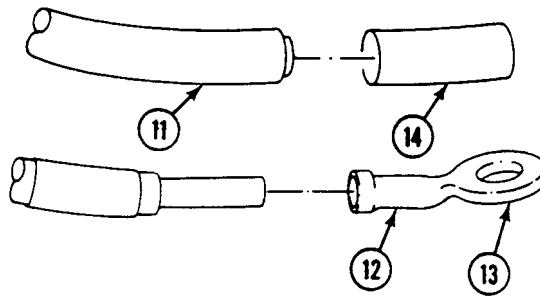

- c. If lead (11) is large diameter, fill barrel (12) on terminal (13) with solder and flux. Insert lead into melted solder in terminal barrel. Allow to cool.

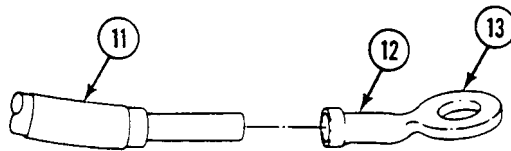

- d. If lead (11) is small diameter, position terminal (13) on lead. Crimp terminal on lead.

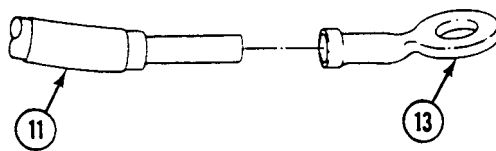

- e. Heat shrink those leads with insulated sleeving (1) on terminal (2).

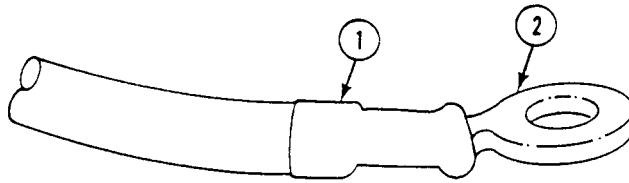

4. Install multiple connectors the same way as single connectors. See Step 1 and Step 2 above.

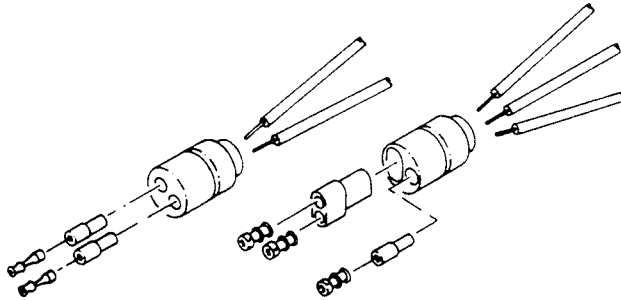

5. If removed, install Y-type adapters and dummy plugs.

- a. Install Y-type adapter (3) on harness leads (4).

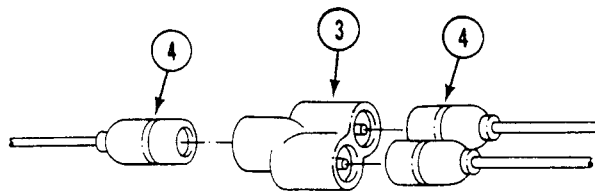

- b. Install dummy plugs (5) in male or female connector (6).



FOLLOW-THROUGH STEPS

1. Connect battery ground strap (WP 0337 00), (WP 0338 00), or (WP 0339 00).
2. Turn MASTER SWITCH to ON (see your -10).
3. Check for proper wiring harness repair.
4. Turn MASTER SWITCH to OFF (see your -10).

END OF TASK

REPLACE VENTILATION FAN (M577A3 AND M1068A3 ONLY)

0383 00

THIS WORK PACKAGE COVERS:

Removal (page 0383 00-1).
 Installation (page 0383 00-3).

INITIAL SETUP:

Maintenance Level

Unit

References

See your -10

Tools and Special Tools

General Mechanic's Tool Kit (WP 0926 00, Item 65)

Equipment Condition

Engine stopped (see your -10)
 Carrier blocked (see your -10)
 Battery access cover removed (see your -10)
 Battery ground lead disconnected (WP 0338 00)
 Power plant rear access panel removed (see your -10)

Materials/Parts

Locknuts (6)
 Locknuts (3)

Personnel Required

Unit Mechanic

REMOVAL

1. Disconnect blower lead (1) from circuit 59 lead (2).
2. Remove six locknuts (3), washers (4), screws (5), and adapter (6) with blower (7) attached, from flapper valve (8). Discard locknuts.

3. Remove three locknuts (9), screws (10), and adapter (6) from blower (7). Discard locknuts.

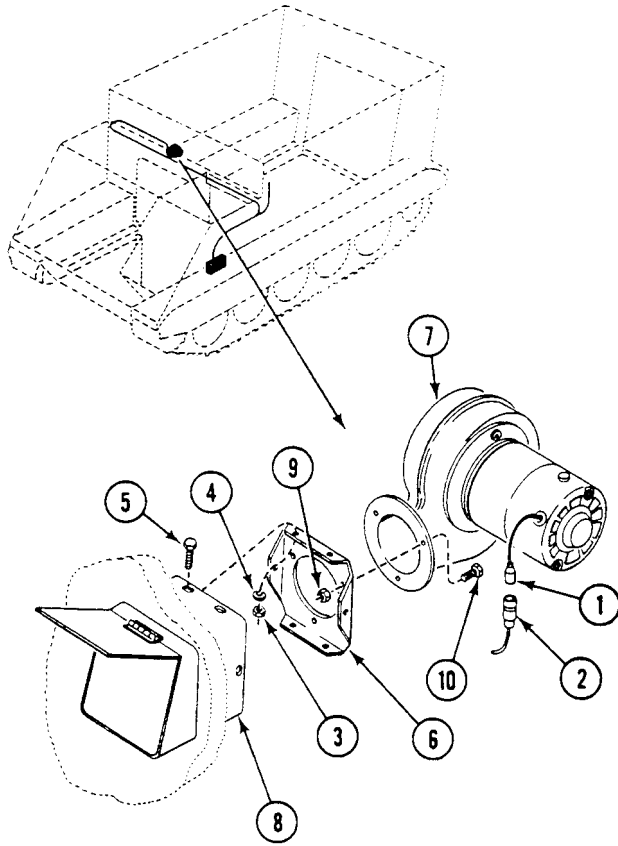

INSTALLATION

1. Install adapter (6) on blower (7). Secure with three screws (10) and new locknuts (9).
2. Install adapter (6) and blower (7) on flapper valve (8). Secure with six screws (5), washers (4), and new locknuts (3).
3. Connect circuit 59 lead (2) to blower lead (1).

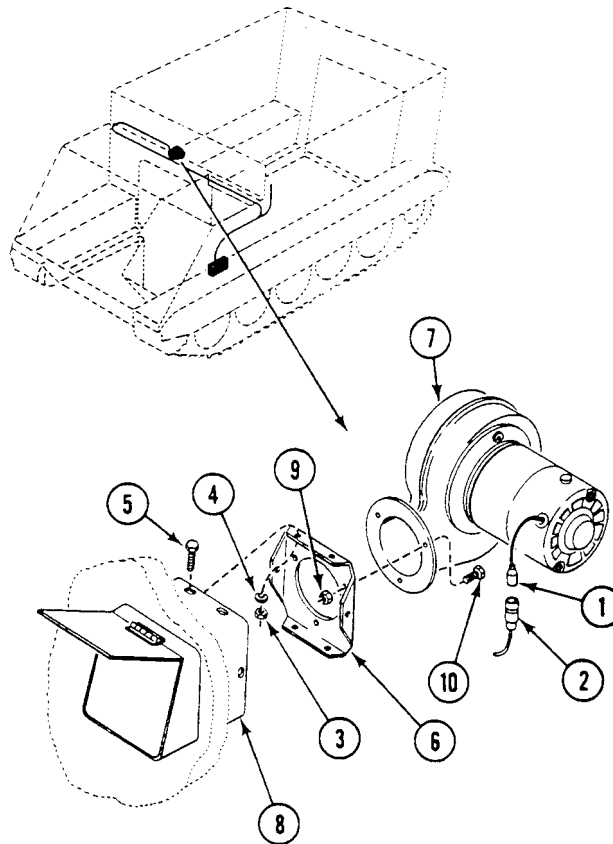

FOLLOW-THROUGH STEPS

1. Connect battery ground lead (WP 0338 00).
2. Install battery access cover (see your -10).
3. Turn MASTER SWITCH and BLOWER switch ON to check that fan operates properly (see your -10).
4. Turn all switches OFF (see your -10).
5. Install power plant rear access panel (see your -10).

END OF TASK

CHAPTER 9

UNIT MAINTENANCE INSTRUCTIONS
FOR TRANSMISSION

WORK PACKAGE INDEX

<u>Title</u>	<u>Sequence No.</u>
REPLACE TRANSMISSION OIL DRAIN TUBES AND BRACKET.....	.0384 00
REPLACE TRANSMISSION MOUNTS.....	.0385 00
REPLACE TRANSMISSION RANGE CONTROLLER/BRACKET (USED WITH SOLENOID-ACTIVATED STEERING LOCK).....	.0386 00
REPLACE TRANSMISSION RANGE CONTROLLER/BRACKET (USED WITH CABLE-ACTIVATED STEERING LOCK).....	.0387 00
REPLACE TRANSMISSION RANGE CONTROLLER LAMP.....	.0388 00
REPLACE TRANSMISSION RANGE CONTROLLER SWITCH.....	.0389 00
ADJUST TOW START CONTROL CABLE ASSEMBLY.....	.039000
REPLACE TOW START CONTROL ASSEMBLY AND BEARING.....	.0391 00
REPLACE TOW START CONTROL ASSEMBLY COVER.....	.0392 00
ADJUST TRANSMISSION STEERING.....	.0393 00
ADJUST TRANSMISSION BRAKES.....	.0394 00
REPLACE TRANSMISSION OIL LEVEL DIPSTICK, FILLER TUBE, AND ADAPTER (X200-4 ONLY).....	.0395 00
REPLACE TRANSMISSION OIL LEVEL DIPSTICK, FILLER TUBE, AND ADAPTER (X200-4A ONLY).....	.0396 00
REPLACE GOVERNOR ASSEMBLY.....	.0397 00
REPLACE TRANSMISSION OIL AND OIL FILTER ELEMENT.....	.0398 00
REPLACE TRANSMISSION OIL COOLER HOSES, FITTINGS, AND MOUNTING.....	.0399 00
REPLACE TRANSMISSION OIL SAMPLING VALVE AND PRESSURE SWITCH.....	.0400 00
REPLACE DIFFERENTIAL PRESSURE SWITCH AND BYPASS PLUG.....	.0401 00

REPLACE TRANSMISSION OIL DRAIN TUBES AND BRACKET

0384 00

THIS WORK PACKAGE COVERS:

Removal (page 0384 00-1).
 Installation (page 0384 00-2).

INITIAL SETUP:

Maintenance Level

Unit

References

See your -10

Tools and Special Tools

General Mechanic's Tool Kit (WP 0926 00, Item 65)

Materials/Parts

Nonmetallic hose (WP 0928 00, Item 43)
 Locknut
 Lockwasher
 Preformed packing

Equipment Condition

Engine stopped (see your -10)
 Carrier blocked (see your -10)
 Power plant removed (WP 0156 00)
 Transmission oil drained (WP 0398 00)

Personnel Required

Unit Mechanic

REMOVAL

1. Remove locknut (1), screw (2), washer (3), and clamp (4) from bracket (5). Discard locknut.
2. Remove coupling nut (6) and oil drain tube (7) from adapter (8).
3. Remove two clamps (9) from hose (10). Remove hose from tubes (7) and (11). Discard hose.

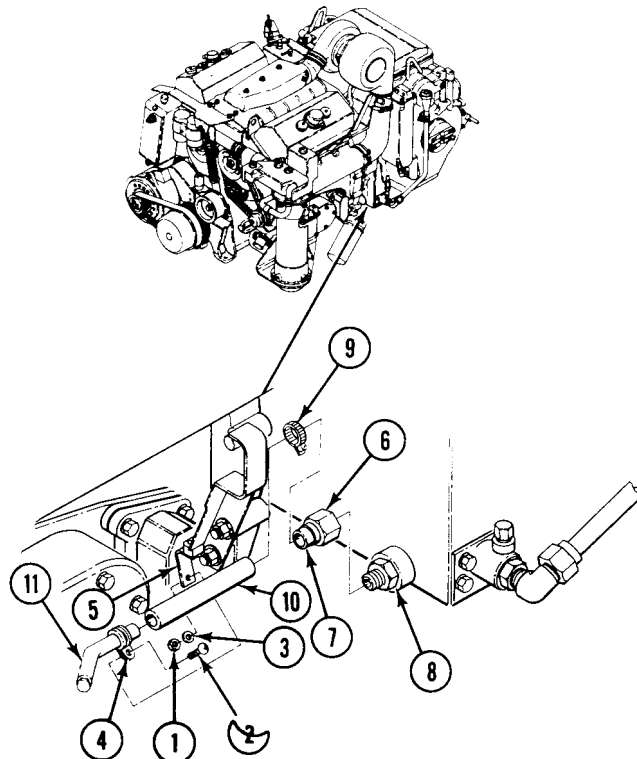

4. Remove drain plug (1) and clamp (2) from tube (3).
5. Remove screw (4), lockwasher (5), and bracket (6) from bracket (7). Discard lockwasher.

INSTALLATION

1. Install bracket (6) on bracket (7). Secure with new lockwasher (5), and screw (4).
2. Install drain plug (1) and clamp (2) on tube (3).

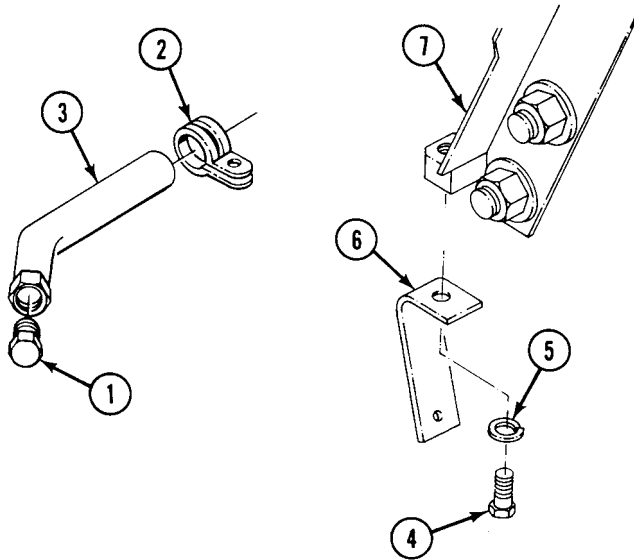

3. Cut 5-1/4 (13 cm) inch new hose (8) from rubber hosing. Install two clamps (9) on hose (8). Install hose on two tubes (3) and (10). Tighten clamps.
4. Install tube (10) on adapter (11). Tighten coupling nut (12).
5. Install clamp (2) on bracket (6). Secure with screw (13), washer (14), and new locknut (15).

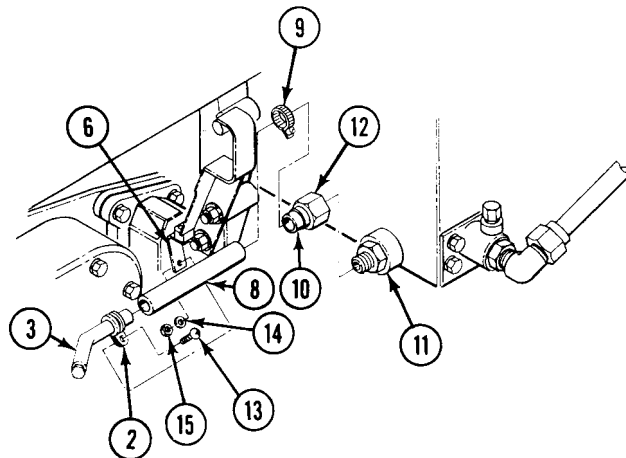

FOLLOW-THROUGH STEPS

1. Fill transmission with oil (WP 0398 00).
2. Install power plant (WP 0156 00).

END OF TASK

REPLACE TRANSMISSION MOUNTS

0385 00

THIS WORK PACKAGE COVERS:

Removal (page 0385 00-1).
 Installation (page 0385 00-3).

INITIAL SETUP:

Maintenance Level

Unit

References

See your -10

Tools and Special Tools

General Mechanic's Tool Kit (WP 0926 00, Item 65)
 Torque Wrench (WP 0926 00, Item 85)

Equipment Condition

Engine stopped (see your -10)
 Carrier blocked (see your -10)
 Power plant grill raised (WP 0464 00)
 Power plant removed (WP 0156 00)

Personnel Required

Unit Mechanic

REMOVAL

NOTE

Both lower mounts are removed the same way.

1. Remove two screws (1) and washers (2) from lower mount (3) and carrier main frame.

2. Remove lower mount (3) from carrier main frame.

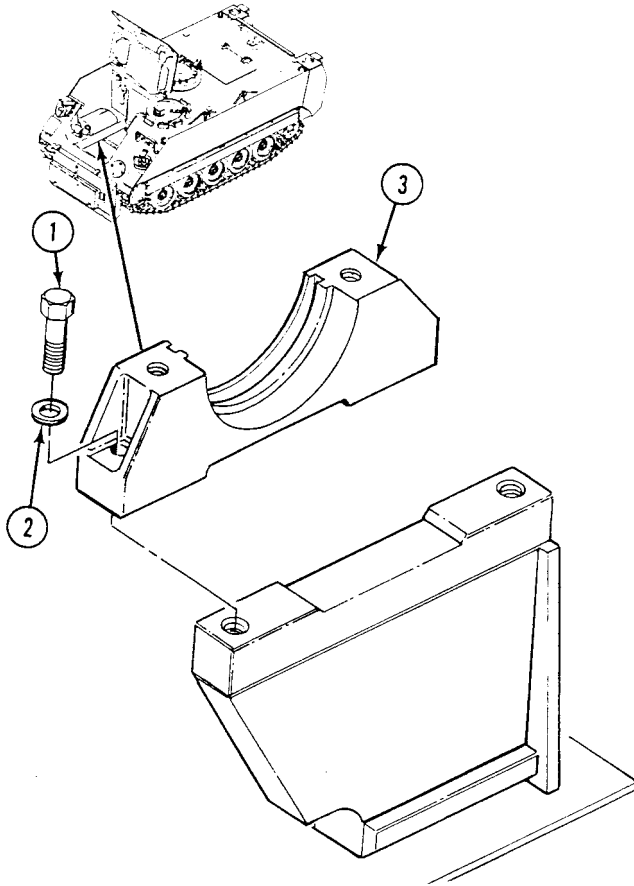

INSTALLATION

NOTE

Right transmission mount is grooved.

Upper and lower mounts are matched sets. Do not mix.

1. Install lower mount (3) on carrier main frame with two screws (1) and washers (2). TIGHTEN SCREWS TO 86-94 LB-FT (116-127 N·m) torque.

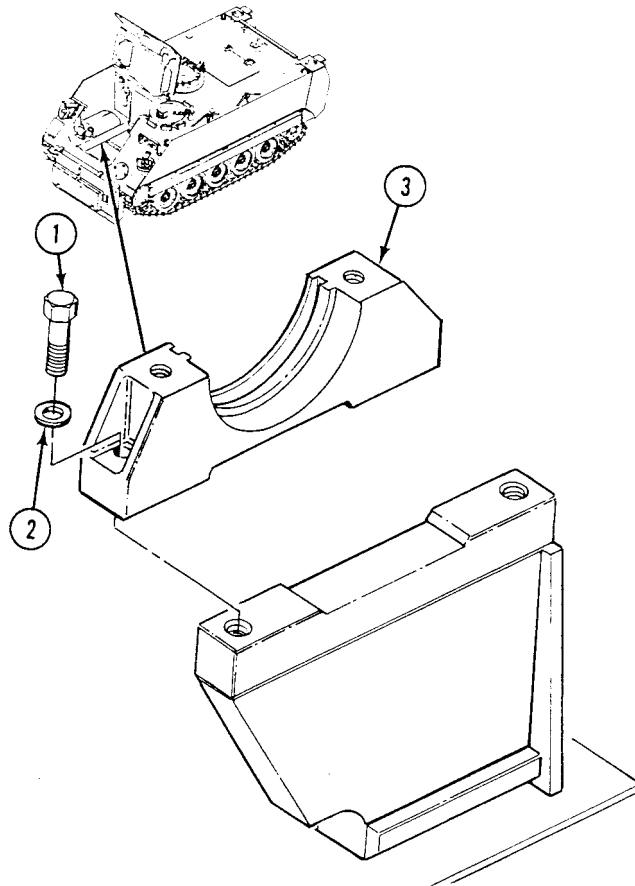

FOLLOW-THROUGH STEPS

1. Install power plant (WP 0156 00).
2. Lower power plant grill (WP 0464 00).

END OF TASK

REPLACE TRANSMISSION RANGE CONTROLLER/BRACKET (USED WITH SOLENOID-ACTIVATED STEERING LOCK) 0386 00

THIS WORK PACKAGE COVERS:

Removal (page 0386 00-1).
 Installation (page 0386 00-3).

INITIAL SETUP:

Maintenance Level

Unit

References

See your -10

Tools and Special Tools

General Mechanic's Tool Kit (WP 0926 00, Item 65)

Equipment Condition

Engine stopped (see your -10)

Materials/Parts

Lockwasher (8)

Locknut (3)

Carrier blocked (see your -10)

Personnel Required

Unit Mechanic

Drivers power plant access panel removed (see your -10)

REMOVAL

1. Remove four screws (1), lockwashers (2), and washers (3) that secure mounts (4) to bracket (5). Discard lockwashers.

REPLACE TRANSMISSION RANGE CONTROLLER/BRACKET (USED WITH SOLENOID-ACTIVATED STEERING LOCK) — Continued

0386 00

2. Remove four screws (6), lockwashers (7), washers (8), and four mounts (4) from controller (9). Discard lockwashers.
3. Disconnect wiring harness (10) from controller (9).
4. Remove three screws (11), six washers (12), and three locknuts (13) that secure bracket (5) to bulkhead. Remove bracket. Discard locknuts.

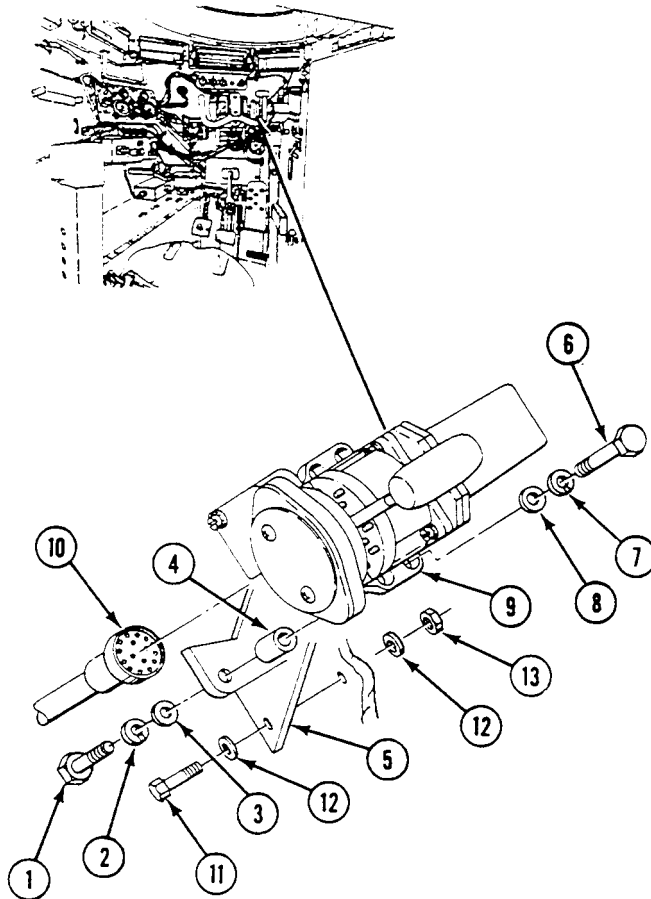

REPLACE TRANSMISSION RANGE CONTROLLER/BACKET (USED WITH SOLENOID-ACTIVATED STEERING LOCK) — Continued

0386 00

INSTALLATION

1. Connect wiring harness (10) to controller (9).
2. Install bracket (5) on bulkhead. Secure with three screws (11), six washers (12), and three new locknuts (13).
3. Install four mounts (4) on controller (9) and secure with four screws (6), new lockwashers (7), and washers (8).
4. Install controller (9) with four mounts (4) on bracket (5). Secure with four screws (1), new lockwashers (2), and washers (3).

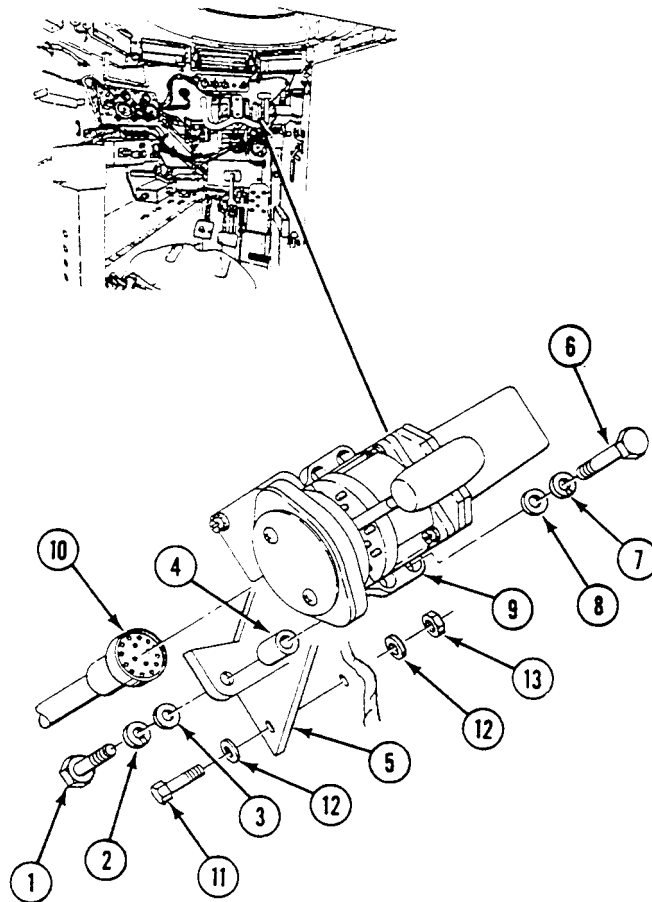
**FOLLOW-THROUGH STEPS**

1. Install drivers power plant access panel (see your -10).

END OF TASK

**REPLACE TRANSMISSION RANGE CONTROLLER/BRACKET (USED WITH
CABLE-ACTIVATED STEERING LOCK)**

0387 00

THIS WORK PACKAGE COVERS:

Removal (page 0387 00-1).
Installation (page 0387 00-3).

INITIAL SETUP:

Maintenance Level

Unit

Personnel Required

Unit Mechanic

Tools and Special Tools

General Mechanic's Tool Kit (WP 0926 00, Item 65)

References

See your -10

Materials/Parts

Cotter pin
Locknut (3)
Lockwasher
Lockwasher (8)

Equipment Condition

Engine stopped (see your -10)
Carrier blocked (see your -10)
Driver's power plant access panel
removed (see your -10)

REMOVAL

1. Remove cotter pin (1), two washers (2), pin (3), and end of push-pull assembly (4) from controller arm (5). Discard cotter pin.

**REPLACE TRANSMISSION RANGE CONTROLLER/BACKET (USED WITH
CABLE-ACTIVATED STEERING LOCK) — Continued**

0387 00

2. Remove nut (6) and lockwasher (7) from end of push-pull assembly (4), and remove push-pull assembly from bracket (8). Reinstall nut (6) on push-pull assembly (4) for future use. Discard lockwasher.
3. Remove four screws (9), lockwashers (10), washers (11), and controller (12) from four mounts (13). Discard lockwashers.
4. Remove four screws (14), lockwashers (15), washers (16), and mounts (13) from bracket (17). Discard lockwashers.

NOTE

Install covers on disconnected electrical cable connectors and components during maintenance. Use tape, cloth, cardboard, or any appropriate material to prevent damage to components.

5. Disconnect wiring harness (18) from controller (12).
6. Remove three screws (19), six washers (20), three locknuts (21), and bracket (17) from bulkhead. Discard locknuts.

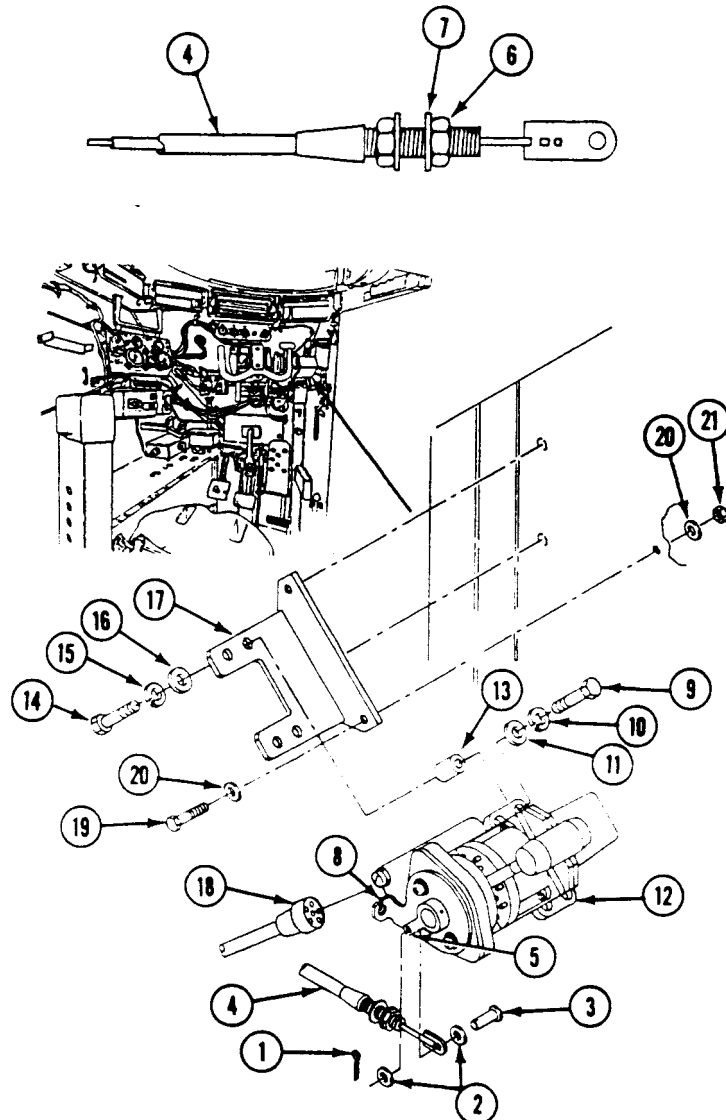

**REPLACE TRANSMISSION RANGE CONTROLLER/BACKET (USED WITH
CABLE-ACTIVATED STEERING LOCK) — Continued**

0387 00

INSTALLATION

1. Install bracket (1) on bulkhead. Secure with three screws (2), six washers (3), and three new locknuts (4).
2. Connect wiring harness (5) to controller (6).
3. Install four mounts (7) on bracket (1). Secure with four screws (8), new lockwashers (9), and washers (10).
4. Install controller (6) on four mounts (7). Secure with four screws (11), new lockwashers (12), and washers (13).

NOTE

Do not tighten jamnuts until all parts to the cable and mechanical steering lock are fully assembled and adjusted.

5. Remove nut (14) from push-pull assembly (15) and insert end of push-pull assembly into hole in bracket (16). Secure with nut (14) and new lockwasher (17).
6. Secure end of push-pull assembly (15) to controller arm (18) with pin (19), two washers (20), and new cotter pin (21).

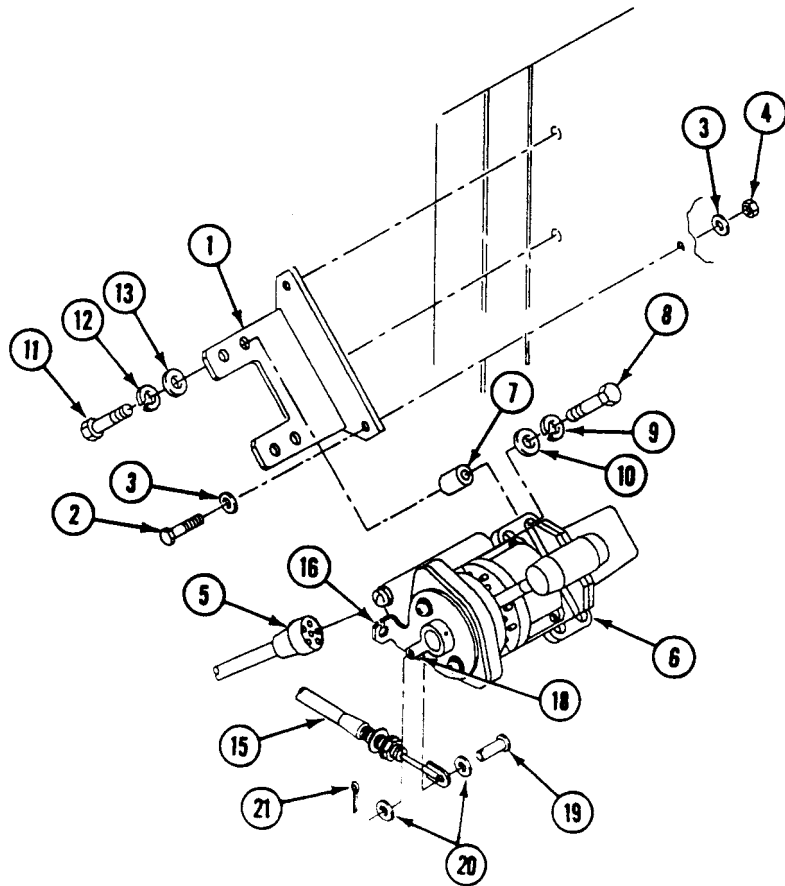

**REPLACE TRANSMISSION RANGE CONTROLLER/BRACKET (USED WITH
CABLE-ACTIVATED STEERING LOCK) — Continued**

0387 00

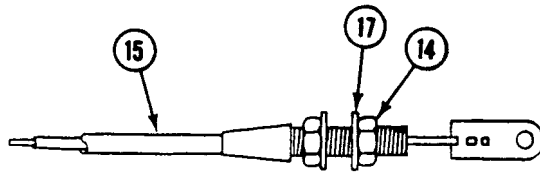
**FOLLOW-THROUGH STEPS**

1. Install driver's power plant access panel (see your -10).
2. Adjust cable-activated steering lock (WP 0429 00).

END OF TASK

REPLACE TRANSMISSION RANGE CONTROLLER LAMP

0388 00

THIS WORK PACKAGE COVERS:

Removal (page 0388 00-1).
 Installation (page 0388 00-2).

INITIAL SETUP:

Maintenance Level
 Unit

References
 See your -10

Tools and Special Tools
 General Mechanic's Tool Kit
 (WP 0926 00, Item n5180001777033)

Equipment Condition

Materials/Parts
 Preformed packing

Engine stopped (see your -10)
 Carrier blocked (see your -10)
 Transmission range controller removed (WP 0386 00) or
 (WP 0387 00)

Personnel Required
 Unit Mechanic

REMOVAL

1. Remove two wing screws (1) from cover (2) and back of range controller (3). Carefully pull cover away from range controller until lamp (4), filter (5), and shield (6) are accessible.
2. Loosen screw (7) and nut (8) until lamp (4), filter (5), and shield (6) can be removed from clamp (9). Remove filter, shield, and lamp.
3. Remove preformed packing (10) from lamp (4). Discard packing.

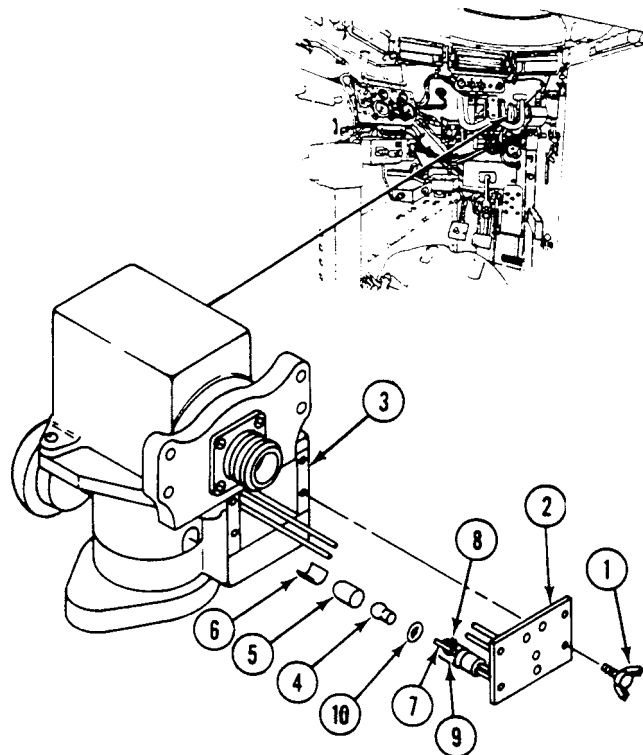

INSTALLATION

1. Install new preformed packing (10) on lamp (4).
2. Install lamp (4) into clamp (9).
3. Place filter (5) and shield (6) properly over lamp (4). Secure by tightening screw (7) and nut (8) on clamp (9).
4. Install cover (2) on range controller (3). Secure with two wing screws (1).

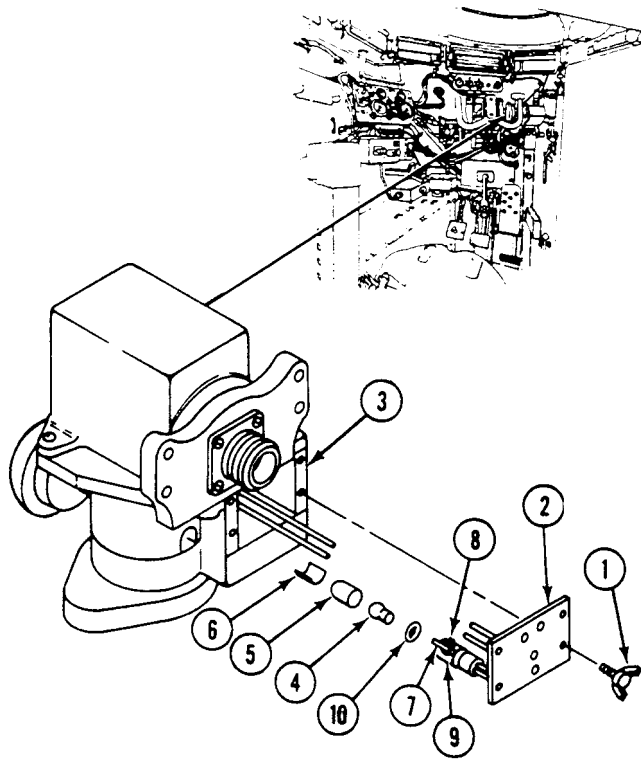
**FOLLOW-THROUGH STEPS**

1. Install transmission range controller (WP 0386 00) or (WP 0387 00).

END OF TASK

REPLACE TRANSMISSION RANGE CONTROLLER SWITCH

0389 00

THIS WORK PACKAGE COVERS:

- Removal (page 0389 00-1).
- Cleaning (page 0389 00-1).
- Installation (page 0389 00-2).

INITIAL SETUP:

Maintenance Level

Unit

References

See your -10

Tools and Special Tools

General Mechanic's Tool Kit (WP 0926 00, Item 65)

Equipment Condition

Engine stopped (see your -10)

Materials/Parts

Cleaning compound solvent (WP 0928 00, Item 19)

Sealing compound (WP 0928 00, Item 56)

Carrier blocked (see your -10)

Personnel Required

Unit Mechanic

Transmission range controller removed (WP 0386 00) or (WP 0387 00)

REMOVAL

1. Remove three slotted screws (4) securing switch (3) to transmission range controller body (1).

NOTE

Do not bend the switch bracket too much until it is clear of the transmission controller body.

2. Separate switch (3) from transmission range controller (1).

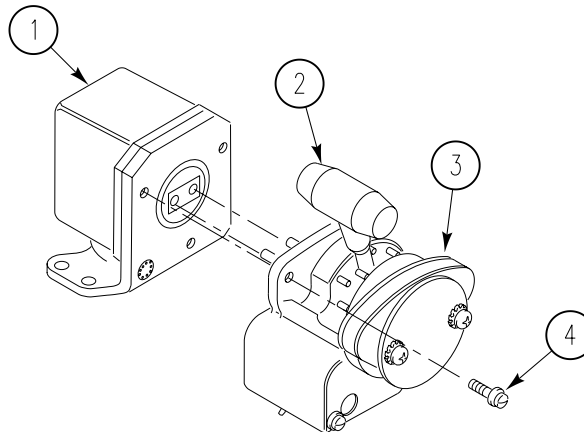

CLEANING

CAUTION

Handle the new switch with care to avoid damaging the wires or switch. A damaged transmission controller will prevent the engine from starting or shifting to the range needed.

1. Clean any corrosion to the inside of the transmission range controller body (1) where it contacts the slotted adapter on the switch (3).

INSTALLATION

1. Align the two pins on the transmission controller body (1) into the socket on the switch (3) and begin to insert.
2. Adjust the shift handle (2) on transmission controller body (1) to align the tab with the slot before closing the switch (3) and transmission controller body together.
3. Apply cleaning compound and sealing compound to threads of three slotted screws (4).
4. Install three slotted screws (4), but do not tighten until you are sure shifter (2) is moving the switch (3). Tighten screws .

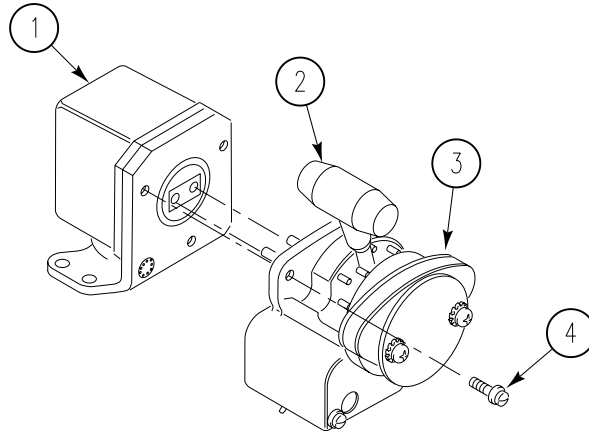
**FOLLOW-THROUGH STEPS**

1. Install transmission range controller (WP 0386 00) or (WP 0387 00).

END OF TASK

ADJUST TOW START CONTROL CABLE ASSEMBLY

0390 00

THIS WORK PACKAGE COVERS:

Adjustment (page 0390 00-1).

INITIAL SETUP:

Maintenance Level

Unit

Equipment Condition

Engine stopped (see your -10)

Carrier blocked (see your -10)

Trim vane lowered (see your -10)

Power plant front access door open (see your -10)

Tools and Special Tools

General Mechanic's Tool Kit (WP 0926 00, Item 65)

Personnel Required

Unit Mechanic

References

See your -10

ADJUSTMENT

1. Loosen two setscrews (1) that secure two collars (2) on control cable (3).

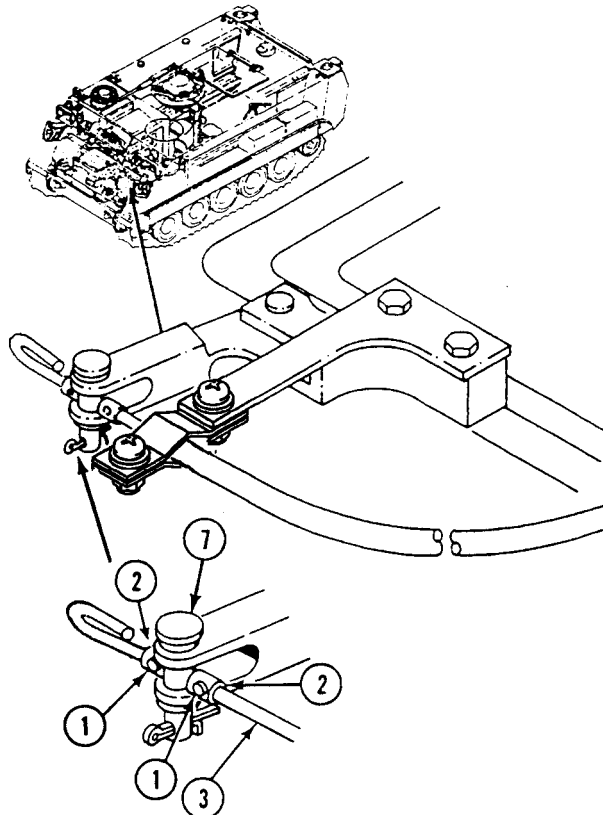

2. Push control assembly handle (4) to full in position. Move control lever (5) to obtain 0.00 to 0.06 inch (0.00 to 1.5 mm) clearance between contact surface of lever and transmission tow start button (6).

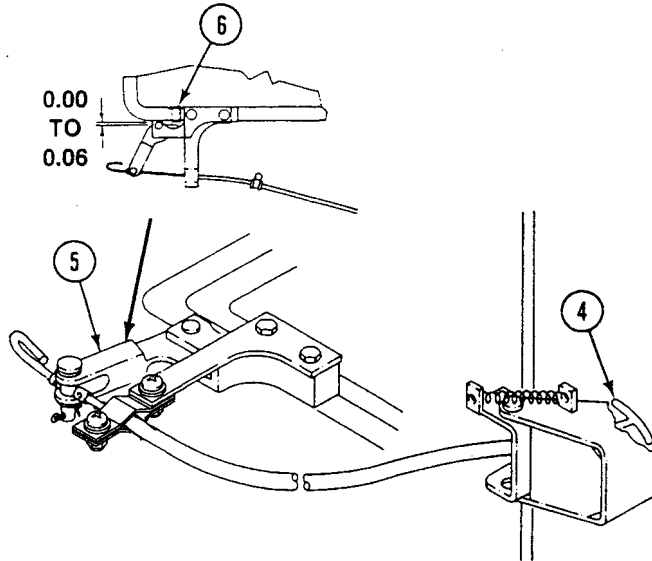

3. Position two collars (2) against clevis pin (7) and tighten two setscrews (1).

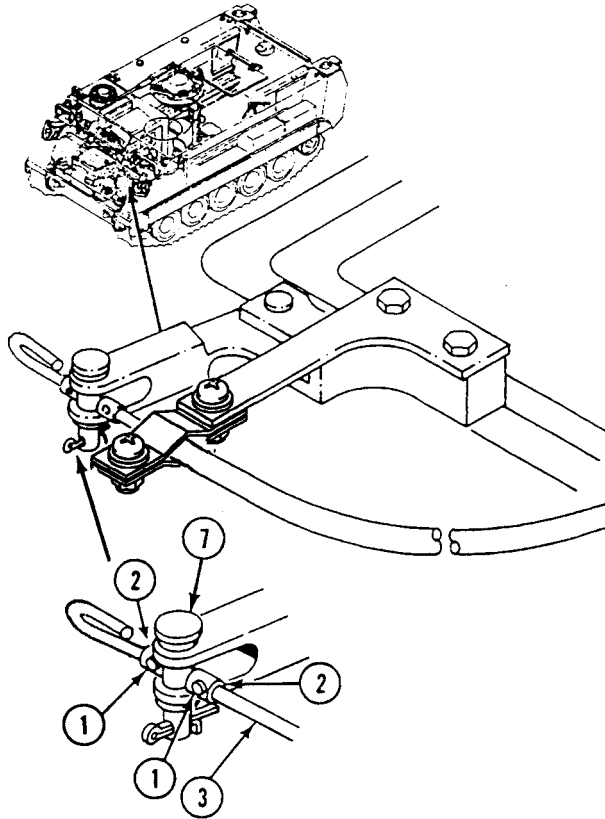

FOLLOW-THROUGH STEPS

1. Close power plant front access door (see your -10).
2. Raise trim vane (see your -10).

END OF TASK

REPLACE TOW START CONTROL ASSEMBLY AND BEARING

0391 00

THIS WORK PACKAGE COVERS:

Removal (page 0391 00-2).
 Installation (page 0391 00-5).

INITIAL SETUP:

Maintenance Level

Unit

References

See your -10

Tools and Special Tools

General Mechanic's Tool Kit (WP 0926 00, Item 65)
 Socket Wrench Set (WP 0926 00, Item 72)
 Torque Wrench (WP 0926 00, Item 82)

Equipment Condition

Engine stopped (see your -10)

Carrier blocked (see your -10)

Trim vane lowered (see your -10)

Materials/Parts

Cotter pin (2)
 Locknut

Power plant front access door open (see your -10)

Personnel Required

Unit Mechanic

REMOVAL

NOTE

Wire is doubled over itself as a safety measure. If there is nothing wrong or defective with cable assembly or control lever, DO NOT straighten or cut wire.

1. Straighten out wire (1) or cut off wire to allow it to be removed. If too much wire is removed, discard cable assembly after removal from bulkhead.
2. Loosen front setscrew (2) that secures front collar (3) to end of cable assembly (4). Pull cable out of clevis pin (5) and loosen rear setscrew (6) on rear collar (7). Remove front and rear collar from cable assembly.
3. Remove cotter pin (8) and two washers (9) that secure clevis pin (5) to control lever (10). Remove clevis pin from control lever. Discard cotter pin.

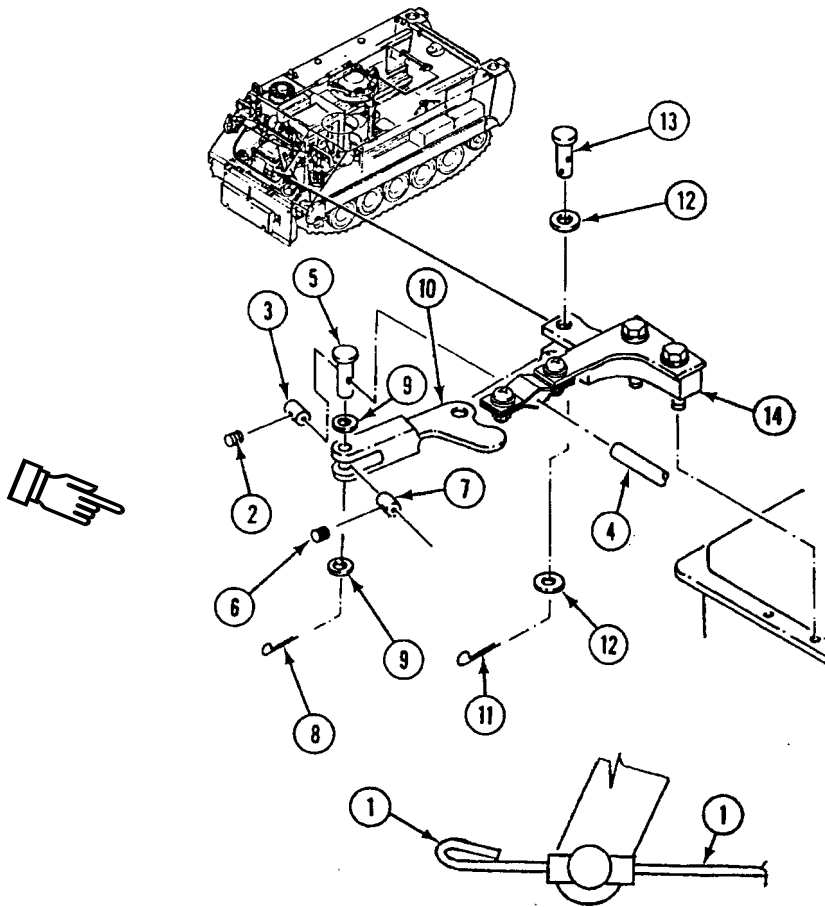

4. Remove cotter pin (11), two washers (12), and clevis pin (13) that secure control lever (10) to bearing (14). Remove control lever from bearing. Discard cotter pin.

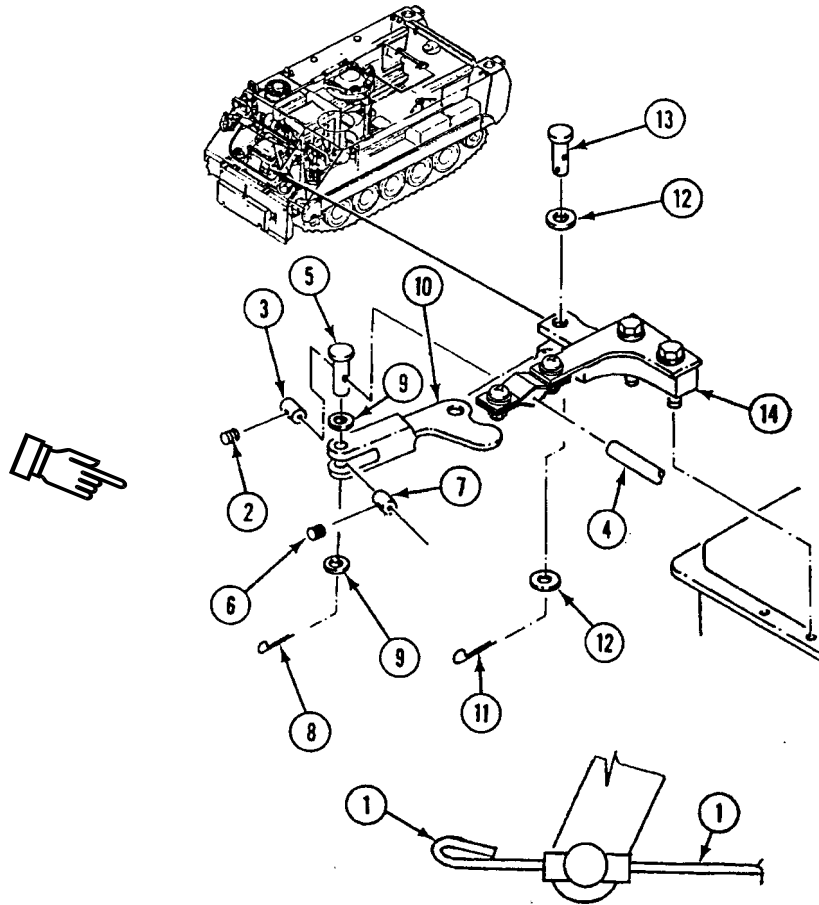

5. Remove two straps (1), screws (2), washers (3), and locknuts (4) that secure cable assembly (5) to cable bracket (6). Remove straps from cable. Discard locknuts.
6. Remove two screws (7) and washers (8) that secure cable bracket (6) and bearing (9) to top of transmission. Remove bracket and bearing from transmission.

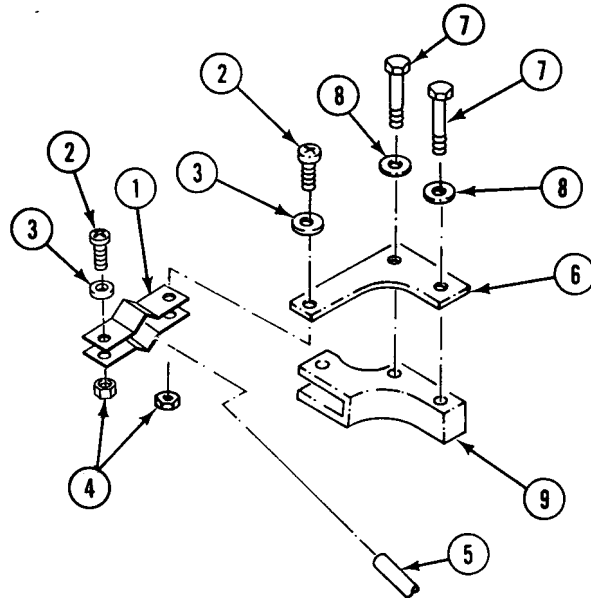

7. Remove jam nut (10) and washer (11) from lower end on threaded cable conduit that secures cable assembly (12) in engine compartment. Remove or discard cable assembly if wire is too short to be secured by collars and wire bent over itself.

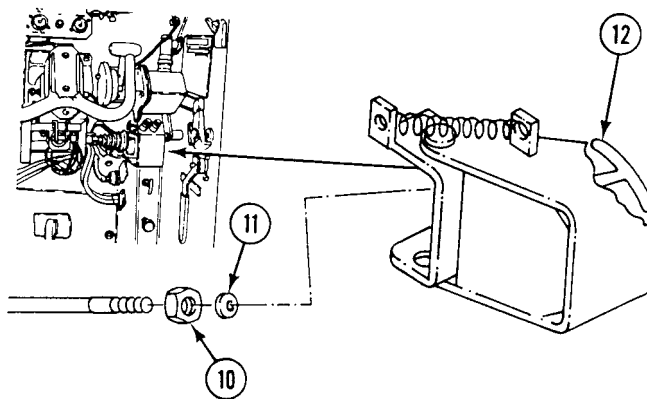

INSTALLATION

1. Route cable assembly (12) from driver's compartment through mounting hole in bulkhead.
2. Install jam nut (10) and washer (11) on threaded conduit end of control cable assembly (12). Tighten jam nut.

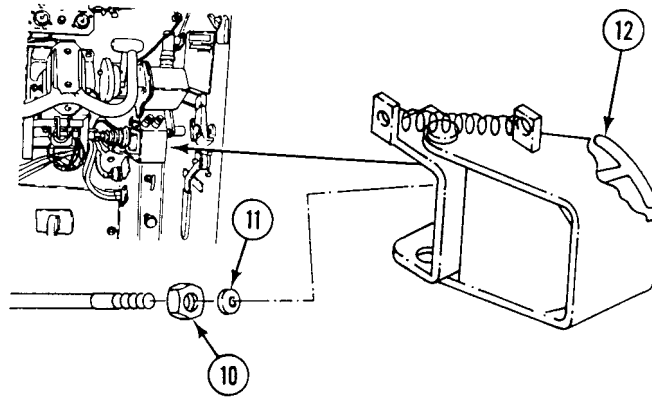

3. Install cable bracket (6) and bearing (9) on top of transmission. Secure with two screws (7) and washers (8). **TIGHTEN SCREWS TO 18-20 LB-FT (24-27 N·m) TORQUE.**
4. Place two cable straps (1) on conduit end of cable assembly (5). Install cable straps with cable assembly on bracket (6). Secure with two screws (2), washers (3), and new locknuts (4).

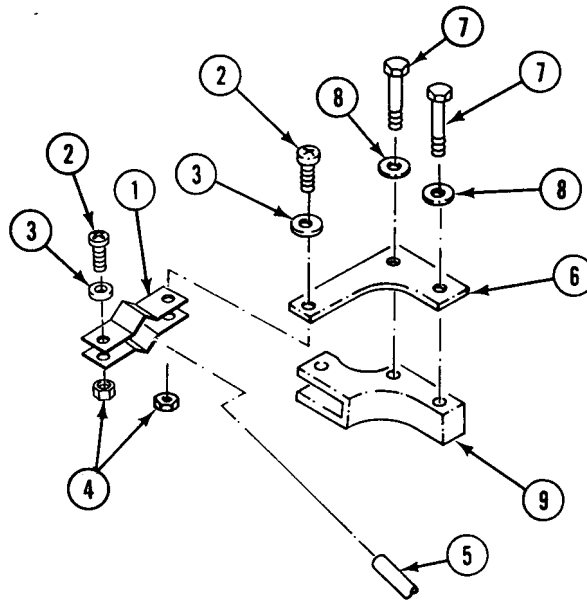

5. Install control lever (1) into bearing (2). Secure with clevis pin (3), two washers (4), and new cotter pin (5).
6. Install clevis pin (6) on control lever (1). Secure with two washers (7) and new cotter pin (8).
7. Install rear collar (9) with rear setscrew (10) onto cable end of cable assembly (11). Insert end of cable through mounting hole on clevis pin (6). Install front collar (12) with front setscrew (13) on cable assembly.
8. Push control handle to full in position. Move lever (1) until contact is made with surface of tow start button (14). Adjust tow start button (14).
9. Tighten setscrews (10) and (13).

WARNING

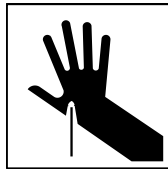

Sharp wire end can injure hands. Make sure wire (15) is doubled over as a safety measure.

10. Double wire (15) over itself 1/4 inch (6 mm) minimum, as shown.

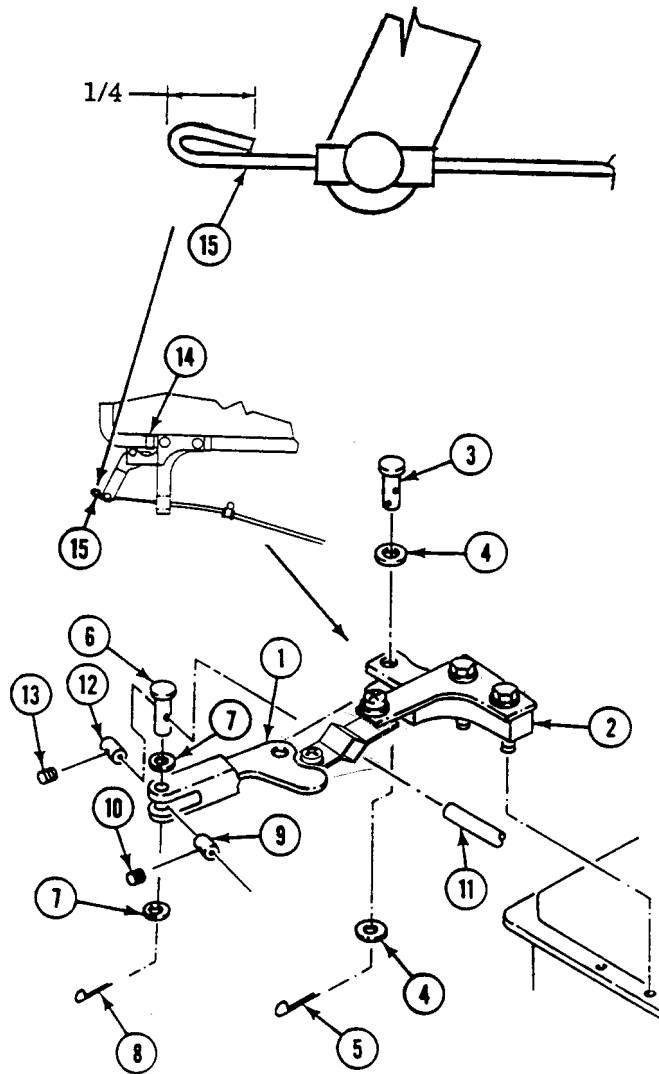

FOLLOW-THROUGH STEPS

1. Close power plant front access door (see your -10).
2. Raise trim vane (see your -10).

END OF TASK

REPLACE TOW START CONTROL ASSEMBLY COVER

0392 00

THIS WORK PACKAGE COVERS:

Removal (page 0392 00-1).
 Installation (page 0392 00-2).

INITIAL SETUP:

Maintenance Level

Unit

Personnel Required

Unit Mechanic

Tools and Special Tools

General Mechanic's Tool Kit (WP 0926 00, Item 65)

References

See your -10

Materials/Parts

Cotter pin
 Cover
 Marker

Equipment Condition

Engine stopped (see your -10)
 Carrier blocked (see your -10)

REMOVAL

1. Remove spring (1) from cover (2) and bulkhead welded bracket (3).
2. Remove cotter pin (4), two washers (5), pin (6), and control cover (2) from bulkhead welded bracket (3). Discard cotter pin.

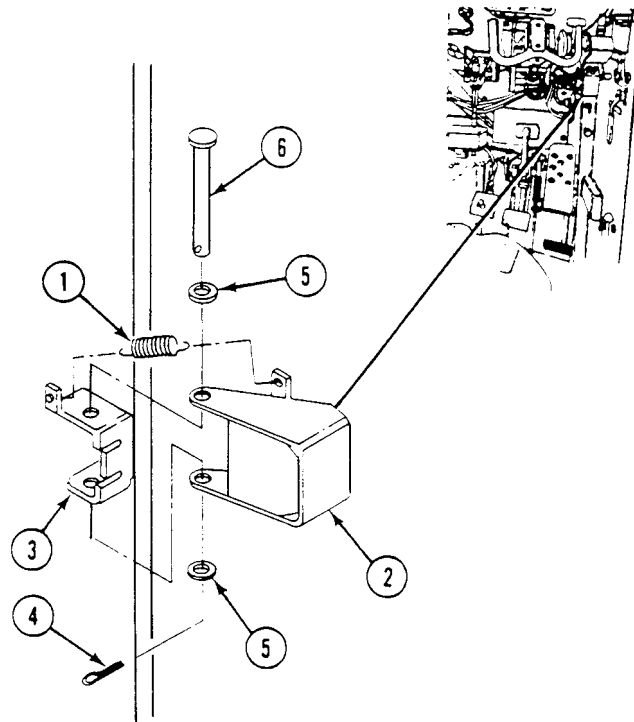

INSTALLATION

1. Install new control cover (2) on bulkhead welded bracket (3) with pin (6), two washers (5), and new cotter pin (4).
2. Install spring (1) on cover (2) and bulkhead welded bracket (3).
3. Install new marker (WP 0654 00).

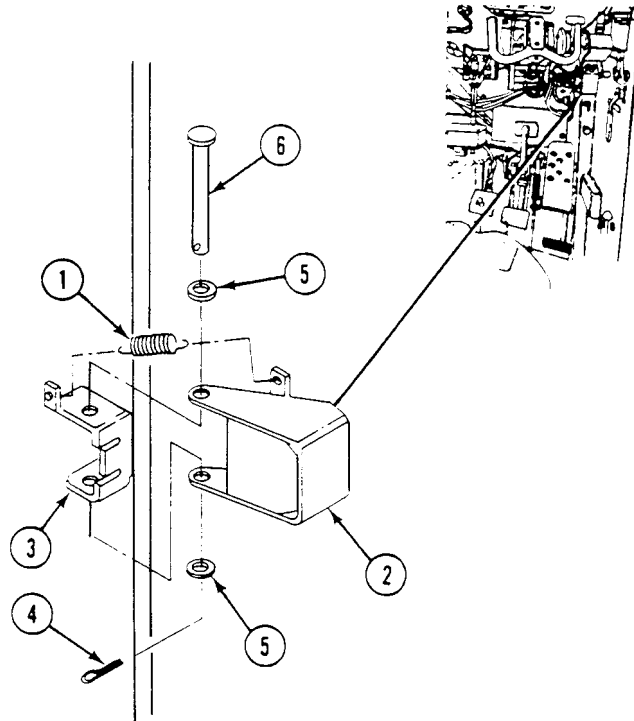
**END OF TASK**

ADJUST TRANSMISSION STEERING

0393 00

THIS WORK PACKAGE COVERS:

Check Adjustment (page 0393 00-1).
 Adjustment (page 0393 00-3).

INITIAL SETUP:

Maintenance Level
 Unit

References
 See your -10

Tools and Special Tools
 General Mechanic's Tool Kit (WP 0926 00, Item 65)
 Adjusting Sleeve (WP 0926 00, Item 7)
 Torque Wrench (WP 0926 00, Item 80)
 Torque Wrench (WP 0926 00, Item 85)

Equipment Condition
 Engine stopped (see your -10)
 Carrier blocked (see your -10)
 Driver's power plant access panel removed
 (see your -10)
 Air Intake elbow removed (WP 0173 00)
 Engine exhaust elbow removed (WP 0221 00)

Materials/Parts
 Preformed packing

Personnel Required
 Unit Mechanic
 Helper (H) (2)

ADJUSTMENT

CHECK ADJUSTMENT

WARNING

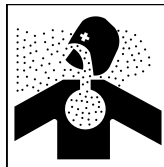

Breathing carbon monoxide fumes from engine exhaust could kill you or injure you. Perform tests outdoors or in well ventilated area.

WARNING



Clear the area before checking adjustment. Carrier may pivot steer and injure personnel. Place transmission controller in SL before checking adjustment.

NOTE

See your -10 for all operating procedures.

1. (H) Place transmission controller in SL position. Start engine and allow to reach operating temperature.

2. (H) Release parking brake and let engine run at idle.
3. Watch both tracks. Have helper assist. If there is no track tension, adjustment is correct.

WARNING



If steering wheel is turned while engine is running at 1000 rpm or greater, the carrier will pivot and personnel could be killed or equipment damaged.

4. (H) Place transmission controller in PV position.
5. (H) Turn steering wheel left and right at idle speed.
6. Watch both tracks. Have helper assist. There will be some change in track tension, but carrier will not move.
7. (H) Place transmission controller in SL position.
8. (H) With steering wheel in center position, increase engine speed to 1,000 rpm.

NOTE

If there is any change in track tension or if there is any hydrostatic noise from the transmission at any engine speed, the steering unit needs adjustment.

9. Watch both tracks. Have helper assist. There must be no change in track tension or transmission sound.

WARNING



If steering wheel is turned while engine is running at 1000 rpm or greater, the carrier will pivot and personnel could be killed or equipment damaged.

10. (H) Slowly increase engine speed to 2,800 rpm.

NOTE

If there is any change in track tension or if there is any hydrostatic noise from the transmission at any engine speed, the steering unit needs adjustment.

11. Watch both tracks. Have helper assist. There must be no change in track tension or transmission sound.

ADJUSTMENT

WARNING



Stop engine before making adjustment (see your -10).

CAUTION

Care must be taken to keep tools from falling into transmission during adjustment procedures.

1. Remove access plug (1) and preformed packing (2) from steering centering adjustment on left rear of transmission. Discard packing.

NOTE

Be careful not to turn adjusting screw when loosening jam nut.

2. Loosen jam nut (3) on adjusting screw (4). Use adjusting sleeve.

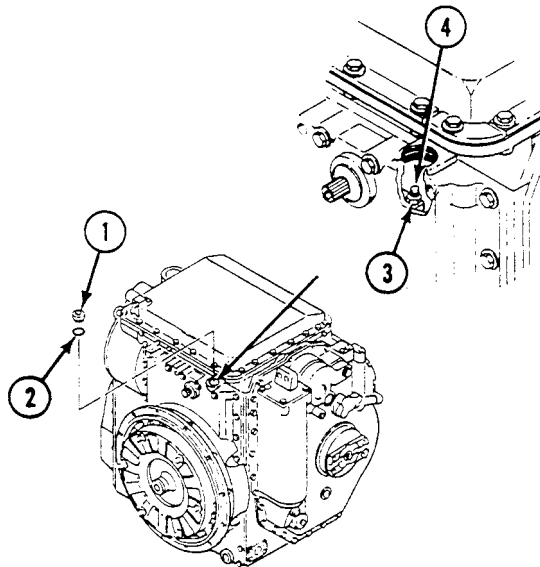

NOTE

Be careful not to turn adjusting screw when tightening jam nut.

3. Turn adjusting screw (4) 1/8 turn at a time. Use adjusting sleeve. If right track had forward tension, turn adjusting screw to the right. If left track had forward tension, turn adjusting screw to the left.
4. TIGHTEN JAM NUT (3) TO 140-150 LB-IN. (16-18 N·m) TORQUE. USE ADJUSTING SLEEVE.
5. Install plug (1) finger tight and check adjustment by repeating Steps 1 - 11.
6. Repeat Steps 1 - 3 as needed until both tracks remain slack at all engine speeds.
7. Remove plug (1), and install new preformed packing (2) in plug.
8. Install plug (1) in transmission. TIGHTEN PLUG TO 50-60 LB-FT (68-81 N·m) TORQUE.

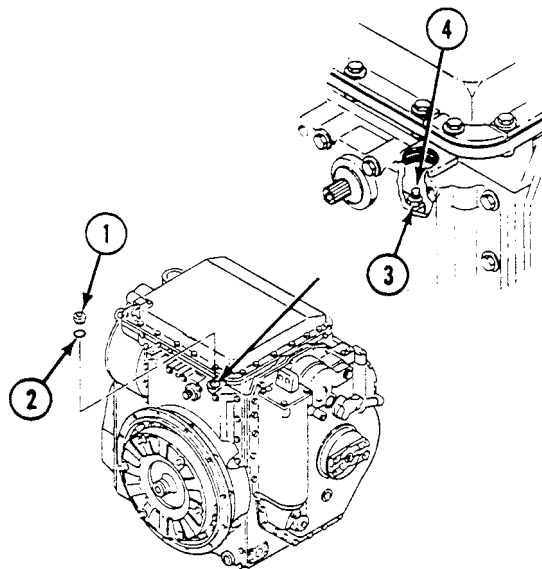
**FOLLOW-THROUGH STEPS**

1. Install engine exhaust elbow (WP 0221 00).
2. Install air intake elbow (WP 0173 00).
3. Install driver's power plant access panel (see your -10).

END OF TASK

ADJUST TRANSMISSION BRAKES

0394 00

THIS WORK PACKAGE COVERS:

- Adjust left-hand brake (page 0394 00-1).
- Adjust right-hand brake (page 0394 00-5).

INITIAL SETUP:

Maintenance Level

Unit

Personnel Required

Unit Mechanic
Helper (H) (2)

Tools and Special Tools

- General Mechanic's Tool Kit (WP 0926 00, Item 65)
- Splined socket (WP 0926 00, Item 49)
- Socket wrench set (WP 0926 00, Item 72)
- Torque wrench (WP 0926 00, Item 80)
- Torque wrench (WP 0926 00, Item 85)

References

See your -10

Materials/Parts

- Sealing compound (WP 0928 00, Item 54)
- Gasket
- Gasket
- Self-locking screw (4)
- Self-locking screw (6)

Equipment Condition

- Engine stopped (see your -10)
- Carrier blocked (see your -10)
- Trim vane lowered (see your -10)
- Power plant access door open (see your -10)
- Hull front access cover removed (WP 0449 00)

ADJUSTMENT

ADJUST LEFT-HAND BRAKE

1. Remove four self-locking screws (1), washers (2), cover (3), and gasket (4) from transmission (5). Discard gasket and screws.

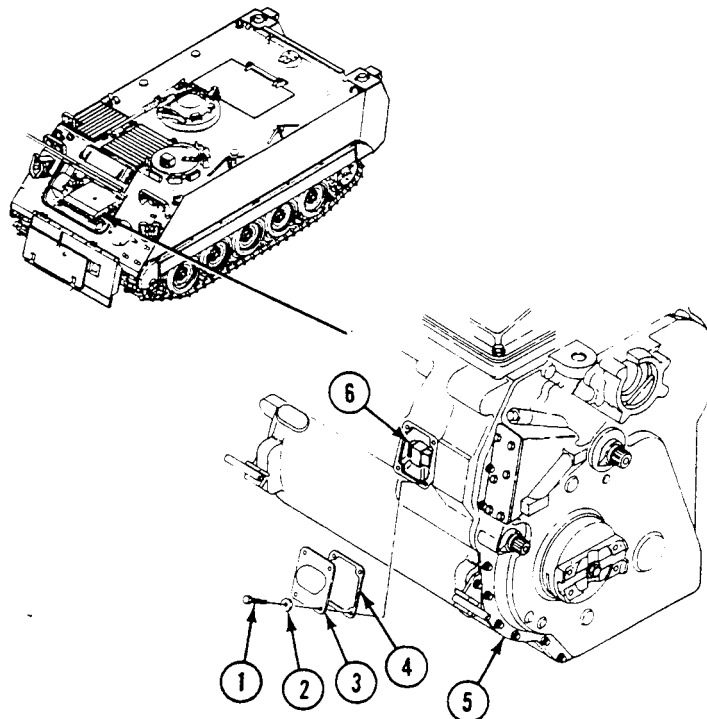

- Remove governor assembly (6), turning clockwise to disengage gear teeth.

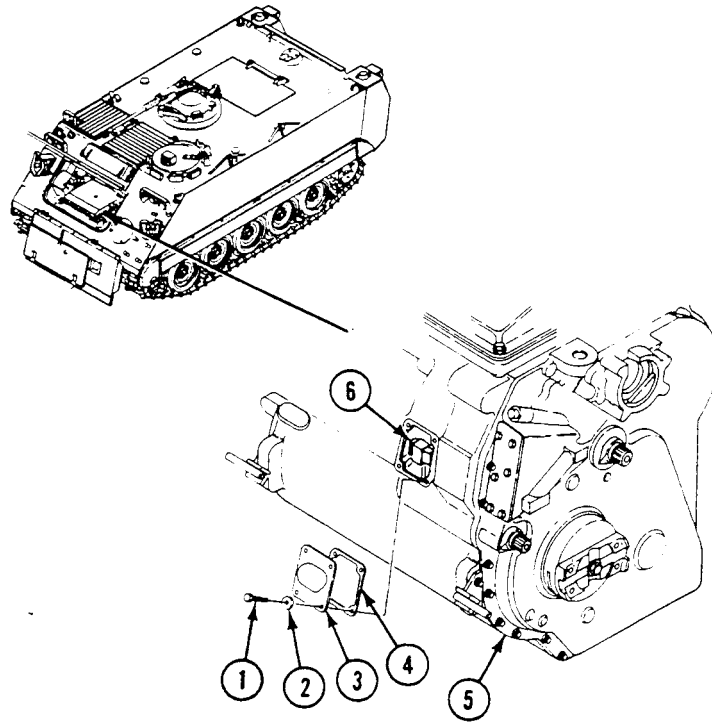

CAUTION

Do not remove screw on adjusting link spring. Removal of screw may cause damage to equipment.

- Loosen screw (7) to release spring tension on brake adjusting link (8).

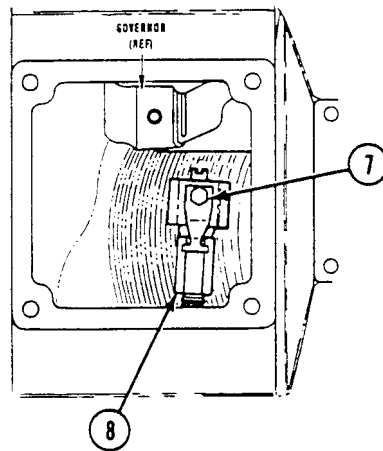

NOTE

If power plant is not in carrier or if linkage is not connected to transmission, do Step 4 to adjust left-hand brake.

If arm is not on transmission, use splined socket to apply torque to shaft.

Combination wrench turned to right (counterclockwise rotation of adjusting link) tightens brake. Combination wrench turned to left (clockwise rotation of adjusting link) loosens brake.

If indicator stopped before APPLY mark, brakes are too tight. If indicator stopped past mark, brakes need to be tightened. Brake adjusting link should be turned only 1/6 turn (60 degrees) at a time until proper brake adjustment is achieved.

4. Apply 40 lb-ft (54 N·m) torque to shaft (1) or arm (2). Turn brake adjusting link (3) with an angle-head wrench until indicator (4) lines up opposite APPLY mark (5).

NOTE

If power plant is in carrier, do Step 5 to adjust left-hand brake.

5. Apply 104 lb-ft (141 N·m) torque to brake shaft nut (6). Turn brake adjusting link (3) with an angle-head wrench until indicator (4) lines up opposite APPLY mark (5).

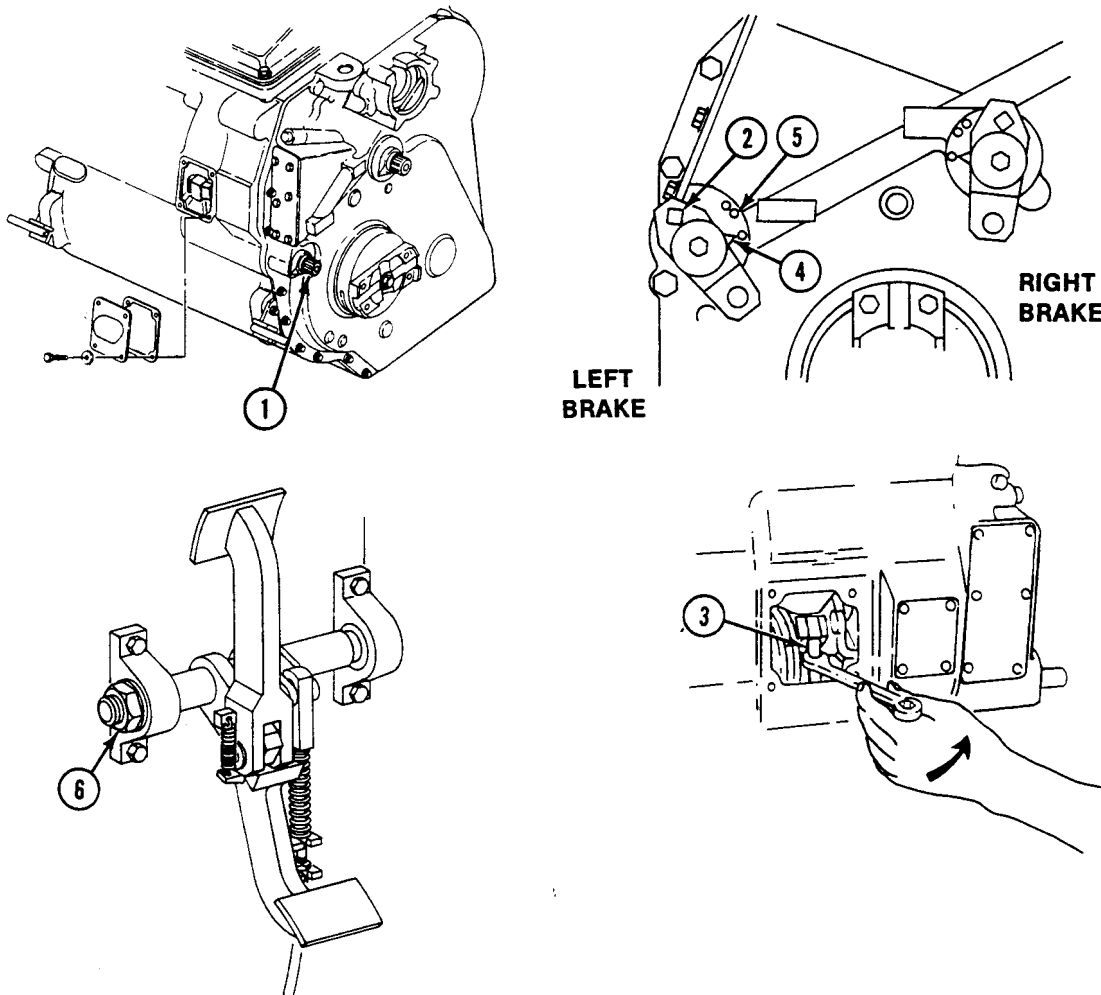

ADJUST TRANSMISSION BRAKES — Continued

0394 00

6. Repeat Step 4 or Step 5 as needed until indicator (4) stops at APPLY mark (5) at specified torque.
7. Tighten screw (1) on adjusting link spring (2).
8. Install governor assembly (3), engaging gear counterclockwise.
9. Install new gasket (4) and cover (5) on transmission (6). Secure with four washers (7) and new self-locking bolts (8).
TIGHTEN BOLTS TO 204-240 LB-IN (23-27 N·m) TORQUE.

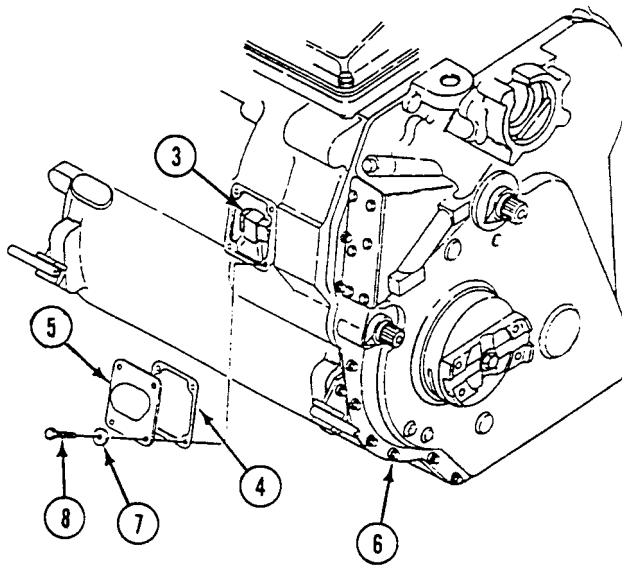
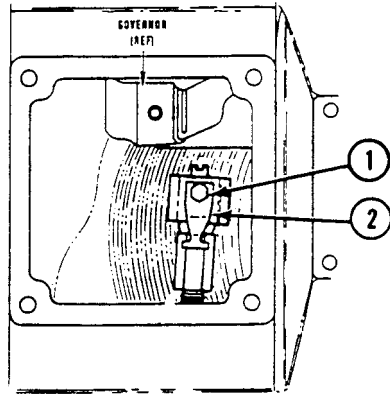

ADJUST RIGHT-HAND BRAKE

1. Disconnect oil return hose (9) from elbow (10) on transmission end cover (11). Plug hose.
2. Remove six self-locking bolts (12), washers (13), cover (11), and gasket (14) from transmission (6). Discard gasket and bolts.

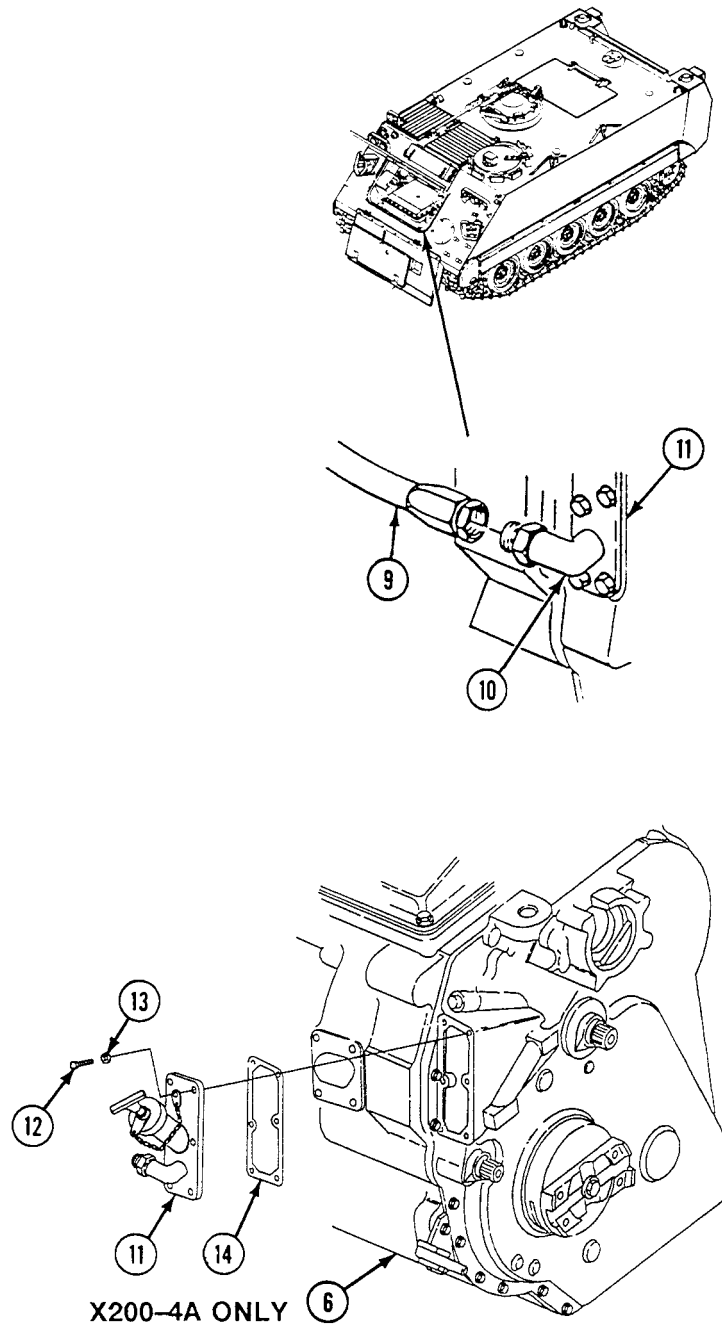

NOTE

If indicator stopped before APPLY mark, brakes are too tight. If indicator stopped past mark, brakes need to be tightened. Brake adjusting link should be turned only 1/6 turn (60 degrees) at a time until proper brake adjustment is achieved.

3. Turn brake adjustment screw (1) inside transmission to adjust brakes. If indicator passed APPLY mark, turn to the left and tighten. If indicator did not reach APPLY mark, turn to the right and loosen.

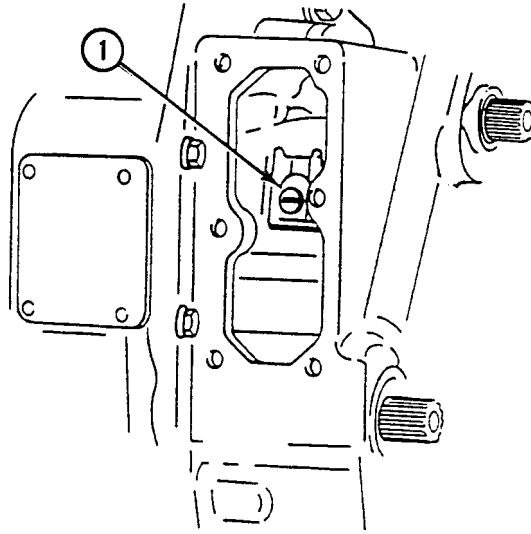

4. Check transmission brake adjustment (WP 0406 00).
5. Repeat Step 3 and Step 4 as needed until indicator stops at APPLY mark at specified torque.

6. Install new gasket (2) and cover (3) on transmission (4). Secure with six washers (5) and self-locking bolts (6).
TIGHTEN BOLTS (3) TO 156-180 LB-IN. (18-20 N.m) TORQUE.
7. Connect hose (7) to elbow (8).

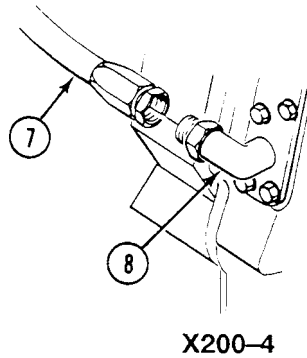
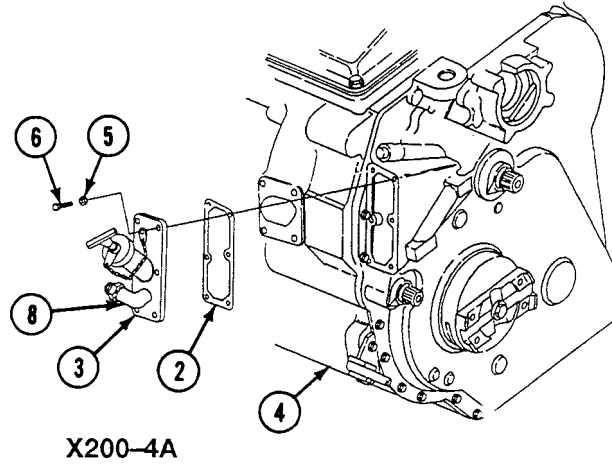

FOLLOW-THROUGH STEPS

1. Install power plant (if removed) (WP 0156 00).
2. Close power plant door (see your -10).
3. Install hull front access cover panel (WP 0449 00).
4. Raise and lock trim vane (see your -10).

END OF TASK

REPLACE TRANSMISSION OIL LEVEL DIPSTICK, FILLER TUBE, AND ADAPTER (X200-4 ONLY)

0395 00

THIS WORK PACKAGE COVERS:

Removal (page 0395 00-1).
 Installation (page 0395 00-3).

INITIAL SETUP:

Maintenance Level

Unit

Personnel Required

Unit Mechanic

Tools and Special Tools

General Mechanic's Tool Kit (WP 0926 00, Item 65)
 Socket Wrench Attachment (WP 0926 00, Item 52)
 Torque Wrench (WP 0926 00, Item 81)

References

See your -10

Materials/Parts

Gasket
 Lockwasher
 Preformed packing

Equipment Condition

Engine stopped (see your -10)
 Carrier blocked (see your -10)
 Power plant removed (WP 0156 00)
 Transmission oil drained (WP 0398 00)

REMOVAL

NOTE

Transmission must be drained before starting task.

1. Loosen screw (1) on clamp (2). Do not remove screw.
2. Remove coupling nut (3) and filler tube (4) from elbow (5).

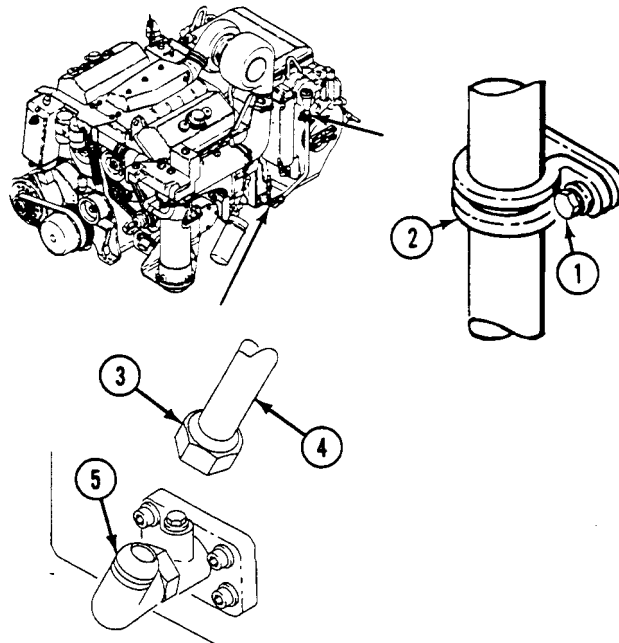

**REPLACE TRANSMISSION OIL LEVEL DIPSTICK, FILLER TUBE, AND ADAPTER
(X200-4 ONLY) — Continued**

0395 00

3. Remove screw (1), washer (6), lockwasher (7), clamp (2), and filler tube (4) from engine compartment. Discard lockwasher. Remove dipstick (8) from tube.

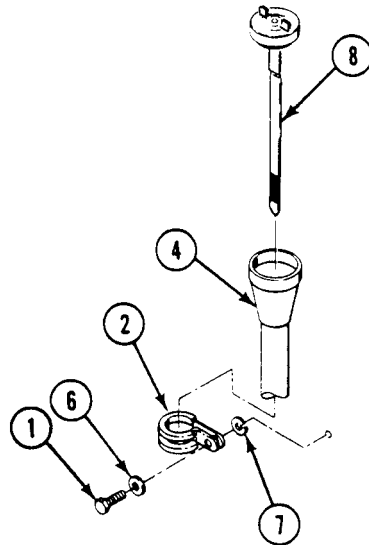

4. Remove plug (1) from transmission adapter (2).
5. Remove four screws (3), adapter (2), and gasket (4) from transmission (5). Discard gasket.
6. Loosen jam nut (6) on elbow (7). Remove elbow and preformed packing (8) from adapter (2). Discard preformed packing.

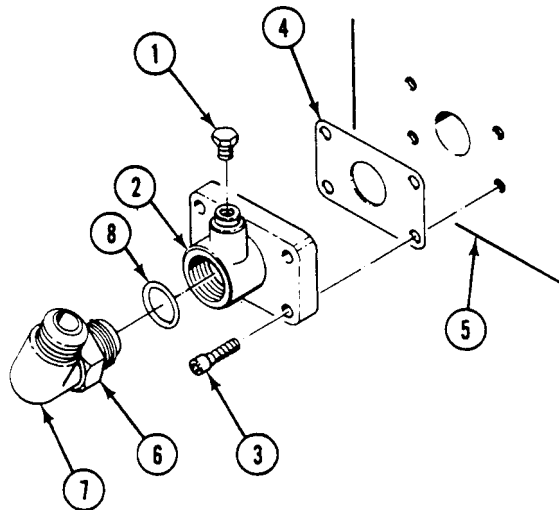

**REPLACE TRANSMISSION OIL LEVEL DIPSTICK, FILLER TUBE, AND ADAPTER
(X200-4 ONLY) — Continued**

0395 00

INSTALLATION

1. Install new preformed packing (8) on elbow (7). Install elbow on adapter (2) and thread jam nut (6). Do not tighten jam nut.
2. Install new gasket (4) and adapter (2) on transmission (5). Secure with four screws (3). **TIGHTEN SCREWS TO 20-25 LB-FT (27-34 N·m) TORQUE.**
3. Install plug (1) on adapter (2).

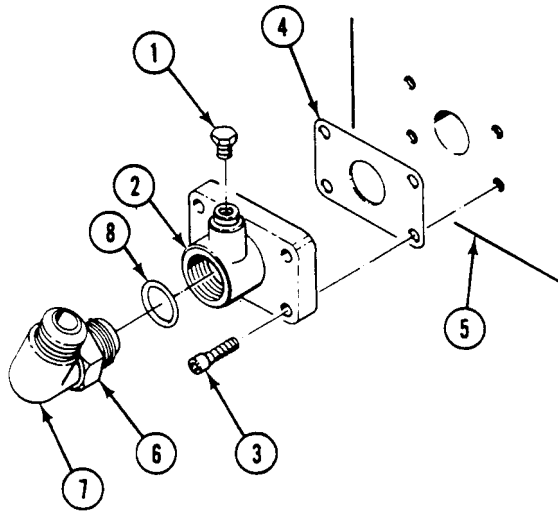

**REPLACE TRANSMISSION OIL LEVEL DIPSTICK, FILLER TUBE, AND ADAPTER
(X200-4 ONLY) — Continued**

0395 00

- Slide clamp (9) on filler tube (10). Position tube on elbow (7) and thread coupling nut (11). Do not tighten nut. Secure clamp to transmission (5) with washer (12), new lockwasher (13), and screw (14).
- Tighten jam nut (6). Tighten coupling nut (11).
- Install dipstick (15) in filler tube (10).

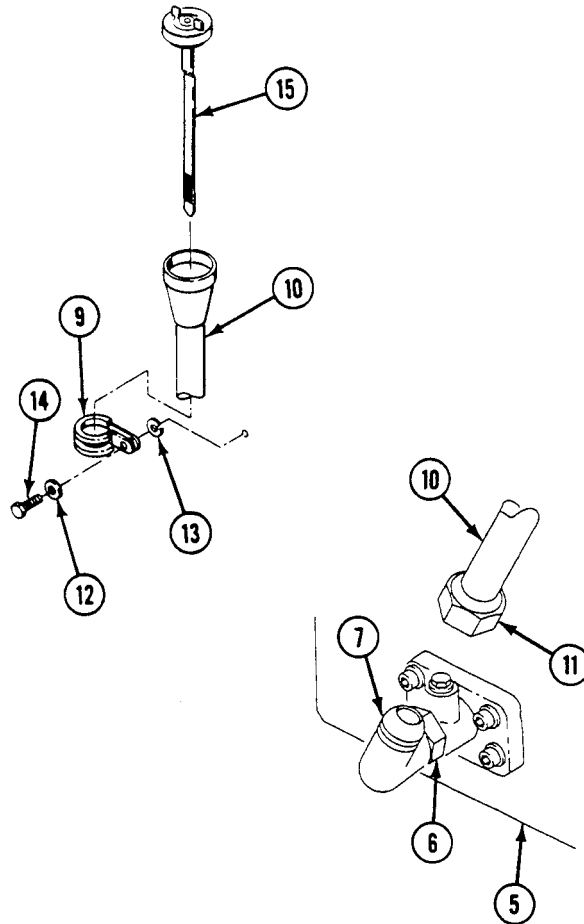
**FOLLOW-THROUGH STEPS**

- Fill transmission with oil (WP 0398 00).
- Install power plant (WP 0156 00).

END OF TASK

**REPLACE TRANSMISSION OIL LEVEL DIPSTICK, FILLER TUBE, AND
ADAPTER (X200-4A ONLY)**

0396 00

THIS WORK PACKAGE COVERS:

Removal (page 0396 00-1).
Installation (page 0396 00-4).

INITIAL SETUP:

Maintenance Level

Unit

Personnel Required

Unit Mechanic

Tools and Special Tools

General Mechanic's Tool Kit (WP 0926 00, Item 65)
Socket Wrench Attachment (WP 0926 00, Item 52)
Torque Wrench (WP 0926 00, Item 81)

References

See your -10

Materials/Parts

Gasket
Lockwasher
Preformed packing

Equipment Condition

Engine stopped (see your -10)
Carrier blocked (see your -10)
Power plant removed (WP 0156 00)
Transmission oil drained (WP 0398 00)

REMOVAL

NOTE

Transmission must be drained before starting task.

1. Remove screw (1), washer (2), clamp (3), and nut (4) from bracket (5). Remove clamp from tube (6).

**REPLACE TRANSMISSION OIL LEVEL DIPSTICK, FILLER TUBE, AND ADAPTER
(X200-4A ONLY) — Continued**

0396 00

- Loosen coupling nut (7) and remove tube (6) from elbow (8). Remove dipstick (9) from tube.

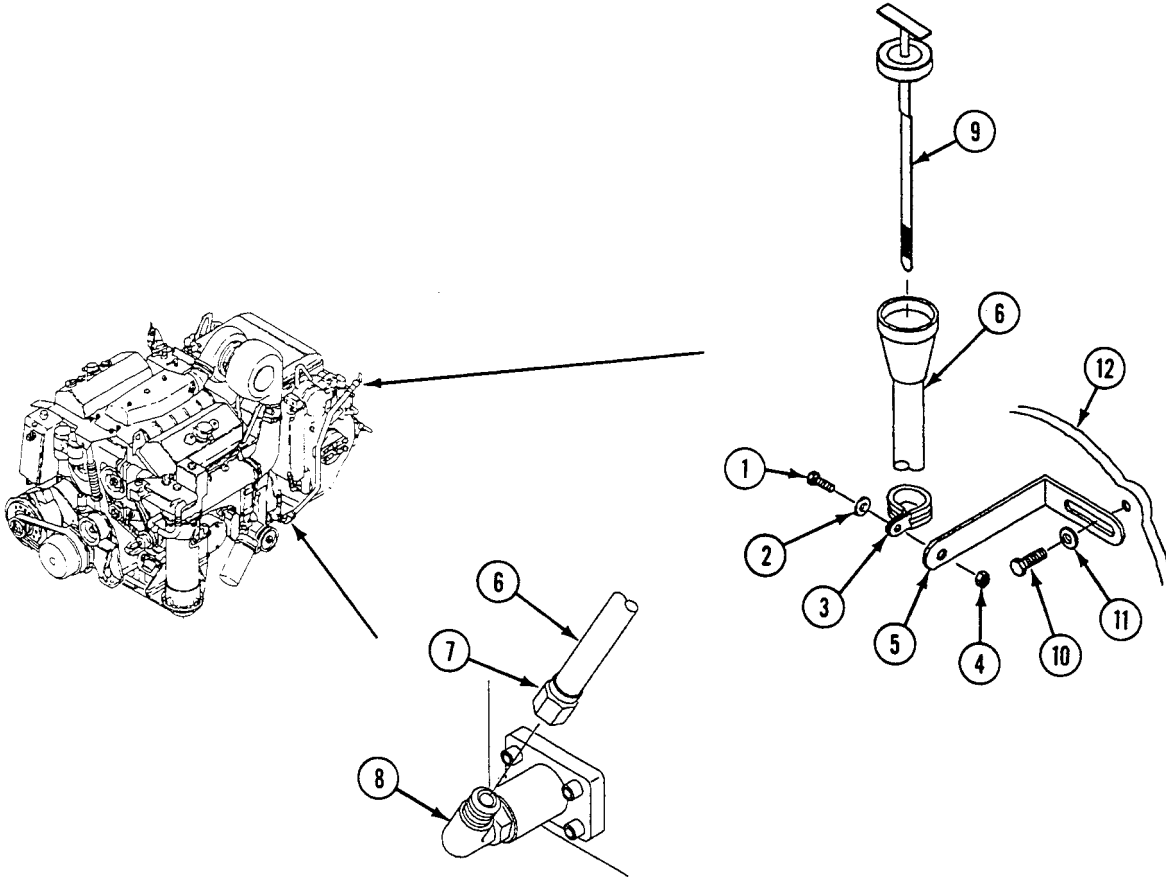

**REPLACE TRANSMISSION OIL LEVEL DIPSTICK, FILLER TUBE, AND ADAPTER
(X200-4A ONLY) — Continued**

0396 00

3. Remove screw (10), washer (11), and bracket (5) from transmission end cover (12).

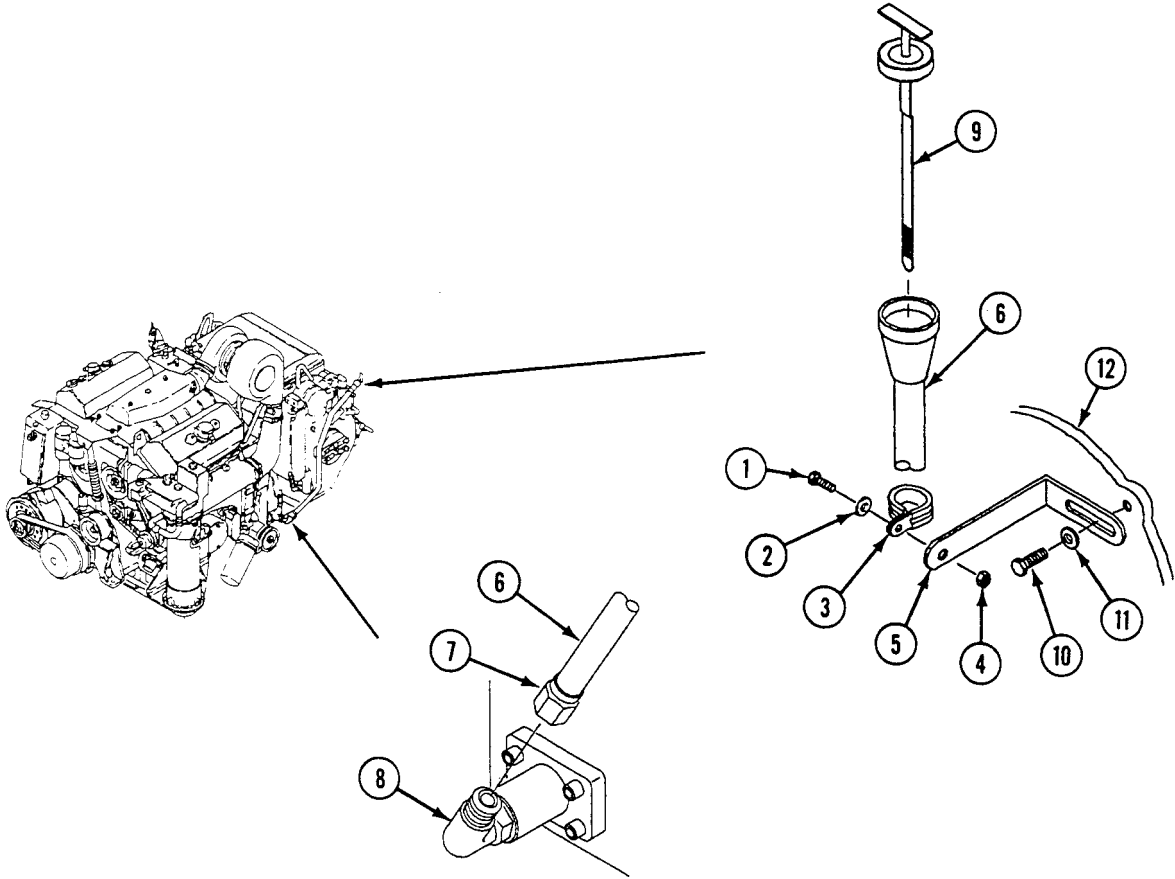

4. Loosen jam nut (1) on elbow (2). Remove elbow and preformed packing (3) from adapter (4). Discard preformed packing.
5. Remove four screws (5), adapter (4), and gasket (6) from transmission (7). Discard gasket.

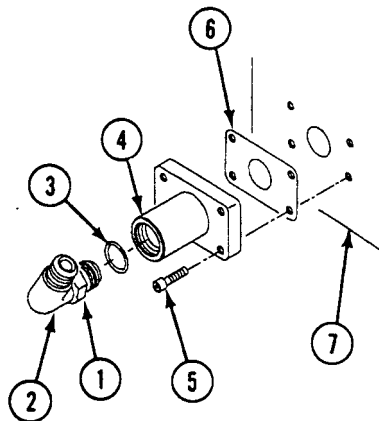

**REPLACE TRANSMISSION OIL LEVEL DIPSTICK, FILLER TUBE, AND ADAPTER
(X200-4A ONLY) — Continued**

0396 00

INSTALLATION

1. Install new gasket (6) and adapter (4) on transmission (7). Secure with four screws (5). **TIGHTEN SCREWS TO 20-25 LB-FT (27-34 N·m) TORQUE.**
2. Install new preformed packing (3) and elbow (2) on adapter (4) and thread jam nut (1). Do not tighten nut.

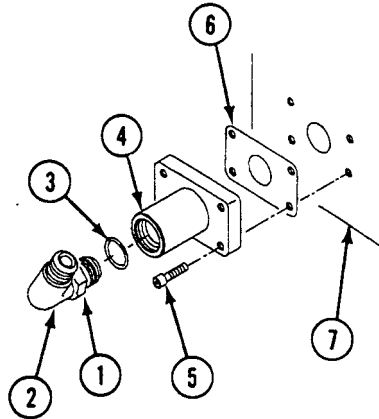

3. Slide clamp (8) on tube (9). Position tube on elbow (2) and thread coupling nut (10). Do not tighten nut.
4. Install bracket (11) on transmission cover (12). Secure with washer (13) and screw (14).
5. Align clamp (8) with bracket (11). Secure clamp with screw (15) washer (16), and nut (17).
6. Tighten jam nut (1) and coupling nut (10).

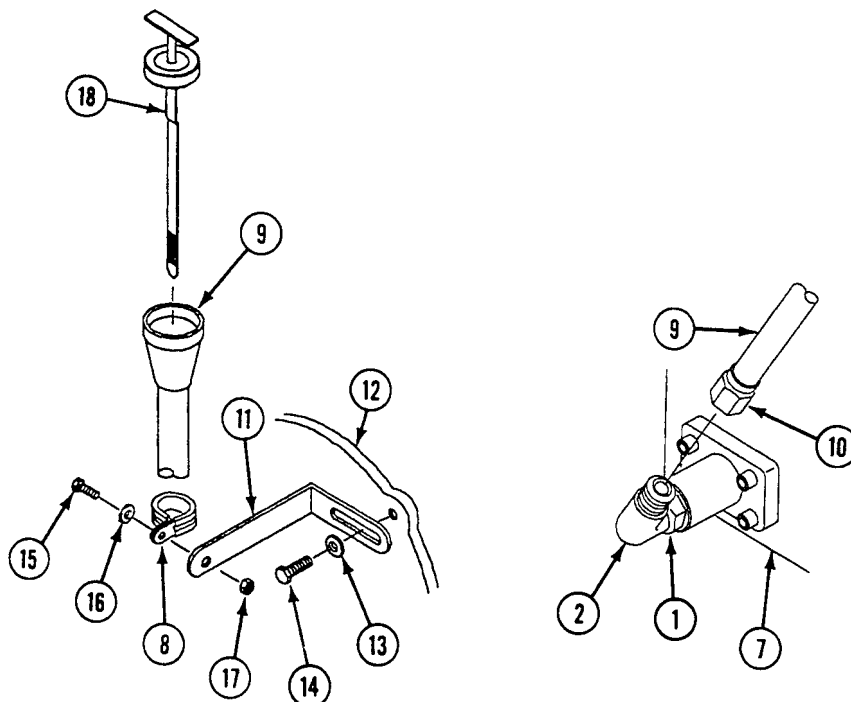

REPLACE TRANSMISSION OIL LEVEL DIPSTICK, FILLER TUBE, AND ADAPTER
(X200-4A ONLY) — Continued

0396 00

7. Install dipstick (18) in tube (9).

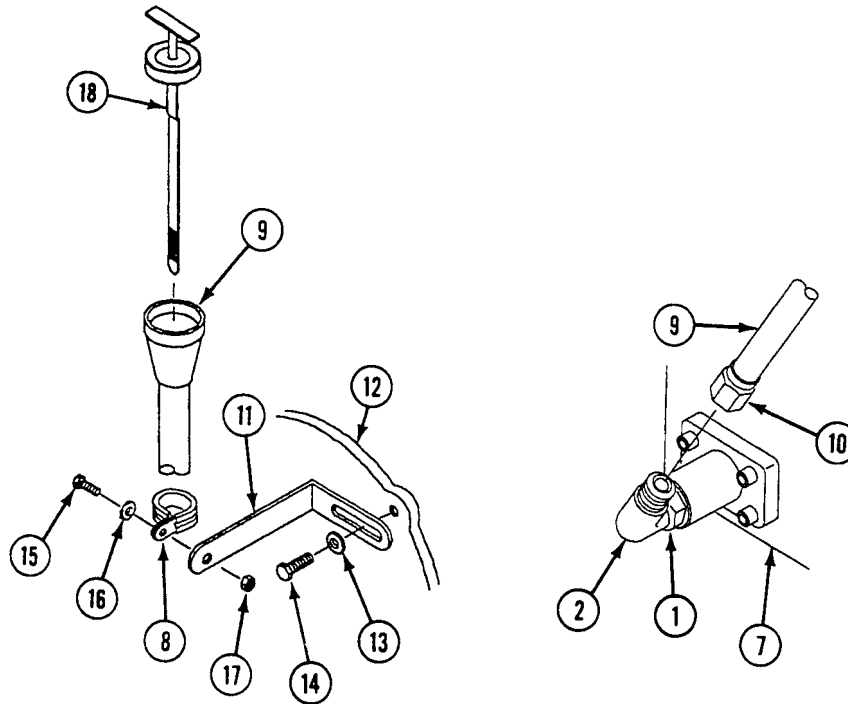
**FOLLOW-THROUGH STEPS**

1. Fill transmission with oil (WP 0398 00).
2. Install power plant (WP 0156 00).
3. Unblock carrier (see your -10)
4. Start engine (see your -10)

END OF TASK

REPLACE GOVERNOR ASSEMBLY

0397 00

THIS WORK PACKAGE COVERS:

Removal (page 0397 00-1).
 Installation (page 0397 00-3).

INITIAL SETUP:

Maintenance Level

Unit

References

See your -10

Tools and Special Tools

General Mechanic's Tool Kit (WP 0926 00, Item 65)
 Torque Wrench (WP 0926 00, Item 82)

Equipment Condition

Engine stopped (see your -10)
 Carrier blocked (see your -10)
 Power plant door opened (see your -10)
 Trim vane lowered (see your -10)
 Power plant removed (WP 0156 00)

Materials/Parts

Gasket
 Self-locking bolt (4)

Personnel Required

Unit Mechanic

REMOVAL

1. Remove four self-locking bolts (1) and washers (2) from brake adjustment cover (3). Remove cover and gasket (4) from rear of transmission. Discard gasket and bolts.

2. Remove governor assembly (5) from transmission. No repair is authorized. Replace a defective governor.

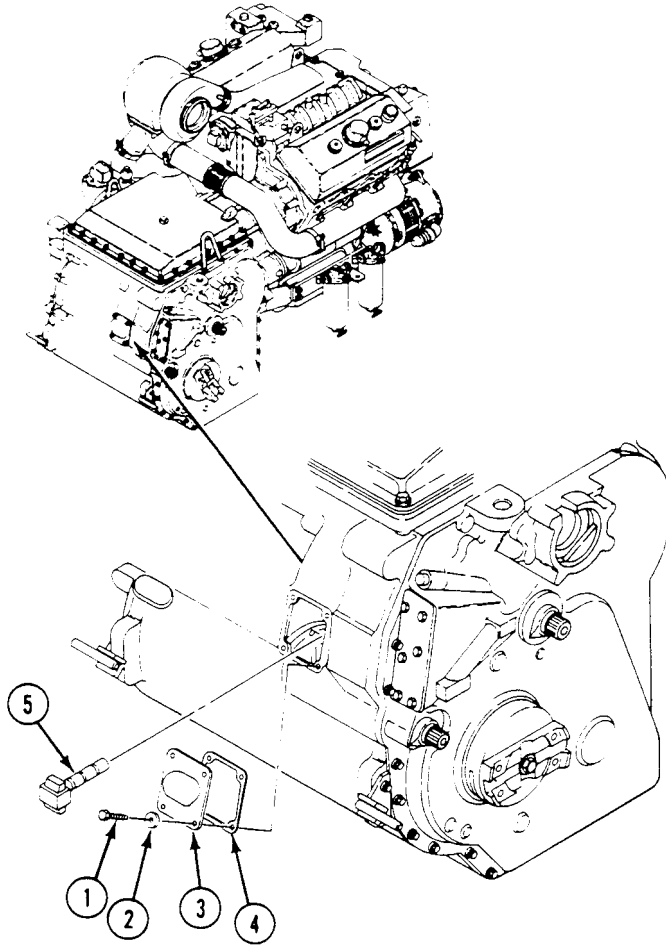

INSTALLATION

1. Install new governor assembly (5) in transmission. Twist governor slightly to the right while inserting it into bore inside transmission.
2. Install cover (3) and new gasket (4) on transmission. Secure with four washers (2) and new self-locking bolts (1).
TIGHTEN BOLTS TO 13-15 LB-FT (18-20 N·m) TORQUE.

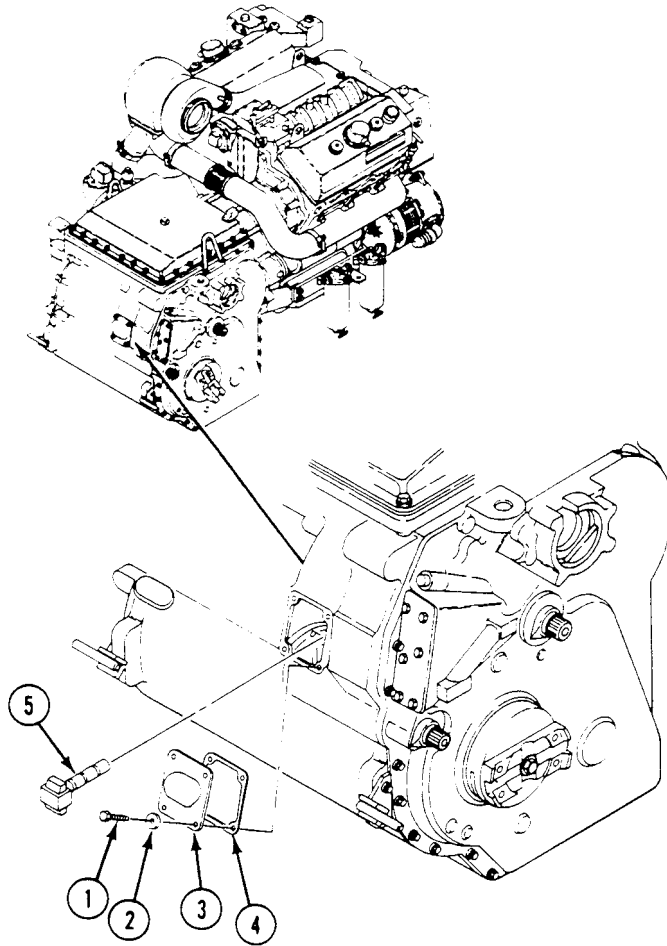
**FOLLOW-THROUGH STEPS**

1. Install power plant (WP 0156 00).
2. Close power plant door (see your -10).
3. Raise trim vane (see your -10).

END OF TASK

REPLACE TRANSMISSION OIL AND OIL FILTER ELEMENT

0398 00

THIS WORK PACKAGE COVERS:

- Removal (page 0398 00-1).
- Installation (page 0398 00-3).

INITIAL SETUP:

Maintenance Level

Unit

Personnel Required

Unit Mechanic

Tools and Special Tools

- General Mechanic's Tool Kit (WP 0926 00, Item 65)
- Torque Wrench (WP 0926 00, Item 85)

References

- See your -10
- See WP 0155 00

Materials/Parts

- Automotive grease (WP 0928 00, Item 12)
- Transmission oil (WP 0928 00, Item 28)
- Container (12 gallons)
- Preformed packing (2)
- Transmission parts kit
- Screw (3)

Equipment Condition

- Engine stopped (see your -10)
- Carrier blocked (see your -10)
- Trim vane lowered (see your -10)
- Power plant access door opened (see your -10)
- Power plant bottom access cover removed (WP 0450 00)
- Air intake elbow removed (WP 0173 00)

REMOVAL

1. Place container under hull bottom access hole.
2. Remove plug (1) from drain tube (2). Drain transmission oil into container. Discard oil in accordance with Army regulations.

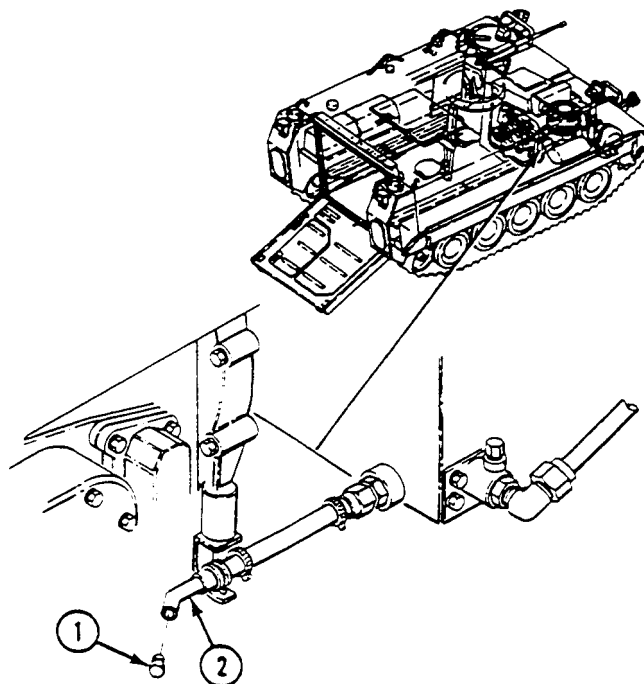

NOTE

Oil filter element MUST be replaced when transmission oil is drained.

3. Disconnect lead (1) from filter head (2).
4. Remove three screws (3), washers (4), and filter head (2) from filter body (5). Use two screws as jack screws (6). Discard three screws.
5. Remove filter element (7) and two preformed packings (8) from filter body (5). Discard packings. Discard filter element in accordance with Army regulations.
6. Remove oil from filter body (5).

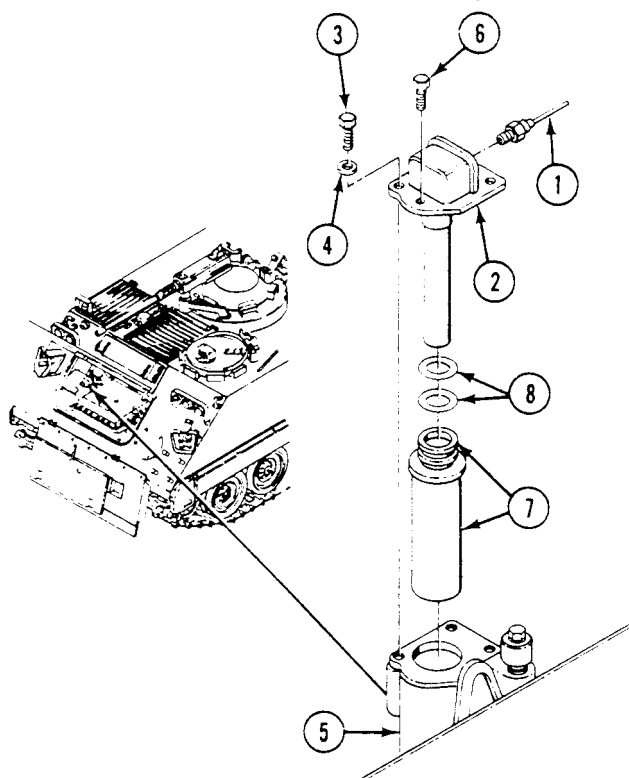

INSTALLATION

1. Lubricate two new packings (8) with grease (WP 0155 00).
2. Install new preformed packing on new element (7). Install element in filter body (5).
3. Install two new preformed packings (8) on filter head (2). Install filter head on filter body (5). Secure with three new screws (3) and washers (4). Tighten screws to 23-25 lb-ft (30-34 N.m) torque.
4. Connect lead (1) to filter head (2).

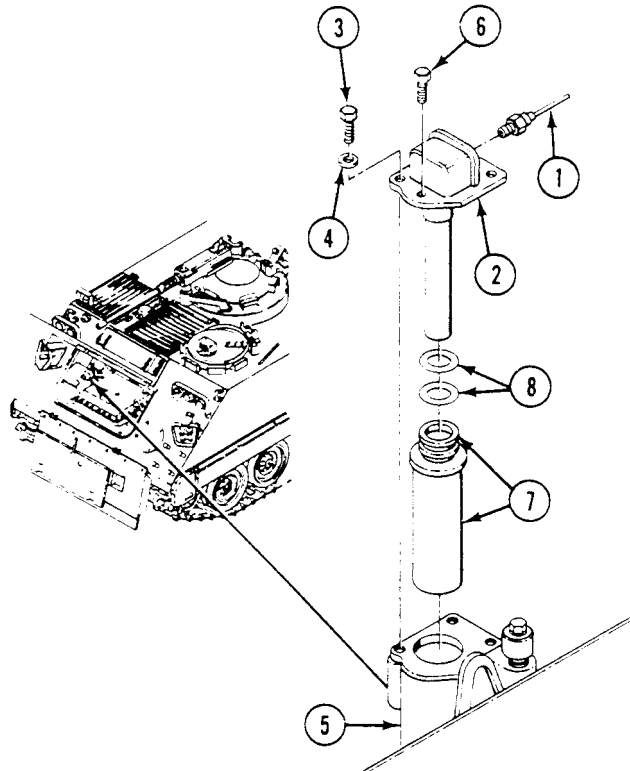

5. Install plug (9) on drain tube (10).

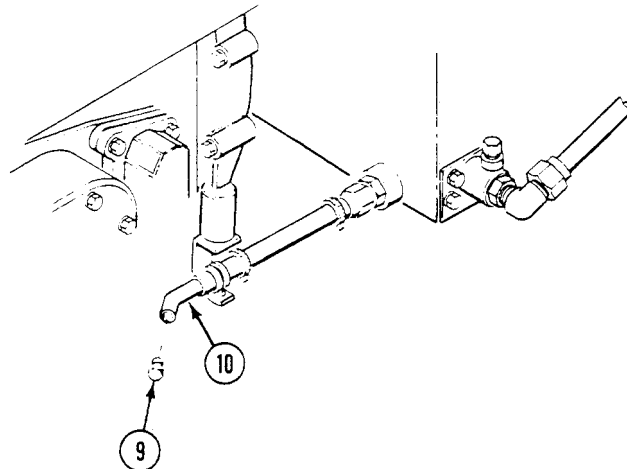

NOTE

Transmission must be serviced with operational lubricant in accordance with transmission tag on filler neck and your (WP 0155 00).

6. Fill transmission with oil to bring level between ADD and FULL mark on dipstick (1). See transmission tag on filler neck and (WP 0155 00).
7. Install air intake elbow (WP 0173 00).
8. Turn MASTER SWITCH ON (see your -10).
9. Run engine for 3 to 5 minutes (see your -10). Check fluid level (WP 0155 00). Transmission oil level should be between ADD and FULL on dipstick (1). Check for leaks.

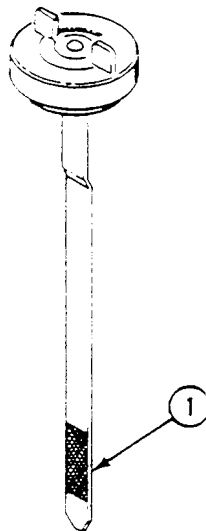
**FOLLOW-THROUGH STEPS**

1. Stop engine (see your -10).
2. Install power plant bottom access cover (WP 0450 00).
3. Close power plant access door (see your -10).
4. Raise trim vane (see your -10).

END OF TASK

REPLACE TRANSMISSION OIL COOLER HOSES, FITTINGS, AND MOUNTING

0399 00

THIS WORK PACKAGE COVERS:

Removal (page 0399 00-1).
 Installation (page 0399 00-8).

INITIAL SETUP:

Maintenance Level

Unit

Lockscrew (2)

Packing

Packing

Strap (2)

Tools and Special Tools

General Mechanic's Tool Kit (WP 0926 00, Item 65)
 Crowfoot Attachment, Socket (WP 0926 00, Item 14)
 Socket wrench set (WP 0926 00, Item 72)
 Torque wrench (WP 0926 00, Item 80)
 Torque wrench (WP 0926 00, Item 85)

Personnel Required

Unit Mechanic

Materials/Parts

Sealing compound (WP 0928 00, Item 56)
 Petrolatum (WP 0928 00, Item 61)
 Wiping rag (WP 0928 00, Item 65)
 Gasket
 Locknut
 Lockscrew (4)
 Lockscrew (9)
 Lockscrew (15)

References

See your -10

Equipment Condition

Engine stopped (see your -10)
 Carrier blocked (see your -10)
 Power plant removed (WP 0156 00)
 Transmission oil drained (WP 0398 00)

REMOVAL

1. Remove two straps (1) from wiring harness (2) and transmission oil inlet tube (3). Discard straps.
2. Remove screw (4), two washers (5), locknut (6), and clamp (7) securing transmission oil inlet hose (8) to bracket (9). Discard locknut.
3. Remove transmission oil inlet tube (3) from nipple (10).
4. Remove transmission oil inlet tube (3) from elbow (11).

REPLACE TRANSMISSION OIL COOLER HOSES, FITTINGS, AND MOUNTING —
Continued

0399 00

5. Remove nipple (10) from transmission oil inlet hose (8).

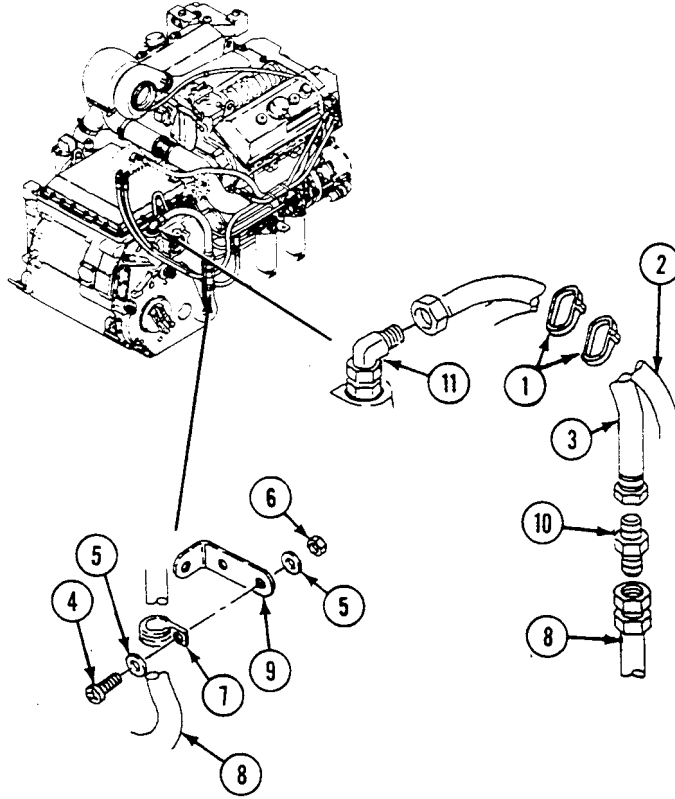

REPLACE TRANSMISSION OIL COOLER HOSES, FITTINGS, AND MOUNTING —
Continued

0399 00

NOTE**Do Steps 6 - 12 only if elbow needs to be replaced.**

6. Remove breather (1) and reducer (2) from top of transmission housing (3).
7. Remove two lockscrews (4), washers (5), and lifting bracket (6) from left end cover (7). Discard lockscrews.
8. Remove two lockscrews (8), washers (9), and lifting bracket (10) from right end cover (11). Discard lockscrews.

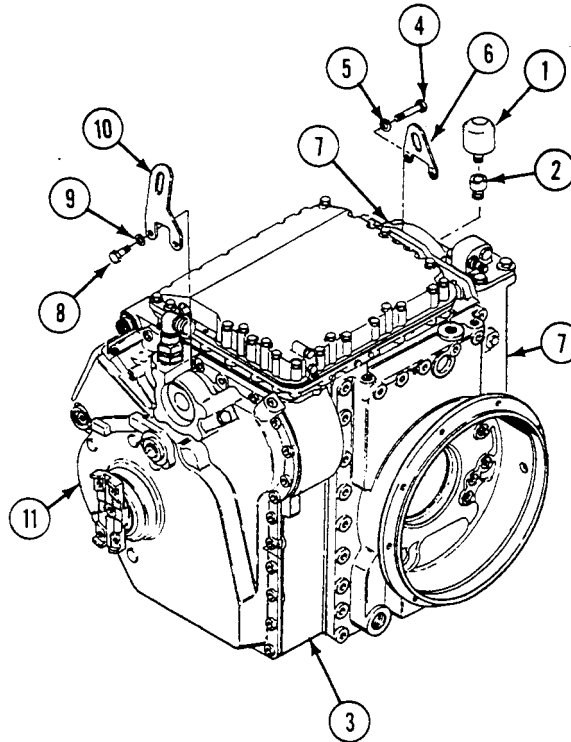
**CAUTION**

Contamination of control valves can cause transmission failure. Make sure dirt does not get into control valves when top cover is removed.

NOTE

Three different length lockscrews are used to secure top cover. Mark location of top cover lockscrews to ensure proper installation.

REPLACE TRANSMISSION OIL COOLER HOSES, FITTINGS, AND MOUNTING —
Continued

0399 00

9. Remove nine lockscrews (12), two lockscrews (13), 15 lockscrews (14), cover (15), and gasket (16) from transmission housing (3). Discard lockscrews and gasket.

NOTE

Mark direction that elbow is pointing to ensure proper alignment during installation.

NOTE

Do Step 10 and Step 11 only for transmissions equipped with an adapter for elbow.

10. Remove elbow (17) from adapter (18).
11. Remove adapter (18) and packing (19) from right end cover (11). Discard packing.

NOTE

Do Step 12 only for transmissions without an elbow adapter.

12. Loosen locknut (20) and remove elbow (17) and packing (19) from right end cover (11). Discard packing.

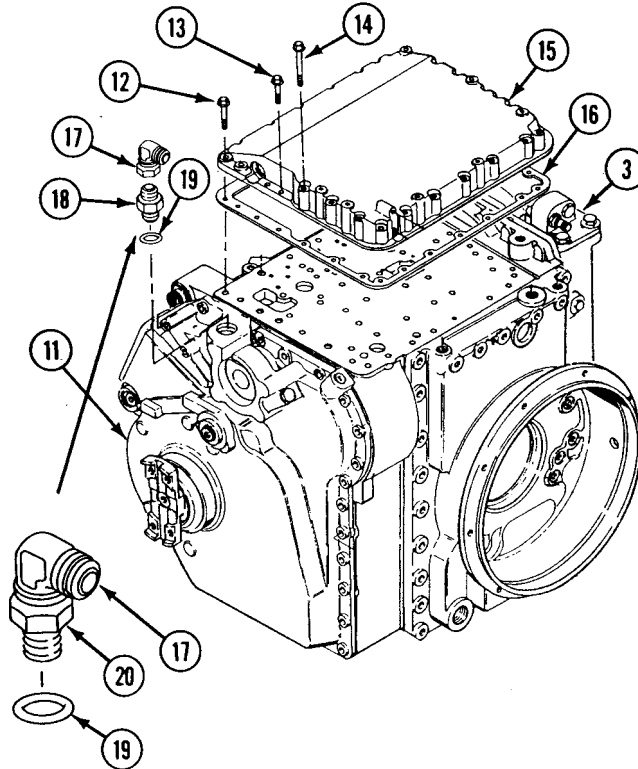

REPLACE TRANSMISSION OIL COOLER HOSES, FITTINGS, AND MOUNTING —
Continued

0399 00

13. Remove hose (1) from elbow (2) on oil cooler outlet port (3).
14. Remove elbow (2) from elbow (4) on oil cooler outlet port (3).
15. Loosen jam nut (5) and remove elbow (4) and preformed packing (6) from oil cooler outlet port (3). Discard packing.
16. Remove hose (1) from bracket (7).

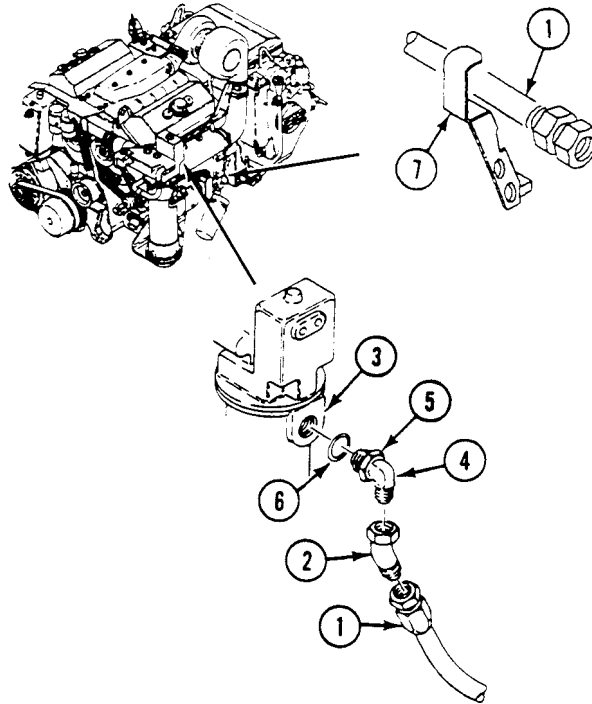

REPLACE TRANSMISSION OIL COOLER HOSES, FITTINGS, AND MOUNTING —
Continued

0399 00

17. Remove hose (8) from elbow (9) on transmission outlet port. Remove elbow and preformed packing (10) from transmission outlet port.

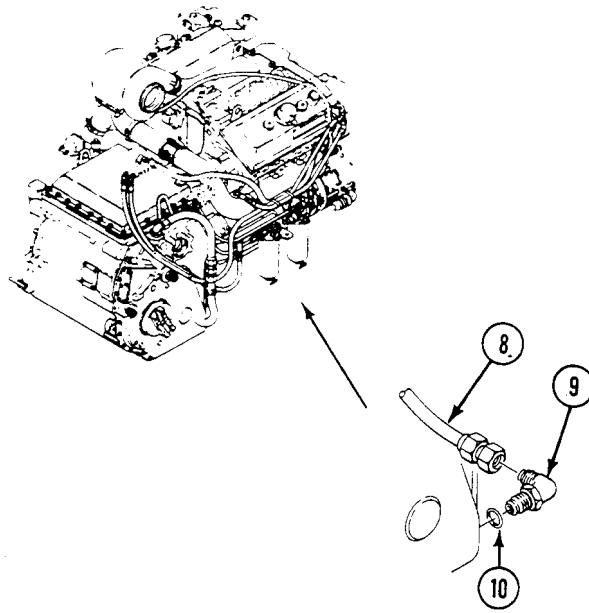

REPLACE TRANSMISSION OIL COOLER HOSES, FITTINGS, AND MOUNTING —
Continued

0399 00

18. Remove hose (8) from elbow (11) on oil cooler inlet port (12).
19. Remove hose (8) from bracket (13).

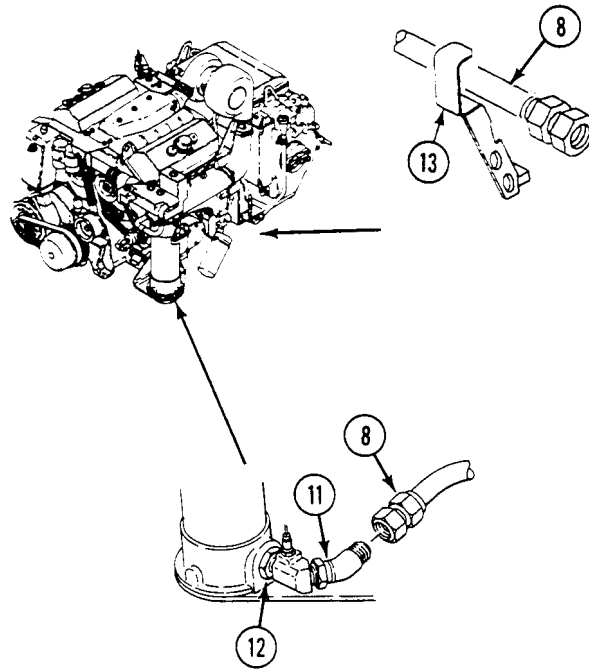

20. Remove elbow (1) from tee (2).
21. Disconnect circuit 327 lead (3) from transmission oil high temperature switch (4).
22. Remove transmission oil high temperature switch (4) from tee (2).
23. Loosen jam nut (5) and remove tee (2), retainer (6), and preformed packing (7) from oil cooler inlet port (8). Discard packing.

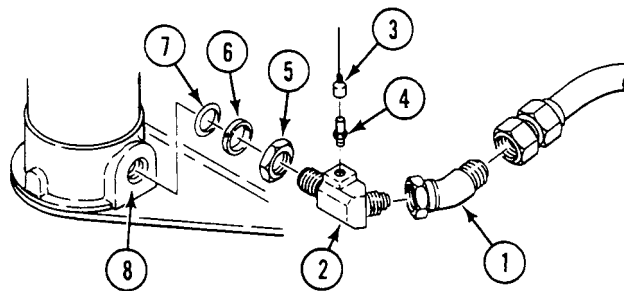

**REPLACE TRANSMISSION OIL COOLER HOSES, FITTINGS, AND MOUNTING —
Continued**

0399 00

INSTALLATION

1. Apply light coat of sealing compound to clean external tapered threads. Do not apply sealant beyond small tapered threads.
2. Install jam nut (5) on tee (2).
3. Install new preformed packing (7), retainer (6), and tee (2) on oil cooler inlet port (8). Tighten jam nut (5).
4. Install transmission oil high temperature switch (4) on tee (2).
5. Connect circuit 327 lead (3) to transmission oil high temperature switch (4).
6. Install elbow (1) on tee (2).

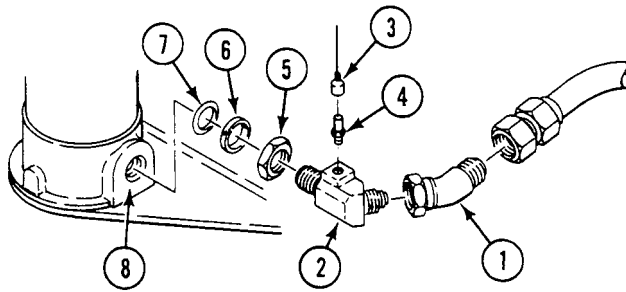

7. Route hose (9) through bracket (10) to outlet port on transmission. Install new preformed packing (11) and elbow (12) in outlet port on transmission. Install hose on elbow.

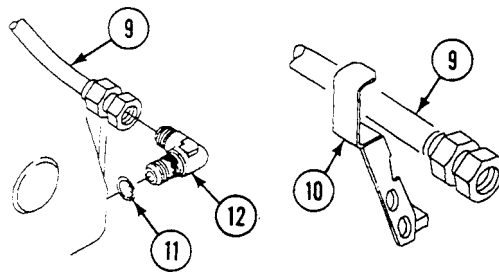

8. Install hose (9) on elbow (1) on oil cooler inlet port (8).

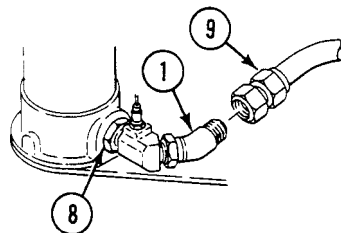

REPLACE TRANSMISSION OIL COOLER HOSES, FITTINGS, AND MOUNTING —
Continued

0399 00

9. Install new preformed packing (1) and elbow (2) on oil cooler outlet port (3). Tighten jam nut (4).
10. Install elbow (5) on elbow (2).
11. Install hose (6) on elbow (5).
12. Route hose (6) through bracket (7).
13. Install nipple (8) on transmission oil inlet hose (6).
14. Install transmission oil inlet tube (9) on nipple (8).

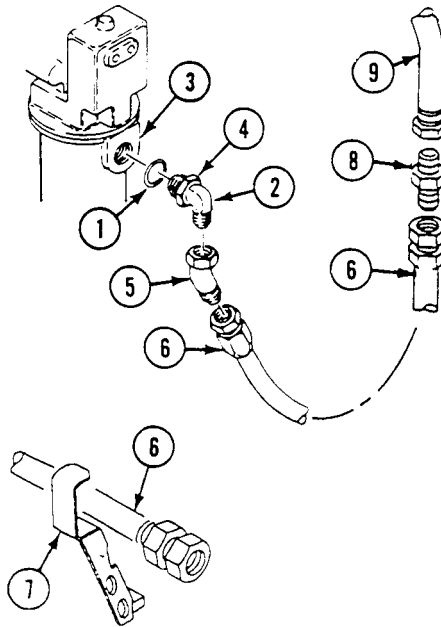
**CAUTION**

Contamination of control valves can cause transmission failure. Make sure dirt does not get into control valves while top cover is removed.

NOTE

If elbow was removed, do Steps 15 - 24.

NOTE

Ensure elbow is pointing in right direction during installation. Use mark made during removal. If needed, temporarily install transmission oil inlet tube on elbow. Ensure top cover can be installed after elbow is tightened.

NOTE

Do Step 15 only for transmissions without an elbow adapter.

REPLACE TRANSMISSION OIL COOLER HOSES, FITTINGS, AND MOUNTING —
Continued

0399 00

15. Lubricate new preformed packing (10) with a thin coat of petrolatum. Install packing and elbow (11) in right end cover (12). Verify proper alignment of elbow. **TIGHTEN LOCKNUT (13) TO 159-175 LB-FT (216-237 N·m) TORQUE.**

NOTE

Do Step 16 and Step 17 only for transmissions equipped with an adapter for elbow (11).

16. Lubricate new preformed packing (10) with a thin coat of petrolatum. Install packing and adapter (14) in right end cover (12). **TIGHTEN ADAPTER TO 127-140 LB-FT (172-190 N·m) TORQUE.**
17. Install elbow (11) on adapter (14). Hold adapter. **TIGHTEN ELBOW TO 160-182 LB-FT (217-247 N·m) TORQUE.**
18. Place new gasket (15) and top cover (16) on transmission (17).

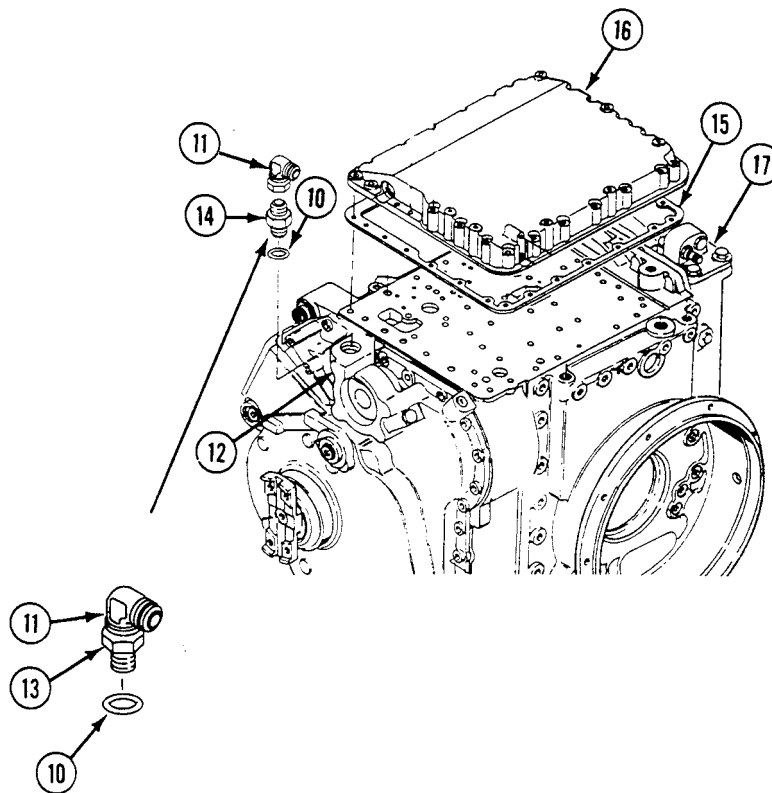

NOTE

Three different length lockscrews are used to secure top cover. Ensure all lockscrews are located properly before tightening.

19. Secure top cover (1) to transmission housing (2) with 15 lockscrews (3), two lockscrews (4), and nine lockscrews (5). TIGHTEN ALL LOCKSCREWS TO 156-180 LB-IN (18-20 N·m) TORQUE.
20. Install reducer (18) in top of transmission housing (2). TIGHTEN REDUCER TO 144-192 LB-IN (16-22 N·m) TORQUE.
21. Install breather (19) in reducer (18). TIGHTEN BREATHER TO 168-192 LB-IN (19-22 N·m) TORQUE.
22. Install lifting bracket (7) with bracket leaning towards the center of the transmission, two washers (20), and new lockscrews (21) on left end cover (22).
23. Install lifting bracket (8) with bracket leaning towards the center of the transmission, two washers (23), and new lockscrews (24) on right end cover (25).
24. TIGHTEN LOCKSCREWS (21) AND (24) TO 156-180 LB-IN (18-20 N·m) TORQUE.

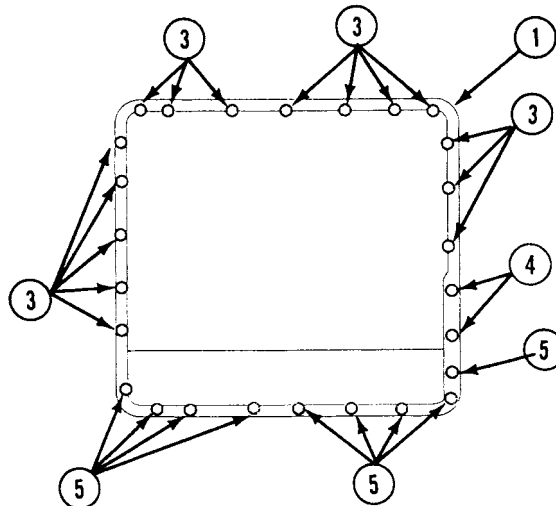
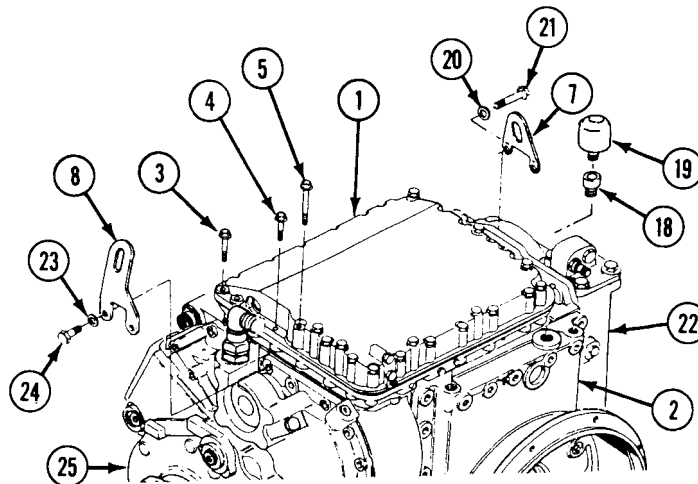

REPLACE TRANSMISSION OIL COOLER HOSES, FITTINGS, AND MOUNTING —
Continued

0399 00

25. Install transmission oil inlet tube (9) on elbow (10).
26. Install transmission oil inlet hose (6), clamp (11), two washers (12), screw (13), and new locknut (14) on bracket (15).
27. Secure wiring harness (16) to transmission oil inlet tube (9) with two new straps (17).

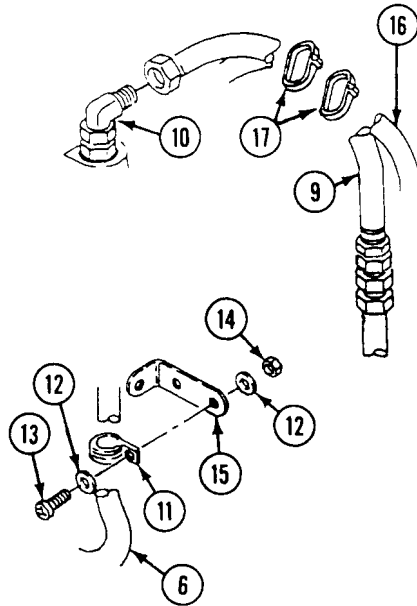
**FOLLOW-THROUGH STEPS**

1. Fill transmission with oil (WP 0398 00).
2. Install power plant (WP 0156 00).

END OF TASK

REPLACE TRANSMISSION OIL SAMPLING VALVE AND PRESSURE SWITCH

0400 00**THIS WORK PACKAGE COVERS:**

Removal (page 0400 00-1).
Installation (page 0400 00-3).

INITIAL SETUP:Maintenance Level

Unit

References

See your -10

Tools and Special Tools

General Mechanic's Tool Kit (WP 0926 00, Item 65)

Materials/Parts

Sealing compound (WP 0928 00, Item 56)

Preformed packing

Retainer

Equipment Condition

Engine stopped (see your -10)

Carrier blocked (see your -10)

Trim vane lowered (see your -10)

Personnel Required

Unit Mechanic

Power plant access door opened (see your -10)

REMOVAL

1. Remove valve (1) from bushing (2).

REPLACE TRANSMISSION OIL SAMPLING VALVE AND PRESSURE SWITCH —
Continued

0400 00

2. Remove bushing (2) from tee (3).
3. Disconnect circuit 366 lead (4) from switch (5).
4. Remove switch (5) from tee (3).
5. Remove tee (3) with tube nut (6), retainer (7), and preformed packing (8) from transmission. Discard packing and retainer.

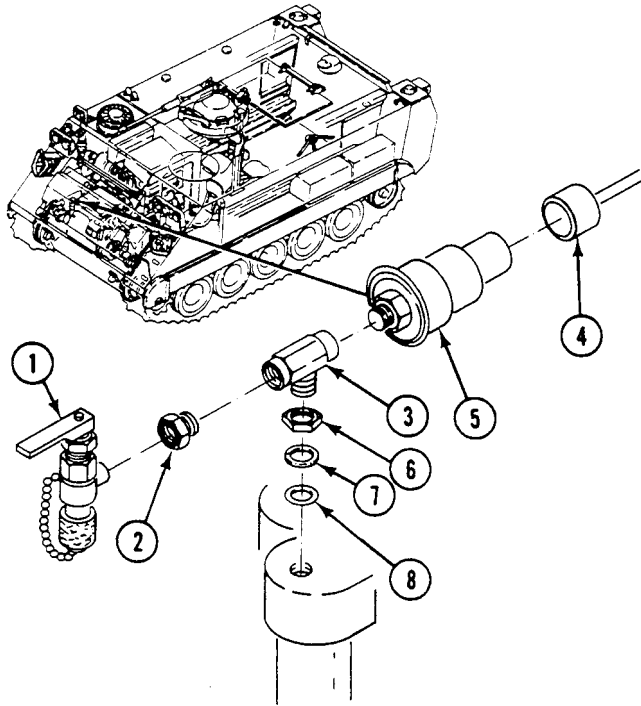

REPLACE TRANSMISSION OIL SAMPLING VALVE AND PRESSURE SWITCH —
Continued

0400 00

INSTALLATION

1. Install new preformed packing (8), new retainer (7), and tee (3) with tube nut (6) on transmission.
2. Apply sealing compound to male threads of switch (5), and install switch in tee (3).
3. Connect circuit 366 lead (4) to switch (5)
4. Apply sealing compound to male threads of bushing (2), and install bushing in tee (3).
5. Install valve (1) in bushing (2).

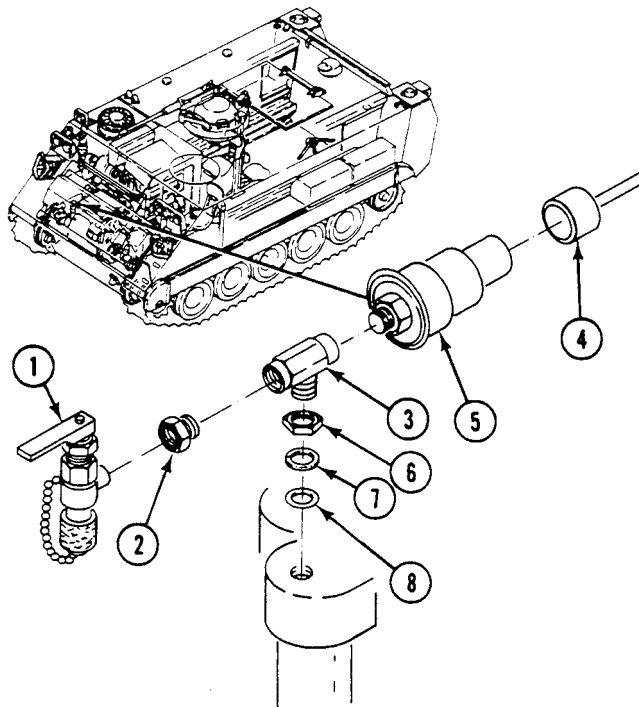
**FOLLOW-THROUGH STEPS**

1. Close power plant access door (see your -10).
2. Raise trim vane (see your -10).

END OF TASK

REPLACE DIFFERENTIAL PRESSURE SWITCH AND BYPASS PLUG

0401 00

THIS WORK PACKAGE COVERS:

Removal (page 0401 00-1).
 Installation (page 0401 00-2).

INITIAL SETUP:

Maintenance Level

Unit

References

See your -10

Tools and Special Tools

General Mechanic's Tool Kit (WP 0926 00, Item 65)

Equipment Condition

Engine stopped (see your -10)
 Carrier blocked (see your -10)
 Power plant access door open (see your -10)

Materials/Parts

Preformed packing (2)
 Preformed packing
 Preformed packing

Personnel Required

Unit Mechanic

REMOVAL

1. Disconnect electrical connector (1) from switch (2) on filter head (3).
2. Remove switch (2), packing (4), and packing (5) from filter head (3). Discard packings.
3. Remove plug (6), packing (4), and packing (7) from filter head (3). Discard packings.

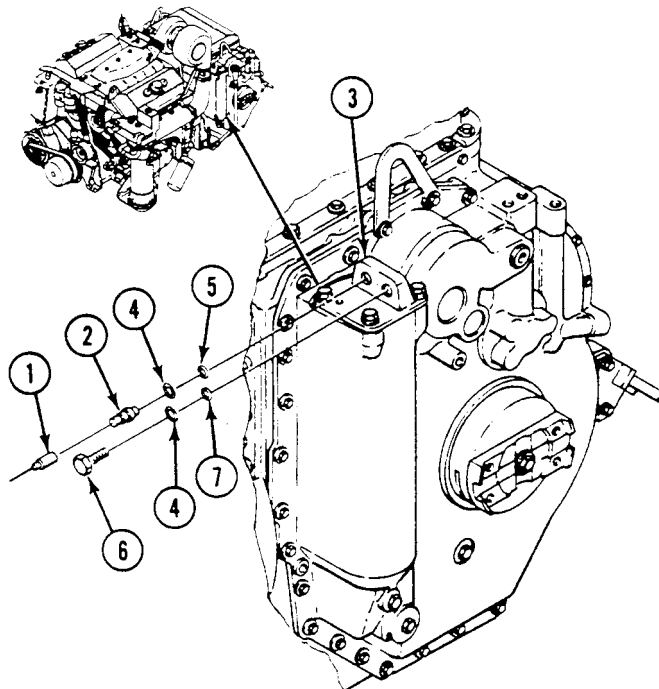

INSTALLATION

1. Install new packing (7), new packing (4), and plug (6) in filter head (3).
2. Install new packing (5), new packing (4), and switch (2) in filter head (3).
3. Connect electrical connector (1) to switch (2) on filter head (3).

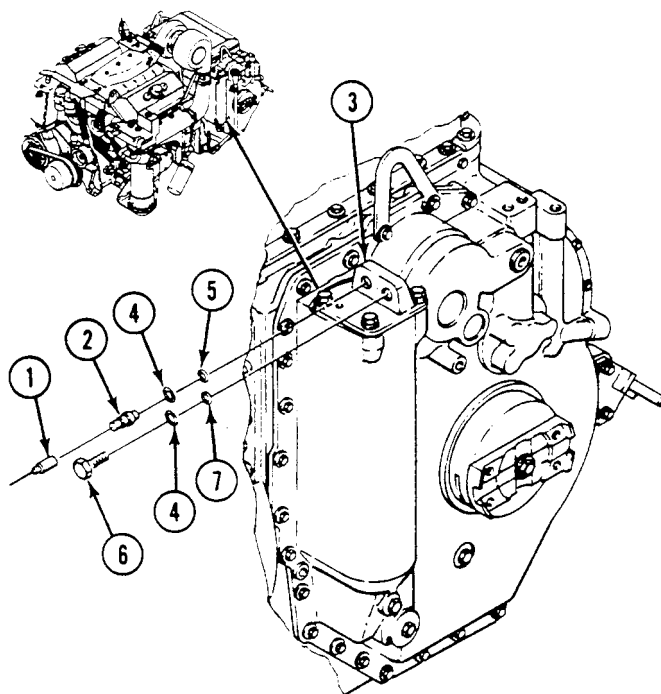
**FOLLOW-THROUGH STEPS**

1. Close power plant access door (see your -10).

END OF TASK

CHAPTER 10

UNIT MAINTENANCE INSTRUCTIONS
FOR TRANSFER AND FINAL DRIVE ASSEMBLIES

WORK PACKAGE INDEX

<u>Title</u>	<u>Sequence No.</u>
REPLACE FINAL DRIVE FILLER TUBE AND DIPSTICK.....	.0402 00
REPLACE FINAL DRIVE.....	.0403 00
REPLACE FINAL DRIVE DIFFERENTIAL OIL SEAL.....	.0404 00

REPLACE FINAL DRIVE FILLER TUBE AND DIPSTICK

0402 00

THIS WORK PACKAGE COVERS:

Removal (page 0402 00-1).
 Installation (page 0402 00-3).

INITIAL SETUP:

Maintenance Level

Unit

Personnel Required

Unit Mechanic

Tools and Special Tools

General Mechanic's Tool Kit (WP 0926 00, Item 65)

References

See your -10

Materials/Parts

Antiseize Compound (WP 0928 00, Item 11)
 Sealing Compound (WP 0928 00, Item 56)
 Preformed packing
 Tablock washer

Equipment Condition

Trim vane lowered (see your -10)
 Power plant front access door open (see your -10)
 Final drive removed (WP 0403 00)

REMOVAL

1. Turn dipstick (1) to the left and remove from oil filler tube (2).
2. Remove screw (3), tablock washer (4), and clamp (5) from final drive (6). Discard tablock washer.

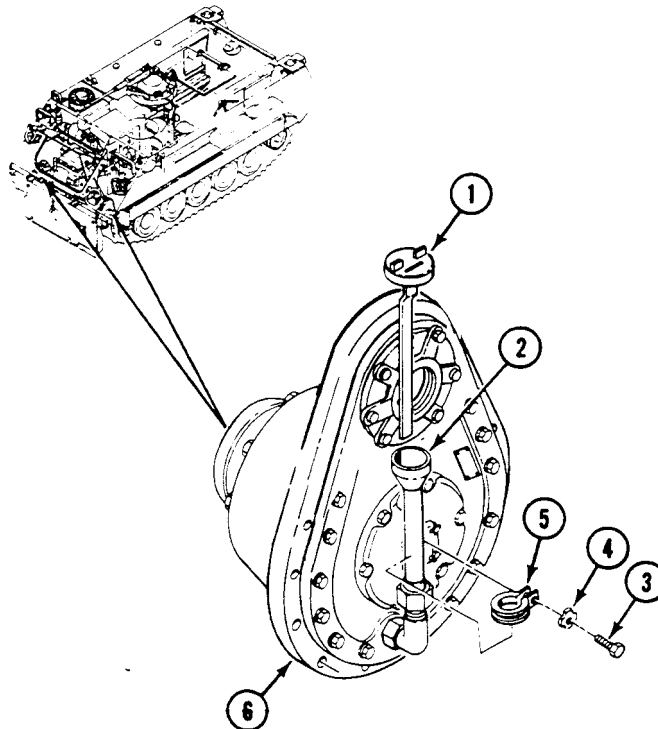

REPLACE FINAL DRIVE FILLER TUBE AND DIPSTICK — Continued

0402 00

3. Remove nut (7) from elbow (8).
4. Remove vent tube (9) from elbow (10).
5. Remove filler tube (2) and vent tube (9) from final drive (6).
6. Remove elbow (10) from final drive (6).
7. Loosen nut (11). Remove elbow (8) and preformed packing (12) from final drive (6). Discard packing.

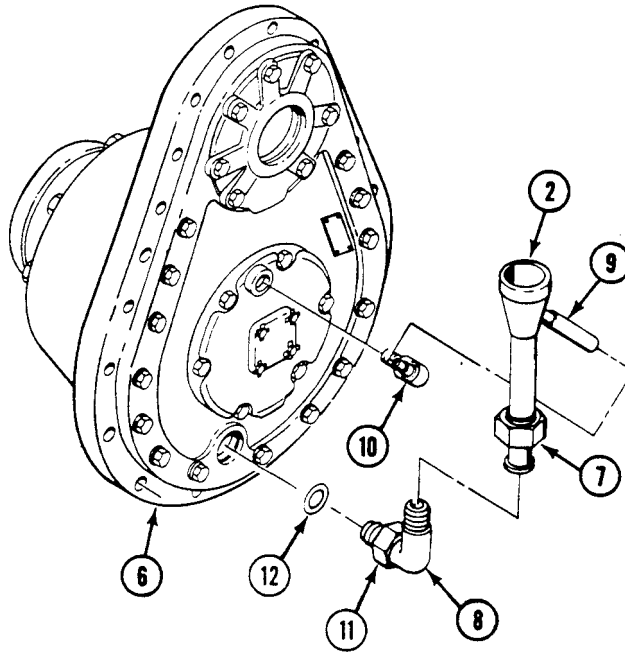

INSTALLATION

1. Install new preformed packing (1) and elbow (2) in final drive (3). Secure with nut (4).
2. Apply a light coat of sealing compound to threads of elbow (5).
3. Install elbow (5) in final drive (3).
4. Install vent tube (6) on elbow (5).
5. Connect filler tube (7) to vent tube (6) and elbow (2). Do not tighten nut (8).

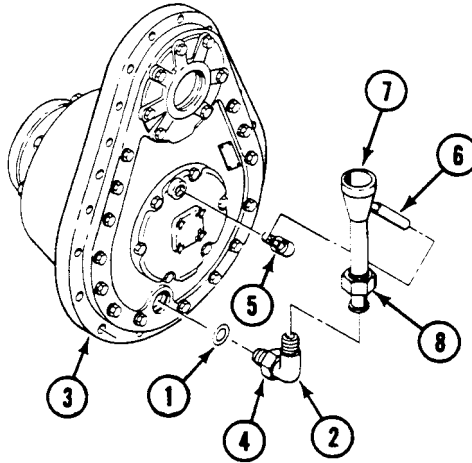

6. Apply a light coat of antiseize compound to threads of screw (9).
7. Secure filler tube (7) to final drive (3) with clamp (10), new tablock washer (11), and screw (9).

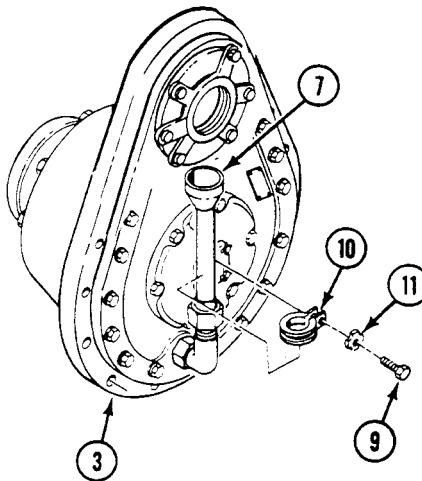

8. Tighten nut (8) to secure filler tube (7) to elbow (2).
9. Install dipstick (12) in filler tube (7) and turn to the right to lock.

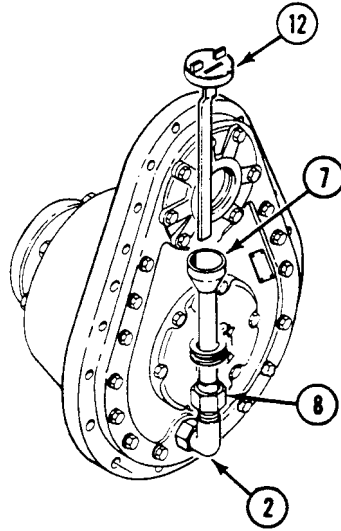
**FOLLOW-THROUGH STEPS**

1. Install final drive (WP 0403 00).
2. Close power plant front access door (see your -10).
3. Raise trim vane (see your -10).

END OF TASK

REPLACE FINAL DRIVE

0403 00

THIS WORK PACKAGE COVERS:

- Removal (page 0403 00-1).
- Cleaning, Inspection, and Repair (page 0403 00-2).
- Installation (page 0403 00-3).

INITIAL SETUP:

Maintenance Level

Unit

Tools and Special Tools

- General Mechanic's Tool Kit (WP 0926 00, Item 65)
- Lifting Bar (WP 0926 00, Item 8)
- Torque Wrench (WP 0926 00, Item 81)

Materials/Parts

- Antiseize compound (WP 0928 00, Item 11)
- Cleaning compound (WP 0928 00, Item 19)

Personnel Required

Unit Mechanic

References

- See your -10
(WP 0155 00)

Equipment Condition

- Engine stopped (see your -10)
- Carrier blocked (see your -10)
- Trim vane lowered (see your -10)
- Power plant front access door
opened (see your -10)
- Final drive yoke removed (WP 0405 00)
- Track removed from drive sprocket (WP 0422 00)
- Track drive sprocket removed from
final drive (WP 0420 00)
- Track cover removed (WP 0438 00)

REMOVAL

1. If left final drive is to be removed, remove hull front access cover (WP 0449 00). Remove left final drive speedometer cable and adapter (WP 0422 00).

2. Drain final drive (WP 0155 00).

WARNING



The final drive is heavy and can cause back injury if handled improperly. Be sure to use a hoist or a helper to remove final drive.

3. Secure lifting bar (1) to final drive (2) with two sprocket mounting screws (3).
4. Attach suitable lifting device of at least 165 lb (75 kg) capacity to lifting bar (1).
5. Remove 17 screws (4), washers (5), and final drive (2) from hull (6).

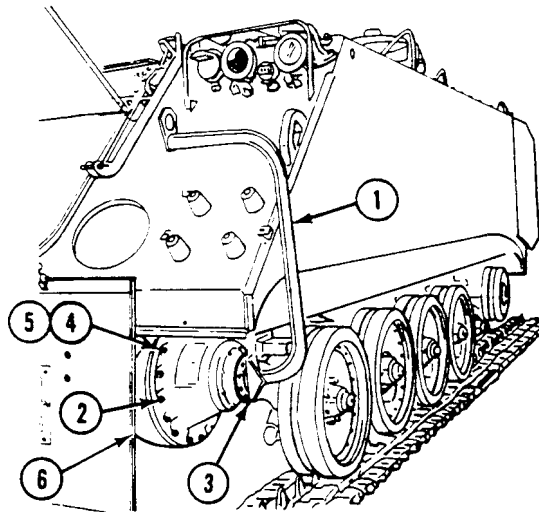

CLEANING, INSPECTION, AND REPAIR

1. Clean final drive and hull mounting surface with dry cleaning solvent.
2. Replace final drive that shows cracks or leaks other than differential oil seal leak. Leaking differential oil seal can be replaced (WP 0404 00).
3. Check mounting surfaces and internal spline for breaks, nicks, deep scratches and burrs. Repair minor damage. Replace final drive if damage cannot be repaired.

INSTALLATION

1. Check final drive drain plug for tightness.
2. If left final drive is to be replaced, remove speedometer shaft adapter from old final drive and install it in new final drive (WP 0860 00).
3. Fill final drive with oil (WP 0155 00).
4. Secure lifting bar (1) to final drive (2) with two sprocket mounting screws (3).
5. Attach lifting device of at least 165 lb (75 kg) capacity to lifting bar (1) and position final drive (2) on hull (6).
6. Apply antiseize compound to threads of 17 screws (4).
7. Secure final drive (2) to hull (6) with 17 screws (4) and washers (5). **TIGHTEN SCREWS TO 75-85 LB-FT (102-115 N·m) TORQUE.**
8. Remove two screws (3) and lifting bar (1) from final drive (2).

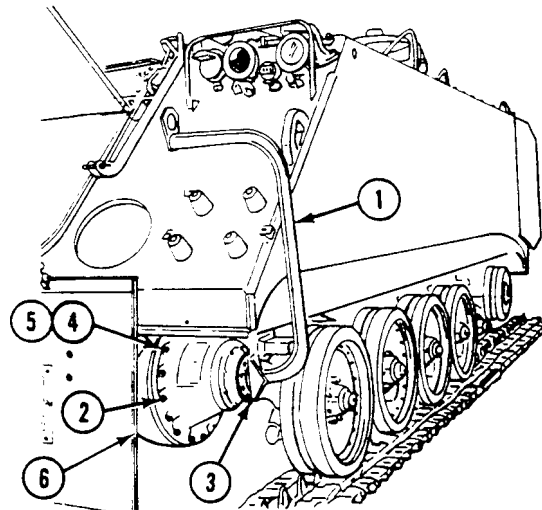

FOLLOW-THROUGH STEPS

1. Install final drive yoke (WP 0405 00).
2. Install drive sprocket on final drive (WP 0422 00).
3. Install track on drive sprocket (WP 0422 00).
4. Install track cover (WP 0438 00).
5. Install speedometer cable on adapter (left final drive only) (WP 0422 00).
6. Install hull front access cover (left final drive only) (WP 0449 00).
7. Close power plant front access door (see your -10).
8. Raise trim vane (see your -10).
9. Remove blocks used to keep carrier from moving (see your -10).
10. Road test carrier (WP 0155 00) to check final drive.

END OF TASK

REPLACE FINAL DRIVE DIFFERENTIAL OIL SEAL

0404 00

THIS WORK PACKAGE COVERS:

Removal (page 0404 00-1).
 Installation (page 0404 00-2).

INITIAL SETUP:

Maintenance Level

Unit

Personnel Required

Unit Mechanic

Tools and Special Tools

General Mechanic's Tool Kit (WP 0926 00, Item 65)
 Torque Wrench (WP 0926 00, Item 81)

References

See your -10

Materials/Parts

Antiseize compound (WP 0928 00, Item 11)
 Sealing compound (WP 0928 00, Item 56)
 Gasket
 Seal
 Lock screw (3)
 Lock screw (4)

Equipment Condition

Carrier blocked (see your -10)
 Trim vane lowered (see your -10)
 Power plant front access door opened (see your -10)
 Drive shaft removed (WP 0405 00)
 Final drive yoke removed (WP 0405 00)
 Hull front access cover removed (left final drive only)
 (WP 0449 00)

REMOVAL

1. Remove seven lock screws (1), washers (2), cover (3), and gasket (4) from final drive (5). Discard gasket and lock screws.
2. Remove seal (6) from cover (3). Discard seal.

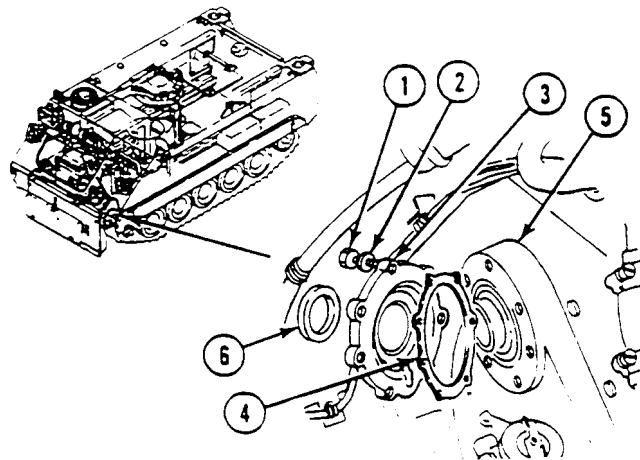

INSTALLATION

1. Apply sealing compound to new seal (6). Install in cover (3) flush with surface of cover.
2. Apply a light coat of antiseize compound to threads of seven new lock screws (1).
3. Install new gasket (4) and cover (3) on final drive (5). Secure with seven new lock screws (1) and washers (2).
TIGHTEN SCREWS TO 21-25 LB-FT (28-34 N·m) TORQUE.

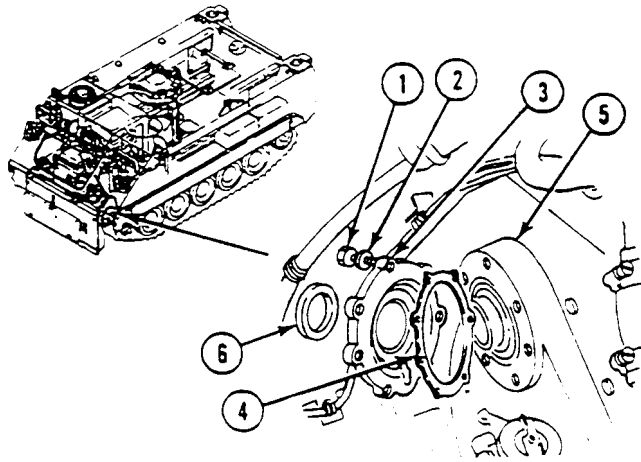
**FOLLOW-THROUGH STEPS**

1. Install final drive yoke (WP 0405 00).
2. Install drive shaft (WP 0405 00).
3. Install hull front access cover (left final drive only) (WP 0449 00).
4. Close power plant front access door (see your -10).
5. Raise trim vane (see your -10).
6. Remove blocks used to keep carrier from moving (see your -10).
7. Road test carrier (WP 0155 00) to check final drive. Check for leaks around seal.

END OF TASK

CHAPTER 11

UNIT MAINTENANCE INSTRUCTIONS
FOR PROPELLER SHAFTS AND UNIVERSAL JOINTS

WORK PACKAGE INDEX

<u>Title</u>	<u>Sequence No.</u>
REPLACE PROPELLER SHAFT AND UNIVERSAL JOINTS.....	0405 00

REPLACE PROPELLER SHAFT AND UNIVERSAL JOINTS

0405 00

THIS WORK PACKAGE COVERS:

Removal (page 0405 00-1.
 Installation (page 0405 00-3.

INITIAL SETUP:

Maintenance Level

Unit

Personnel Required

Unit Mechanic
 Helper (H)

Tools and Special Tools

General Mechanic's Tool Kit (WP 0926 00, Item 65)
 Torque Wrench Adapter (WP 0926 00, Item 4)
 Vise (WP 0926 00, Item 68)
 Torque Wrench (WP 0926 00, Item 85)

References

See your -10

Equipment Condition

Engine stopped (see your -10)
 Carrier blocked (see your -10)
 Trim vane lowered (see your -10)
 Power plant front access door open (see your -10)
 Hull front access cover removed (WP 0449 00)

Materials/Parts

Screw (16)
 Washer (16)

REMOVAL

NOTE

Procedure for replacement of propeller shafts and universal joints are the same for right and left side.

NOTE

Loosen accessible screws only enough to relieve torque. Move carrier to gain access to remaining screws.

REPLACE PROPELLER SHAFT AND UNIVERSAL JOINTS — Continued

0405 00

1. Remove eight screws (1) and washers (2) from universal joints (3) and slide yoke (4) into final drive (5). Discard screws and washers.
2. Remove propeller shaft (6) with universal joints (3) from carrier.
3. Position propeller shaft (6) in vise. Remove eight screws (7) and washers (8) from universal joints (3) and shaft. Discard screws and washers.
4. Remove yoke (4) from final drive (5).

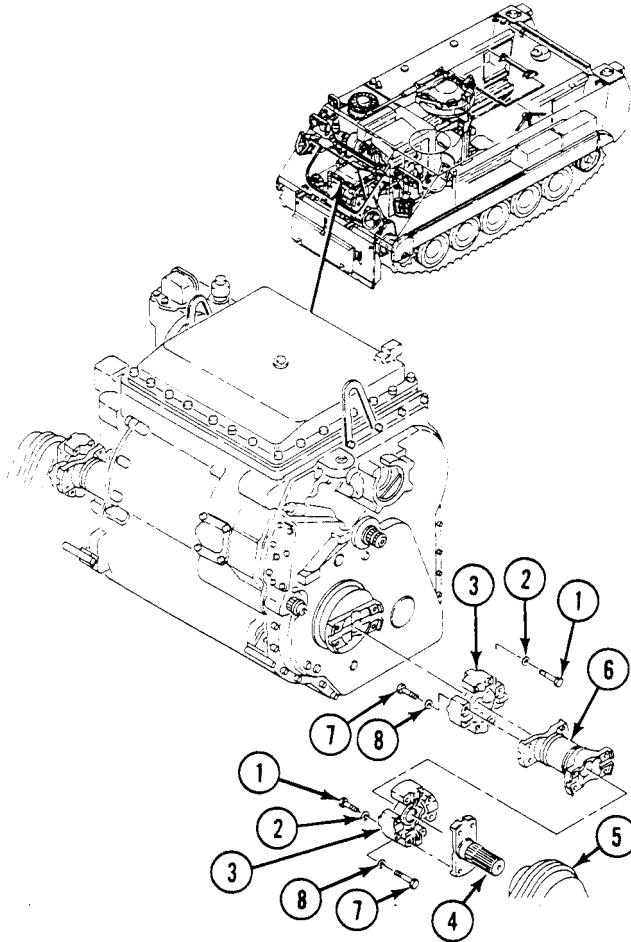

INSTALLATION

NOTE

After installation of one propeller shaft, transmission will not rotate. A helper is required (with tanker bar) to move carrier to align holes of universal joint with yoke for installation of propeller shaft on the other side.

NOTE

If not replacing permanently lubricated universal joints, install two lube fittings in each universal joint.

NOTE

Screws and washers must be clean, dry, and free of lubricant and paint. Washers must be 5/32 inch (4 mm) hardened flat steel only.

1. Install yoke (1) in final drive (2).

NOTE

When using torque wrench with torque wrench adapter, torque value must be corrected. See (WP 0155 00) for procedure for converting torque value.

2. Position propeller shaft (3) in vise and install universal joints (4) with eight new screws (5) and new washers (6). TIGHTEN SCREWS TO 86-94 LB-FT (117-127 N·m) TORQUE. LOOSEN SCREWS, THEN TIGHTEN AGAIN TO 86-94 LB-FT (117-127 N·m) TORQUE.
3. Position propeller shaft (3) with universal joints and secure to transmission and final drive (2) with eight new screws (7) and new washers (8). TIGHTEN SCREWS TO 86-94 LB-FT (117-127 N·m) TORQUE. LOOSEN SCREWS, THEN TIGHTEN AGAIN TO 86-94 LB-FT (117-127 N·m) TORQUE.

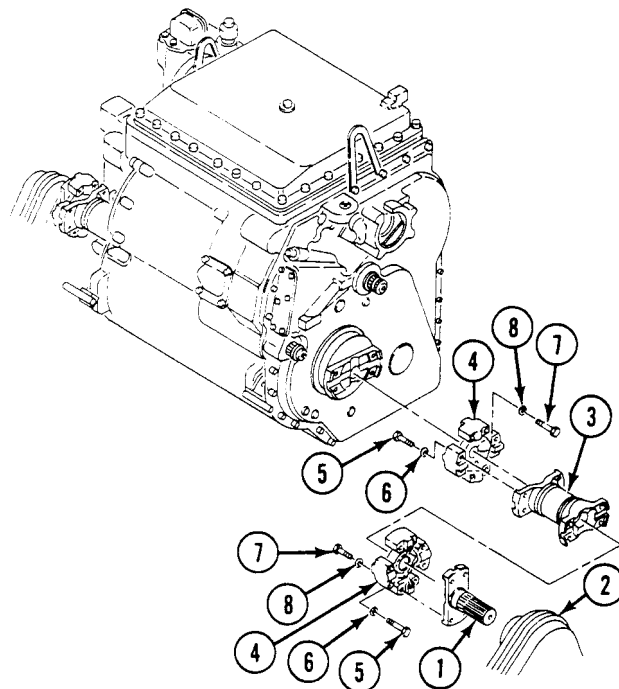

NOTE

Perform Step 4 if permanently lubricated universal joints have not been installed.

4. Lubricate universal joints (WP 0155 00).

FOLLOW-THROUGH STEPS

1. Install hull front access cover (WP 0449 00).
2. Close power plant front access door (see your -10).
3. Raise trim vane (see your -10).

END OF TASK

CHAPTER 12
UNIT MAINTENANCE INSTRUCTIONS
FOR BRAKES

WORK PACKAGE INDEX

<u>Title</u>	<u>Sequence No.</u>
CHECK TRANSMISSION BRAKE ADJUSTMENT.....	.0406 00
ADJUST SERVICE BRAKE CONTROL LINKAGE.....	.0407 00
ADJUST PARKING BRAKE0408 00
REPLACE UPPER AND LOWER SERVICE BRAKE PEDAL.....	.0409 00
REPLACE SERVICE BRAKE CONTROL LINKAGE0410 00
REPLACE PARKING BRAKE CONTROL CABLE ASSEMBLY.....	.0411 00
REPLACE PARKING BRAKE CONTROL LEVER ASSEMBLY0412 00

CHECK TRANSMISSION BRAKE ADJUSTMENT

0406 00

THIS WORK PACKAGE COVERS:

Check brake adjustment (page 0406 00-1).

INITIAL SETUP:

Maintenance Level

Unit

References

See your -10

Tools and Special Tools

General Mechanic's Tool Kit (WP 0926 00, Item 65)

Torque Wrench (WP 0926 00, Item 85)

Equipment Condition

Engine stopped (see your -10)

Carrier blocked (see your -10)

Trim vane lowered (see your -10)

Power plant front access door opened (see your -10)

Hull front access cover removed (WP 0449 00)

Parking brake released (see your -10)

Personnel Required

Unit Mechanic

Helper (H)

INSPECTION OF INSTALLED ITEMS

CHECK BRAKE ADJUSTMENT

1. (H) Start engine and allow to warm up (see your -10).
2. Watch brake shaft indicators (1) and (2) through power plant front access hole (3).

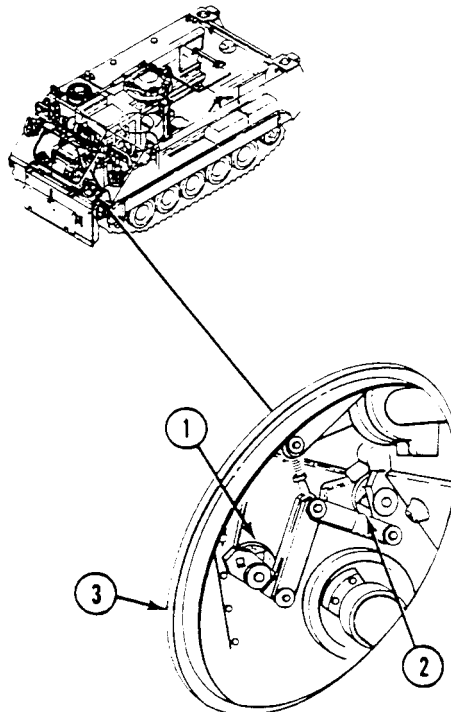

3. (H) Apply 104 lb-ft (141 N.m) torque to brake shaft nut (4).

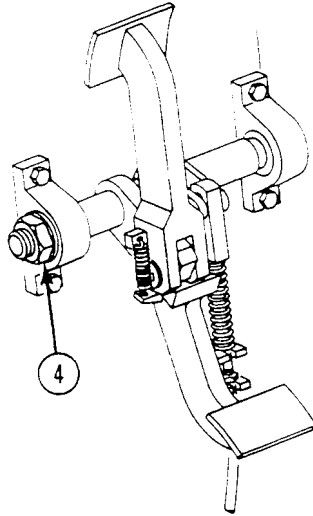

4. If transmission is not in the carrier or if the linkage is not connected to the transmission, apply 40 lb-ft (54 N.m) torque to arms (5) and (6).

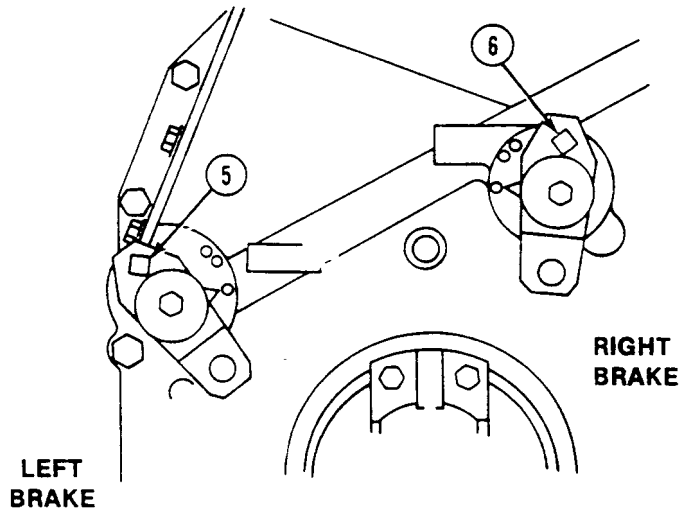

CHECK TRANSMISSION BRAKE ADJUSTMENT — Continued

0406 00

5. Note position of indicators (1) and (2). If indicators stop before APPLY mark (3), check brake linkage adjustment and adjust brakes (WP 0394 00).

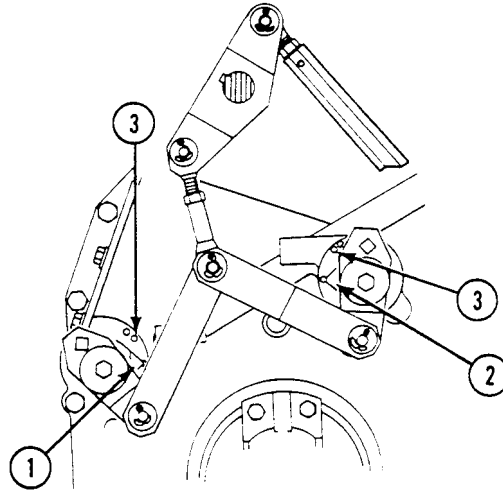

6. If indicators (1) and (2) indicate or go past ADJUST mark (4), adjust brakes (WP 0394 00).

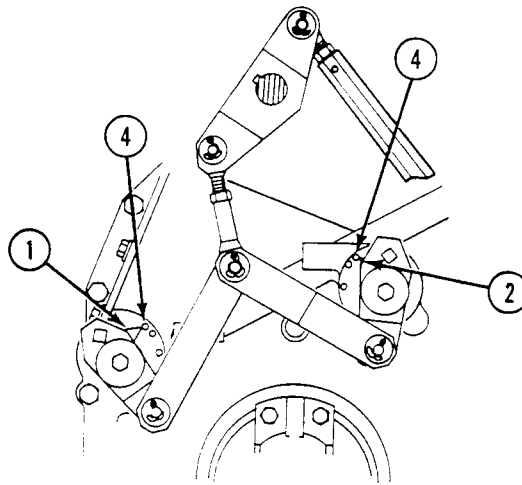
**FOLLOW-THROUGH STEPS**

1. Apply parking brake (see your -10).
2. Install hull front access cover (WP 0449 00).
3. Close power plant front access door (see your -10).
4. Raise trim vane (see your -10).

END OF TASK

ADJUST SERVICE BRAKE CONTROL LINKAGE

0407 00

THIS WORK PACKAGE COVERS:

Adjustment (page 0407 00-1).

INITIAL SETUP:

Maintenance Level

Unit

References

See your -10

Tools and Special Tools

General Mechanic's Tool Kit (WP 0926 00, Item 65)

Equipment Condition

- Engine stopped (see your -10)
- Carrier blocked (see your -10)
- Trim vane lowered (see your -10)
- Power plant front access door opened (see your -10)
- Driver's power plant access panel removed (see your -10)
- Hull front access cover removed (WP 0449 00)
- Transmission brake adjustment checked (WP 0406 00)

Materials/Parts

Cotter pin

Personnel Required

Unit Mechanic
Helper (H)

ADJUSTMENT

1. Remove cotter pin (1), two washers (2), clevis pin (3), and linkage rod (4) from cross-shaft link (5). Discard cotter pin.

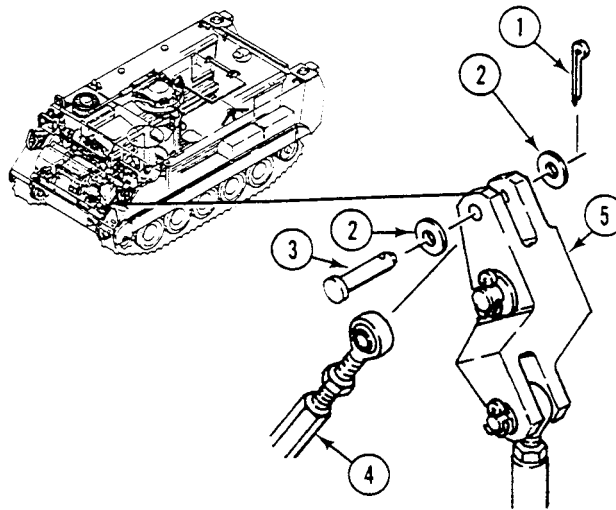

2. (H) Hold lower brake pedal (6) in OFF position, 7-11/16 to 7-3/16 inches (19.5 to 18.3 cm) above driver's floor plate (7).

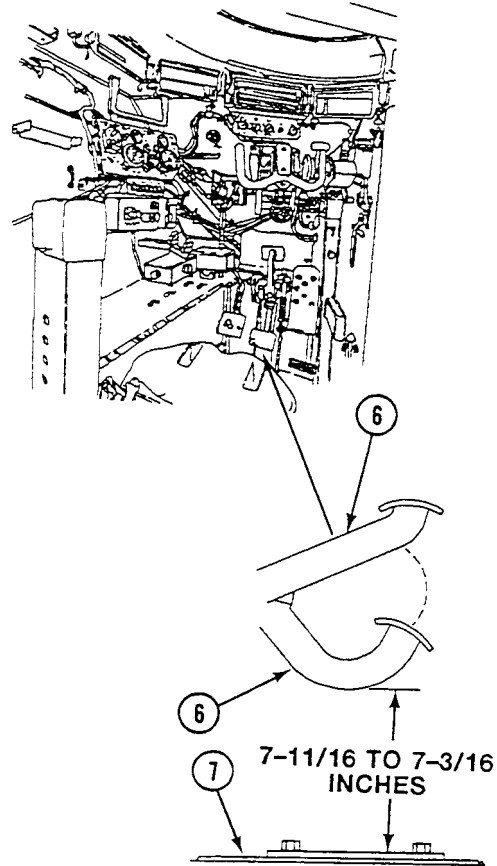

3. Move cross-shaft link (1) until left and right hand brake apply shaft indicators (2) and (3) point to lowest marks on transmission casing (4) and (5).

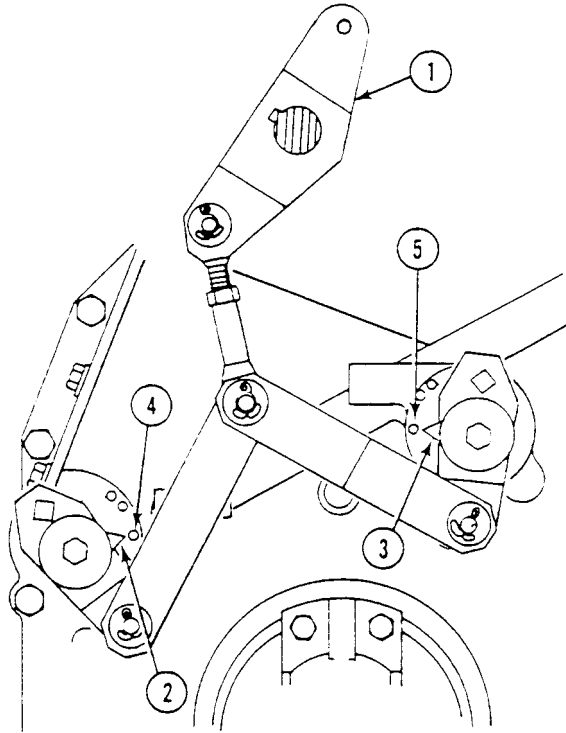

4. Loosen jam nut (6) on linkage rod (7). Install rod on cross-shaft link (1).
5. Adjust length of linkage rod (7) by turning rod end bearing (8) until clevis pin (9) inserts freely into bearing and cross-shaft link (1). Tighten jam nut (6).

WARNING

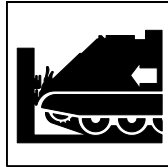

**Failure of control linkage can cause carrier to crash. Crash could kill or injure personnel.
Install NEW cotter pin.**

6. Secure linkage rod end bearing (8) to cross-shaft link (1) with two washers (10), clevis pin (9), and new cotter pin (11).

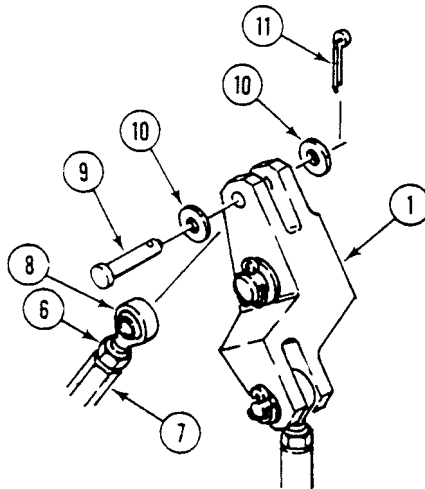
FOLLOW-THROUGH STEPS

1. Install hull front access cover (WP 0449 00).
2. Install driver's power plant access panel (see your -10).
3. Close power plant front access door (see your -10).
4. Raise trim vane (see your -10).

END OF TASK

ADJUST PARKING BRAKE

0408 00

THIS WORK PACKAGE COVERS:

Adjustment (page 0408 00-1).

INITIAL SETUP:

Maintenance Level

Unit

Personnel Required

Unit Mechanic

Tools and Special Tools

General Mechanic's Tool Kit (WP 0926 00, Item 65)

References

See your -10

Materials/Parts

Cotter pin

Equipment Condition

Engine stopped (see your -10)

Carrier blocked (see your -10)

ADJUSTMENT

1. Check for 3/4 inch (1.9 cm) minimum thread engagement of cable (1) and stop (2). If you find 3/4 inch (1.9 cm) minimum thread engagement, go to Step 8 below. If not, do Steps 1 - 9 below.

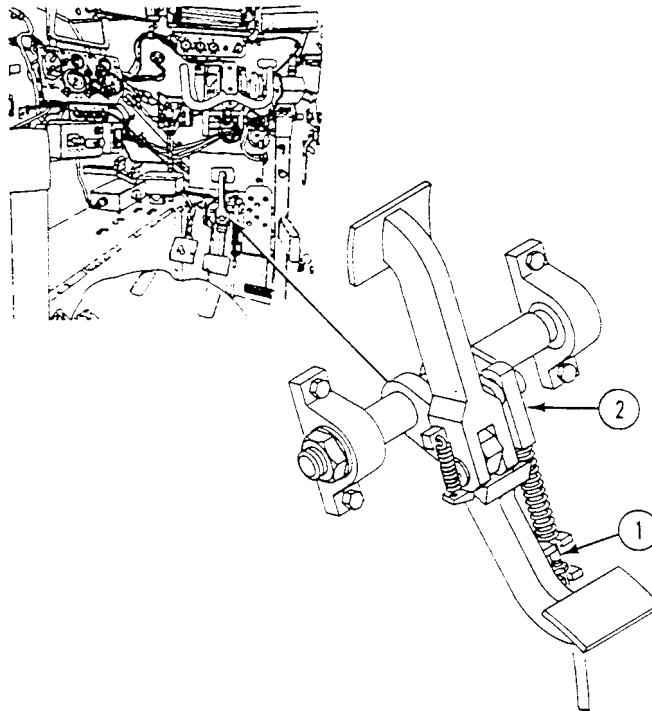

2. Position parking lever (3) in full off position by pushing lever handle down.
3. Turn brake lever adjustment knob (4) on end of lever (3) to the left to allow full slack in control assembly cable (5).

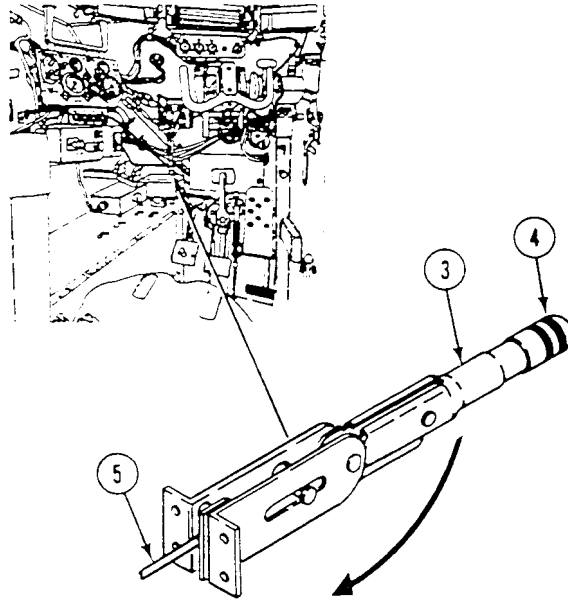

4. Position brake lower pedal (6) in full off position, 7-11/16 to 7-3/16 inches (19.5 to 18.3 cm) above the driver's floor plate.

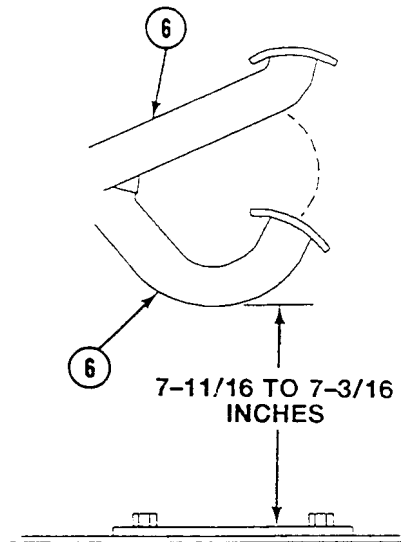

5. Remove cotter pin (1), two washers (2), and clevis pin (3) that connect control assembly cable stop (4) to lever link (5). Disconnect cable stop from link. Discard cotter pin.

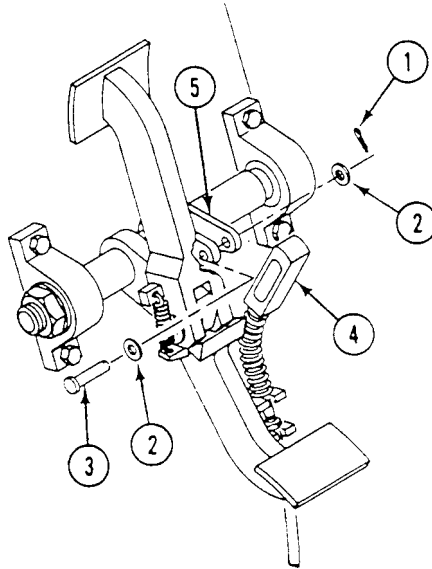

6. Loosen jam nut (6). Allow 3/4 inch (1.9 cm) minimum thread engagement of cable stop (7) on cable end (8). Tighten jam nut against cable stop.
7. Connect cable stop (7) to lever link (9). Secure with clevis pin (10), flat washer (11), and new cotter pin (12).
8. Adjust control assembly cable (13) in bracket (14) by turning two jam nuts (15) until end of cable stop slot (7) is against clevis pin (10) (installed in Step 7) or as close as thread adjustment allows. Tighten both jam nuts.

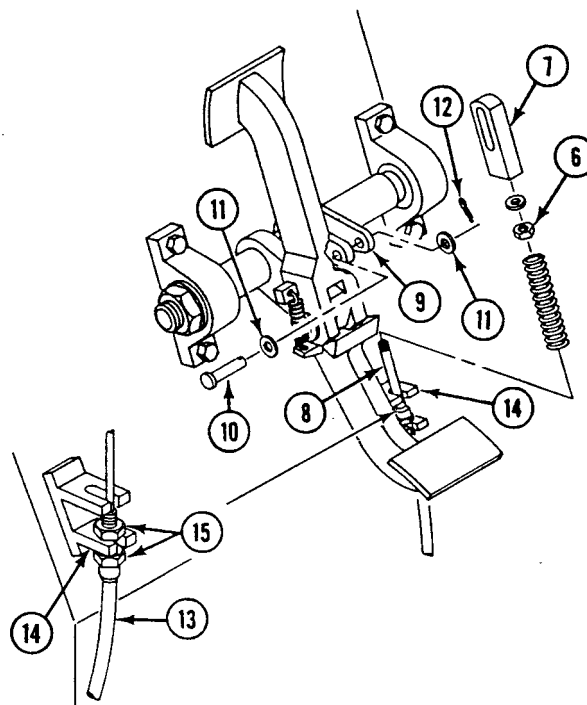

9. Turn brake lever adjustment knob (16) to the right to bring cable stop against clevis pin.

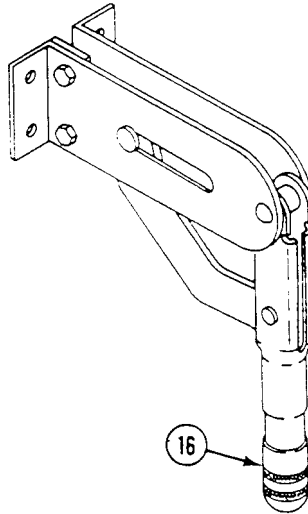
**FOLLOW-THROUGH STEPS**

1. Apply parking brake (see your -10).

END OF TASK

REPLACE UPPER AND LOWER SERVICE BRAKE PEDAL

0409 00

THIS WORK PACKAGE COVERS:

- Removal (page 0409 00-1).
- Installation (page 0409 00-6).

INITIAL SETUP:

Maintenance Level

Unit

Personnel Required

Unit Mechanic
Helper (H)

Tools and Special Tools

- General Mechanic's Tool Kit (WP 0926 00, Item 65)
- Lubricating Gun (WP 0926 00, Item 29)

References

See your -10

Materials/Parts

- Cotter pin (3)
- Cotter pin
- Grommet
- Key
- Locknut
- Lockwasher (4)
- Mount bearing (2)

Equipment Condition

- Engine stopped (see your -10)
- Carrier blocked (see your -10)
- Trim vane lowered (see your -10)
- Power plant front access door opened (see your -10)
- Driver's power plant access panel removed (see your -10)
- Hull front access cover removed (WP 0449 00)

REMOVAL

1. Pull upper brake pedal (1) to upper position. Remove spring (2) that connects both upper and lower brake pedals (1) and (3).

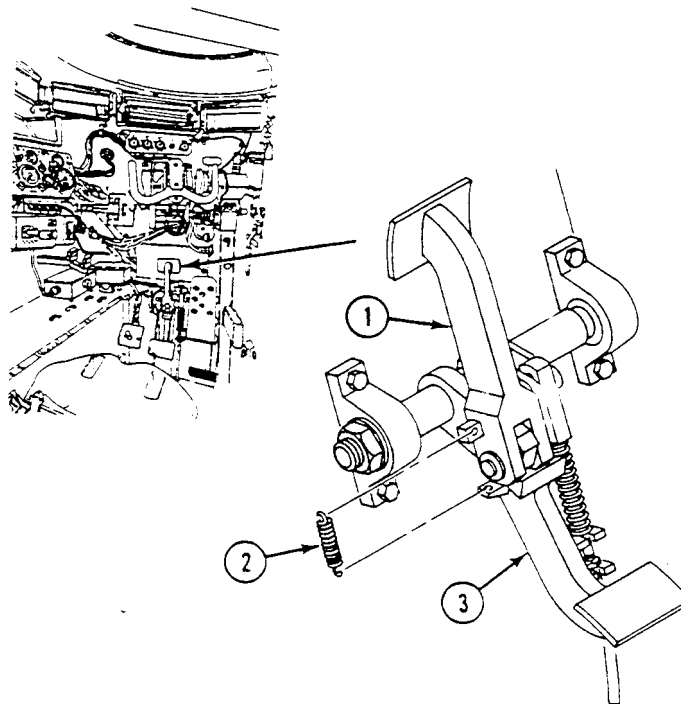

REPLACE UPPER AND LOWER SERVICE BRAKE PEDAL — Continued**0409 00**

2. Remove cotter pin (4), two washers (5), and clevis pin (6) from upper and lower brake pedals (1) and (3). Remove upper pedal from lower pedal. Discard cotter pin.
3. Remove cotter pin (7), two washers (8), clevis pin (9), and cable stop (10) from lower brake pedal lever (11). Discard cotter pin.

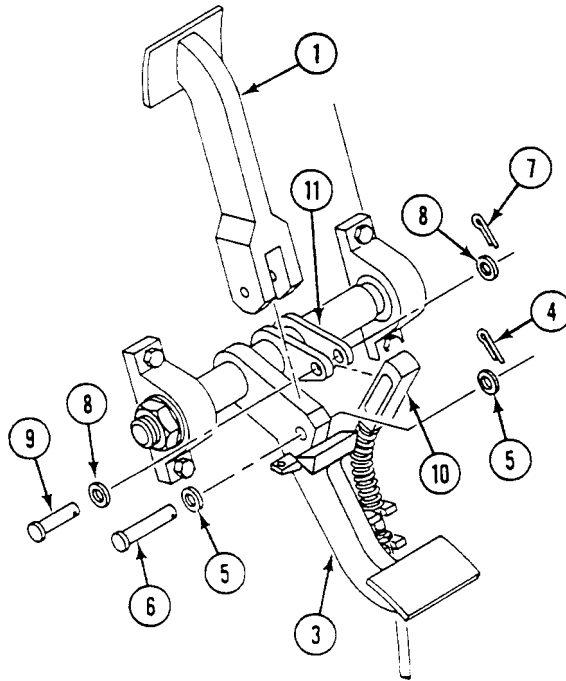

REPLACE UPPER AND LOWER SERVICE BRAKE PEDAL — Continued

0409 00

4. Disconnect starter cannon plug (1) from power plant compartment bulkhead (2).
5. Remove release spring (3) from link (4) and power plant compartment bulkhead (5).
6. Remove cotter pin (6), two washers (7), clevis pin (8), and linkage rod (9) from link (4). Discard cotter pin.

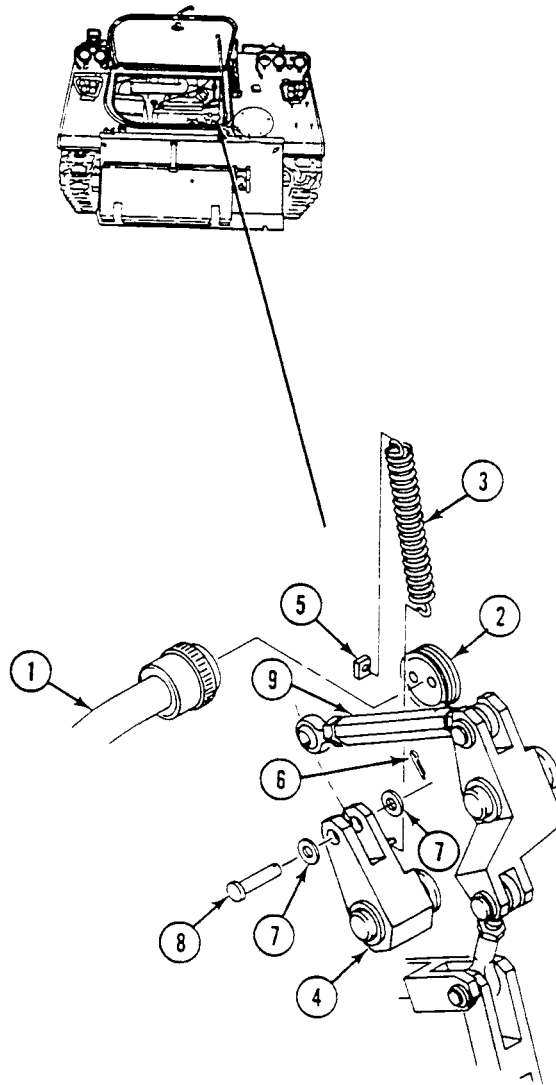

7. Remove cotter pin (10) and washer (11) from link (4) and shaft (12). Slide link as far off shaft as possible. Discard cotter pin.

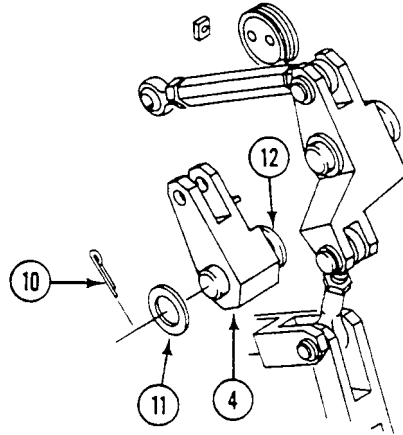

8. Remove four screws (13), washers (14), and lockwashers (15) from two mount bearings (16). Discard lockwashers.
9. Remove shaft with attached bearings (16) from driver's compartment. Have helper assist to catch link (4) in power plant front access hole. Remove grommet (17) from driver's compartment bulkhead. Discard grommet. Remove shaft assembly from carrier.

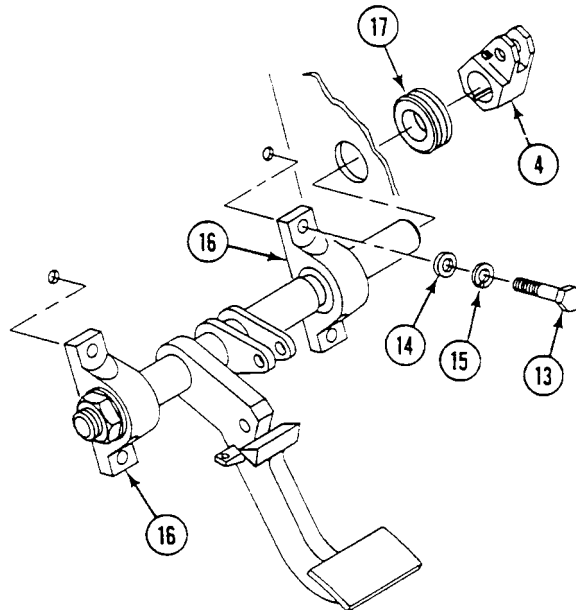

REPLACE UPPER AND LOWER SERVICE BRAKE PEDAL — Continued

0409 00

10. Remove key (1) from shaft (2). Discard key.
11. Remove locknut (3) and washer (4) from shaft (2). Discard locknut.
12. Slide attached mount bearings (5) off shaft (2). Discard bearings.

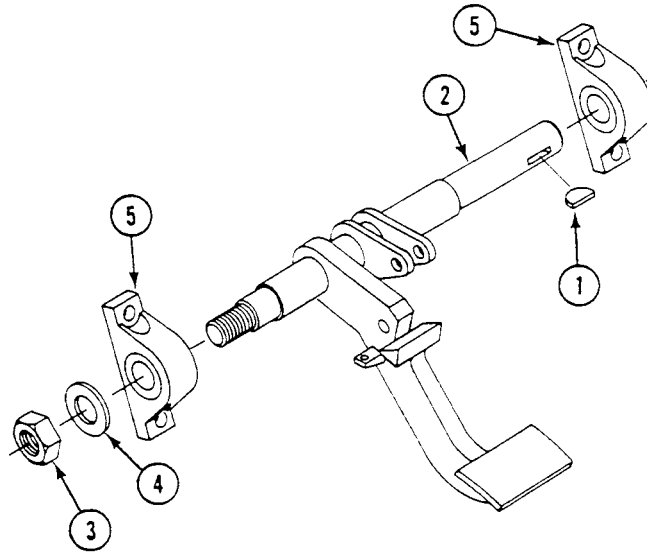

INSTALLATION

1. Grease two new mount bearings (5). See (WP 0155 00).
2. Install two mount bearings (5) on shaft (2).

WARNING

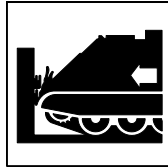

**Failure of control linkage can cause carrier to crash. Crash could kill or injure personnel.
Install NEW cotter pins, locknuts, and lock washers.**

3. Install new locknut (3) and washer (4) on left side of shaft (2).

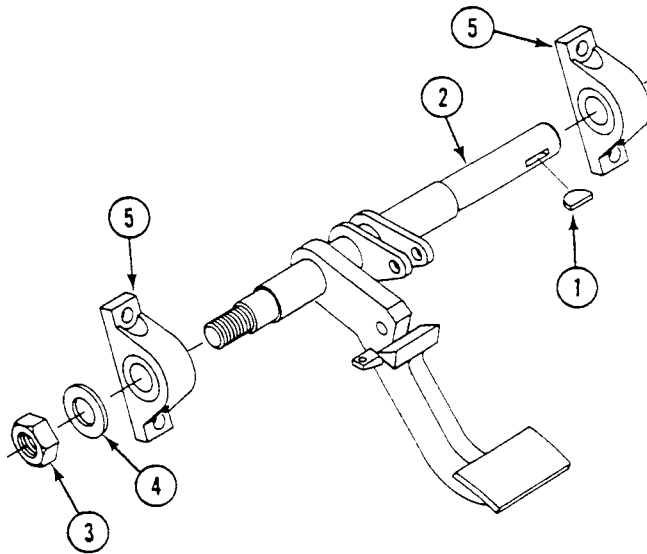

REPLACE UPPER AND LOWER SERVICE BRAKE PEDAL — Continued**0409 00**

4. Slide shaft (2) into driver's compartment bulkhead. Install new grommet (6) on shaft. Install grommet in bulkhead.
5. Install new key (1) on shaft (2).
6. (H) Install link (7) and washer (8) on shaft (2).
7. Install two mount bearings (5) on driver's compartment floor. Secure with four screws (9), washers (10), and new lockwashers (11).
8. (H) Secure link (7) to shaft (2) with new cotter pin (12).

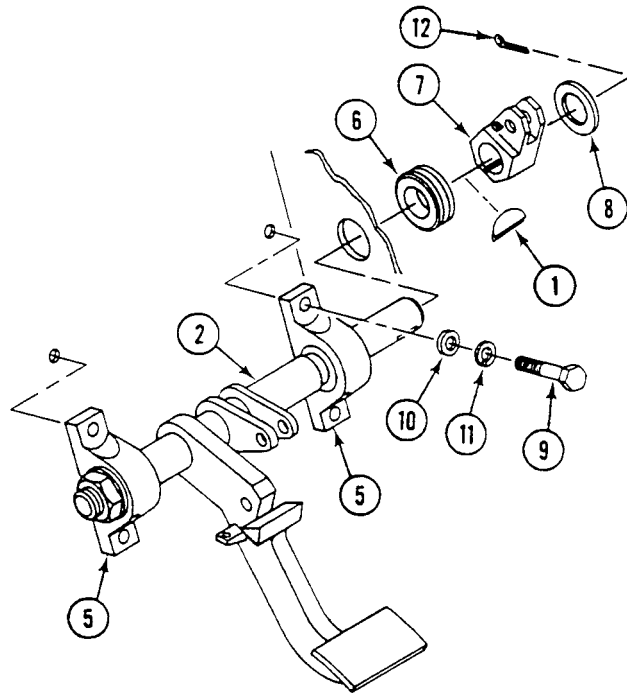

9. Install linkage rod (1) on cross-shaft link (2). Secure with new cotter pin (3), two washers (4), and clevis pin (5).
10. Install release spring (6) on link (2) and power plant bulkhead (7).
11. Install starter cannon plug (8) on power plant bulkhead (9).

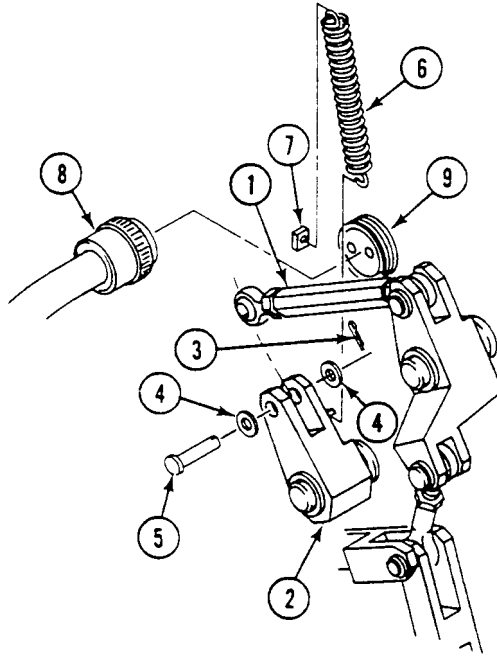

12. Install cable stop (10) on lower brake pedal lever (11) in driver's compartment. Secure with new cotter pin (12), two washers (13), and clevis pin (14).
13. Install upper brake pedal (15) on lower brake pedal (16). Secure with new cotter pin (17), two washers (18), and clevis pin (19).

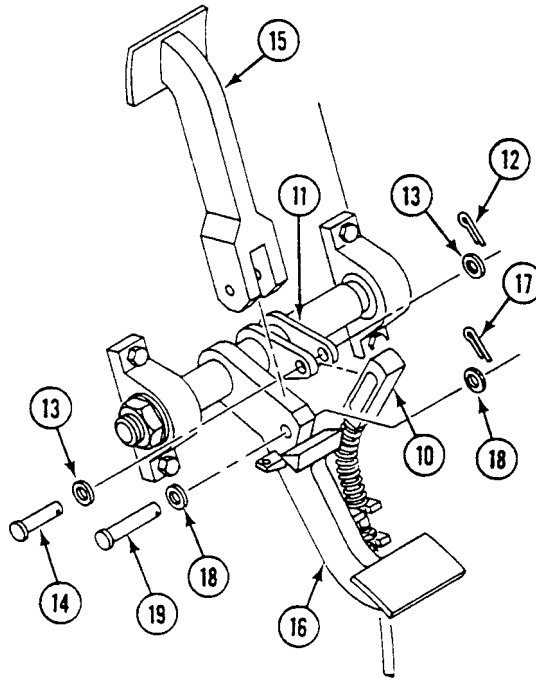

14. Pull upper brake pedal (15) to upper position. Install spring (20) on upper and lower brake pedals (15) and (16).

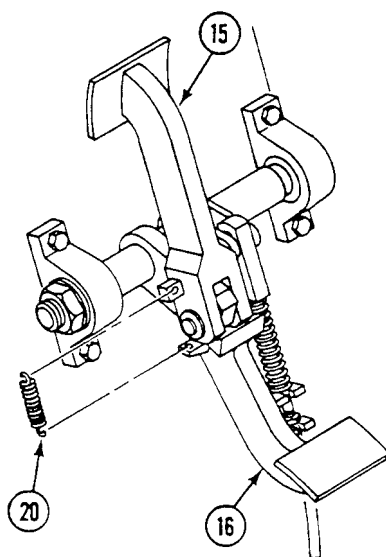

FOLLOW-THROUGH STEPS

1. Adjust service brake control linkage (WP 0407 00).
2. Install hull front access cover (WP 0449 00).
3. Install driver's power plant access panel (see your -10).
4. Close power plant front access door (see your -10).
5. Raise trim vane (see your -10).

END OF TASK

REPLACE SERVICE BRAKE CONTROL LINKAGE

0410 00

THIS WORK PACKAGE COVERS:

Removal (page 0410 00-2).
 Installation (page 0410 00-7).

INITIAL SETUP:

Maintenance Level

Unit

Personnel Required

Unit Mechanic

Helper (H)

Tools and Special Tools

General Mechanic's Tool Kit (WP 0926 00, Item 65)
 Crowfoot Attachment (WP 0926 00, Item 15)
 Vise (WP 0926 00, Item 68)
 Socket Wrench Set (WP 0926 00, Item 72)
 Torque Wrench (WP 0926 00, Item 85)

References

See your -10

Materials/Parts

Cotter pin
 Cotter pin (6)
 Key
 Locknut
 Lockwasher (2)

Equipment Condition

Engine stopped (see your -10)
 Carrier blocked (see your -10)
 Trim vane lowered (see your -10)
 Power plant front access door opened (see your -10)
 Hull front access cover removed (WP 0449 00)

REMOVAL

1. Remove two cotter pins (1), four washers (2), two clevis pins (3), and linkage rod (4) from cross-shaft link (5) and link (6). Discard two cotter pins.

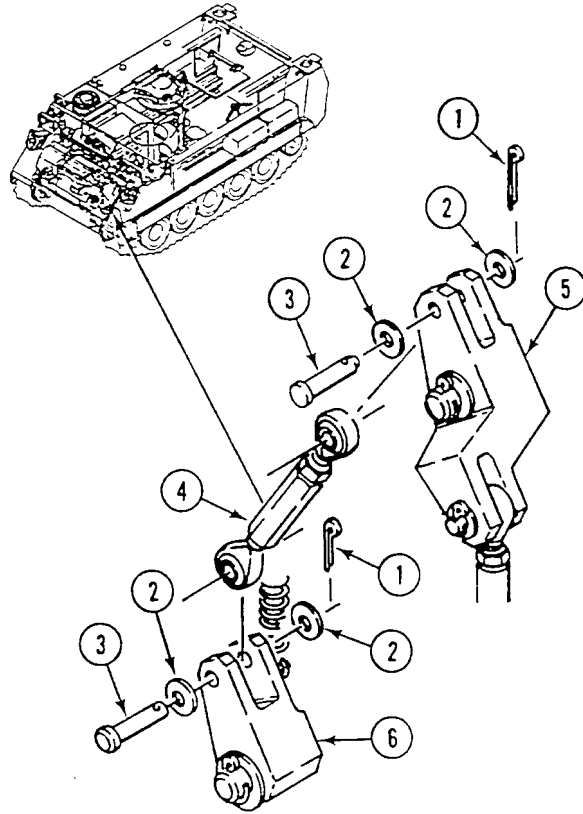

REPLACE SERVICE BRAKE CONTROL LINKAGE — Continued

0410 00

2. Remove screw (1), washer (2), and lockwasher (3) from brake arm (4) and left hand brake apply shaft (5). Discard lockwasher.
3. Remove screw (6), washer (7), and lockwasher (8) from brake arm (9) and right hand brake apply shaft (10). Discard lockwasher.

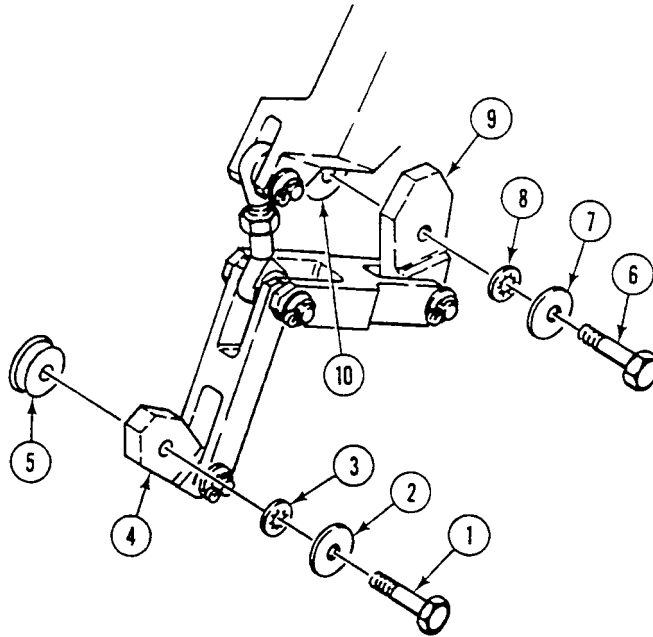

4. Remove clevis pin (11), cotter pin (12), two washers (13), and rod bearing (14) from cross-shaft link (15). Discard cotter pin.

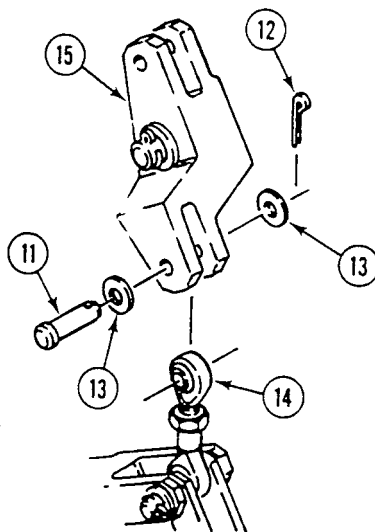

5. Remove hand brake arm and link assembly (16) from carrier.

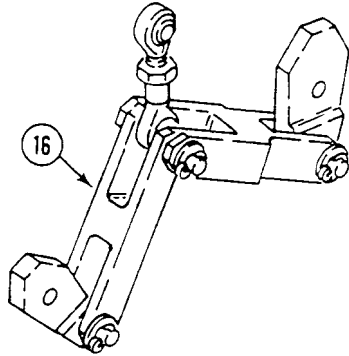

6. Remove cotter pin (17), two washers (18), clevis pin (19), and left hand brake arm (4) from link (20). Discard cotter pin.
7. Remove cotter pin (21), two washers (22), clevis pin (23), and right hand brake arm (9) from link (24). Discard cotter pin.

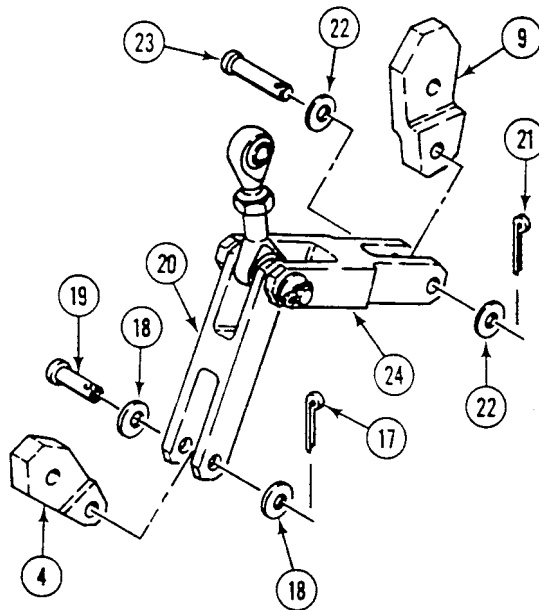

8. Remove cotter pin (1), two washers (2), clevis pin (3), and two links (4)(5) from rod (6). Discard cotter pin.

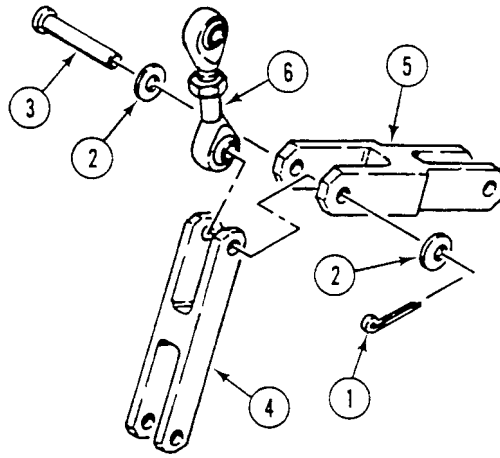

9. Remove four screws (7) and washers (8) from bearing unit and driver's compartment bulkhead. Remove shaft (9), journal bearing (10), and link (11) from hull. Have helper assist.

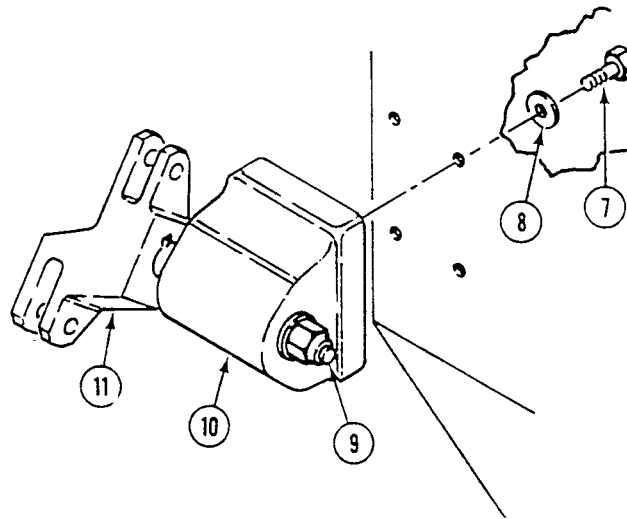

CAUTION

Take care not to damage parts when using vise.

10. Place link (11) in vise. Remove locknut (12) and washer (13) from shaft (9). Discard locknut.

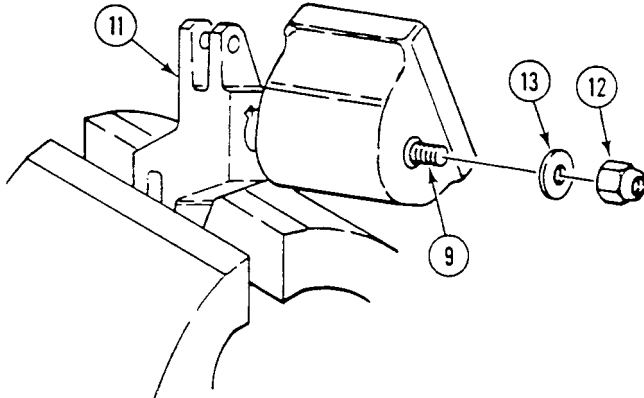

11. Take link (11) out of vise. Remove washer (14) and cotter pin (15) from shaft (9). Discard cotter pin.
12. Remove link (11) from shaft (9).
13. Remove key (16) from shaft (9). Discard key.
14. Remove journal bearing (10) from shaft (9).

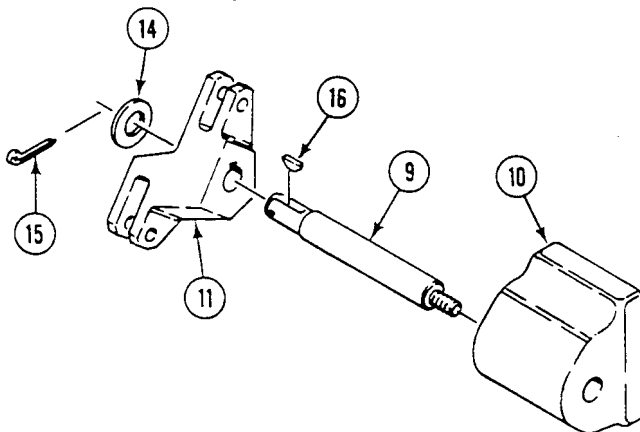

INSTALLATION

1. Install journal bearing (1) on shaft (2).
2. Install new key (3) in shaft (2).

WARNING

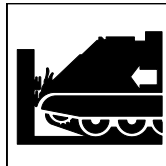

Failure of control linkage can cause carrier to crash. Crash could kill or injure personnel. Install new cotter pins and key.

3. Install link (4) on shaft (2). Secure with washer (5) and new cotter pin (6).

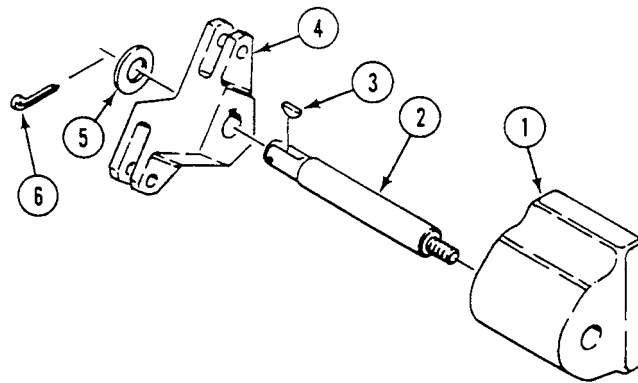

CAUTION

Take care not to damage parts when using vise.

4. Put link (4) in vise. Install washer (7) and new locknut (8) on right side of shaft (2).

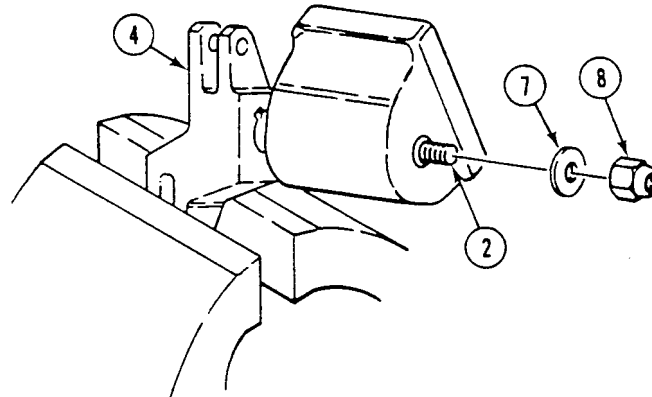

5. Install journal bearing (1) on hull. Secure with four screws (9), and washers (10). Have helper assist.

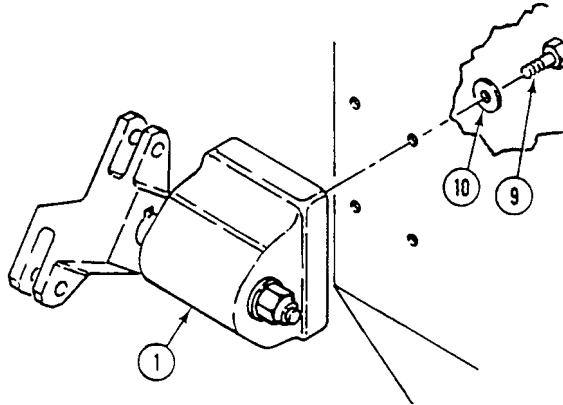

6. Install two links (11)(12) on rod (13). Secure with new cotter pin (14), two washers (15), and clevis pin (16).

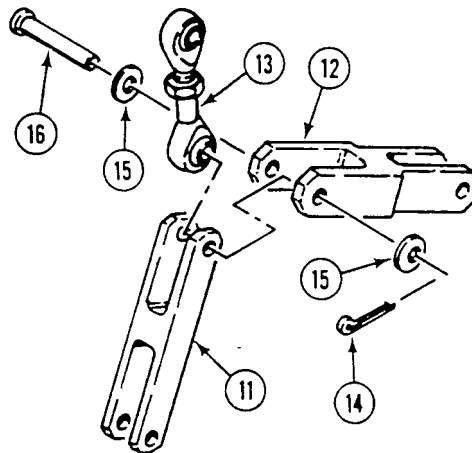

REPLACE SERVICE BRAKE CONTROL LINKAGE — Continued

0410 00

7. Install right hand brake arm (1) on link (2). Secure with new cotter pin (3), two washers (4), and clevis pin (5).
8. Install left hand brake arm (6) on link (7). Secure with new cotter pin (8), two washers (9), and clevis pin (10).

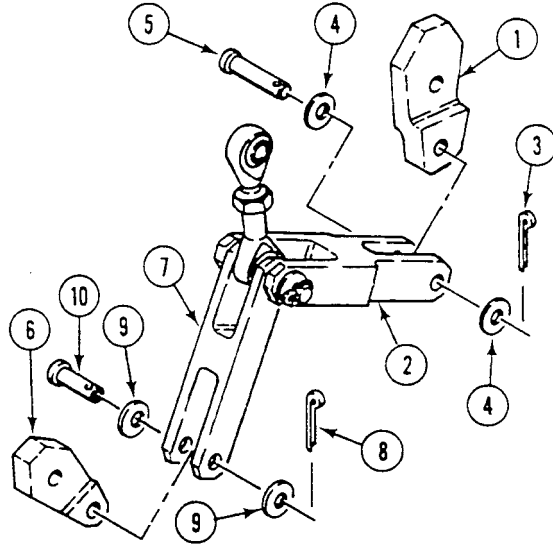

9. Install rod bearing (11) on cross-shaft link (12). Secure with clevis pin (13), new cotter pin (14), and two washers (15).

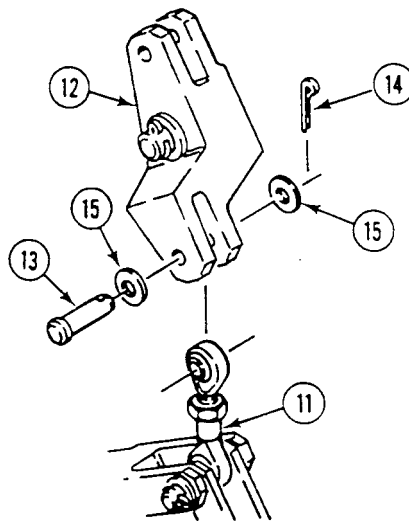

REPLACE SERVICE BRAKE CONTROL LINKAGE — Continued

0410 00

10. Install brake arm (1) on right hand apply shaft (16). Secure with screw (17), washer (18), and new lockwasher (19). TIGHTEN SCREW TO 25-27 LB-FT (34-37 N·m) TORQUE.
11. Install brake arm (6) on left hand apply shaft (20). Secure with screw (21), washer (22), and new lockwasher (23). TIGHTEN SCREW TO 25-27 LB-FT (34-37 N·m) TORQUE.

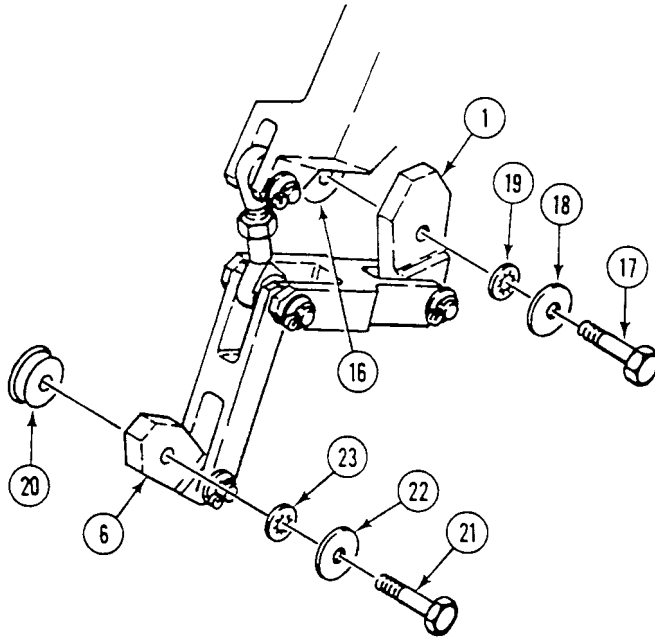

12. Install linkage rod (1) on cross-shaft link (2) and link (3). Secure with two new cotter pins (4), four washers (5), and two clevis pins (6).

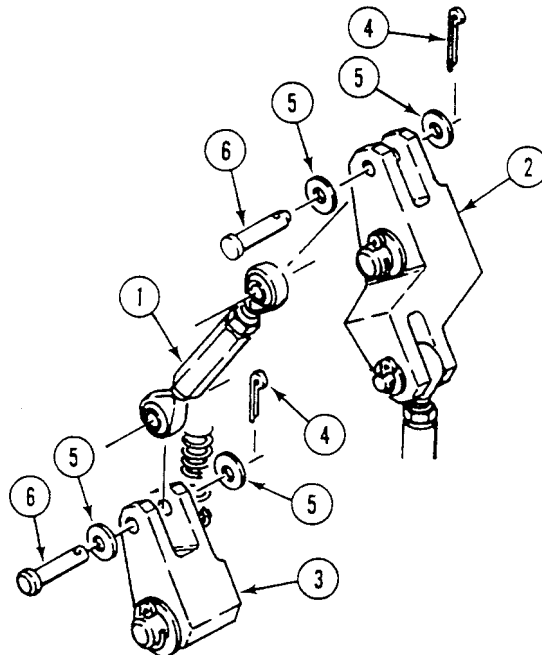

FOLLOW-THROUGH STEPS

WARNING

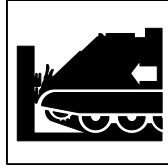

Failure of brake control linkage can cause carrier to crash. Crash could kill or injure personnel. Adjust service brake control linkage and install new cotter pin.

1. Adjust service brake control linkage (WP 0407 00).
2. Install hull front access cover (page 0449 00-2).
3. Close power plant front access door (see your -10).
4. Raise trim vane (see your -10).

END OF TASK

REPLACE PARKING BRAKE CONTROL CABLE ASSEMBLY

0411 00

THIS WORK PACKAGE COVERS:

Removal (page 0411 00-1).
 Installation (page 0411 00-4).

INITIAL SETUP:

Maintenance Level

Unit

References

See your -10

Tools and Special Tools

General Mechanic's Tool Kit (WP 0926 00, Item 65)

Equipment Condition

Engine stopped (see your -10)
 Carrier blocked (see your -10)
 Trim vane lowered (see your -10)
 Hull front access cover removed (WP 0449 00)

Materials/Parts

Cotter pin
 Cotter pin
 Locknut (2)
 Locknut (4)

Personnel Required

Unit Mechanic
 Helper (H)

REMOVAL

1. Push parking brake lever (1) down into OFF position.
2. Remove cotter pin (2), washer (3), and clevis pin (4) from cable clevis (5) and lever link (6). Disconnect link from cable. Discard cotter pin.

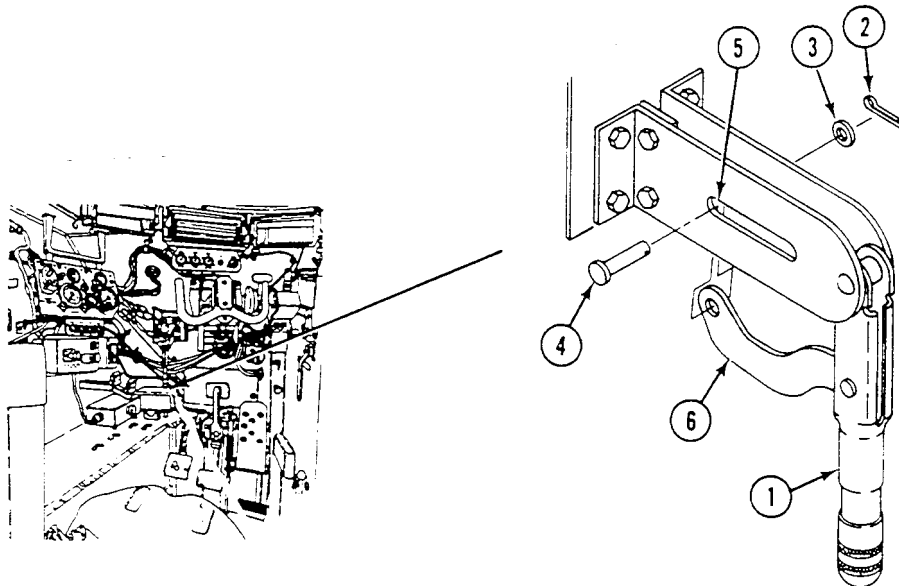

- Remove four screws (1), eight washers (2), and four locknuts (3) from mounting bracket (4). Remove lever (5) from bracket. Discard locknuts.

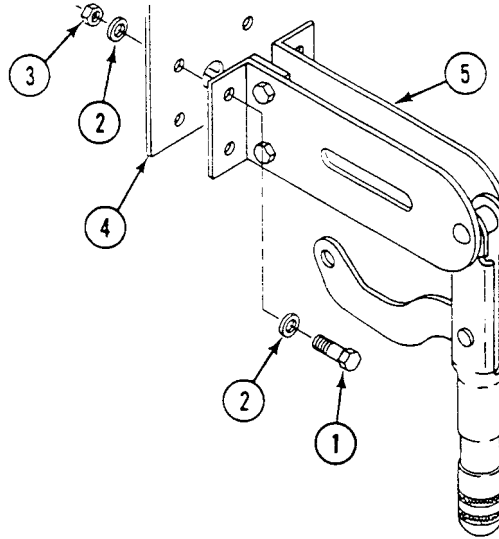

- Remove two screws (6), washers (7), locknuts (8), cable (9), spacer (10), and clamp (11) from lever (5). Discard locknuts.

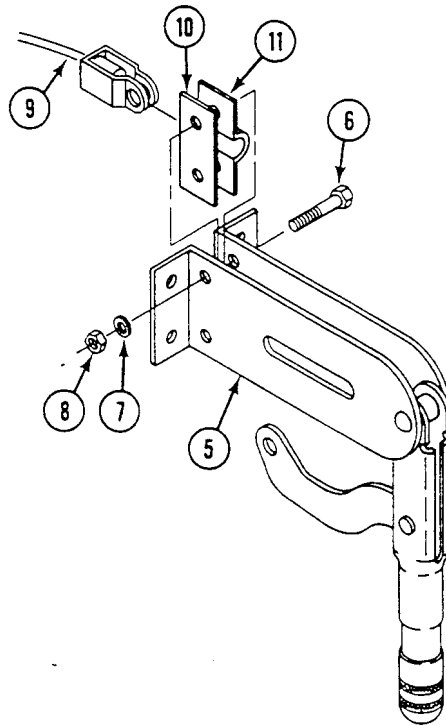

REPLACE PARKING BRAKE CONTROL CABLE ASSEMBLY — Continued

0411 00

5. Remove cotter pin (12), two washers (13), and clevis pin (14) from cable stop (15) and lower brake pedal lever link (16). Discard cotter pin.
6. Loosen jam nut (17) under cable stop (15) on cable (18). Remove cable stop, washer (19), jam nut, and spring (20) from cable.

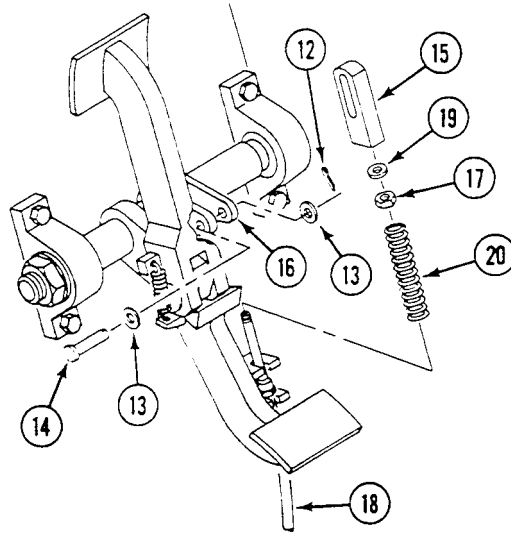

7. Remove top jam nut (21) from cable (18). Remove cable from mounting bracket (22).
8. Remove jam nut (23) from cable (18).

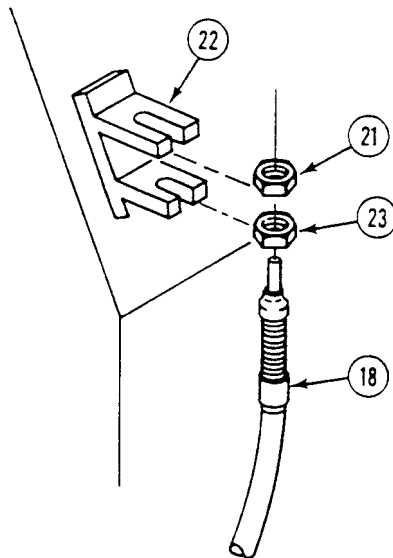

9. Remove screw (1), washer (2), clamp (3), cable (4), and two grommets (5) and (6) from carrier through power plant front access. Have helper assist.

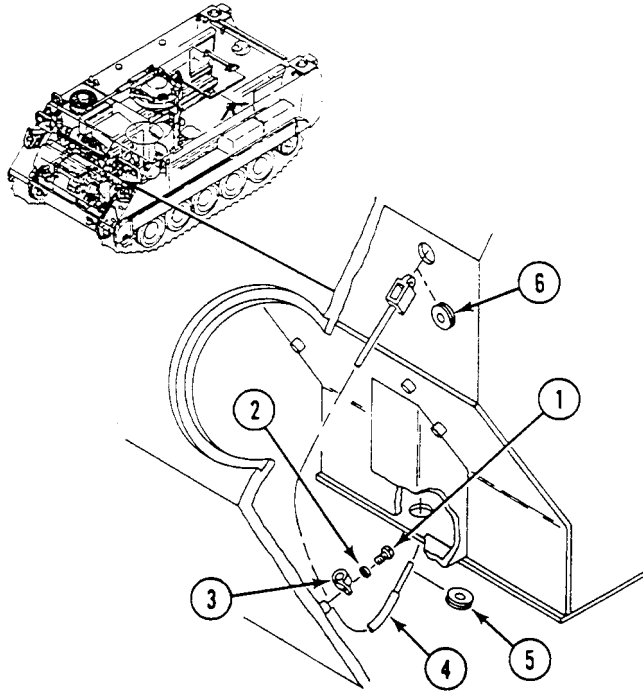

INSTALLATION

1. Install grommet (7) on threaded end of cable (8). Route cable through driver's compartment floor plate access hole. Install grommet in access hole. Have helper assist.
2. Install grommet (9) on cable (8). Route cable clevis (10) through hole in driver's compartment bulkhead. Install grommet in hole. Have helper assist.

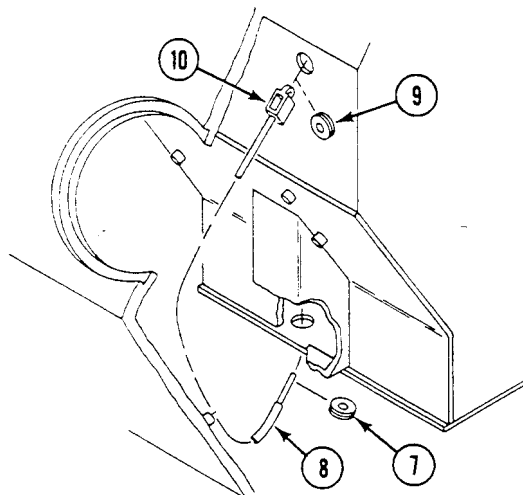

3. Install jam nut (11) on cable (8).
4. Install cable (8) in hole of lower mounting bracket (12) with jam nut (11) under lower bracket.
5. Install second jam nut (13) on cable (8). Thread jam nut on cable until tight against lower mounting bracket (12).

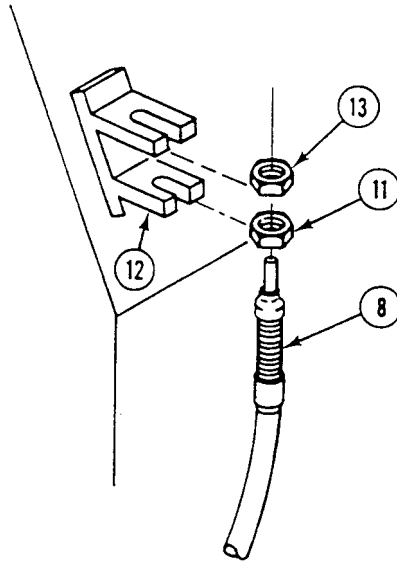

6. Install cable (1) in hole of upper mounting bracket (2).
7. Install spring (3), third jam nut (4) and washer (5) on cable (1). Install brake stop (6) on cable end. Allow 3/4 inch (1.9 cm) minimum thread engagement into brake stop (6).

WARNING

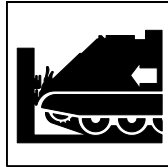

**Failure of control linkage can cause carrier to crash. Crash could kill or injure personnel.
Install new cotter pins and locknuts.**

8. Install brake stop (6) on lower brake pedal lever link (7). Secure with clevis pin (8), two washers (9), and new cotter pin (10).

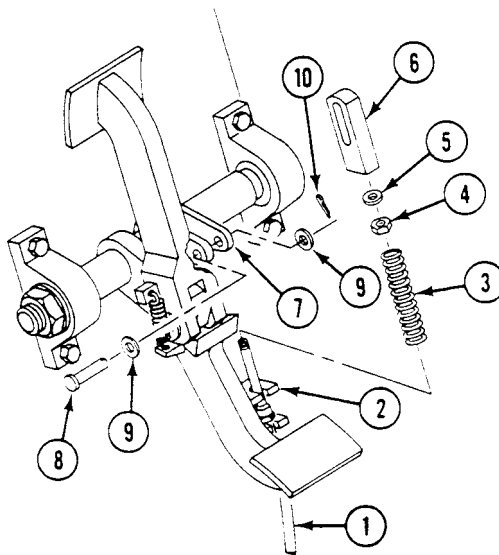

9. Install cable clevis (11) in link of parking brake lever (12). Secure with clevis pin (13), washer (14), and new cotter pin (15).

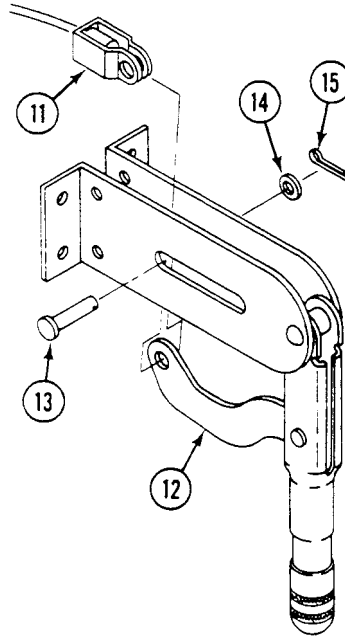

10. Install cable (1), spacer (16), and clamp (17) on lever (18). Secure with two screws (19), washers (20), and new locknuts (21).

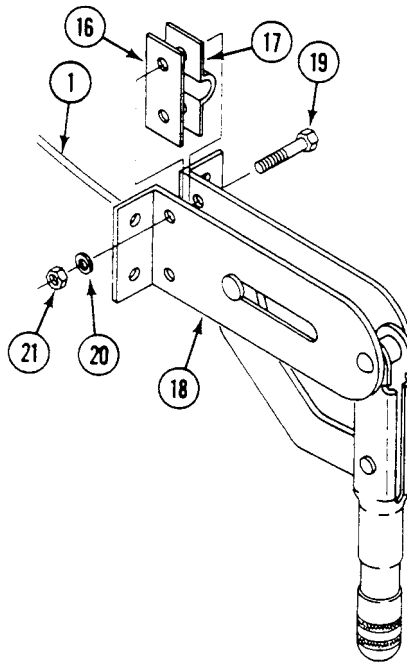

11. Install lever (1) on mounting bracket (2). Secure with four screws (3), eight washers (4), and four new locknuts (5).

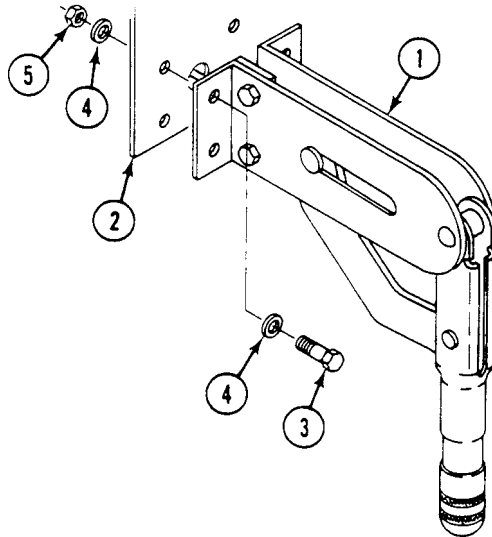

12. Install clamp (6) on cable (7). Secure clamp to front plate of hull (8) with screw (9) and washer (10).

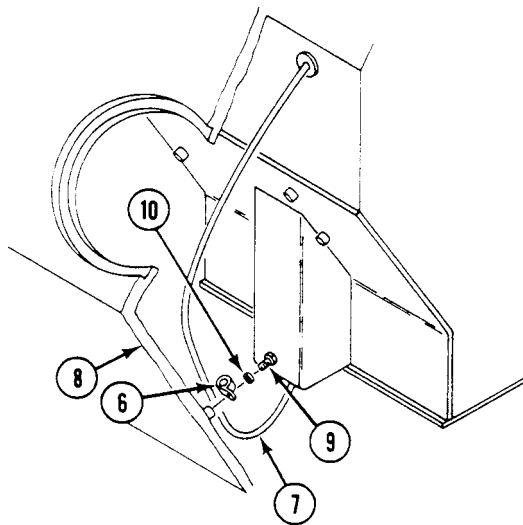

FOLLOW-THROUGH STEPS

1. Adjust parking brake (WP 0408 00).
2. Install hull front access cover (WP 0449 00).
3. Raise trim vane (see your -10).

END OF TASK

REPLACE PARKING BRAKE CONTROL LEVER ASSEMBLY

0412 00

THIS WORK PACKAGE COVERS:

Removal)page 0412 00-1).
 Installation)page 0412 00-3).

INITIAL SETUP:

Maintenance Level

Unit

Personnel Required

Unit Mechanic

Tools and Special Tools

General Mechanic's Tool Kit (WP 0926 00, Item 65)

References

See your -10

Materials/Parts

Cotter pin
 Locknut (4)
 Locknut (2)

Equipment Condition

Engine stopped (see your -10)
 Carrier blocked (see your -10)

REMOVAL

1. Place parking brake lever assembly in off position by pushing brake lever handle (1) down.

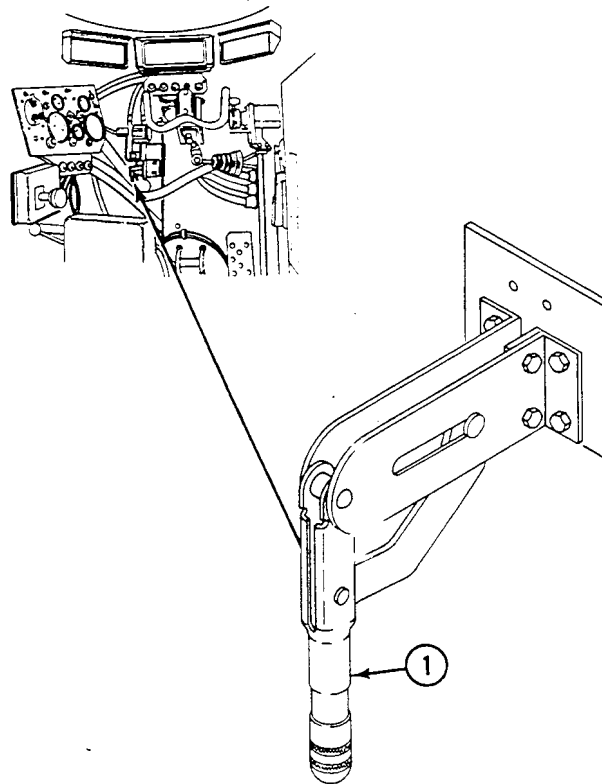

REPLACE PARKING BRAKE CONTROL LEVER ASSEMBLY — Continued

0412 00

2. Remove cotter pin (2), washer (3), and clevis pin (4) from cable clevis (5) and lever link (6). Disconnect link from cable. Discard cotter pin.

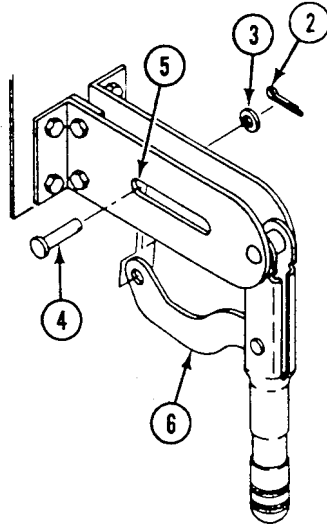

3. Remove four locknuts (1), screws (2), and washers (3) from parking brake lever (4) and mounting bracket (5). Remove parking brake lever from mounting bracket. Discard locknuts.
4. Remove two locknuts (6) and screws (7) from parking brake control cable conduit (8), spacer (9), and clamp (10). Remove cable spacer and clamp from brake lever assembly (4). Discard locknuts.

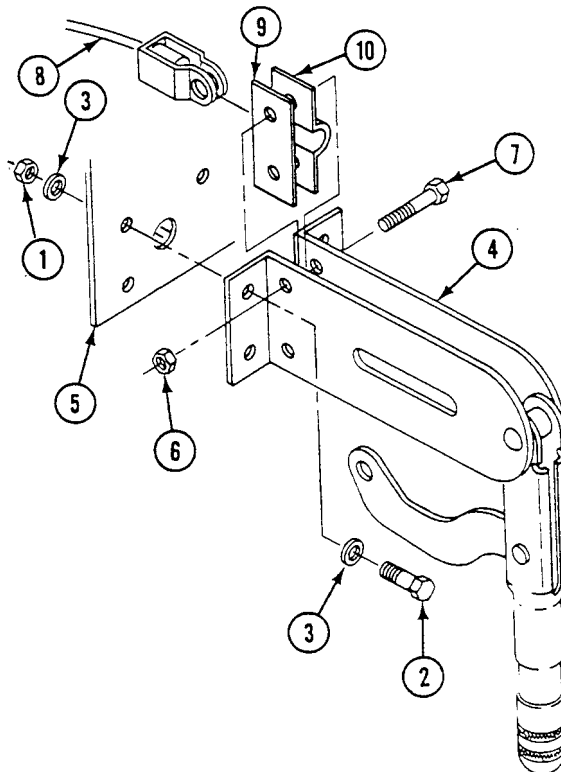

INSTALLATION

1. Install parking brake control cable conduit (8), spacer (9), and clamp (10) on parking brake lever assembly (4). Secure with two screws (7) and new locknuts (6).
2. Install parking brake lever (4) on mounting bracket (5). Secure with four screws (2), eight washers (3), and four new locknuts (1).

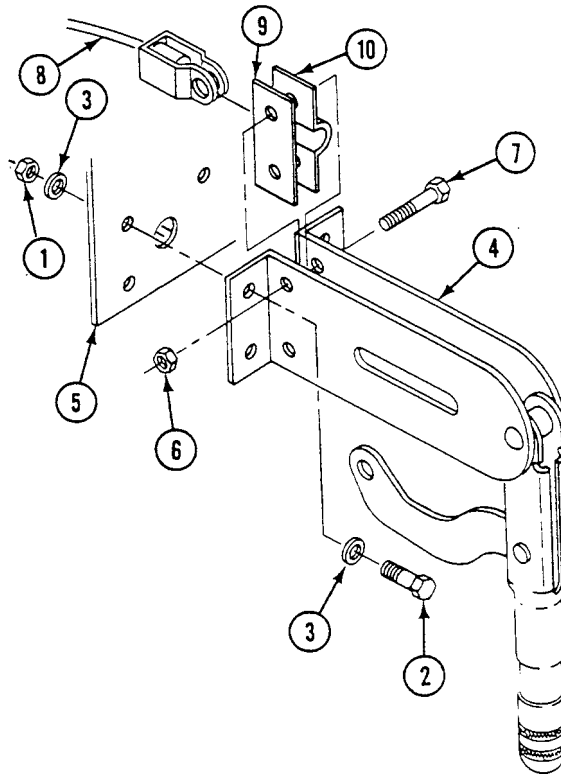

REPLACE PARKING BRAKE CONTROL LEVER ASSEMBLY — Continued

0412 00

3. Install cable clevis (11) in link of parking brake lever (12). Secure with clevis pin (13), washer (14), and new cotter pin (15).

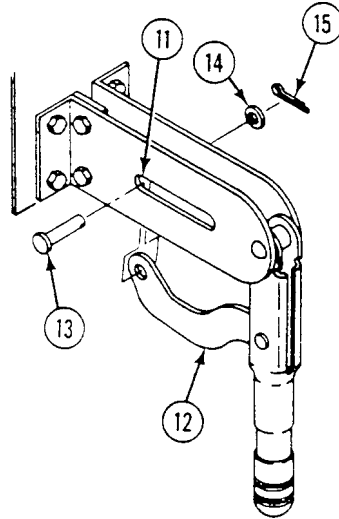
**FOLLOW-THROUGH STEPS**

1. Adjust parking brake (WP 0408 00).

END OF TASK

INDEX

<u>Subject</u>	<u>WP Sequence No.-Page No.</u>
5.0 KW Auxiliary Power Unit M577A3 and M1068A3 Replacement.....	0675 00-1
A	
A.C. Power Extension Box A7 (M1068A3) Replace.....	0815 00-1
A1 Power Control Enclosure Assembly M1068A3 Replacement.....	0826 00-1
A4 Power Entry Box Assembly M1068A3 Replacement.....	0832 00-1
AC Cable Assembly W252 M1068A3 Replacement.....	0857 00-1
AC Light Cable (W11) M1068A3 Replacement.....	0845 00-1
AC Power Extension Box A19 M1068A3 Replacement.....	0822 00-1
AC Power Extension Box A6 M1068A3 Replacement.....	0834 00-1
AC Power Extension Box A6 and DC Power Extension Box A9 and Mount M1068A3 Replacement.....	0834 00-1
AC Power Extension Cable (W7) M1068A3 Replacement.....	0842 00-1
AC Power Extension Cable (W8) (M1068A3) Replace.....	0843 00-1
Accelerator Linkage Adjust.....	0214 00-1
Accelerator Pedal Lower Replacement.....	0215 00-1

INDEX, cont'd

<u>Subject</u>	<u>WP Sequence No.-Page No.</u>
Accelerator Pedal Assembly	
Upper	
Replacement.....	0216 00-1
Access cover	
Battery box	
M577A3 and M1068A3	
Repair.....	0352 00-1
Fan drive pulley	
Removal/installation.....	0440 00-1
Hull front	
Replacement.....	0449 00-1
Power plant bottom	
Replacement.....	0450 00-1
Access Covers	
Fuel Tank	
M577A3 and M1068A3	
Replacement.....	0188 00-1
Access covers	
Fuel tank	
All except M577A3 and M1068A3	
Replacement.....	0187 00-1
Access door	
Radiator	
Replacement.....	0469 00-1
Turbine	
M58	
Replacement.....	0485 00-1
Access door gasket	
Turbine	
M58	
Replacement.....	0486 00-1
Access door hinges	
Turbine	
M58	
Replacement.....	0487 00-1
Access panel	
Driver's power plant	
Replacement.....	0441 00-1
Access Plate	
Adapter	
Smoke Generator (M1059A3)	
Replace.....	0766 00-1

INDEX, cont'd

<u>Subject</u>	<u>WP Sequence No.-Page No.</u>
Adapter	
Speedometer	
Replace.....	0860 00-1
Tachometer	
Replace.....	0863 00-1
Adjuster	
Track tension	
Replacement.....	0419 00-1
Admittance buzzer and switch	
M577A3 and M1068A3	
Replacement.....	0334 00-1
Air Box Heater	
IgnitionWire	
Replacement.....	0204 00-1
Wiring Harness	
Replacement.....	0205 00-1
Air Box Heater Lower Fuel Line	
Replacement.....	0206 00-1
Air Box Ignition Coil	
Replacement.....	0208 00-1
Air box pressure transducer	
Replacement.....	0327 00-1
Air Cleaner	
Elbow	
Replacement.....	0168 00-1
Filter Element	
Service.....	0167 00-1
Replacement.....	0168 00-1
Air cleaner	
Restriction indicator	
Replace.....	0171 00-1
Restriction indicator hose	
Replace.....	0172 00-1
Air Cleaner Assembly	
Replace	0169 00-1
Air Cleaner Retainer	
Repair	0170 00-1
Air Compressor	
Electrical Cable Assembly	
M1059A3	
Replacement.....	0758 00-1

INDEX, cont'd

<u>Subject</u>	<u>WP Sequence No.-Page No.</u>
Air Compressor Assembly (M1059A3 Only)	
Replace.....	0762 00-1
Air Hose	
Adapter Access Plate to Cover Assembly Smoke Generator (M1059A3)	
Replace.....	0768 00-1
Compressor Reservoir to Access Plate Smoke Generator (M1059A3)	
Replace.....	0767 00-1
Air intake	
Elbow	
Replace.....	0173 00-1
Air Intake and Exhaust Pipes	
Heater	
Replacement.....	0683 00-1
Air Intake elbow and hose	
Grill	
Replace.....	0174 00-1
Air Intake Pipes, Heater	
All Except M1064A3	
Replacement.....	0682 00-1
Air Purifier and Frame	
NBC	
M58	
Replacement.....	0914 00-1
Air purifier and frame	
M13	
M1068A3 only	
Replace.....	0779 00-1
Air Separator	
Coolant	
Replacement.....	0236 00-1
Air ventilator	
Rear compartment	
Replacement.....	0454 00-1
Alarm Kit, Automatic	
Chemical Agent	
M113A3	
Installation/Removal	0918 00-1

INDEX, cont'd

<u>Subject</u>	<u>WP Sequence No.-Page No.</u>
Ammunition Rack	
Horizontal	
M1064A3	
Replacement.....	0606 00-1
Ammunition rack	
Horizontal	
M1064A3	
Repair.....	0607 00-1
Vertical	
M1064A3	
Replacement.....	0608 00-1
Amplifier	
Intercom	
M58	
Replace.....	0888 00-1
AN/VAS-5 Driver's Night Vision Enhancer Sensor Set Assembly Adapter (DVE)	
M58	
Replacement.....	0866 05-1
AN/VAS-5 Driver's Vision Enhancer Stowage Bracket	
M58	
Replacement.....	0866 03-1
AN/VVS-2	
Driver's Night Vision Stowage	
All Except M58	
Replacement.....	0572 00-1
AN/VVS-2 driver's night vision guard	
Driver's Hatch	
All Except M58	
Replacement.....	0536 00-1
(AN/VVS-2) Driver's night vision mount	
All Except M58	
Replacement.....	0537 00-1
Anchor	
Torsion bar	
Replacement.....	0414 00-1
Antenna	
AS3916/VRC	
M58	
Replacement.....	0887 00-1
Guard	
Replacement.....	0575 00-1

INDEX, cont'd

<u>Subject</u>	<u>WP Sequence No.-Page No.</u>
Mast Bracket Assembly	
M1068A3	
Repair.....	0625 00-1
Replacement.....	0625 00-1
Support	
M58	
Replacement.....	0602 00-1
APIU Rack	
Mount and Bracket	
M1068A3	
Replacement.....	0813 00-1
Arm	
Road wheel support	
Replacement.....	0415 00-1
Arm assembly	
Idler wheel	
Replacement.....	0417 00-1
Armor	
Front	
M113A3	
Replacement.....	0749 00-1
Shields, Commander's Cupola	
M113A3 and M1064A3	
Replacement.....	0747 00-1
Smoke Generator (M1059A3)	
Replace.....	0771 00-1
Armor Kit	
M113A3	
Installation.....	0748 00-1
Mine	
M113A3	
Installation/Removal.....	0752 00-1
Armor plate	
Left front	
Replacement.....	0447 00-1
Right front	
Replacement.....	0448 00-1
AS3916/VRC Antenna	
M58	
Replacement.....	0887 00-1

INDEX, cont'd

<u>Subject</u>	<u>WP Sequence No.-Page No.</u>
Assembly	
M8A3/M14 Orifice connector	
M113A3, M1059A3, and M577A3 only	
Replace.....	0780 00-1
Auxiliary power (slave) receptacle	
M113A3, M1059A3, M1064A3, and M58 only	
Replacement.....	0263 00-1 ■
Auxiliary power (slave) receptacle ground lead	
M113A3, M1059A3, M1064A3, and M58	
Replacement.....	0379 00-1 ■
Auxiliary Power Unit	
5.0 KW	
M577A3 and M1068A3	
Replacement.....	0675 00-1
Auxiliary Power Unit Fuel Shutoff Valve	
M577A3 and M1068A3	
Replacement.....	0676 00-1
Auxiliary Power Unit Valve-to-bulkhead Fuel Supply Hoses	
M577A3 and M1068A3	
Replacement.....	0677 00-1
Auxiliary Tank	
Replacement.....	0230 00-1
Auxiliary tank fluid level detector	
Replacement.....	0329 00-1
Azimuth lock	
Commander's cupola	
M113A3, M1059A3, M58, and M1064A3	
Replacement.....	0489 00-1
B	
Back Assembly	
Driver's Seat	
Repair.....	0554 00-1
Replacement.....	0553 00-1
Balance Hose	
Replacement.....	0234 00-1
Base	
Smoke grenade launcher	
M113A3 and M1059A3 only	
Replacement.....	0455 00-1 ■
Base Extension	
Right Side	
M1068A3	
Replacement.....	0623 00-1

INDEX, cont'd

<u>Subject</u>	<u>WP Sequence No.-Page No.</u>
Base Extension Supports	
Right Side	
M1068A3	
Replacement.....	0624 00-1
Batteries and battery box	
M58	
Replacement.....	0348 00-1
Batteries and retainers	
M113A3 and M1059A3	
Replacement.....	0346 00-1
M577A3 and M1068A3	
Replacement.....	0347 00-1
Battery	
Box	
M577A3 and M1068A3	
Repair.....	0351 00-1
M1064A3	
Replacement.....	0349 00-1
Retainers	
M1064A3	
Replacement.....	0349 00-1
Battery box	
M113A3 and M1059A3	
Repair.....	0350 00-1
Battery box (right side)	
M1064A3	
Repair.....	0354 00-1
Battery box access cover	
M577A3 and M1068A3	
Repair.....	0352 00-1
Battery box hose	
Engine to	
Replacement.....	0714 00-1
Battery Box Insulation and Heat Exchanger	
Replacement.....	0718 00-1
Battery box vent fitting	
M58	
Replacement.....	0355 00-1
Battery drawer	
M1064A3	
Repair.....	0353 00-1

INDEX, cont'd

<u>Subject</u>	<u>WP Sequence No.-Page No.</u>
Battery Drawer Insulation and Heat Exchanger	
M1064A3	
Replacement.....	0719 00-1
Battery ground lead	
M577A3 and M1068A3	
Connect	0338 00-1
Disconnect.....	0338 00-1
Battery ground strap	
M113A3, M1059A3, M1064A3, and M58	
Connect	0337 00-1
Disconnect.....	0337 00-1
Battery leads and terminals	
M113A3 and M1059A3	
Replacement.....	0340 00-1
M577A3 and M1068A3	
Replacement.....	0341 00-1
M58	
Replacement.....	0345 00-1
Battery leads and terminals (left side)	
M1064A3	
Replacement.....	0343 00-1
Battery leads and terminals (right side)	
M1064A3	
Replacement.....	0344 00-1
Battery Plate to Battery Plate Hose	
Replacement.....	0722 00-1
Battery to master switch lead (circuit 6)	
M1064A3	
Replacement.....	0358 00-1
M113A3 and M1059A 3	
Replacement.....	0356 00-1
M577A3 and M1068A3	
Replacement.....	0357 00-1
Battery-to-radio Wiring harness	
(Left Side)	
M113A3 and M1059A3	
Replacement.....	0369 00-1
Battery-to-radio wiring harness (right side)	
M113A3	
Replacement.....	0370 00-1
Battery/generator indicator malfunctions	0051 00-1

INDEX, cont'd

<u>Subject</u>	<u>WP Sequence No.-Page No.</u>
Bearing	
Tow Start Control Assembly	
Replacement.....	0391 00-1
Bearings	
Idler wheel arm	
Replacement.....	0418 00-1
Road wheel support	
Replacement.....	0415 00-1
Belt	
Generator drive	
Adjustment.....	0252 00-1
Replacement.....	0253 00-1
Ventilating Fan Drive	
Adjustment.....	0242 00-1
Replacement.....	0243 00-1
Belts	
Coolant Pump	
Adjustment.....	0239 00-1
Coolant Pump Idler	
Replacement.....	0240 00-1
Personnel	
M113A3	
Replacement.....	0546 00-1
M577A3	
Replacement.....	0547 00-1
Personnel seat	
M1059A3	
Replacement.....	0549 00-1
M1064A3	
Replacement.....	0550 00-1
Bilge Pump	
Front	
Replace.....	0632 00-1
Pipes	
Front, Replace.....	0631 00-1
Rear	
Replacement.....	0635 00-1
Bilge pump circuit breakers	
Replacement.....	0275 00-1
Bilge Pump Pipes	
Rear Bilge	
Replacement.....	0634 00-1

INDEX, cont'd

<u>Subject</u>	<u>WP Sequence No.-Page No.</u>
Blackout Curtain	
M577A3 and M1068A3	
Replacement.....	0629 00-1
Blackout dome lights do not work	
M1068A3 only	0041 00-1
Blackout drive light doesn't work.....	0030 00-1
Blackout headlight	
Repair	0306 00-1
Replacement.....	0305 00-1
Blackout marker light	
Repair	0308 00-1
Replacement.....	0307 00-1
Blackout marker light(s) don't work	0034 00-1
Blank display diagnostic troubleshooting	
STE/ICE	0138 00-1
Blower switch	
M577A3 and M1068A3 only	
Replacement.....	0278 00-1
Bottom access cover	
Power plant	
Replacement.....	0450 00-1
Box	
Battery	
M113A3 and M1059A3	
Repair.....	0350 00-1
Heater Control	
Coolant Heater	
Repair.....	0737 00-1
Repalcement.....	0736 00-1
Personnel Heater Control	
Repair	0702 00-1
Replacement.....	0701 00-1
Box Assembly A5	
Tent Interface Panel	
M1068A3	
Replacement.....	0833 00-1
Bracket	
Chemical Alarm Refill Tray	
M113A3	
Replacement.....	0922 00-1
Coolant Heater and Pump	
Replacement.....	0732 00-1

INDEX, cont'd

<u>Subject</u>	<u>WP Sequence No.-Page No.</u>
Generator	
Replacement.....	0255 00-1
M13 Orifice	
M1068A3 only	
Replace.....	0781 00-1
Oil Can	
Replacement.....	0574 00-1
Parking brake	
Replacement.....	0331 00-1
Power Extension Box A18	
M1068A3	
Replacement.....	0836 00-1
Ramp	
M113A3, M577A3, and M1068A3	
Replacement.....	0516 00-1
Ramp Door Stop	
Replacement.....	0517 00-1
Roadside Data Panel Assembly A13	
M1068A3	
Replacement.....	0835 00-1
Spare Battery, Chemical Alarm	
M113A3	
Replace/Repair.....	0921 00-1
Transmission range controller	
Used with cable-activated steering lock	
Replacement.....	0387 00-1
Used with solenoid-activated steering lock	
Replacement.....	0386 00-1
Bracket,	
Mortar Base Stowage	
M1064A3	
Replacement.....	0615 00-1
Windshield Stowage	
M1064A3	
Replacement.....	0614 00-1
Brackets	
Rifle	
Replacement.....	0573 00-1
Brackets and Mounts	
Right Equipment Rack	
M1068A3	
Replacement.....	0814 00-1

INDEX, cont'd

<u>Subject</u>	<u>WP Sequence No.-Page No.</u>
Brake	
Parking	
Adjustment.....	0408 00-1
Brake adjustment	
Transmission	
Check	0406 00-1
Brake assembly	
Commander's cupola	
M113A3, M1059A3, M58, and M1064A3	
Replacement.....	0492 00-1
Brakes	
Transmission	
Adjust.....	0394 00-1
Breather Hose	
Ramp Cylinder	
All Except M1064A3	
Replacement.....	0666 00-1
M1064A3	
Replacement.....	0667 00-1
Bulkhead Connection Hose	
Fuel Pump to	
M113A3, M1059A3, and M58	
Replacement.....	0691 00-1
Bulkhead connection to Personnel Heater Tube	
M577A3 and M1068A3	
Replacement.....	0687 00-1
Bumper	
Driver's Hatch	
M113A3, M1059A3, M1064A3, and M58	
Replacement.....	0532 00-1
Buzzer and switch	
Admittance	
M577A3 and M1068A3	
Replacement.....	0334 00-1
Bypass plug	
Differential	
Replacement.....	0401 00-1
C	
Cable	
Adapter	
M1068A3	
Replacement.....	0849 00-1, 0850 00-1

INDEX, cont'd

<u>Subject</u>	<u>WP Sequence No.-Page No.</u>
Artillery Communication Inside	
M577A3	
Replacement.....	0746 00-1
Commander's Intercommunication Set	
M58	
Replacement.....	0893 00-1
Driver's Intercommunication Set	
M58	
Replacement.....	0892 00-1
Instrument panel special purpose	
Replacement.....	0290 00-1
Operator's Intercommunication Set	
M58	
Replacement.....	0894 00-1
Reel holder	
M1064A3	
Replacement.....	0603 00-1
Speedometer	
Repair.....	0861 00-1
Replace.....	0860 00-1
Service.....	0858 00-1
Tachometer	
Repair.....	0865 00-1
Replace.....	0864 00-1
Service.....	0858 00-1
W251	
M1068A3	
Replacement.....	0852 00-1
W252	
M1068A3	
Replacement.....	0857 00-1
W28	
M1068A3	
Replacement.....	0849 00-1
W29	
M1068A3	
Replacement.....	0850 00-1
W35	
M1068A3	
Replacement.....	0849 00-1
W38	
M1068A3	
Replacement.....	0850 00-1

INDEX, cont'd

<u>Subject</u>	<u>WP Sequence No.-Page No.</u>
W42	
M1068A3	
Replacement.....	0852 00-1
W43	
M1068A3	
Replacement.....	0852 00-1
Cable (W10)	
DC Power Extension	
M1068A3	
Replace.....	0844 00-1
Cable (W11)	
AC Light	
M1068A3	
Replacement.....	0845 00-1
Cable (W4)	
DC Battery	
M1068A3	
Replacement.....	0838 00-1
Cable (W40)	
Single Point LAN	
M1068A3	
Replacement.....	0851 00-1
Cable (W5)	
Inverter AC	
Replacement/Repair	0839 00-1
Cable (W6)	
Inverter DC	
M1068A3	
Replacement.....	0840 00-1
Cable (W7)	
AC Power Extension	
M1068A3	
Replacement.....	0842 00-1
Cable (W8)	
AC Power Extension (M1068A3)	
Replace.....	0843 00-1
Cable Assembly	
Control	
Tow Start	
Adjustment.....	0390 00-1
Smoke Generator Internal	
M1059A3	
Replacement.....	0760 00-1

INDEX, cont'd

<u>Subject</u>	<u>WP Sequence No.-Page No.</u>
Cable assembly	
Driver's night vision (DNV) (AN/VVS-2) power supply	
All Except M58	
Replacement.....	0368 00-1
Cable Assembly (W4/W6)	
M1068A3	
Repair	0841 00-1
Cable reel holder assembly	
M1064A3	
Repair	0604 00-1
Cable Tube	
External	
Replacement.....	0905 00-1
Cable W3	
Power Distribution	
M1068A3	
Replacement.....	0837 00-1
Cable-activated steering lock malfunctions.....	0077 00-1
Cables	
LAN A or B (W103/W104)	
M1068A3	
Replacement.....	0854 00-1
W124	
M1068A3	
Replacement.....	0855 00-1
W126	
M1068A3	
Replacement.....	0856 00-1
W45	
M1068A3	
Replacement.....	0853 00-1
Cables and switch assembly	
M14 NBC	
M1059A3	
Replacement.....	0799 00-1
Cap	
Muffler	
Replacement.....	0223 00-1
Cargo hatch cover	
M113A3 and M1059A3	
Replacement.....	0479 00-1

INDEX, cont'd

<u>Subject</u>	<u>WP Sequence No.-Page No.</u>
Cargo hatch hold-open hook and bumpers	
M113A3 and M1059A3	
Replacement.....	0474 00-1
Cargo hatch interior latch	
M113A3 and M1059A3	
Replacement.....	0475 00-1
Cargo hatch seals	
M113A3 and M1059A3	
Replacement.....	0478 00-1
Wheel assembly	
Drive sprocket	
Repair.....	0421 00-1
Carrier does not move in any shift lever position.....	0062 00-1
Carrier drifts or does not steer.....	0063 00-1
Carrier moves with transmission in SL.....	0061 00-1
Carrier does not attain high speed.....	0061 01-1
Cascade Remote Harness	
M1068A3	
Replacement.....	0847 00-1
Catches and bumpers	
Mortar hatch exterior	
M1064A3	
Replacement.....	0480 00-1
Chain Assembly, Litter Kit	
M113A3	
Repair.....	0745 00-1
Chain Assembly, Litter Kit	
M113A3	
Replace.....	0744 00-1
Chemical Agent Automatic Alarm Kit	
Junction Box	
M113A3	
Repair.....	0920 00-1
M113A3	
Installation/Removal.....	0918 00-1
Junction Box	
Replacement.....	0919 00-1
Refill Tray Bracket	
M113A3	
Replacement.....	0922 00-1

INDEX, cont'd

<u>Subject</u>	<u>WP Sequence No.-Page No.</u>
Spare Battery	
M113A3	
Replace/Repair	0921 00-1
Wiring Harnesses, M43 Unit Interface	
M113A3	
Replacement.....	0923 00-1
Circuit breaker	
Dome light	
M577A3 and M1068A3	
Replacement.....	0316 00-1
Replacement	0280 00-1
Circuit breakers	
Bilge pump	
Replacement	0275 00-1
Rear utility receptacle	
M577A3 and M1068A3 only	
Replacement.....	0276 00-1
Clamps	
Tent	
M577A3	
Replacement.....	0627 00-1
Coil	
Air Box Ignition	
Replacement	0208 00-1
Combat filler cover and lock	
Replacement	0466 00-1
Combat lock	
Power plant door	
Replacement.....	0473 00-1
Commander's Cupola	
Armor Shields	
M113A3, M1059A3, and M1064A3	
Replacement.....	0747 00-1
Commander's cupola azimuth lock	
M113A3, M1059A3, M58, and M1064A3	
Replacement	0489 00-1
Commander's cupola brake assembly	
M113A3, M1059A3, M58, and M1064A3	
Replacement	0492 00-1
Commander's cupola cover	
M113A3, M1059A3, and M1064A3	
Replacement.....	0493 00-1
Commander's cupola cushioning pad and handle	

INDEX, cont'd

<u>Subject</u>	<u>WP Sequence No.-Page No.</u>
M113A3, M1059A3, M58, and M1064A3 Replacement	0488 00-1
Commander's cupola hold-open hook and bumper M113A3, M1059A3, M58, and M1064A3 Replacement	0494 00-1
Commander's cupola interior latch M113A3, M1059A3, M58, and M1064A3 Replacement	0496 00-1
Commander's cupola machine gun mount M113A3, M1059A3, M58, and M1064A3 Repair	0498 00-1
Replacement	0497 00-1
Commander's cupola machine gun mount stops M1059A3 Replacement	0499 00-1
Commander's cupola safety pin stowage block M113A3, M1059A3, M58, and M1064A3 Replacement	0495 00-1
Commander's cupola vision block locks and seals M1064A3 Replacement	0491 00-1
M113A3 and M1059A3, M58 Replacement	0490 00-1
Commander's Display Mounting Bracket (DVE) M58 Replacement	0866 06-1
Commander's hatch cover M577A3 and M1068A3 Replacement	0503 00-1
Commander's hatch cushioning pad and handle M577A3 and M1068A3 Replacement	0500 00-1
Commander's hatch hook and bumper M577A3 and M1068A3 Replacement	0501 00-1
Commander's hatch interior latch M577A3 and M1068A3 Replacement	0502 00-1
Commander's Intercommunication Set Cable M58 Replacement	0893 00-1

INDEX, cont'd

<u>Subject</u>	<u>WP Sequence No.-Page No.</u>
Commander's Jump Seat	
M113A3	
Replacement.....	0563 00-1
Commander's platform	
M113A3, M1059A3, M1064A3, and M58	
Replacement/repair.....	0559 00-1
Commander's Platform and Post	
M577A3 and M1068A3	
Replacement/Repair	0564 00-1
Commander's Seat	
M1068A3	
Replacement/repair.....	0566 00-1
Commander's seat	
M113A3, M1059A3, M1064A3, and M58	
Repair	0562 00-1
Commander's Seat and Post	
M1064A3	
Replacement.....	0561 00-1
M113A3, M1059A3, and M58	
Replacement.....	0560 00-1
Commander's Vision Enhancer (DVE) display does not work.....	0116 02-1
Communication Box A11, External	
Lid and Latches	
Replace (M1068A3).....	0818 00-1
Communication Box A11, External (M1068A3)	
Replace	0817 00-1
Communication Cabling Diagram	
M58	0884 00-1
Confidence test diagnostic troubleshooting	
STE/ICE	0139 00-1
Connector assembly	
M13 Orifice	
M1068A3 only	
Replace.....	0781 00-1
Connector assembly, bracket, and quick coupling half	
M13 Orifice	
M1068A3 only	
Replace.....	0781 00-1
Control Assembly and Bearing	
Tow Start	
Replacement.....	0391 00-1

INDEX, cont'd

<u>Subject</u>	<u>WP Sequence No.-Page No.</u>
Control assembly, bracket, links, and pins (cable-activated lock)	
Push-pull	
Replacement.....	0429 00-1
Control Box	
Coolant Heater	
Repair.....	0737 00-1
Replacement.....	0736 00-1
Personnel Heater	
Repair.....	0702 00-1
Replacement.....	0701 00-1
Control Cable Assembly	
Fuel Cutoff	
Replacement.....	0220 00-1
Hand throttle	
Replacement.....	0219 00-1
Control cable assembly	
Parking brake	
Replacement.....	0411 00-1
Control lever assembly	
Parking brake	
Replacement.....	0412 00-1
Control linkage	
Service brake	
Adjustment.....	0407 00-1
Replacement.....	0410 00-1
Trim vane	
Repair.....	0461 00-1
Control Valve	
Fire Extinguisher	
Replacement.....	0904 00-1
Control Valve (with Internal Relief Valve)	
Ramp	
Replacement.....	0661 00-1
Controller	
Glow plug	
Replacement.....	0210 00-1
Controller Mounting Bracket	
Glow Plug	
Replacement.....	0212 00-1
Coolant Air Separator	
Replacement.....	0236 00-1

INDEX, cont'd

<u>Subject</u>	<u>WP Sequence No.-Page No.</u>
Coolant Heater	
Control Box	
Repair	0737 00-1
Replacement	0736 00-1
Coolant	
Heater to Engine Elbow, Replace	0715 00-1
Exhaust Elbow and Pipes	
Replacement	0724 00-1
Fuel Pump	
Replacement	0723 00-1
Fuel Shutoff Valve	
Replacement	0720 00-1
Hoses	
Fuel	
Inlet, Replace	0712 00-1
Hoses	
Coolant	
Pump to Battery Box, Replace	0713 00-1
Fuel	
Filter Valve, Replace	0716 00-1
Pump, Replace	0711 00-1
Pump	
Replacement	0731 00-1
Replace	0728 00-1, 0729 00-1
Wiring Harness	
Replacement	0735 00-1
Coolant Heater and Pump	
Bracket	
Replacement	0732 00-1
Coolant Heater Fuel Filter	
Service	0708 00-1
Coolant Heater Fuel Pump	
Service	0709 00-1
Coolant heater malfunctions	0089 00-1
Coolant Heater to Surge Tank Hose	
Replacement	0725 00-1
Coolant Hose and Tube	
Upper	
Replacement	0232 00-1
Coolant Pump Belts	
Adjustment	0239 00-1
Coolant temp indicator malfunctions	0053 00-1

INDEX, cont'd

<u>Subject</u>	<u>WP Sequence No.-Page No.</u>
Coolant temperature transmitter	
Replacement	0321 00-1
Cooling system	
Drain and fill	0227 00-1
Cover	
Antenna	
Replacement	0576 00-1
Battery box access	
M577A3 and M1068A3	
Repair	0352 00-1
Cargo hatch	
M113A3 and M1059A3	
Replacement	0479 00-1
Commander's cupola	
M113A3, M1059A3, and M1064A3	
Replacement	0493 00-1
Commander's hatch	
M577A3 and M1068A3	
Replacement	0503 00-1
Driver's Hatch	
Replacement	0531 00-1
Fan drive pulley access	
Removal/installation	0440 00-1
Thermostat	
Replacement	0237 00-1
Tow Start Control Assembly	
Replacement	0392 00-1
Covers	
Mortar hatch	
Cushioning Pad	
Driver's Hatch	
Replacement	0530 00-1
Cushioning pad and handle	
Commander's cupola	
M113A3, M1059A3, M58, and M1064A3	
Replacement	0488 00-1
Commander's hatch	
M577A3 and M1068A3	
Replacement	0500 00-1
Cushions	
Personnel	
M113A3	
Replacement	0546 00-1

INDEX, cont'd

<u>Subject</u>	<u>WP Sequence No.-Page No.</u>
M577A3	
Replacement.....	0547 00-1
Personnel Seat	
M1059A3	
Replacement.....	0549 00-1
M1064A3	
Replacement.....	0550 00-1
Cylinder	
Fire Extinguisher	
Discharge Tubes	
Replacement.....	0899 00-1
Ramp	
Replacement.....	0656 00-1
Cylinder, Turbine	
Fire Extinguisher Discharge Tubes	
M58	
Replacement.....	0900 00-1
D	
Data Panel Assembly	
A13 Roadside	
M1068A3	
Replacement.....	0835 00-1
Data Panel Assembly (M1068A3)	
A12, Curbside	
Replace.....	0819 00-1
Data Plates, Stencils, Markers, and Decals	
Replacement.....	0654 00-1
Dataplates, Decals, and Markers	
All Models.....	0644 00-1
M1059A3.....	0651 00-1
M1064A3.....	0652 00-1
M113A3, M1059A3.....	0647 00-1
M113A3, M1059A3, M58.....	0646 00-1
M113A3, M1059A3.....	0645 00-1
M577A3, M1068A3 Only.....	0648 00-1
M58.....	0653 00-1
DC Battery Cable (W4)	
M1068A3	
Replacement.....	0838 00-1
DC Power Extension Box A9	
M1068A3	
Replacement.....	0834 00-1
DC Power Extension Cable (W10)	

INDEX, cont'd

<u>Subject</u>	<u>WP Sequence No.-Page No.</u>
M1068A3	
Replacement.....	0844 00-1
DCA battery voltage diagnostic troubleshooting	0141 00-1
DCA current shunt diagnostic troubleshooting	0142 00-1
Detector	
Auxiliary tank fluid level	
Replacement.....	0329 00-1
Diagram	
Communication Cabling	
M58	0884 00-1
Differential Pressure Switch	
Fuel Filter	
Replacement.....	0328 00-1
Differential pressure switch	
Replacement.....	0401 00-1
Dipstick	
Transmission oil level filler tube, and adapter	
X200-4	
Replacement.....	0395 00-1
X200-4A	
Replacement.....	0396 00-1
Discharge Tubes	
Cylinder	
Replacement.....	0899 00-1
Cylinder, Turbine	
M58	
Replacement.....	0900 00-1
STE/ICE	
M1064A3	
Replacement.....	0877 00-1
M113A3 and M1059A3	
Replacement.....	0874 00-1
M577A3 and M1068A3	
Replacement.....	0875 00-1
Distribution box	
M113A3, M1059A3, M1064A3, and M58	
Replacement.....	0269 00-1
M113A3, M1059A3, M1064A3, and M58 only	
Repair.....	0270 00-1
M577A3 and M1068A3 only	
Replacement.....	0271 00-1

INDEX, cont'd

<u>Subject</u>	<u>WP Sequence No.-Page No.</u>
Dome blackout light bypass switch	
M577A3 and M1068A3	
Replacement.....	0317 00-1
Dome light	
All Except M577A3 and M1068A3	
Repair.....	0310 00-1
Replacement.....	0309 00-1
M577A3 and M1068A3	
Repair.....	0312 00-1
Replacement.....	0311 00-1
Dome light and mount	
M577A3 and M1068A3	
Repair.....	0312 00-1
Dome light circuit breaker	
M577A3 and M1068A3	
Replacement.....	0316 00-1
Dome light lens	
All Except M577A3 and M1068A3	
Replacement.....	0313 00-1
Dome light malfunction	
M577A3 only.....	0040 00-1
Dome light switch	
Front	
M577A3 and M1068A3	
Replacement.....	0314 00-1
Rear	
M577A3 and M1068A3	
Replacement.....	0315 00-1
Dome light(s) do not work.....	0039 00-1
Door	
Power plant	
All except M113A3	
Replacement.....	0471 00-1
M113A3	
Replacement.....	0470 00-1
Repair.....	0472 00-1
Door combat lock	
Power plant	
Replacement.....	0473 00-1
Drain Check Valve and tubes	
Left Air Box	
Replace.....	0159 00-1

INDEX, cont'd

<u>Subject</u>	<u>WP Sequence No.-Page No.</u>
Drain Cock and Hose	
Replacement	0235 00-1
Drain plug	
Hull	
Replacement	0451 00-1
Drain plugs	
Final drive hull	
Replacement	0452 00-1
Fuel tank	
All except M577A3 and M1068A3	
Replacement	0187 00-1
Ramp	
Replacement	0515 00-1
Drawer	
Battery	
M1064A3	
Repair	0353 00-1
Drive Belt	
Ventilating Fan	
Adjustment	0242 00-1
Replacement	0243 00-1
Drive belt	
Generator	
Replacement	0253 00-1
Drive Pulley	
Ventilating Fan	
Replacement	0244 00-1
Drive shaft and bearing housing	
Fan	
Replacement	0248 00-1
Drive sprocket and wheel assembly	
Replacement	0420 00-1
Drive sprocket wheel assembly	
Drive sprocket	
Repair	0420 01-1, 0421 00-1
Driver's compartment floor plates	
Replacement	0453 00-1
Driver's Display Mounting Bracket (DVE)	
M58	
Replacement	0866 02-1
Driver's footrest	
Replacement	0558 00-1

INDEX, cont'd

<u>Subject</u>	<u>WP Sequence No.-Page No.</u>
Driver's Hatch	
Bumper	
M113A3, M1059A3, M1064A3, and M58	
Replacement.....	0532 00-1
Cushioning Pad	
Replacement.....	0530 00-1
Exterior Lock	
Replacement.....	0531 00-1
Hold-open Hook	
M113A3, M1059A3, M1064A3, and M58	
Replacement.....	0532 00-1
Driver's hatch night vision mount	
M58	
Replacement.....	0537 01-1
Driver's Intercommunication Set	
Cable	
M58	
Replacement.....	0892 00-1
Driver's night vision (DNV) (AN/VVS-2) power supply cable assembly	
All Except M58	
Replacement.....	0368 00-1
Driver's night vision guard (AN/VVS-2)	
Driver's Hatch	
All Except M58	
Replacement.....	0536 00-1
Driver's night vision mount	
AN/VVS-2	
All Except M58	
Replacement.....	0537 00-1
Driver's night vision mount (AN/VVS-2)	
All Except M58	
Replacement.....	0537 00-1
Driver's Night Vision Stowage	
AN/VVS-2	
All Except M58	
Replacement.....	0572 00-1
Driver's power plant access panel	
Replacement.....	0441 00-1
Driver's Seat	
Repair.....	0552 00-1
Driver's seat assembly	
Replacement.....	0551 00-1

INDEX, cont'd

<u>Subject</u>	<u>WP Sequence No.-Page No.</u>
Driver's seat back assembly	
Repair	0554 00-1
Replacement	0553 00-1
Driver's seat impact absorber	
Replacement	0555 00-1
Driver's seat post assembly	
Repair	0557 00-1
Replacement	0556 00-1
Driver's Vision Enhancer (DVE) AN/VAS-5 Power Supply Cable M58	
Replacement	0866 04-1
Driver's Vision Enhancer (DVE) display does not work	0116 01-1
Driver's windshield	
Replacement	0739 00-1
towage bag, straps, and decal	
Replacement	0740 00-1
DVE Sensor Set Assembly Power Cable M58	
Replacement	0866 01-1
E	
Elbow	
Air intake	
Replace	0173 00-1
Coolant Heater Exhaust	
Replacement	0724 00-1
Electrical Cable Assembly	
Air Compressor	
M1059A3	
Replacement	0758 00-1
Fog Oil Pump	
M1059A3	
Replacement	0759 00-1
Element	
Filter	
Air Cleaner	
Service	0167 00-1
Enclosure	
Generator set	
M577A3 and M1068A3	
Replacement	0674 00-1

INDEX, cont'd

<u>Subject</u>	<u>WP Sequence No.-Page No.</u>
Enclosure Assembly A1	
Power Control	
M1068A3	
Replacement.....	0826 00-1
Engine	
Adapter, Tachometer	
Replace.....	0863 00-1
Block Fitting and Hardware	
Replacement.....	0717 00-1
Exhaust elbows	
Left/right, replace.....	0225 00-1
Fuel return hose	
Replacement.....	0201 00-1
Fuel supply hose	
Replacement.....	0200 00-1
Lifting bracket, replace.....	0161 00-1
Oil filler cap, replace.....	0162 00-1
Oil sampling valve and hose, replace.....	0163 00-1
Engine Coolant Heater System	
Drain and Fill.....	0710 00-1
Engine coolant low level indicator malfunctions.....	0058 00-1
Engine Coolant Pump	
Replacement.....	0241 00-1
Engine cranks but will not start.....	0021 00-1
Engine cranks but won't start below 40 degrees (air box heater is used).....	0022 00-1
Engine cranks but won't start below 40 degrees F (glow plugs are used).....	0023 00-1
Engine cranks slowly.....	0020 00-1
Engine does not crank.....	0016 00-1
Engine does not start (cold weather only).....	0017 00-1
Engine exhaust elbows and double flex joint	
Replacement.....	0221 00-1
Engine fuel pump	
Replacement.....	0166 00-1
Engine Mounts	
Replace.....	0158 00-1
Engine oil low pressure indicator comes on.....	0026 00-1
Engine oil low pressure indicator malfunctions.....	0055 00-1
Engine oil low pressure transmitter and hardware	
Replacement.....	0320 00-1
Engine overcools.....	0015 00-1
Engine overheats (Old VSFD Configuration).....	0014 00-1
Engine overheats (New VSFD Configuration).....	0014 01-1
Engine runs rough, stalls, or doesn't put out full power.....	0024 00-1

INDEX, cont'd

<u>Subject</u>	<u>WP Sequence No.-Page No.</u>
Engine start switch	
Replacement	0284 00-1
Engine to battery box hose	
Replacement	0714 00-1
Engine wiring harness	
Replacement	0359 00-1
Equipment Description	0002 00-1
Location and Description of Major Components	0002 00-1
Evacuator valve and connector	
Exhaust	
Replace	0175 00-1
Exhaust	
Evacuator valve and connector	
Replace	0175 00-1
Exhaust elbows and double flex joint	
Engine	
Replacement	0221 00-1
Exhaust Joint, Double Flex, Repair	0222 00-1
Exhaust muffler and bracket	
Replace	0224 00-1
Exhaust Pipe Heat Shield, Turbo, Left/Right, Replace	0226 00-1
Exhaust Pipes, Heater	
All Except M1064A3	
Replacement	0682 00-1
Expendable/Durable Supplies and Materials List	0928 00-1
Extender Assembly	
Tow Pintle	
M113A3	
Repair	0811 02-1
Extender Kit	
Tow Pintle	
M113A3	
Installation	0811 01-1
Extension	
Muffler	
Replacement	0223 00-1
Engine overheats (New VSFD Configuration)	0014 01-1
Extension Box A7	
AC Power	
Replace	0815 00-1

INDEX, cont'd

<u>Subject</u>	<u>WP Sequence No.-Page No.</u>
Exterior catches and bumpers	
Mortar hatch	
M1064A3	
Replacement.....	0480 00-1
Exterior Lock	
Driver's Hatch	
Replacement.....	0531 00-1
External Cable Tube	
Replacement.....	0905 00-1
External Handle	
Fire Extinguisher	
Replacement.....	0904 00-1
External Handle Shield	
M1064A3	
Replacement.....	0903 00-1
M113A3 and M1059A3	
Replacement.....	0901 00-1
M577A3 and M1068A3	
Replacement.....	0902 00-1
Extinguisher, Fire	
Cylinder and Mount	
Replacement.....	0898 00-1
F	
Fan	
Variable Speed Drive	0249 00-1
Fan	
Variable Speed Drive	
Fan Drive Assembly.....	0249 01-1
Fan	
Variable Speed Drive	
Controller	0250 01-1
Fan	
Ventilation	
M577A3 and M1068A3	
Replacement.....	0383 00-1
Fan and generator variable speed drive	
Replacement.....	0249 00-1
Fan drive pulley access cover	
Removal/installation	0440 00-1
Fan drive shaft and bearing housing	
Replacement.....	0248 00-1

INDEX, cont'd

<u>Subject</u>	<u>WP Sequence No.-Page No.</u>
Field pressure switch	
Generator	
Replacement.....	0323 00-1
Filler Cap	
Strainer Parts	
All Except M577A3 and M1068A3	
Replacement.....	0184 00-1
M577A3 and M1068A3	
Replacement.....	0185 00-1
Filler Cover and Lock	
Fuel Tank	
All Except M577A3 and M1068A3	
Replacement.....	0182 00-1
Filler Flange	
Fuel Tank	
M577A3 and M1068A3	
Replacement.....	0189 00-1
Filler tube	
Dipstick, transmission oil level	
X200-4	
Replacement.....	0395 00-1
X200-4A	
Replacement.....	0396 00-1
Filler tube and dipstick	
Final drive	
Replacement.....	0402 00-1
Filler, fuel and strainer parts	
M577A3 and M1068A3	
Replacement.....	0186 00-1
Filter	
Fuel	
Replacement.....	0726 00-1
Filter Element	
Transmission oil	
Replacement.....	0398 00-1
Filter Fuel Supply Hoses	
M113A3, M1059A3, and M58	
Replacement.....	0685 00-1
Final drive	
Replacement.....	0403 00-1
Final drive differential oil seal	
Replacement.....	0404 00-1

INDEX, cont'd

<u>Subject</u>	<u>WP Sequence No.-Page No.</u>
Final drive filler tube and dipstick	
Replacement	0402 00-1
Final drive hull drain plugs	
Replacement	0452 00-1
Fire Extinguisher	
Cylinder and Mount	
Replacement	0898 00-1
Fire Extinguisher	
Control Valve	
Replacement	0904 00-1
External Handle	
Replacement	0904 00-1
M1059A3	
Replacement	0896 00-1
Fittings	
Coolant Heater Fuel Inlet	
Replace	0712 00-1
Fuel Return	
M1064A3	
Replacement	0197 00-1
M113A3, M1059A3, and M58	
Replacement	0195 00-1
M577A3 and M1068A3	
Replacement	0196 00-1
Fuel Vent	
M577A3 and M1068A3	
Replacement	0198 00-1
Personnel heater	
M577A3 and M1068A3	
Replacement	0700 00-1
Ramp Control Valve (with Internal Relief Valve)	
Replacement	0661 00-1
Flame Detector Switch	
Adjust	0727 00-1
Coolant Heater	
Replacement	0734 00-1
Flat pulleys and bearings	
Replacement	0245 00-1
Floor Plates	
M1059A3	
Replacement	0542 00-1
M1064A3	
Replacement	0543 00-1

INDEX, cont'd

<u>Subject</u>	<u>WP Sequence No.-Page No.</u>
M1068A3	
Replacement.....	0544 00-1
M113A3 and M577A3	
Replacement.....	0539 00-1
M58	
Replacement.....	0545 00-1
Floor plates	
Driver's compartment	
Replacement.....	0453 00-1
Fluid level detector	
Auxiliary tank	
Replacement.....	0329 00-1
Fluorescent Light Assemblies	
M1068A3	
Replacement.....	0825 00-1
Fluorescent lights do not operate	
M1068A3 only	0102 00-1
Fog Oil Pump	
Electrical Cable Assembly	
M1059A3	
Replacement.....	0759 00-1
Fog Oil Pump Assembly	
(M1059A3 Only)	
Replace.....	0763 00-1
Fog Oil Quick Disconnect to Adapter Access Plate Hose (M1059A3), Cover Assembly	
Replace.....	0770 00-1
Fog Oil Tank (M1059A3)	
Hose	
Quick Disconnect to Adapter Access Plate	
Replace.....	0769 00-1
Fog Oil Tank Module	
M1059A3	
Replacement.....	0753 00-1
Footrest	
Driver's	
Replacement.....	0558 00-1
Forward spall liner and bracket	
M113A3	
Replacement.....	0507 00-1
Forward Table, Right	
M577A3	
Replacement.....	0581 00-1

INDEX, cont'd

<u>Subject</u>	<u>WP Sequence No.-Page No.</u>
Forward upper right and left side spill liners	
M113A3	
Replacement.....	0508 00-1
Frame	
Blackout Curtain	
M577A3 and M1068A3	
Replacement.....	0629 00-1
Front access cover	
Hull	
Replacement.....	0449 00-1
Front and/or rear bilge pump(s) and/or lights don't work.....	0080 00-1
Front Armor	
M113A3	
Replacement.....	0749 00-1
Front armor plate	
Left	
Replacement.....	0447 00-1
Right	
Replacement.....	0448 00-1
Front Bilge Pump	
Replace.....	0632 00-1
Strainer	
Replace.....	0632 00-1
Front Bilge Valve	
Replace.....	0633 00-1
Front dome light switch	
M577A3 and M1068A3	
Replacement.....	0314 00-1
Fuel Shutoff Valve	
Coolant Heater	
Replacement.....	0720 00-1
Fuel Can Lid Assembly	
Smoke Generator (M1059A3)	
Replace.....	0764 00-1
Fuel cap vent and filter screen, clean.....	0176 00-1
Fuel Control Linkage	
Replacement.....	0217 00-1
Fuel Control Shaft	
Replacement.....	0217 00-1
Fuel Cutoff Control Cable Assembly	
Replacement.....	0220 00-1
Fuel Filters and Brackets	
Primary and Secondary.....	0203 00-1

INDEX, cont'd

<u>Subject</u>	<u>WP Sequence No.-Page No.</u>
Fuel Filter	
Coolant Heater	
Service.....	0708 00-1
Replacement.....	0726 00-1
Fuel filter	
Personnel heater	
M577A3 and M1068A3	
Replacement.....	0700 00-1
Fuel Filter Differential Pressure Switch	
Replacement.....	0328 00-1
Fuel Filter Elements	
Primary and Secondary	
Replacement.....	0202 00-1
Fuel filter, hose, tube, and fittings	
Personnel heater	
M577A3 and M1068A3	
Replacement.....	0700 00-1
Fuel filter, hoses, and fittings	
Personnel heater	
M1064A3	
Replacement.....	0688 00-1
Fuel Filters and Brackets	
Primary and Secondary	
Replacement.....	0203 00-1
Fuel level indicator malfunctions .	0049 00-1
Fuel Line	
Lower	
Air Box Heater	
Replacement.....	0206 00-1
Fuel Lines	
Air From Personnel Heater	
Bleed	0679 00-1
Fuel Lines and Guards	
Smoke Generator (M1059A3)	
Replace.....	0765 00-1
Fuel Pump	
Coolant Heater	
Replacement.....	0723 00-1
Service.....	0709 00-1
Personnel Heater	
M113A3, M1059A3, and M58	
Replacement.....	0695 00-1

INDEX, cont'd

<u>Subject</u>	<u>WP Sequence No.-Page No.</u>
Fuel pump	
Engine	
Replacement.....	0166 00-1
Fuel Pump Hose	
Coolant Heater	
Replace.....	0711 00-1
Fuel quantity transmitter	
All except M577A3 and M1068A3	
Replacement.....	0190 00-1
M577A3 and M1068A3	
Replacement.....	0191 00-1
Fuel return hoses	
Engine	
Replacement.....	0201 00-1
M1064A3	
Replacement.....	0197 00-1
M 113A3, M1059A3, and M58	
Replacement.....	0195 00-1
M577A3 and M1068A3	
Replacement.....	0196 00-1
Fuel return pressure transducer	
Replacement.....	0325 00-1
Fuel select switch to gauge lead	
All Except M577A3 and M1068A3	
Replacement.....	0281 00-1
Fuel selector switch	
M577A3 and M1068A3 only	
Replacement.....	0277 00-1
Fuel Shut-off Valve assembly	
M113A3, M1059A3, and M58	
Replacement.....	0684 00-1
Fuel Shutoff Valve	
Auxiliary Power Unit	
M577A3 and M1068A3	
Replacement.....	0676 00-1
Fuel Supply	
Hoses, Tubes, and Fittings	
M1064A3	
Replacement.....	0194 00-1
M113A3, M1059A3, and M58	
Replacement.....	0192 00-1

INDEX, cont'd

<u>Subject</u>	<u>WP Sequence No.-Page No.</u>
Fuel supply	
Hoses, tubes, and fittings	
M577A3 and M1068A3	
Replacement.....	0193 00-1
Fuel Supply Hoses	
Auxiliary Power Unit Valve-to-bulkhead	
M577A3 and M1068A3	
Replacement.....	0677 00-1
Fuel supply hoses	
Auxiliary power unit bulkhead-to-hull	
M577A3 and M1068A3	
Replacement.....	0678 00-1
Engine	
Replacement.....	0200 00-1
Fuel supply pressure transducer	
Replacement.....	0324 00-1
Fuel Tank	
Filler Cover and Lock	
All Except M577A3 and M1068A3	
Replacement.....	0182 00-1
Filler Flange	
M577A3 and M1068A3	
Replacement.....	0189 00-1
Fuel tank access covers	
M577A3 and M1068A3	
Replacement.....	0188 00-1
Fuel tank drain plugs	
M577A3 and M1068A3	
Replacement.....	0187 00-1
Fuel tank filler	
Cover and lock	
M577A3 and M1068A3	
Replacement.....	0183 00-1
Fuel Tank to Fuel Pump Hose	
M577A3 and M1068A3	
Replacement.....	0690 00-1
Fuel Tanks	
Drain	
M577A3 and M1068A3	0178 00-1

INDEX, cont'd

<u>Subject</u>	<u>WP Sequence No.-Page No.</u>
Fuel tanks	
All except M577A3 and M1068A3, replace	0179 00-1
Drain	
All except M577A3 and M1068A3.....	0177 00-1
M577A3 and M1068A3	
Replacement.....	0180 00-1
Temporary repair (M577A3 and M1068A3).....	0181 00-1
Fuel Tube	
Personnel Heater	
All Except M1064A3	
Replacement.....	0686 00-1
Fuel Valve	
Mounting Blocks	
All Except M577A3 and M1068A3	
Replacement.....	0199 00-1
Fuel Vent Hoses, Tubes, and Fittings	
M577A3 and M1068A3	
Replacement.....	0198 00-1
G	
Gasket	
Adapter Access Plate	
Smoke Generator (M1059A3)	
Replace.....	0766 00-1
Turbine access door	
M58	
Replacement.....	0486 00-1
Gauges	
Instrument panel	
Replacement.....	0285 00-1
General Information	0001 00-1
Generator	
Drive belt	
Replacement.....	0253 00-1
Replacement.....	0255 00-1
Turnbuckle parts	
Replacement.....	0254 00-1
Generator	
Variable Speed Drive	0249 00-1
Generator drive belt	
Adjustment	0252 00-1
Generator field pressure switch	
Replacement.....	0323 00-1
Generator malfunctions as indicated by battery/generator indicator.....	0025 00-1

INDEX, cont'd

<u>Subject</u>	<u>WP Sequence No.-Page No.</u>
Generator set	
Enclosure	
M577A3 and M1068A3	
Replacement.....	0674 00-1
Glow Plug	
Controller Mounting Bracket	
Replacement.....	0212 00-1
Glow Plug Cable Assembly	
Smoke Generator (M1059A3)	
Replace.....	0772 00-1
Glow plug controller	
Replacement.....	0210 00-1
Glow plug harness	
Replacement.....	0209 00-1
Glow Plug Power Harness	
Replacement.....	0211 00-1
Glow plugs	
Replacement.....	0209 00-1
Governor assembly	
Replacement.....	0397 00-1
Grenade Stowage box	
M1064A3	
Replacement.....	0610 00-1
Grill	
Air Intake elbow and hose	
Replace.....	0174 00-1
Grill screen	
Power plant	
Replacement.....	0468 00-1
Grill support arm	
Power plant	
Replacement.....	0467 00-1
Grille	
Power plant	
Raise and lower.....	0464 00-1
Removal/installation.....	0465 00-1
Ground lead	
Auxiliary power (slave) receptacle	
M113A3, M1059A3, M1064A3, and M58	
Replacement.....	0379 00-1

INDEX, cont'd

<u>Subject</u>	<u>WP Sequence No.-Page No.</u>
Battery	
M577A3 and M1068A3	
Connect	0338 00-1
Disconnect	0338 00-1
Ground Strap (W12)	
M1068A3	
Replacement	0846 00-1
Guard	
Antenna	
Replacement	0575 00-1
Driver's Hatch Night Vision	
M58	
Replacement	0536 01-1
Headlight	
Replacement	0446 00-1
Smoke grenade launcher	
M113A3 and M1059A3 only	
Replacement	0455 00-1
H	
Hand Throttle Control Cable Assembly	
Replacement	0219 00-1
Handle and Arms	
Ramp Lock	
All Except M577A3 and M1068A3	
Replacement	0524 00-1
Harness	
Cascade Remote	
M1068A3	
Replacement	0847 00-1
Glow plug	
Replacement	0209 00-1
Trailer	
Replacement	0375 00-1
Harness W32	
M1068A3	
Replacement	0848 00-1
Headlight	
Blackout	
Repair	0306 00-1
Replacement	0305 00-1
Headlight guard	
Replacement	0446 00-1

INDEX, cont'd

<u>Subject</u>	<u>WP Sequence No.-Page No.</u>
Headlight high beam selector switch	
Replacement	0333 00-1
Headlights	
Service and infrared	
Repair	0304 00-1
Replacement	0303 00-1
Heat Exchanger	
Battery Box	
Replacement	0718 00-1
Battery Drawer	
M1064A3	
Replacement	0719 00-1
Heat shield	
Turbo exhaust pipe	
Left/right, replace	0226 00-1
Water/Ration	
Mount Bracket (M113A3 Only)	
Replace	0811 00-1
Power Cable (M113A3 Only)	
Replace	0810 00-1
Heater Control Box	
M3 NBC	
M577A3	
Replacement	0792 00-1
Heater control box	
M3 NBC	
M1068A3	
Replacement	0793 00-1
Heater Fuel Supply Hoses	
M113A3 and M58	
Replacement	0685 00-1
Heater Hoses and Fittings	
M3 NBC	
Replace	0784 00-1
Heaters and Controllers	
M3 NBC	
M113A3 Ambulances	
Replacement	0795 00-1
High beam indicator light doesn't work	0050 00-1
High beam selector switch	
Headlight	
Replacement	0333 00-1

INDEX, cont'd

<u>Subject</u>	<u>WP Sequence No.-Page No.</u>
Hinges	
Turbine access door	
M58	
Replacement.....	0487 00-1
Hold-open Hook	
Driver's Hatch	
M113A3, M1059A3, M1064A3, and M58	
Replacement.....	0532 00-1
Hold-Open Hook and Bumper	
Driver's Hatch	
M577A3 and M1068A3	
Replacement.....	0533 00-1
Hold-open hook and bumper	
Commander's cupola	
M113A3, M1059A3, M58, and M1064A3	
Replacement.....	0494 00-1
Hook and bumper	
Commander's cupola hold-open	
M113A3 and M1059A3	
Replacement.....	0494 00-1
Commander's hatch	
M577A3 and M1068A3	
Replacement.....	0501 00-1
Hook and bumpers	
Cargo hatch hold-open	
M113A3 and M1059A3	
Replacement.....	0474 00-1
Hook and Eye	
Towing	
Replacement.....	0443 00-1
Hopper hatch	
M58	
Replacement.....	0484 00-1
Hopper hatch lock assembly	
M58	
Replacement.....	0483 00-1
Horn and ground lead	
Replacement.....	0336 00-1
Horn does not work	0037 00-1
Horn switch	
All Except M58	
Replacement.....	0293 00-1

INDEX, cont'd

<u>Subject</u>	<u>WP Sequence No.-Page No.</u>
M58	
Replacement.....	0293 01-1
Hose	
Balance	
Replacement.....	0234 00-1
Battery Plate to Battery Plate	
Replacement.....	0722 00-1
Bulkhead to Ramp Cylinder	
Replacement.....	0665 00-1
Coolant Heater to Surge Tank	
Replacement.....	0725 00-1
Engine to battery box	
Replacement.....	0714 00-1
Fuel Pump Tee To Elbow	
Replacement.....	0721 00-1
Fuel Pump to Bulkhead Connection	
M113A3 , M1059A3, and M58	
Replacement.....	0691 00-1
Fuel return	
Engine	
Replacement.....	0201 00-1
Fuel supply	
Engine	
Replacement.....	0200 00-1
Fuel Tank to Fuel Pump	
M577A3 and M1068A3	
Replacement.....	0690 00-1
Personnel heater	
M577A3 and M1068A3	
Replacement.....	0700 00-1
Quick Disconnect to Adapter Access Plate	
Fog Oil Tank (M1059A3)	
Replace.....	0769 00-1
Hose, restriction indicator	
Air cleaner	
Replace.....	0172 00-1
Hoses	
Auxiliary power unit bulkhead-to-hull fuel supply	
M577A3 and M1068A3	
Replacement.....	0678 00-1
Auxiliary Power Unit Valve-to-bulkhead Fuel Supply	
M577A3 and M1068A3	
Replacement.....	0677 00-1

INDEX, cont'd

<u>Subject</u>	<u>WP Sequence No.-Page No.</u>
■ Filter Fuel Supply	
M113A3, M1059A3, and M58	
Replacement.....	0685 00-1
Fuel Vent	
M577A3 and M1068A3	
Replace.....	0198 00-1
Heater Fuel Supply	
■ M113A3, M1059A3, and M58	
Replacement.....	0685 00-1
M13 NBC heater	
M1068A3 only	
Replace.....	0790 00-1
Thermostat	
Replacement.....	0238 00-1
Transmission oil supply and return	
Replacement.....	0251 00-1
Hoses from thermostat to	
Variable speed drive	
Replacement.....	0250 00-1
Hoses	
■ Thermostat.....	0250 00-1
Hoses from thermostat to variable speed drive	
Replacement.....	0250 00-1
Hoses, Tubes, and Fittings	
Fuel Supply	
M1064A3	
Replacement.....	0194 00-1
■ M113A3, M1059A3, and M58	
Replacement.....	0192 00-1
Hoses, tubes, and fittings	
Fuel supply	
M577A3 and M1068A3	
Replacement.....	0193 00-1
Hose	
Variable Speed Drive	
■ Override Switch.....	0251 00-1
How to Use Troubleshooting	
Introduction.....	0005 00-1
Hub	
Road wheel	
Replacement.....	0416 00-1
Hull	
Repair By Welding.....	0529 00-1

INDEX, cont'd

<u>Subject</u>	<u>WP Sequence No.-Page No.</u>
Hull drain plug	
Replacement	0451 00-1
Hull drain plugs	
Final drive	
Replacement	0452 00-1
Hull front access cover	
Replacement	0449 00-1
Hydraulic Reservoir	
Breather	
Service	0670 00-1
Hydraulic Hoses	
Power Plant	
Replacement	0668 00-1
Hydraulic Pump	
Ramp	
Replacement	0655 00-1
Hydraulic Reservoir	
Repair	0672 00-1
Hydraulic Reservoir	
Replacement	0671 00-1
Service	0669 00-1
I	
Idler Arm	
Replacement	0246 00-1
Idler wheel	
Replacement	0425 00-1
Idler wheel arm assembly	
Replacement	0417 00-1
Idler wheel arm bearings and seals	
Replacement	0418 00-1
Igniter	
Air Heater	
Replacement	0207 00-1
Replacement	0730 00-1
Ignition Coil	
Air Box	
Replacement	0208 00-1
Impact absorber	
Driver's Seat	
Replacement	0555 00-1
In blackout mode, fluorescent lights operate incorrectly	
M1068A3 only	0101 00-1

INDEX, cont'd

<u>Subject</u>	<u>WP Sequence No.-Page No.</u>
Indicator lights	
Replacement	0286 00-1
Infrared headlight(s) don't work	0032 00-1
Initial Installation of Litter Kit	
M113A3	0741 00-1
Inoperable ramp	
Lower	0513 00-1
Raise	0513 00-1
Instrument panel	
Battery-generator gauge, wiring harness	
Replacement	0289 00-1
Instrument panel and/or trans controller illumination lights malfunction	0038 00-1
Instrument Panel Assembly	
All Except M58	
Replacement	0279 00-1
Instrument panel Assembly	
M58	
Replacement	0279 01-1
Instrument panel gauges	
Replacement	0285 00-1
Instrument Panel Mounts and Ground Lead	
All Except M58	
Replacement	0295 00-1
M58	
Replacement	0295 01-1
Instrument panel on-off switches	
Replacement	0282 00-1
Instrument panel special purpose cable	
Replacement	0290 00-1
Instrument Warning Light Panel	
Replacement	0288 00-1
Insulation	
Battery Box	
Replacement	0718 00-1
Battery Drawer	
M1064A3	
Replacement	0719 00-1
Intercom Amplifier	
M58	
Replace	0888 00-1
Intercommunications Set Control	
M58	
Replacement	0885 00-1

INDEX, cont'd

<u>Subject</u>	<u>WP Sequence No.-Page No.</u>
Interior Latch	
Driver's Hatch	
Replacement.....	0534 00-1
Interior latch	
Cargo hatch	
M113A3 and M1059A3	
Replacement.....	0475 00-1
Commander's cupola	
M113A3, M1059A3, M58, and M1064A3	
Replacement.....	0496 00-1
Commander's hatch	
M577A3 and M1068A3	
Replacement.....	0502 00-1
Interior Lock	
Driver's Hatch	
Replacement.....	0534 00-1
Interior release mechanisms	
Mortar hatch	
M1064A3	
Replacement.....	0481 00-1
Intervehicle power cable	
M577A3 and M1068A3	
Replacement.....	0381 00-1
Inverter	
Housing A2 Terminal Blocks TB1 and TB2	
M1068A3	
Replacement.....	0830 00-1
Inverter AC Cable (W5)	
Replacement/Repair	0839 00-1
Inverter DC Cable (W6)	
M1068A3	
Replacement.....	0840 00-1
J	
Jump Seat	
Commander's	
M113A3	
Replacement.....	0563 00-1
Junction Box	
Chemical Alarm	
M113A3	
Repair	0920 00-1

INDEX, cont'd

<u>Subject</u>	<u>WP Sequence No.-Page No.</u>
Power Cable/Alarm Cable, Chemical Alarm	
M113A3	
Replacement.....	0919 00-1
K	
Kit	
Initial Installation of Litter	
M113A3	0741 00-1
Kits	
Armor	
M113A3	
Installation	0748 00-1
Mine Armor	
M113A3	
Installation/Removal	0752 00-1
L	
Lamp	
Transmission range controller	
Replacement.....	0388 00-1
LAN (M1068A3)	
Ground Box Assembly A15	
Repair	0821 00-1
Replace.....	0820 00-1
LAN A or B Cable	
(W103/W104)	
M1068A3	
Replacement.....	0854 00-1
LAN Cable (W40) Single Point	
M1068A3	
Replacement.....	0851 00-1
Latch	
Interior	
Driver's Hatch	
Replacement.....	0338 00-1
Lead	
Battery ground	
M577A3 and M1068A3	
Connect	0338 00-1
Disconnect	0338 00-1
Horn and ground	
Replacement.....	0336 00-1
Power Control Enclosure Circuit 44A	
M1068A3	
Replacement.....	0829 00-1

INDEX, cont'd

<u>Subject</u>	<u>WP Sequence No.-Page No.</u>
Lead (circuit 49)	
Master switch to distribution box	
M113A3 , M1059A3, M1064A3, and M58 only	
Replacement.....	0266 00-1
M577A3 and M1068A3 only	
Replacement.....	0267 00-1
Lead (circuit 50)	
Master switch to auxiliary power receptacle	
M113A3 , M1059A3, M1064A3, and M58	
Replacement.....	0268 00-1
Lead assembly	
Master switch panel dome lights	
M577A3 and M1068A3	
Replacement.....	0380 00-1
Utility outlet	
M577A3 and M1068A3	
Replacement.....	0377 00-1
Leads and terminals	
Battery	
M113A3 and M1059A3	
Replacement.....	0340 00-1
M577A3 and M1068A3	
Replacement.....	0341 00-1
M58	
Replacement.....	0345 00-1
Leads and terminals (left side)	
Battery	
M1064A3	
Replacement.....	0343 00-1
Leads and terminals (right side)	
Battery	
M1064A3	
Replacement.....	0344 00-1
Left Air Box	
Drain Check Valve and tubes	
Replace.....	0159 00-1
Left Bulkhead Radio Stowage Racks	
M577A3 and M1068A3	
Replacement.....	0577 00-1
Left front armor plate	
Replacement.....	0447 00-1
Left rear utility outlet/blower does not work	
M577A3 and M1068A3 only	0043 00-1

INDEX, cont'd

<u>Subject</u>	<u>WP Sequence No.-Page No.</u>
Left Side Rack Base	
M1068A3	
Replacement.....	0616 00-1
Left side spall liners	
M113A3	
Replacement.....	0505 00-1
Left stop light - tail light	
M577A3 and M1068A3	
Replacement.....	0299 00-1
Repair 0300 00-1	
Left Table	
M577A3	
Replacement.....	0578 00-1
Lens	
Dome light	
All Except M577A3 and M1068A3	
Replacement.....	0313 00-1
Lever	
Throttle valve (TV)	
Replacement.....	0218 00-1
Lever and Cable	
Ramp Lock	
M577A3 and M1068A3	
Replacement.....	0525 00-1
Lid and Latches	
External Communication Box A11	
Replace (M1068A3)	0818 00-1
Lifting Eye	
Replacement.....	0444 00-1
Light	
Blackout marker	
Repair.....	0308 00-1
Replacement.....	0307 00-1
Dome	
All Except M577A3 and M1068A3	
Repair.....	0310 00-1
Replacement.....	0309 00-1
M577A3 and M1068A3	
Repair.....	0312 00-1
Replacement.....	0311 00-1

INDEX, cont'd

<u>Subject</u>	<u>WP Sequence No.-Page No.</u>
Light Assemblies	
Fluorescent	
M1068A3	
Replacement.....	0825 00-1
Light Assembly	
Tent	
M577A3 and M1068A3	
Replacement.....	0318 00-1
Light Indicators	
Power Control Enclosure AC and DC	
M1068A3	
Replacement.....	0827 00-1
Light panel	
Instrument warning	
Replacement.....	0288 00-1
Light switch	
Main	
Replacement.....	0283 00-1
Lights	
Indicator	
Replacement.....	0286 00-1
Instrument Panel Warning	
Replacement.....	0287 00-1
Panel	
Replacement.....	0286 00-1
Warning Panel	
M58	
Replacement.....	0294 01-1
Warning panel	
All Except M58	
Replacement.....	0294 00-1
Linkage	
Accelerator	
Adjust	0214 00-1
Fuel Control	
Replacement.....	0217 00-1
Ramp	
M1064A3	
Replacement.....	0528 00-1
M113A3 and M1059A3	
Replacement.....	0526 00-1
M577A3 and M1068A3	
Replacement.....	0527 00-1

INDEX, cont'd

<u>Subject</u>	<u>WP Sequence No.-Page No.</u>
Steering wheel	
Adjustment	0427 00-1
Replacement	0430 00-1
Litter Kit	
Initial Installation of	
M113A3	0741 00-1
Lock	
Interior	
Driver's Hatch	
Replacement	0534 00-1
Ramp	
M1064A3	
Adjustment	0523 00-1
M113A3 and M1059A3	
Adjustment	0521 00-1
M577A3 and M1068A3	
Adjustment	0522 00-1
Lock assembly	
Hopper hatch	
M58	
Replacement	0483 00-1
Locks and Seals	
Vision Block	
Driver's Hatch	
Replacement	0535 00-1
Loops	
Tool Box	
Replacement	0571 00-1
Lower Fuel Line	
Air Box Heater	
Replacement	0206 00-1
M	
M114 NBC Hoses and Brackets	
Replace	0783 00-1
M13 Air purifier and frame	
M1068A3 only	
Replace	0779 00-1
M13 NBC Filter	
Mount Bracket	

INDEX, cont'd

<u>Subject</u>	<u>WP Sequence No.-Page No.</u>
M577A3	
Replacement.....	0803 00-1
Switch	
M577A3	
Replacement.....	0803 00-1
M13 NBC Filter switch	
M1068A3 only	
Replace.....	0805 00-1
M13 NBC Filters and Hoses	
Replace	0786 00-1
M13 NBC Filters and hoses	
M1068A3 only	
Replace.....	0789 00-1
M13 NBC Heater	
Wiring Harness	
M577A3	
Replacement.....	0808 00-1
M13 NBC heater hoses	
M1068A3 only	
Replace.....	0790 00-1
M13 NBC Heater wiring harness	
M1068A3 only	
Replace.....	0809 00-1
M13 NBC Heaters	
M1068A3	
Replacement.....	0798 00-1
M13 Orifice connector assembly, bracket, and quick coupling half	
M1068A3 only	
Replace	0781 00-1
M14 NBC Cables and switch assembly	
M1059A3	
Replacement.....	0799 00-1
M14 NBC Heater	
Wiring Harness	
(M113A3 Ambulance)	
Replace.....	0807 00-1
M3 NBC Heater	
Bracket	
M113A3	
Replacement.....	0791 00-1
Control box	
M113A3	
Replace.....	0791 00-1

INDEX, cont'd

<u>Subject</u>	<u>WP Sequence No.-Page No.</u>
Regulator	
M113A3	
Replacement.....	0791 00-1
Wiring Harness (M1059A3)	
Replace.....	0806 00-1
M3 NBC Heater Control Box	
M577A3	
Replacement.....	0792 00-1
M3 NBC Heater control box	
M1068A3	
Replacement.....	0793 00-1
M3 NBC Heater Hoses and Fittings (M113A3 Ambulance)	
Replace	0784 00-1
M3 NBC Heaters and Controllers	
M113A3 Ambulances	
Replacement.....	0795 00-1
M3 NBC Hoses and Fittings	
Replace	0788 00-1
M43 Unit Interface Wiring Harnesses	
Chemical Alarm	
M113A3	
Replacement.....	0923 00-1
M8A3 NBC Cables, Switch Assembly, and Brackets	
M577A3	
Replacement.....	0801 00-1
M8A3 NBC Hoses and Brackets	
Replace.....	0785 00-1, 0787 00-1
M8A3/M14 Orifice connector assembly, support, and quick coupling half	
M113A3, M1059A3, and M577A3 only	
Replace.....	0780 00-1
M8A3/M3 NBC Filter	
Switch Assembly (M1059A3)	
Replace.....	0804 00-1
Machine gun mount	
Commander's cupola	
M113A3, M1059A3, M58, and M1064A3	
Repair	0498 00-1
Replacement.....	0497 00-1
Machine gun mount stops	
Commander's cupola	
M1059A3	
Replacement.....	0499 00-1
Main light switch	

INDEX, cont'd

<u>Subject</u>	<u>WP Sequence No.-Page No.</u>
Replacement	0283 00-1
Maintenance Allocation Chart (MAC)	0925 00-1
Malfunction/Symptom Index	0006 00-1
Map Board	
M1068A3	
Replacement	0618 00-1
M577A3	
Replacement	0580 00-1
Map Storage Box	
M1068A3	
Repair	0620 00-1
Replacement	0619 00-1
Master switch	
M113A3 , M1059A3, M1064A3, and M58 only	
Replacement	0262 00-1
Master switch on indicator doesn't light	0048 00-1
Master switch panel	
M113A3 , M1059A3, M1064A3, and M58	
Replacement	0260 00-1
M577A3 and M1068A3 only	
Replacement	0261 00-1
Master switch panel dome lights lead assembly	
M577A3 and M1068A3	
Replacement	0380 00-1
Master switch to auxiliary power receptacle lead (circuit 50)	
M113A3 , M1059A3, M1064A3, and M58	
Replacement	0268 00-1
Master switch to distribution box lead (circuit 49)	
M113A3 , M1059A3, M1064A3, and M58 only	
Replacement	0266 00-1
M577A3 and M1068A3 only	
Replacement	0267 00-1
Materials and Expendable Supplies List	0928 00-1
Meters	
Power Control Enclosure AC and DC	
M1068A3	
Replacement	0827 00-1
Modulator	
Throttle valve (TV)	
Replacement	0218 00-1
Mortar hatch covers	
M1064A3	
Replacement	0482 00-1

INDEX, cont'd

<u>Subject</u>	<u>WP Sequence No.-Page No.</u>
Mortar hatch exterior catches and bumpers	
M1064A3	
Replacement.....	0480 00-1
Mortar hatch interior release mechanisms	
M1064A3	
Replacement.....	0481 00-1
Mount	
Dome light	
M577A3 and M1068A3	
Repair.....	0312 00-1
Driver's Hatch Night Vision	
M58	
Replacement.....	0537 01-1
Fire Extinguisher	
M1059A3	
Replacement.....	0896 00-1
Fire Extinguisher, Portable	
All Except M1068A3	
Replacement.....	0895 00-1
M1068A3	
Replacement/Repair	0897 00-1
M1068A3	
Replacement.....	0834 00-1
Shock absorber	
Replacement.....	0436 00-1
Track tension adjuster	
Replacement.....	0419 00-1
Mount and Bracket	
APIU Rack	
M1068A3	
Replacement.....	0813 00-1
Mount Bracket	
M13 NBC Filter	
M577A3	
Replacement.....	0803 00-1
Water/Ration Heater	
(M113A3 Only)	
Replace.....	0811 00-1
Mounting	
Pamphlet bag	
Repair	0442 00-1
Mounting Blocks	

INDEX, cont'd

<u>Subject</u>	<u>WP Sequence No.-Page No.</u>
Fuel Valve	
All Except M577A3 and M1068A3	
Replacement.....	0199 00-1
Mounting Bracket	
Commander's Display (DVE)	
M58	
Replacement.....	0866 06-1
Driver's Display (DVE)	
M58	
Replacement.....	0866 02-1
Glow Plug Controller	
Replacement.....	0212 00-1
Mounting Bracket, and Switch	
NBC Orifice Connector Assembly	
M58	
Replacement.....	0916 00-1
Mounts	
Transmission	
Replacement.....	0385 00-1
Mounts and Ground Lead	
Instrument Panel	
All Except M58	
Replacement.....	0295 00-1
M58	
Replacement.....	0295 01-1
Mounts, Engine	
Replace.....	0158 00-1
Muffler	
Bracket	
Replace.....	0224 00-1
Muffler Extension and Cap	
Replacement.....	0223 00-1
N	
NATO Auxiliary power (slave) receptacle	
M577A3 and M1068A3 only	
Replacement.....	0264 00-1
NBC	
Air Purifier and Frame	
M113A3	
Replace.....	0775 00-1
M58	
Replacement.....	0914 00-1
Cable Assembly	

INDEX, cont'd

<u>Subject</u>	<u>WP Sequence No.-Page No.</u>
M58	
Removal/Installation	0917 00-1
Cable to Heaters, Air Purifier, and Switch	
M113A3	
Replacement.....	0800 00-1
Hose Assemblies	
M58	
Removal/Installation	0915 00-1
NBC Brackets	
M8A3	
M577A3	
Replacement.....	0801 00-1
NBC Cables	
M8A3	
M577A3	
Replacement.....	0801 00-1
NBC Filter	
Mount Bracket	
M577A3	
Replacement.....	0803 00-1
Switch	
Replacement.....	0803 00-1
Switch Assembly	
M113A3 and M113A3 Ambulance	
Replacement.....	0802 00-1
NBC Filter switch	
M13	
M1068A3 only	
Replace.....	0805 00-1
NBC Filters and hoses	
M13	
M1068A3 only	
Replace.....	0789 00-1
NBC Heater	
Hoses and Fittings	
Replace.....	0782 00-1
NBC Heater Control Box	
M3	
M577A3	
Replacement.....	0792 00-1
NBC Heater control box	
M3	
M1068A3	

INDEX, cont'd

<u>Subject</u>	<u>WP Sequence No.-Page No.</u>
Replacement.....	0793 00-1
NBC Heater Hoses and Fittings	
Replace	0782 00-1
NBC Heater wiring harness	
M13	
M1068A3 only	
Replace.....	0809 00-1
NBC Heaters	
M13	
M1068A3	
Replacement.....	0798 00-1
NBC Heaters and Controllers	
M113A3	
Replacement.....	0794 00-1
M3	
M113A3 Ambulances	
Replacement.....	0795 00-1
NBC kit	
M14	
Air purifier and frame (M113A3)	
Replace.....	0774 00-1
M8A3	
Air purifier and frame with M3 heater kit (M1059A3)	
Replace.....	0778 00-1
NBC Air purifier and frame (M1059A3)	
Replace.....	0777 00-1
M8A3/M13	
Air purifier and frame (M577A3)	
Replace.....	0776 00-1
NBC Kits	
NBC Heaters and Mounts	
M1059A3	
Replacement.....	0797 00-1
M577A3	
Replacement.....	0796 00-1
NBC Orifice Connector Assembly	
Mounting Bracket, and Switch	
M58	
Replacement.....	0916 00-1
NBC Orifice Connector Assembly, Mounting Bracket, and Switch	
M58	
Replacement.....	0916 00-1
NBC Switch Assembly	

INDEX, cont'd

<u>Subject</u>	<u>WP Sequence No.-Page No.</u>
M8A3	
M577A3	
Replacement.....	0801 00-1
Night vision guard	
Driver's Hatch	
M58	
Replacement.....	0536 01-1
Night vision mount	
Driver's Hatch	
M58	
Replacement.....	0537 01-1
No AC power from inverters	
M1068A3 only	0109 00-1
No AC power from tent interface panel A5	
M1068A3 only	0091 00-1
No AC/DC input to ATCCS UPS power box	
M1068A3 only	0100 00-1
No data output from data panel A12	
M1068A3 only	0110 00-1
No data output from data panel A13	
M1068A3 only	0112 00-1
No DC output from DC power supply	
M1068A3 only	0108 00-1
No DC power from tent interface panel A5	
M1068A3 only	0092 00-1
No DC power to single point LAN ground box A15	
M1068A3 only	0097 00-1
No exterior lights operate	0029 00-1
No LAN output from data panel A12	
M1068A3 only	0111 00-1
No LAN output from data panel A13	
M1068A3 only	0113 00-1
No power from curbside AC power extension box A7	
M1068A3 only	0094 00-1
No power from curbside UPS power extension box A19	
M1068A3 only	0099 00-1
No power from DC power extension box A9 (all except jack J23)	
M1068A3 only	0095 00-1
No power from DC power extension box A9, jack J23 (JTIDS)	
M1068A3 only	0096 00-1
No power from roadside AC power extension box A6	
M1068A3 only	0093 00-1
No power from UPS power extension box A18	

INDEX, cont'd

<u>Subject</u>	<u>WP Sequence No.-Page No.</u>
M1068A3 only	0098 00-1
No power to AC circuits	
M1068A3 only	0107 00-1
No power to DC circuits	
M1068A3 only	0106 00-1
Nomenclature Cross-Reference List.....	0001 00-10
Non-skid plates	
M1064A3	
Replacement.....	0738 00-1
O	
Oil	
Cooler hoses, fittings, and mounting	
Transmission	
Replacement.....	0399 00-1
Filter element, engine, Replace.....	0165 00-1
Gauge rod/tube, engine, Replace.....	0164 00-1
Oil and Oil Filter Element	
Transmission	
Replacement.....	0398 00-1
Oil can bracket	
Replacement.....	0574 00-1
Oil drain tubes and bracket	
Transmission	
Replacement.....	0384 00-1
Oil high temperature switch	
Transmission	
Replacement.....	0322 00-1
Oil low pressure transmitter and hardware	
Engine	
Replacement.....	0320 00-1
Oil seal	
Differential	
Final drive	
Replacement.....	0404 00-1
Final drive differential	
Replacement.....	0404 00-1
Oil Tank Module	
Fog	
M1059A3	
Replacement.....	0753 00-1
On cargo hatch cover	
Spall liner	
M113A3	

INDEX, cont'd

<u>Subject</u>	<u>WP Sequence No.-Page No.</u>
Replacement.....	0509 00-1
On ramp	
Spall liner	
M113A3	
Replacement.....	0512 00-1
On ramp door	
Spall liner	
M113A3	
Replacement.....	0511 00-1
On-off switches	
Instrument panel	
Replacement.....	0282 00-1
Operator's Intercommunication Set Cable	
M58	
Replacement.....	0894 00-1
Operator's Seat	
M1059A3	
Replacement/Repair.....	0567 00-1
Orifice connector assembly	
M8A3/M14	
M113A3, M1059A3, and M577A3 only	
Replace.....	0780 00-1
Orifice connector assembly, support, and quick coupling half	
M8A3/M14	
M113A3, M1059A3, and M577A3 only	
Replace.....	0780 00-1
Orifice connector support	
M8A3/M14	
M113A3, M1059A3, and M577A3 only	
Replace.....	0780 00-1
Orifice support quick coupling half	
M8A3/M14	
M113A3, M1059A3, and M577A3 only	
Replace.....	0780 00-1
Outlet Tube and Hoses	
Radiator	
Replacement.....	0233 00-1
P	
Pad	
Cushioning	
Replacement.....	0570 00-1
Track shoe	
Replacement.....	0424 00-1

INDEX, cont'd

<u>Subject</u>	<u>WP Sequence No.-Page No.</u>
Pamphlet bag mounting	
Repair	0442 00-1
Panel	
A13, Roadside Data	
M1068A3	
Replacement.....	0835 00-1
Master switch	
M113A3, M1059A3, M1064A3, and M58	
Replacement.....	0260 00-1
M577A3 and M1068A3 only	
Replacement.....	0261 00-1
Warning Light	
All Except M58	
Replacement.....	0292 00-1
Warning light assembly	
All Except M58	
Replacement.....	0291 00-1
Panel Assembly	
Instrument	
All Except M58	
Replacement.....	0279 00-1
M58	
Replacement.....	0279 01-1
Panel lights	
Replacement	0286 00-1
Parking brake	
Adjustment	0408 00-1
Parking brake bracket	
Replacement	0331 00-1
Parking brake control cable assembly	
Replacement	0411 00-1
Parking brake control lever assembly	
Replacement	0412 00-1
Parking brake indicator malfunctions.....	0052 00-1
Parking brake switch	
Replacement	0331 00-1
Pedal	
Accelerator, Lower	
Replacement.....	0215 00-1
Service brake	
Upper and lower	
Replacement.....	0409 00-1
Pedal Assembly	

INDEX, cont'd

<u>Subject</u>	<u>WP Sequence No.-Page No.</u>
Accelerator, Upper	
Replacement.....	0216 00-1
Personnel Heater	
Control Box Bracket	
M1068A3	
Replacement.....	0617 00-1
Duct	
Repair.....	0707 00-1
Duct and Hoses	
Replacement.....	0706 00-1
Intercom Box Bracket	
M1068A3	
Replacement.....	0617 00-1
Personnel heater	
Fuel filter	
Bracket M113A3, M1059A3, and M58	
Replacement.....	0698 00-1
M113A3, M1059A3, and M58	
Replacement.....	0698 00-1
Fuel pump	
M1064A3	
Replacement.....	0697 00-1
M577A3 and M1068A3	
Replacement.....	0696 00-1
Fuel pump hose	
M113A3, M1059A3, and M58	
Replacement.....	0689 00-1
Fuel pump to bulkhead connection hose	
M577A3 AND M1068A3	
Replacement.....	0692 00-1
Fuel pump to fuel shutoff valve hose	
M1064A3	
Replacement.....	0694 00-1
Personnel Heater Assembly	
All Except M1064A3	
Replacement.....	0703 00-1
M1064A3	
Replacement.....	0704 00-1
Repair	0705 00-1
Personnel Heater Fuel Filter	
Service	0680 00-1
Personnel Heater Fuel Pump	
M113A3, M1059A3, and M58	

INDEX, cont'd

<u>Subject</u>	<u>WP Sequence No.-Page No.</u>
Replacement.....	0695 00-1
Service	0681 00-1
Personnel Heater Fuel Tube	
All Except M1064A3	
Replacement.....	0686 00-1
Personnel heater malfunctions	0086 00-1
Personnel Seats, backrests, cushions and belts	
M1059A3	
Replacement.....	0549 00-1
M1064A3	
Replacement.....	0550 00-1
Personnel seats, cushions, and belts	
M113A3	
Replacement.....	0546 00-1
M577A3	
Replacement.....	0547 00-1
Phone extension box A14 post(s) inoperative	
M1068A3 only	0114 00-1
Pin	
Shock absorber	
Replacement.....	0437 00-1
Pintle	
Towing	
Repair	0434 00-1
Replacement.....	0433 00-1
Pipes	
Coolant Heater Exhaust	
Replacement.....	0724 00-1
Front Bilge Pump	
Replace.....	0631 00-1
Rear Bilge Pump	
Replacement.....	0634 00-1
Plate	
Smoke grenade launcher	
M113A3 and M1059A3 only	
Replacement.....	0455 00-1
Plates	
Non-skid	
M1064A3	
Replacement.....	0738 00-1
Platform	
Commander's	
M113A3, M1059A3, M1064A3, and M58	

INDEX, cont'd

<u>Subject</u>	<u>WP Sequence No.-Page No.</u>
Replacement/repair	0559 00-1
M577A3 and M1068A3	
Replacement/Repair	0564 00-1
Plug	
Hull drain	
Replacement	0451 00-1
Portable Fire Extinguisher Mount	
All Except M1068A3	
Replacement	0895 00-1
M1068A3	
Replacement/Repair	0897 00-1
Post	
Commander's	
M113A3, M1059A3, and M58	
Replacement	0560 00-1
M577A3 and M1068A3	
Replacement/Repair	0564 00-1
Commander's seat	
M1064A3	
Replacement	0561 00-1
Post Assembly	
Driver's Seat	
Replacement	0556 00-1
M113A3	
Replacement	0742 00-1, 0743 00-1
Power Cable	
Chemical Alarm	
M113A3	
Replacement	0919 00-1
DVE Sensor Set Assembly	
M58	
Replacement	0866 01-1
Water/Ration Heater	
(M113A3 Only)	
Replace	0810 00-1
Power cable	
Intervehicle	
M577A3 and M1068A3	
Replacement	0381 00-1
Power Control Enclosure	
AC and DC Light Indicators	
M1068A3	
Replacement	0827 00-1

INDEX, cont'd

<u>Subject</u>	<u>WP Sequence No.-Page No.</u>
AC and DC Meters	
M1068A3	
Replacement.....	0827 00-1
Bracket	
M1068A3	
Repair.....	0828 00-1
Circuit 44A Lead	
M1068A3	
Replacement.....	0829 00-1
Faceplate	
M1068A3	
Repair.....	0828 00-1
Power control enclosure A1 DC input/output inoperative	
M1068A3 only	0090 00-1
Power Control Enclosure Assembly	
A1	
M1068A3	
Replacement.....	0826 00-1
Power Distribution Box A3	
M1068A3	
Replacement/Repair	0831 00-1
Power Distribution Cable (W3)	
M1068A3	
Replacement.....	0837 00-1
Power Entry Box Assembly A4	
M1068A3	
Replacement.....	0832 00-1
Power Extension	
Box A18, AC	
M1068A3	
Replacement.....	0836 00-1
Power Extension Box A18 and Bracket	
M1068A3	
Replacement.....	0836 00-1
Power Harness	
Glow Plug	
Replacement.....	0211 00-1
Power Plant	
Block	0157 00-1
Hydraulic Hoses	
Replacement.....	0668 00-1

INDEX, cont'd

<u>Subject</u>	<u>WP Sequence No.-Page No.</u>
Power plant access panel	
Driver's	
Replacement.....	0441 00-1
Power plant assembly	
Removal/Installation	0156 00-1
Power plant bottom access cover	
Replacement.....	0450 00-1
Power plant door	
All except M113A3	
Replacement.....	0471 00-1
M113A3	
Replacement.....	0470 00-1
Repair.....	0472 00-1
Power plant door combat lock	
Replacement.....	0473 00-1
Power plant grill screen	
Replacement.....	0468 00-1
Power plant grill support arm	
Replacement.....	0467 00-1
Power plant grille	
Raise and lower.....	0464 00-1
Removal/installation.....	0465 00-1
Power plant rear access panels	
Repair/Replacement	0439 00-1
Power Plant Sling	
Inspect	0673 00-1
Power Supply	
Storage Box Assembly	
M1068A3	
Replacement/Repair	0824 00-1
Power supply	
Solid state infrared	
Replacement.....	0297 00-1
Power Supply Cable	
Driver's Vision Enhancer (DVE) AN/VAS-5	
M58	
Replacement.....	0866 04-1
Power supply cable assembly	
Driver's night vision (DNV) (AN/VVS-2)	
All Except M58	
Replacement.....	0368 00-1
Pressure switch	
Differential	

INDEX, cont'd

<u>Subject</u>	<u>WP Sequence No.-Page No.</u>
Bypass plug	
Replacement.....	0401 00-1
Transmission oil	
Replacement.....	0400 00-1
Preventive Maintenance Checks and Services (PMCS), Including Lubrication Instructions	
Annual	0155 00-1
Semi-Annual.....	0155 00-1
Principles of Operation	
Auxiliary Automotive System.....	0003 00-2
Special Equipment.....	0003 00-3
Winterization Equipment	0003 00-3
Printer Mount	
Replace/Repair	0823 00-1
Propeller shaft and universal joints	
Replacement.....	0405 00-1
Pulley	
Coolant Pump Idler	
Replacement.....	0240 00-1
Ventilating Fan Drive	
Replacement.....	0244 00-1
Pulse Tachometer	
STE/ICE	
Replacement.....	0867 00-1
Pump	
Coolant Heater	
Replacement.....	0731 00-1
Engine Coolant	
Replacement.....	0241 00-1
Hydraulic	
Ramp	
Replacement.....	0655 00-1
Pump Assembly	
Fog Oil	
(M1059A3 Only)	
Replace.....	0763 00-1
Pump Unit	
Coolant Heater	
Replace.....	0728 00-1
Push-pull control assembly, bracket, links, and pins (cable-activated lock)	
Replacement.....	0429 00-1

INDEX, cont'd

<u>Subject</u>	<u>WP Sequence No.-Page No.</u>
Q	
Quick coupling half	
M13 Orifice	
M1068A3 only	
Replace.....	0781 00-1
M8A3/M14 Orifice support	
M113A3, M1059A3, and M577A3 only	
Replace.....	0780 00-1
Quick release pin and lanyard	
Replacement.....	0431 00-1
Quick release pins and plates	
Spall liner	
M113A3	
Repair.....	0506 00-1
R	
Rack	
Radio	
M58	
Replace.....	0891 00-1
Radio stowage	
M1064A3	
Replacement.....	0609 00-1
Rifle	
M1064A3	
Replacement.....	0612 00-1
Rack Assembly	
Rack Base	
Right Side	
M1068A3	
Replacement.....	0622 00-1
Racks	
Left Bulkhead Radio Stowage	
M577A3 and M1068A3	
Replacement.....	0577 00-1
Radiac wire harness	
M113A3, M577A3, and M1068A3	
Replacement.....	0376 00-1
Radiator	
Clean	0228 00-1
Radiator access door	
Replacement.....	0469 00-1
Radiator and Parts	
Replacement.....	0229 00-1

INDEX, cont'd

<u>Subject</u>	<u>WP Sequence No.-Page No.</u>
Radiator Outlet Tube and Hoses	
Replacement	0233 00-1
Radio Operator's Seat	
M1068A3 and M58	
Replacement/Repair	0568 00-1
Radio Rack	
M58	
Replace	0891 00-1
Radio Stowage Rack	
Right Front	
M577A3	
Replacement	0579 00-1
Radio Stowage Racks	
Left Bulkhead	
M577A3 and M1068A3	
Replacement	0577 00-1
Radio(s) don't work	0044 00-1
Ramp	
Bracket	
M113A3, M577A3, and M1068A3	
Replacement	0516 00-1
Control Valve	
Elbow	
Replacement	0663 00-1
Hose	
Replacement	0663 00-1
Replacement	0660 00-1
Control Valve (with Internal Relief Valve) and Fittings	
Replacement	0661 00-1
Control Valve and Fittings (with External Relief Valve)	
Replacement	0659 00-1
Cylinder	
Replacement	0656 00-1
Cylinder Breather Hose	
All Except M1064A3	
Replacement	0666 00-1
M1064A3	
Replacement	0667 00-1
Door	
Stop Bracket	
Replacement	0517 00-1
External Relief Valve	
Replacement	0660 00-1

INDEX, cont'd

<u>Subject</u>	<u>WP Sequence No.-Page No.</u>
Fittings with Ramp Control Valve (Internal Relief Valve)	
Replacement.....	0660 00-1
Hose	
Bulkhead to Cylinder	
Replacement.....	0665 00-1
Hydraulic Pump	
Replacement.....	0655 00-1
Linkage	
M1064A3	
Replacement.....	0528 00-1
M113A3 and M1059A3	
Replacement.....	0526 00-1
M577A3 and M1068A3	
Replacement.....	0527 00-1
Lock	
M1064A3	
Adjustment.....	0523 00-1
M113A3 and M1059A3	
Adjustment.....	0521 00-1
M577A3 and M1068A3	
Adjustment.....	0522 00-1
Vision Port and Shield	
M58	
Replacement/Repair.....	0586 00-1
Ramp Door	
Handles	
Replacement.....	0519 00-1
Hook	
Replacement.....	0518 00-1
Seal	
Replacement.....	0520 00-1
Shaft	
Replacement.....	0519 00-1
Spring	
Replacement.....	0518 00-1
Ramp door switch and mount	
M577A3 and M1068A3	
Replacement.....	0335 00-1
Ramp drain plugs	
Replacement.....	0515 00-1

INDEX, cont'd

<u>Subject</u>	<u>WP Sequence No.-Page No.</u>
Ramp Lock	
Handle and Arms	
All Except M577A3 and M1068A3	
Replacement.....	0524 00-1
Lever and Cable	
M577A3 and M1068A3	
Replacement.....	0525 00-1
Ramp operation is slow or sluggish.....	0083 00-1
Ramp seal	
Replacement.....	0514 00-1
Ramp will not lower	0082 00-1
Ramp will not raise or free falls	0084 00-1
Range controller	
Bracket	
Used with solenoid-activated steering lock	
Replacement.....	0386 00-1
Transmission	
Used with cable-activated steering lock	
Replacement.....	0387 00-1
Used with solenoid-activated steering lock	
Replacement.....	0386 00-1
Range controller lamp	
Transmission	
Replacement.....	0388 00-1
Range controller switch	
Transmission	
Replacement.....	0389 00-1
Rear access panels	
Power plant	
Repair/Replacement.....	0439 00-1
Rear Armor	
M113A3	
Replacement.....	0751 00-1
Rear Bilge Pump	
Replacement.....	0635 00-1
Strainer	
Replacement.....	0635 00-1
Rear Bilge Pump Pipes	
Replacement.....	0634 00-1
Rear compartment air ventilator	
Replacement.....	0454 00-1

INDEX, cont'd

<u>Subject</u>	<u>WP Sequence No.-Page No.</u>
Rear dome light switch	
M577A3 and M1068A3	
Replacement.....	0315 00-1
Rear external stowage frame	
M1068A3	
Replacement.....	0626 00-1
Rear main wiring harness	
M1064A3	
Replacement.....	0364 00-1
M1068A3	
Replacement.....	0365 00-1
M113A3, M1059A3, and M58	
Replacement.....	0362 00-1
M577A3	
Replacement.....	0363 00-1
Rear tiedown plates	
Replacement.....	0445 00-1
Rear upper hull spall liner	
M113A3	
Replacement.....	0510 00-1
Rear utility outlet receptacles	
M577A3 and M1068A3	
Replacement.....	0378 00-1
Rear utility receptacle circuit breakers	
M577A3 and M1068A3 only	
Replacement.....	0276 00-1
Receptacle	
Auxiliary power (slave)	
M113A3 , M1059A3, M1064A3, and M58 only	
Replacement.....	0263 00-1
NATO Auxiliary power (slave)	
M577A3 and M1068A3 only	
Replacement.....	0264 00-1
Receptacles	
Rear utility outlet	
M577A3 and M1068A3	
Replacement.....	0378 00-1
Reel holder assembly	
Cable	
M1064A3	
Repair.....	0604 00-1

INDEX, cont'd

<u>Subject</u>	<u>WP Sequence No.-Page No.</u>
Reel holder assembly, cable	
M1064A3	
Replacement.....	0603 00-1
References	0924 00-1
Refill Tray Bracket	
Chemical Alarm	
M113A3	
Replacement.....	0922 00-1
Regulator	
Voltage	
Adjustment.....	0256 00-1
Regulator assembly	
Replacement.....	0257 00-1
Release	
Trim vane	
Repair	0463 00-1
Replacement.....	0462 00-1
Release mechanisms	
Mortar hatch interior	
M1064A3	
Replacement.....	0481 00-1
Restriction indicator	
Air cleaner	
Replace.....	0171 00-1
Retainer	
Batteries	
M1064A3	
Replacement.....	0349 00-1
Repair Parts, Special Tools, TMDE, and Support Equipment.....	0004 00-1
Rifle Brackets	
Replacement.....	0573 00-1
Rifle Rack	
M1064A3	
Replacement.....	0612 00-1
Right Equipment Rack	
Brackets and Mounts	
M1068A3	
Replacement.....	0814 00-1
Right Forward Table	
M577A3	
Replacement.....	0581 00-1
Right front armor plate	
Replacement.....	0448 00-1

INDEX, cont'd

<u>Subject</u>	<u>WP Sequence No.-Page No.</u>
Right Front Radio Stowage Rack	
M577A3	
Replacement.....	0579 00-1
Right headlight wiring harness	
Replace	0373 00-1
Right rear utility outlet/admittance buzzer works improperly	
M577A3 and M1068A3 only	0042 00-1
Right Rearward Table	
M577A3	
Replacement.....	0582 00-1
Right Side Base Extension	
M1068A3	
Replacement.....	0623 00-1
Right side spall liners	
M113A3	
Replacement.....	0504 00-1
Right stop light - tail light	
M577A3	
Replacement.....	0301 00-1
Repair.....	0302 00-1
Road wheel	
T130	
Replacement.....	0426 00-1
T150	
Replacement.....	0426 01-1
Road wheel hub	
Replacement.....	0416 00-1
Road wheel support arm, bearings, and seals	
Replacement.....	0415 00-1
Roadside Data Panel A13	
M1068A3	
Replacement.....	0835 00-1
S	
Safety pin stowage block	
Commander's cupola	
M113A3, M1059A3, M58, and M1064A3	
Replacement.....	0495 00-1
Safety Relief Valve	
Fittings	
Replacement.....	0662 00-1
Hose	
Replacement.....	0662 00-1

INDEX, cont'd

<u>Subject</u>	<u>WP Sequence No.-Page No.</u>
Tube	
Replacement.....	0662 00-1
Sampling valve	
Transmission oil	
Replacement.....	0400 00-1
Schematic	
All except M577A3 and M1068A3	
Engine fuel system.....	0009 00-1
Bilge pump.....	0078 00-1
Coolant heater.....	0087 00-1
Engine charging system.....	0007 00-1
Engine starter circuit.....	0011 00-1
Indicators.....	0046 00-1
STE/ICE.....	0136 00-1
Electrical.....	0027 00-1
(cable-activated lock)	
Steering lock.....	0075 00-1
Engine air box heater.....	0013 00-1
M577A3 and M1068A3	
Engine fuel system.....	0010 00-1
Personnel heater.....	0085 00-1
Ramp.....	0081 00-1
(solenoid-activated lock)	
Steering lock.....	0074 00-1
Transmission.....	0060 00-1
Seal	
Ramp	
Replacement.....	0514 00-1
Ramp Door	
Replacement.....	0520 00-1
Seals	
Cargo hatch	
M113A3 and M1059A3	
Replacement.....	0478 00-1
Idler wheel arm	
Replacement.....	0418 00-1
Road wheel support	
Replacement.....	0415 00-1
Seat	
Commander's	
M1064A3	
Replacement.....	0561 00-1

INDEX, cont'd

<u>Subject</u>	<u>WP Sequence No.-Page No.</u>
M1068A3	
Replacement/repair	0566 00-1
M113A3, M1059A3, and M58	
Replacement.....	0560 00-1
M113A3, M1059A3, M1064A3, and M58	
Repair	0562 00-1
Commander's Jump	
M113A3	
Replacement.....	0563 00-1
Driver's	
Post assembly	
Repair	0557 00-1
Repair	0552 00-1
Replacement.....	0551 00-1
Operator's	
M1059A3	
Replacement/Repair	0567 00-1
Personnel	
M1059A3	
Replacement.....	0549 00-1
M1064A3	
Replacement.....	0550 00-1
Radio Operator's	
M58	
Replacement/Repair	0568 00-1
Seats	
Personnel	
M113A3	
Replacement.....	0546 00-1
M577A3	
Replacement.....	0547 00-1
Sensors	
Switches	
Replace.....	0321 01-1
Sensor Set Assembly Adapter	
AN/VAS-5 Driver's Night Vision Enhancer (DVE)	
M58	
Replacement.....	0866 05-1
Service and infrared headlights	
Repair	0304 00-1
Replacement	0303 00-1
Service and/or black out stop lights malfunction	0033 00-1
Service and/or parking brake won't hold carrier.....	0064 00-1

INDEX, cont'd

<u>Subject</u>	<u>WP Sequence No.-Page No.</u>
Service brake control linkage	
Adjustment	0407 00-1
Replacement	0410 00-1
Service brake pedal	
Upper and lower	
Replacement	0409 00-1
Service headlights don't work	0031 00-1
Service tallight doesn't work	0035 00-1
Service Upon Receipt	0154 00-1
Shaft	
Fuel Control	
Replacement	0217 00-1
Shelf Assembly	
Right Side	
M1068A3	
Replacement	0621 00-1
Shield	
External Handle	
M1064A3	
Replacement	0903 00-1
M113A3 and M1059A3	
Replacement	0901 00-1
M577A3 and M1068A3	
Replacement	0902 00-1
Ramp Vision Port	
M58	
Replacement/Repair	0586 00-1
Shields, Armor, Commander's Cupola	
M113A3 and M1064A3	
Replacement	0747 00-1
Shock absorber	
Replacement	0435 00-1
Shock absorber mount	
Replacement	0436 00-1
Shock absorber pin	
Replacement	0437 00-1
Shunt	
STE/ICE	
M1064A3	
Replacement	0873 00-1
M113A3 and M1059A3	
Replacement	0870 00-1

INDEX, cont'd

<u>Subject</u>	<u>WP Sequence No.-Page No.</u>
M577A3 and M1068A3 Replacement.....	0871 00-1
Shunt Guard	
STE/ICE	
M113A3 and M1059A3 Replacement.....	0868 00-1
Shut-off Valve Assembly	
Fuel	
M113A3, M1059A3, and M58 Replacement.....	0684 00-1
Side Armor	
M113A3 Replacement.....	0750 00-1
Signal Patch Panel Box A10 Replace	0816 00-1
Sling	
Power Plant	
Inspect	0673 00-1
Smoke Generator	
Adapter Access Plate to Generator Electrical Cable Assembly M1059A3 Replacement.....	0761 00-1
Breather Hose Assembly M1059A3 Replacement.....	0754 00-1
Control Panel Assembly M1059A3 Replace.....	0756 00-1
Internal Cable Assembly M1059A3 Replacement.....	0760 00-1
M1059A3 Replacement.....	0755 00-1
Power Supply Cable Assembly M1059A3 Replacement.....	0757 00-1
Support Bracket M1059A3 Replacement.....	0755 00-1
Smoke Generator (M1059A3)	
Adapter Access Plate	
Gasket	
Replace.....	0766 00-1

INDEX, cont'd

<u>Subject</u>	<u>WP Sequence No.-Page No.</u>
Adapter Access Plate to Cover Assembly Air Hose	
Replace.....	0768 00-1
Air Hose	
Compressor Reservoir to Access Plate	
Replace.....	0767 00-1
Armor	
Replace.....	0771 00-1
Fuel Can Lid Assembly	
Replace.....	0764 00-1
Fuel Filter	
Replace.....	0773 00-1
Fuel Lines and Guards	
Replace.....	0765 00-1
Glow Plug Cable Assembly	
Replace.....	0772 00-1
Water Separator	
Replace.....	0773 00-1
Smoke grenade launcher guard, plate, and base	
M113A3 and M1059A3 only	
Replacement.....	0455 00-1
Smoke grenade launcher wiring harness	
M113A3 , M1059A3, and M58	
Replacement.....	0366 00-1
Smoke grenade launcher(s) malfunction	
M113A3 and M1059A3	0045 00-1
Solenoid, bracket, links, and pins (solenoid-activated lock)	
Steering lock	
Replacement.....	0428 00-1
Solenoid-activated steering lock malfunctions	0076 00-1
Solid state infrared power supply	
Replacement.....	0297 00-1
Spall liner	
Rear upper hull	
M113A3	
Replacement.....	0510 00-1
Spall liner and bracket	
Forward	
M113A3	
Replacement.....	0507 00-1
Spall liner on cargo hatch cover	
M113A3	
Replacement.....	0509 00-1

INDEX, cont'd

<u>Subject</u>	<u>WP Sequence No.-Page No.</u>
Spall liner on ramp	
M113A3	
Replacement.....	0512 00-1
Spall liner on ramp door	
M113A3	
Replacement.....	0511 00-1
Spall liner quick release pins and plates	
M113A3	
Repair.....	0506 00-1
Spall liners	
Forward upper right and left side	
M113A3	
Replacement.....	0508 00-1
Left side	
M113A3	
Replacement.....	0505 00-1
Right side	
M113A3	
Replacement.....	0504 00-1
Special purpose cable	
Instrument panel	
Replacement.....	0290 00-1
Speedometer	
Cable	
Adapter	
Replace.....	0860 00-1
Replace.....	0860 00-1
Service.....	0858 00-1
Replace.....	0859 00-1
Speedometer Cable	
Repair.....	0861 00-1
Speedometer malfunctions.....	0115 00-1
Spring Tensioner	
Idler Arm	
Replacement.....	0246 00-1
Start switch	
Engine	
Replacement.....	0284 00-1
Starter	
Replace.....	0259 00-1
Starter relay switch	
Replacement.....	0258 00-1

INDEX, cont'd

<u>Subject</u>	<u>WP Sequence No.-Page No.</u>
STE/ICE	
Pulse Tachometer	
Replacement.....	0867 00-1
Shunt	
M1064A3	
Replacement.....	0873 00-1
M113A3 and M1059A3	
Replacement.....	0870 00-1
M577A3 and M1068A3	
Replacement.....	0871 00-1
Shunt Guard	
M113A3 and M1059A3	
Replacement.....	0868 00-1
STE/ICE Crew Wiring Harness	
M1064A3	
Replacement.....	0881 00-1
M113A3 and M1059A3	
Replacement.....	0878 00-1
M577A3 and M1068A3	
Replacement.....	0879 00-1
STE/ICE Distribution Box	
M1064A3	
Replacement.....	0877 00-1
M113A3 and M1059A3	
Replacement.....	0874 00-1
M577A3 and M1068A3	
Replacement.....	0875 00-1
STE/ICE Engine Wiring Harness	
Replacement.....	0882 00-1
STE/ICE test set to DCA 6	
Hook up.....	0117 00-1
Remove.....	0117 00-1
Steering	
Transmission	
Adjust.....	0393 00-1
Steering lock solenoid, bracket, links, and pins (solenoid-activated lock)	
Replacement.....	0428 00-1
Steering Lock Switch	
Replacement.....	0330 00-1
Steering Lock Switch Wiring Harness	
All Except M58	
Replacement.....	0367 00-1

INDEX, cont'd

<u>Subject</u>	<u>WP Sequence No.-Page No.</u>
M58	
Replacement.....	0367 01-1
Steering locked indicator malfunctions	0054 00-1
Steering support, brackets, and shaft	
Replacement.....	0432 00-1
Steering wheel linkage	
Adjustment.....	0427 00-1
Replacement.....	0430 00-1
Stencils	
M1059A3	0640 00-1
M1064A3	0641 00-1
M1068A3	0642 00-1
M113A3	0636 00-1
M577A3	0637 00-1
M58	0643 00-1
Stop light - tail light	
Left	
M577A3 and M1068A3	
Replacement.....	0299 00-1
Repair.....	0300 00-1
Right	
M577A3	
Replacement.....	0301 00-1
Repair.....	0302 00-1
Stop light - tail light and guards	
All Except M577A3 and M1068A3	
Replacement.....	0298 00-1
Stop switch	
Replacement.....	0332 00-1
Storage Box Assembly	
Power Supply	
M1068A3	
Replacement/Repair	0824 00-1
Stowage	
Driver's Night Vision (AN/VVS-2)	
All Except M58	
Replacement.....	0572 00-1
Stowage Box	
M113A3	
Replacement.....	0750 00-1

INDEX, cont'd

<u>Subject</u>	<u>WP Sequence No.-Page No.</u>
Stowage box	
Grenade	
M1064A3	
Replacement.....	0610 00-1
Periscope	
M1064A3	
Replacement.....	0611 00-1
Stowage Bracket	
AN/VAS-5 Driver's Vision Enhancer	
M58	
Replacement.....	0866 03-1
Track shoe.....	0575 01-1
Sight Extension Arm	
M1064A3	
Replacement.....	0613 00-1
Stowage Brackets for W1, W2, and NATO Slave Cables	
M1068A3 and M577A3	
Replacement.....	0626 01-1
Stowage frame	
Rear external	
M1068A3	
Replacement.....	0626 00-1
Stowage Rack	
Right Front Radio	
M577A3	
Replacement.....	0579 00-1
Stowage Racks	
Left Bulkhead Radio	
M577A3 and M1068A3	
Replacement.....	0577 00-1
Strainer	
Front Bilge Pump	
Replace.....	0632 00-1
Rear Bilge Pump	
Replacement.....	0635 00-1
Strainer Parts	
Filler Cap	
All Except M577A3 and M1068A3	
Replacement.....	0184 00-1
M577A3 and M1068A3	
Replacement.....	0185 00-1

INDEX, cont'd

<u>Subject</u>	<u>WP Sequence No.-Page No.</u>
Straps	
Webbing	
Replacement.....	0569 00-1
Support	
Antenna	
M58	
Replacement.....	0602 00-1
M8A3/M14 Orifice connector	
M113A3, M1059A3, and M577A3 only	
Replace.....	0780 00-1
Support, brackets, and shaft	
Steering	
Replacement.....	0432 00-1
Switch	
Blower	
M577A3 and M1068A3 only	
Replacement.....	0278 00-1
Differential Pressure	
Replacement.....	0401 00-1
Dome blackout light bypass	
M577A3 and M1068A3	
Replacement.....	0317 00-1
Engine start	
Replacement.....	0284 00-1
Flame Detector	
Adjust.....	0727 00-1
Flame Detetor	
Coolant Heater	
Replacement.....	0734 00-1
Front dome light	
M577A3 and M1068A3	
Replacement.....	0314 00-1
Fuel Filter Differential Pressure	
Replacement.....	0328 00-1
Fuel selector	
M577A3 and M1068A3 only	
Replacement.....	0277 00-1
Generator field pressure	
Replacement.....	0323 00-1
Headlight high beam selector	
Replacement.....	0333 00-1
Horn	
Replacement.....	0293 00-1

INDEX, cont'd

<u>Subject</u>	<u>WP Sequence No.-Page No.</u>
M58	
Replacement.....	0293 01-1
Light	
Main	
Replacement.....	0283 00-1
M13 NBC Filter	
M577A3	
Replacement.....	0803 00-1
Parking brake	
Replacement.....	0331 00-1
Rear dome Light	
M577A3 and M1068A3	
Replacement.....	0315 00-1
Rear dome light	
M577A3 and M1068A3	
Replacement.....	0315 00-1
Starter relay	
Replacement.....	0258 00-1
Steering lock	
Replacement.....	0330 00-1
Stop	
Replacement.....	0332 00-1
Thermostatic Fan Speed	
Replacement.....	0231 00-1
Transmission Oil	
Replacement.....	0400 00-1
Transmission oil high temperature	
Replacement.....	0322 00-1
Transmission range controller	
Replacement.....	0389 00-1
Switch and buzzer	
Admittance	
M577A3 and M1068A3	
Replacement.....	0334 00-1
Switch and mount	
Ramp door	
M577A3 and M1068A3	
Replacement.....	0335 00-1
Switch Assembly	
M8A3/M3 NBC Filter (M1059A3)	
Replace.....	0804 00-1

INDEX, cont'd

<u>Subject</u>	<u>WP Sequence No.-Page No.</u>
NBC Filter	
M113A3 and M113A3 Ambulance	
Replacement.....	0802 00-1
Switch to gauge lead	
Fuel select	
All Except M577A3 and M1068A3	
Replacement.....	0281 00-1
Switches	
On-off	
Instrument panel	
Replacement.....	0282 00-1
T	
Table	
Left	
M577A3	
Replacement.....	0578 00-1
Right forward	
M577A3	
Replacement.....	0581 00-1
Right Rearward	
M577A3	
Replacement.....	0582 00-1
Tachometer	
Cable	
Repair.....	0865 00-1
Replace.....	0864 00-1
Service.....	0858 00-1
Engine adapter	
Replace.....	0863 00-1
Pulse	
STE/ICE	
Replacement.....	0867 00-1
Replace	0862 00-1
Tachometer malfunctions	0116 00-1
Taillight	
Bracket	
M1068A3	
Repair	0625 00-1
Replacement.....	0625 00-1
Wiring Harness	
M1068A3	
Repair	0625 00-1
Replacement.....	0625 00-1

INDEX, cont'd

<u>Subject</u>	<u>WP Sequence No.-Page No.</u>
Tank	
Auxiliary	
Replacement.....	0230 00-1
Tank Module	
Fog Oil	
M1059A3	
Replacement.....	0753 00-1
Teleposts and cover	
Replacement.....	0296 00-1
Tent	
Frame mounts	
M577A3	
Replacement.....	0628 00-1
M577A3	
Replacement.....	0627 00-1
Tent Interface Panel	
Box Assembly A5	
M1068A3	
Replacement.....	0833 00-1
Tent Light Assembly	
M577A3 and M1068A3	
Replacement.....	0318 00-1
Terminal Blocks TB1 and TB2	
Inverter Housing A2	
M1068A3	
Replacement.....	0830 00-1
Terminals and leads	
Battery	
M113A3 and M1059A3	
Replacement.....	0340 00-1
M577A3 and M1068A3	
Replacement.....	0341 00-1
M58	
Replacement.....	0345 00-1
Terminals and leads (left side)	
Battery	
M1064A3	
Replacement.....	0343 00-1
Terminals and leads (right side)	
Battery	
M1064A3	
Replacement.....	0344 00-1

INDEX, cont'd

<u>Subject</u>	<u>WP Sequence No.-Page No.</u>
Test 10 diagnostic troubleshooting	
STE/ICE	0140 00-1
Test 10 engine RPM	
STE/ICE	0118 00-1
Test 11 diagnostic troubleshooting	
STE/ICE	0140 00-1
Test 12 diagnostic troubleshooting	
STE/ICE	0140 00-1
Test 13 diagnostic troubleshooting	
STE/ICE	0140 00-1
Test 24 fuel supply pressure	
STE/ICE	0119 00-1
Test 24 fuel supply pressure diagnostic troubleshooting	
STE/ICE	0143 00-1
Test 25 fuel return pressure	
STE/ICE	0120 00-1
Test 25 fuel return pressure diagnostic troubleshooting	
STE/ICE	0144 00-1
Test 26 fuel filter pressure drop	
STE/ICE	0121 00-1
Test 26 fuel filter pressure drop diagnostic troubleshooting	
STE/ICE	0145 00-1
Test 30 turbocharger outlet pressure	
STE/ICE	0122 00-1
Test 30 turbocharger outlet pressure diagnostic troubleshooting	
STE/ICE	0146 00-1
Test 32 air box pressure	
STE/ICE	0123 00-1
Test 32 air box pressure diagnostic troubleshooting	
STE/ICE	0147 00-1
Test 67 battery voltage	
STE/ICE	0124 00-1
Test 68 starter motor voltage	
STE/ICE	0125 00-1
Test 68 starter motor voltage diagnostic troubleshooting	
STE/ICE	0148 00-1
Test 69 starter negative cable voltage drop	
STE/ICE	0126 00-1
Test 69 starter negative cable voltage drop diagnostic troubleshooting	
STE/ICE	0149 00-1
Test 70 starter solenoid voltage	
STE/ICE	0127 00-1

INDEX, cont'd

<u>Subject</u>	<u>WP Sequence No.-Page No.</u>
Test 70 starter solenoid voltage diagnostic troubleshooting	
STE/ICE	0150 00-1
Test 71 starter current (average)	
STE/ICE	0128 00-1
Test 72 starter current (first peak)	
STE/ICE	0129 00-1
Test 73 battery resistance	
STE/ICE	0130 00-1
Test 74 starter circuit resistance	
STE/ICE	0131 00-1
Test 75 battery resistance change (pack)	
STE/ICE	0130 00-1
Test 80 battery current	
STE/ICE	0132 00-1
Test 82 generator output voltage	
STE/ICE	0133 00-1
Test 82 generator output voltage diagnostic troubleshooting	
STE/ICE	0151 00-1
Test 83 generator field voltage	
STE/ICE	0134 00-1
Test 83 generator field voltage diagnostic troubleshooting	
STE/ICE	0152 00-1
Test 84 generator negative cable voltage drop	
STE/ICE	0135 00-1
Test 84 generator negative cable voltage drop diagnostic troubleshooting	
STE/ICE	0153 00-1
Theory of Operation	0003 00-1
Thermostat	
Replacement	0237 00-1
Thermostatic Fan Speed Switch	
Replacement	0231 00-1
Throttle Valve (TV) Modulator	
Adust	0213 00-1
Tiedown plates	
Rear	
Replacement	0445 00-1
Tool Box Loops	
Replacement	0571 00-1
Torsion bar	
Replacement	0413 00-1
Torsion bar anchor	
Replacement	0414 00-1

INDEX, cont'd

<u>Subject</u>	<u>WP Sequence No.-Page No.</u>
Tow Pintle Extender Assembly	
M113A3	
Repair	0811 02-1
Tow Pintle Extender Kit	
M113A3	
Installation.....	0811 01-1
Tow Start Control Assembly	
Replacement	0391 00-1
Tow Start Control Cable Assembly	
Adjustment	0390 00-1
Tow Start Control Cover	
Replacement	0392 00-1
Towing Pintle	
Repair	0434 00-1
Replacement.....	0433 00-1
Track	
T130	
Replacement.....	0422 00-1
T150	
Replacement.....	0422 01-1
Track Drive Sprocket and Track Assemblies	
Reverse	0419 01-1
Track pad	
Track shoe	0424 01-1,0575 01-1
T150	
Replacement.....	0423 01-1
Track shoe pad	
T150	
Replacement.....	0424 01-1
Track shoe assembly	
Replacement	0423 00-1
Track shoe pad	
Replacement	0424 00-1
Track shoe stowage basket	0575 01-1
Track cover	
Replacement	0438 00-1
Track tension adjuster and mount	
Replacement	0419 00-1
Trailer harness	
Replacement	0375 00-1
Trailer lights don't work	0036 00-1
Trans filter clogged indicator malfunctions.....	0059 00-1
Trans oil hi temp indicator malfunctions	0057 00-1

INDEX, cont'd

<u>Subject</u>	<u>WP Sequence No.-Page No.</u>
Transducer	
Air box pressure	
Replacement.....	0327 00-1
Fuel return pressure	
Replacement.....	0325 00-1
Fuel supply pressure	
Replacement.....	0324 00-1
Turbo outlet pressure	
Replacement.....	0326 00-1
Transmission brake adjustment	
Check	0406 00-1
Transmission brakes	
Adjust	0394 00-1
Transmission controller wiring harness	
Replacement.....	0361 00-1
Transmission does not downshift in 1-4 position.....	0066 00-1
Transmission does not hold 1st position	0067 00-1
Transmission does not hold 2nd position	0068 00-1
Transmission does not hold 3rd position	0069 00-1
Transmission does not pivot steer	0071 00-1
Transmission does not reverse	0070 00-1
Transmission high temp indicator comes on	0072 00-1
Transmission low lube indicator comes on	0073 00-1
Transmission Mounts	
Replacement.....	0385 00-1
Transmission oil	
Cooler hoses, fittings, and mounting	
Replacement.....	0399 00-1
Level dipstick, filler tube, and adapter	
X200-4	
Replacement.....	0395 00-1
X200-4A	
Replacement.....	0396 00-1
Transmission oil and oil filter element	
Replacement.....	0398 00-1
Transmission oil drain tubes and bracket	
Replacement.....	0384 00-1
Transmission oil high temperature switch	
Replacement.....	0322 00-1
Transmission oil low pressure indicator malfunctions	0056 00-1

INDEX, cont'd

<u>Subject</u>	<u>WP Sequence No.-Page No.</u>
Transmission oil sampling valve and pressure switch	
Replacement	0400 00-1
Transmission oil supply and return hoses	
Replacement	0251 00-1
Transmission range controller lamp	
Replacement	0388 00-1
Transmission range controller switch	
Replacement	0389 00-1
Transmission range controller/bracket	
Used with solenoid-activated steering lock	
Replacement	0386 00-1
Transmission steering	
Adjust	0393 00-1
Transmission wiring harness	
Replacement	0360 00-1
Transmission won't upshift or shifts erratically in 1-4 position.....	0065 00-1
Transmitter	
Coolant temperature	
Replacement	0321 00-1
Fuel quantity	
All except M577A3 and M1068A3	
Replacement.....	0190 00-1
M577A3 and M1068A3	
Replacement.....	0191 00-1
Trim Vane	
Replacement	0458 00-1
Trim vane	
All Except M58	
Repair	0459 00-1
M58	
Repair	0460 00-1
Trim vane control linkage	
Repair	0461 00-1
Trim vane release	
Repair	0463 00-1
Replacement	0462 00-1
Tube	
Bulkhead Connection to Personnel Heater	
M577A3 and M1068A3	
Replacement.....	0687 00-1
External Cable	
Replacement	0905 00-1

INDEX, cont'd

<u>Subject</u>	<u>WP Sequence No.-Page No.</u>
Fire Extinguisher Cylinder Discharge	
Replacement.....	0899 00-1
Fire Extinguisher Turbine Cylinder Discharge	
M58	
Replacement.....	0900 00-1
From ramp control valve to bulkhead	
Replacement.....	0664 00-1
Fuel return	
M1064A3	
Replacement.....	0197 00-1
M113A3 , M1059A3, and M58	
Replacement.....	0195 00-1
M577A3 and M1068A3	
Replacement.....	0196 00-1
Fuel Vent	
M577A3 and M1068A3	
Replacement.....	0198 00-1
Personnel heater	
M577A3 and M1068A3	
Replacement.....	0700 00-1
Personnel Heater Fuel	
All Except M1064A3	
Replacement.....	0686 00-1
Thermostat	
Replacement.....	0238 00-1
Turbine access door	
M58	
Replacement.....	0485 00-1
Turbine access door gasket	
M58	
Replacement.....	0486 00-1
Turbine access door hinges	
M58	
Replacement.....	0487 00-1
Turbo outlet pressure transducer	
Replacement.....	0326 00-1
Turnbuckle parts generator	
Replacement.....	0254 00-1
U	
Unsafe ramp	
Lower	0513 00-1
Raise	0513 00-1

INDEX, cont'd

<u>Subject</u>	<u>WP Sequence No.-Page No.</u>
Upper and lower service brake pedal	
Replacement	0409 00-1
Upper Coolant Hose and Tube	
Replacement	0232 00-1
Utility outlet lead assembly	
M577A3 and M1068A3	
Replacement	0377 00-1
Utility outlet receptacle	
Replacement	0265 00-1
Utility outlet receptacles	
Rear	
M577A3 and M1068A3	
Replacement.....	0378 00-1
V	
Valve	
Front Bilge	
Replacement	0633 00-1
Fuel Shutoff	
Coolant Heater	
Replacement.....	0720 00-1
Valve Assembly	
Fuel Shut-off	
M113A3, M1059A3, and M58	
Replacement.....	0684 00-1
Variable speed drive	0359 01-1
Fan	
Replacement (Old Configuration)	0249 00-1
Replacement (New Configuration)	0249 01-1
Controller.....	0250 01-1
Fan Drive and Override Switch	
Replacement (New Configuration)	0231 01-1
Generator	
Replacement (Old Configuration)	0249 00-1
Replacement (New Configuration)	0249 01-1
Variable speed fan drive valve (Old Configuration)	0231 00-1
Override switch (New Configuration).....	0231 01-1
Vehicle batteries discharge with external AC power applied	
M1068A3 only	0103 00-1
Vehicle will not accept external AC power	
M1068A3 only	0104 00-1
Vehicle will not accept inverter AC power	
M1068A3 only	0105 00-1

INDEX, cont'd

<u>Subject</u>	<u>WP Sequence No.-Page No.</u>
Vent fitting	
Battery box	
M58	
Replacement.....	0355 00-1
Ventilating Fan Assembly	
Replacement.....	0247 00-1
Ventilating Fan Drive Belt	
Adjustment.....	0242 00-1
Replacement.....	0243 00-1
Ventilating Fan Drive Pulley	
Replacement.....	0244 00-1
Ventilation fan	
M577A3 and M1068A3	
Replacement.....	0383 00-1
VFM	
Vision Block Locks and Seals	
Driver's Hatch	
Replacement.....	0535 00-1
Vision block locks and seals	
Commander's cupola	
M1064A3	
Replacement.....	0491 00-1
M113A3 and M1059A3, M58	
Replacement.....	0490 00-1
Vision Port	
Ramp	
M58	
Replacement/Repair.....	0586 00-1
Voltage regulator	
Adjustment.....	0256 00-1
W	
W1, W2, and NATO Slave Cables	
Stowage Brackets for	
M1068A3 and M577A3	
Replacement.....	0626 01-1
Wait indicator flashes during start attempts (preglow or afterglow)	0018 00-1
Wait indicator light doesn't light.....	0019 00-1
Warning Light Panel	
All Except M58	
Replacement.....	0292 00-1
Instrument	
Replacement.....	0288 00-1

INDEX, cont'd

<u>Subject</u>	<u>WP Sequence No.-Page No.</u>
Warning light panel Assembly	
All Except M58	
Replacement.....	0291 00-1
Warning Lights	
Instrument Panel	
Replacement.....	0287 00-1
Warning Panel Lights	
M58	
Replacement.....	0294 01-1
Warning panel lights	
All Except M58	
Replacement.....	0294 00-1
Warning panel wiring harness	
Replacement.....	0374 00-1
Water/Ration Heater	
Mount Bracket	
(M113A3 Only)	
Replace.....	0811 00-1
Power Cable	
(M113A3 Only)	
Replace.....	0810 00-1
Webbing straps	
Replacement.....	0569 00-1
Wheel	
Idler	
Replacement.....	0425 00-1
Road	
Replacement.....	0426 00-1
Windshield	
Driver's	
Replacement.....	0739 00-1
Stowage bag, straps, and decal	
Replacement.....	0740 00-1
Stowage Bracket	
M1064A3	
Replacement.....	0614 00-1
Wire harness	
Radiac	
M113A3, M577A3, and M1068A3	
Replacement.....	0376 00-1

INDEX, cont'd

<u>Subject</u>	<u>WP Sequence No.-Page No.</u>
Wire Rope and Pulleys	
M1064A3	
Replacement.....	0658 00-1
Wire rope and pulleys	
All Except M1064A3	
Replacement.....	0657 00-1
Wiring Harness	
Air Box Heater	
Replacement.....	0205 00-1
Coolant Heater	
Replacement.....	0735 00-1
Coolant Pump to Heater	
Replacement.....	0733 00-1
M13 NBC Heater	
(M577A3)	
Replace.....	0808 00-1
M14 NBC Heater	
(M113A3 Ambulance)	
Replace.....	0807 00-1
M3 NBC Heater (M1059A3)	
Replace.....	0806 00-1
Repair	0382 00-1
STE/ICE Crew	
M1064A3	
Replacement.....	0881 00-1
STE/ICE Crew, M113A3 and M1059A3	
Replacement.....	0878 00-1
STE/ICE Crew, M577A3 and M1068A3	
Replacement.....	0879 00-1
STE/ICE Engine	
Replacement.....	0882 00-1
Wiring harness	
3W1	0359 01-1
Battery-to-radio (Left Side)	
M113A3 and M1059A3	
Replacement.....	0369 00-1
Engine	
Replacement.....	0359 00-1
Instrument panel battery-generator gauge	
Replace.....	0289 00-1

INDEX, cont'd

<u>Subject</u>	<u>WP Sequence No.-Page No.</u>
M13 NBC Heater	
M1068A3 only	
Replace.....	0809 00-1
M577A3	
Replace.....	0803 00-1
Rear main	
M1064A3	
Replacement.....	0364 00-1
M1068A3	
Replacement.....	0365 00-1
M113A3, M1059A3, and M58	
Replacement.....	0362 00-1
M577A3	
Replacement.....	0363 00-1
Right headlight	
Replace.....	0373 00-1
Smoke grenade launcher	
M113A3, M1059A3, and M58	
Replacement.....	0366 00-1
Steering lock switch	
All Except M58	
Replacement.....	0367 00-1
M58	
Replacement.....	0367 01-1
Transmission	
Replacement.....	0360 00-1
Transmission controller	
Replacement.....	0361 00-1
Warning panel	
Replacement.....	0374 00-1
Wiring harness (right side)	
Battery-to-radio	
M113A3	
Replacement.....	0370 00-1
Wiring Harnesses, Cables, Leads	
Chemical Alarm Interface	
M113A3	
Replacement.....	0923 00-1
Circuit 44A, Power Control Enclosure Leads	
M1068A3	
Replacement.....	0829 00-1

INDEX, cont'd

Subject

WP Sequence No.-Page No.

Wiring Harnesses, cables, leads

W251

M1068A3

Replacement..... 0852 00-1

W42

M1068A3

Replacement..... 0852 00-1

W43

M1068A3

Replacement..... 0852 00-1

Wiring harnesses, cables, leads

W124

M1068A3

Replacement..... 0855 00-1

Wiring Harnesses, cables, leads:

LAN A or B (W103/W104)

M1068A3

Replacement..... 0854 00-1

W45

M1068A3

Replacement..... 0853 00-1

Wiring harnesses, cables, leads:

W126

M1068A3

Replacement..... 0856 00-1

RECOMMENDED CHANGES TO PUBLICATIONS AND BLANK FORMS	Use Part II (reverse) for Repair Parts and Special Tools Lists (RPSTL) and Supply Catalogs/Supply Manuals (SC/SM).	Date 23 JUL 01
For use of this form, see AR 25-30; the proponent agency is ODISC4.		
TO: (Forward to proponent of publication or form) (Include ZIP Code)		FROM: (Activity and location) (include ZIP code) COMMANDER COMPANY A, 216 CAV FORT KNOX, KY 40121

PART I - ALL PUBLICATIONS (EXCEPT RPSTL AND SC/SM) AND BLANK FORMS

PUBLICATION/FORM NUMBER TM 9-2350-277-20-3	DATE 02 JAN 01	TITLE Unit Maintenance Manual for M113A3 FOV
---	-------------------	---

ITEM	PAGE	PARA	LINE	FIGURE NO.	TABLE	RECOMMENDED CHANGES AND REASON
	0014 00-2					STEP b. THE SCREWS (4) ON BRACKET (2) MUST BE TORQUED PLEASE ADD TORQUE INFORMATION.
	0023 00-34			5 (SH15)		THERE ARE FOUR CLAMPS (144) ON WIRING HARNESS (217), NOT THREE AS SHOWN. PLEASE CORRECT

*Reference to line numbers within the paragraph or subparagraph.

TYPED NAME, GRADE OR TITLE	TELEPHONE EXCHANGE/AUTOVON, PLUS EXTENSION	SIGNATURE

TO: <i>(Forward direct to addressee listed in publication)</i>	FROM: <i>(Activity and location) (Include Zip Code)</i>	DATE
--	---	------

PART II - REPAIR PARTS AND SPECIAL TOOL LISTS AND SUPPLY CATALOGS/SUPPLY MANUALS

PUBLICATION NUMBER			DATE			TITLE		
PAGE NO.	COLM NO.	LINE NO.	NATIONAL STOCK NUMBER	REFERENCE NO.	FIGURE NO.	ITEM NO.	TOTAL NO. OF MAJOR ITEMS SUPPORTED	RECOMMENDED ACTION

PART III - REMARKS *(Any general remarks or recommendations, or suggestions for improvement of publications and blank forms. Additional blank sheets may be used if more space is needed.)*

SAMPLE

TYPED NAME, GRADE OR TITLE	TELEPHONE EXCHANGE/AUTOVON, PLUS EXTENSION	SIGNATURE
----------------------------	--	-----------

TO: <i>(Forward direct to addressee listed in publication)</i>	FROM: <i>(Activity and location) (Include Zip Code)</i>	DATE
--	---	------

PART II - REPAIR PARTS AND SPECIAL TOOL LISTS AND SUPPLY CATALOGS/SUPPLY MANUALS

PUBLICATION NUMBER			DATE			TITLE		
PAGE NO.	COLM NO.	LINE NO.	NATIONAL STOCK NUMBER	REFERENCE NO.	FIGURE NO.	ITEM NO.	TOTAL NO. OF MAJOR ITEMS SUPPORTED	RECOMMENDED ACTION

PART III - REMARKS *(Any general remarks or recommendations, or suggestions for improvement of publications and blank forms. Additional blank sheets may be used if more space is needed.)*

TYPED NAME, GRADE OR TITLE	TELEPHONE EXCHANGE/AUTOVON, PLUS EXTENSION	SIGNATURE
----------------------------	--	-----------

RECOMMENDED CHANGES TO PUBLICATIONS AND BLANK FORMS

For use of this form, see AR 25-30; the proponent agency is ODISC4.

Use Part II (*reverse*) for Repair Parts and Special Tools Lists (RPSTL) and Supply Catalogs/Supply Manuals (SC/SM).

Date

TO: (*Forward to proponent of publication or form*) (*Include ZIP Code*)

FROM: (*Activity and location*) (*include ZIP code*)

PART I - ALL PUBLICATIONS (EXCEPT RPSTL AND SC/SM) AND BLANK FORMS

PUBLICATION/FORM NUMBER
TM 9-2350-277-20-3

DATE
02 JAN 01

TITLE
Unit Maintenance Manual for M113A3 FOV

ITEM	PAGE	PARA	LINE	FIGURE NO.	TABLE	RECOMMENDED CHANGES AND REASON

**Reference to line numbers within the paragraph or subparagraph.*

TYPED, GRADE OR TITLE

TELEPHONE EXCHANGE/AUTOVON, PLUS EXTENSION

SIGNATURE

TO: <i>(Forward direct to addressee listed in publication)</i>	FROM: <i>(Activity and location) (Include Zip Code)</i>	DATE
--	---	------

PART II - REPAIR PARTS AND SPECIAL TOOL LISTS AND SUPPLY CATALOGS/SUPPLY MANUALS

PUBLICATION NUMBER			DATE	TITLE				
PAGE NO.	COLM NO.	LINE NO.	NATIONAL STOCK NUMBER	REFERENCE NO.	FIGURE NO.	ITEM NO.	TOTAL NO. OF MAJOR ITEMS SUPPORTED	RECOMMENDED ACTION

PART III - REMARKS *(Any general remarks or recommendations, or suggestions for improvement of publications and blank forms. Additional blank sheets may be used if more space is needed.)*

TYPED NAME, GRADE OR TITLE	TELEPHONE EXCHANGE/AUTOVON, PLUS EXTENSION	SIGNATURE
----------------------------	--	-----------

RECOMMENDED CHANGES TO PUBLICATIONS AND BLANK FORMS

For use of this form, see AR 25-30; the proponent agency is ODISC4.

Use Part II (*reverse*) for Repair Parts and Special Tools Lists (RPSTL) and Supply Catalogs/Supply Manuals (SC/SM).

Date

TO: (*Forward to proponent of publication or form*) (*Include ZIP Code*)

FROM: (*Activity and location*) (*include ZIP code*)

PART I - ALL PUBLICATIONS (EXCEPT RPSTL AND SC/SM) AND BLANK FORMS

PUBLICATION/FORM NUMBER
TM 9-2350-277-20-3

DATE
02 JAN 01

TITLE
Unit Maintenance Manual for M113A3 FOV

ITEM	PAGE	PARA	LINE	FIGURE NO.	TABLE	RECOMMENDED CHANGES AND REASON

**Reference to line numbers within the paragraph or subparagraph.*

TYPED, GRADE OR TITLE

TELEPHONE EXCHANGE/AUTOVON, PLUS EXTENSION

SIGNATURE

TO: <i>(Forward direct to addressee listed in publication)</i>	FROM: <i>(Activity and location) (Include Zip Code)</i>	DATE
--	---	------

PART II - REPAIR PARTS AND SPECIAL TOOL LISTS AND SUPPLY CATALOGS/SUPPLY MANUALS

PUBLICATION NUMBER			DATE			TITLE		
PAGE NO.	COLM NO.	LINE NO.	NATIONAL STOCK NUMBER	REFERENCE NO.	FIGURE NO.	ITEM NO.	TOTAL NO. OF MAJOR ITEMS SUPPORTED	RECOMMENDED ACTION

PART III - REMARKS *(Any general remarks or recommendations, or suggestions for improvement of publications and blank forms. Additional blank sheets may be used if more space is needed.)*

TYPED NAME, GRADE OR TITLE	TELEPHONE EXCHANGE/AUTOVON, PLUS EXTENSION	SIGNATURE
----------------------------	--	-----------

By Order of the Secretary of the Army:

Official:



JOEL B. HUDSON

*Administrative Assistant to the
Secretary of the Army*

9913209

ERIC K. SHINSEKI
*General, United States Army
Chief of Staff*

DISTRIBUTION: To be distributed in accordance with the initial distribution requirements for IDN: 371205, requirements for TM 9-2350-277-20-3.

THE METRIC SYSTEM AND EQUIVALENTS

LINEAR MEASURE

1 Centimeter = 10 Millimeters = 0.01 Meters = 0.3937 Inches
 1 Meter = 100 Centimeters = 1000 Millimeters = 39.37 Inches
 1 Kilometer = 1000 Meters = 0.621 Miles

WEIGHTS

1 Gram = 0.001 Kilograms = 1000 Milligrams = 0.035 Ounces
 1 Kilogram = 1000 Grams = 2.2 Lb.
 1 Metric Ton = 1000 Kilograms = 1 Megagram = 1.1 Short Tons

LIQUID MEASURE

1 Milliliter = 0.001 Liters = 0.0338 Fluid Ounces
 1 Liter = 1000 Milliliters = 33.82 Fluid Ounces

SQUARE MEASURE

1 Sq. Centimeter = 100 Sq. Millimeters = 0.155 Sq. Inches
 1 Sq. Meter = 10,000 Sq. Centimeters = 10.76 Sq. Feet
 1 Sq. Kilometer = 1,000 Sq. Meters = 0.386 Sq. Miles

CUBIC MEASURE

1 Cu. Centimeter = 1000 Cu. Millimeters = 0.06 Cu. Inches
 1 Cu. Meter = 1,000,000 Cu. Centimeters = 35.31 Cu. Feet

TEMPERATURE

$5/9 (^{\circ}\text{F} - 32) = ^{\circ}\text{C}$
 212° Fahrenheit is equivalent to 100° Celsius
 90° Fahrenheit is equivalent to 32.2° Celsius
 32° Fahrenheit is equivalent to 0° Celsius
 $(9/5 \times ^{\circ}\text{C}) + 32 = ^{\circ}\text{F}$

TO CHANGE	TO	MULTIPLY BY
Inches	Centimeters	2.540
Feet	Meters	0.305
Yards	Meters	0.914
Miles	Kilometers	1.609
Square Inches	Square Centimeters	6.451
Square Feet	Square Meters	0.093
Square Yards	Square Meters	0.836
Square Miles	Square Kilometers	2.590
Acres	Square Hectometers	0.405
Cubic Feet	Cubic Meters	0.028
Cubic Yards	Cubic Meters	0.765
Fluid Ounces	Millimeters	29.573
Pints	Liters	0.473
Quarts	Liters	0.946
Gallons	Liters	3.785
Ounces	Grams	28.349
Pounds	Kilograms	0.454
Short Tons	Metric Tons	0.907
Pound-Feet	Newton-Meters	1.356
Pounds per Square Inch	Kilopascals	6.895
Miles per Gallon	Kilometers per Liter	0.425
Miles per Hour	Kilometers per Hour	1.609

TO CHANGE	TO	MULTIPLY BY
Centimeters	Inches	0.394
Meters	Feet	3.280
Meters	Yards	1.094
Kilometers	Miles	0.621
Square Centimeters	Square Inches	0.155
Square Meters	Square Feet	10.764
Square Meters	Square Yards	1.196
Square Kilometers	Square Miles	0.386
Square Hectometers	Acres	2.471
Cubic Meters	Cubic Feet	35.315
Cubic Meters	Cubic Yards	1.308
Milliliters	Fluid Ounces	0.034
Liters	Pints	2.113
Liters	Quarts	1.057
Liters	Gallons	0.264
Grams	Ounces	0.035
Kilograms	Pounds	2.205
Metric Tons	Short Tons	1.102
Newton-Meters	Pound-Feet	0.738
Kilopascals	Pounds per Square Inch	0.145
Kilometers per Liter	Miles per Gallon	2.354
Kilometers per Hour	Miles per Hour	0.621

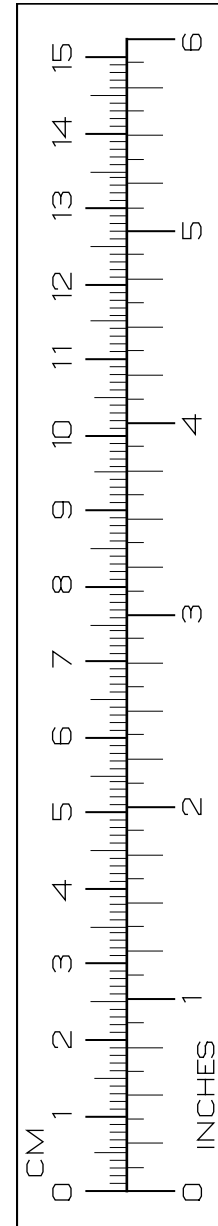

PIN: 072978-000